

NordicTrack[®] **CX 1055**

Patent Pending

Model No. NEL90952

Serial No. _____

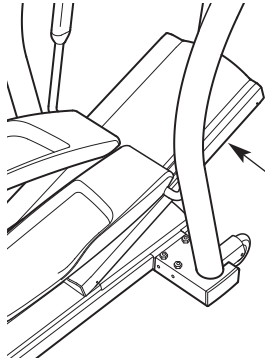

Serial Number
Decal
(beneath
ramp)

USER'S MANUAL

QUESTIONS?

If you have questions, or if there are missing parts, we will guarantee complete satisfaction through direct assistance from our factory.

TO AVOID DELAYS, PLEASE CALL DIRECT TO OUR TOLL-FREE CUSTOMER HOT LINE. The trained technicians on our customer hot line will provide immediate assistance, free of charge to you.

CUSTOMER HOT LINE:

1-888-825-2588

Mon.-Fri., 6 a.m.-6 p.m. MST

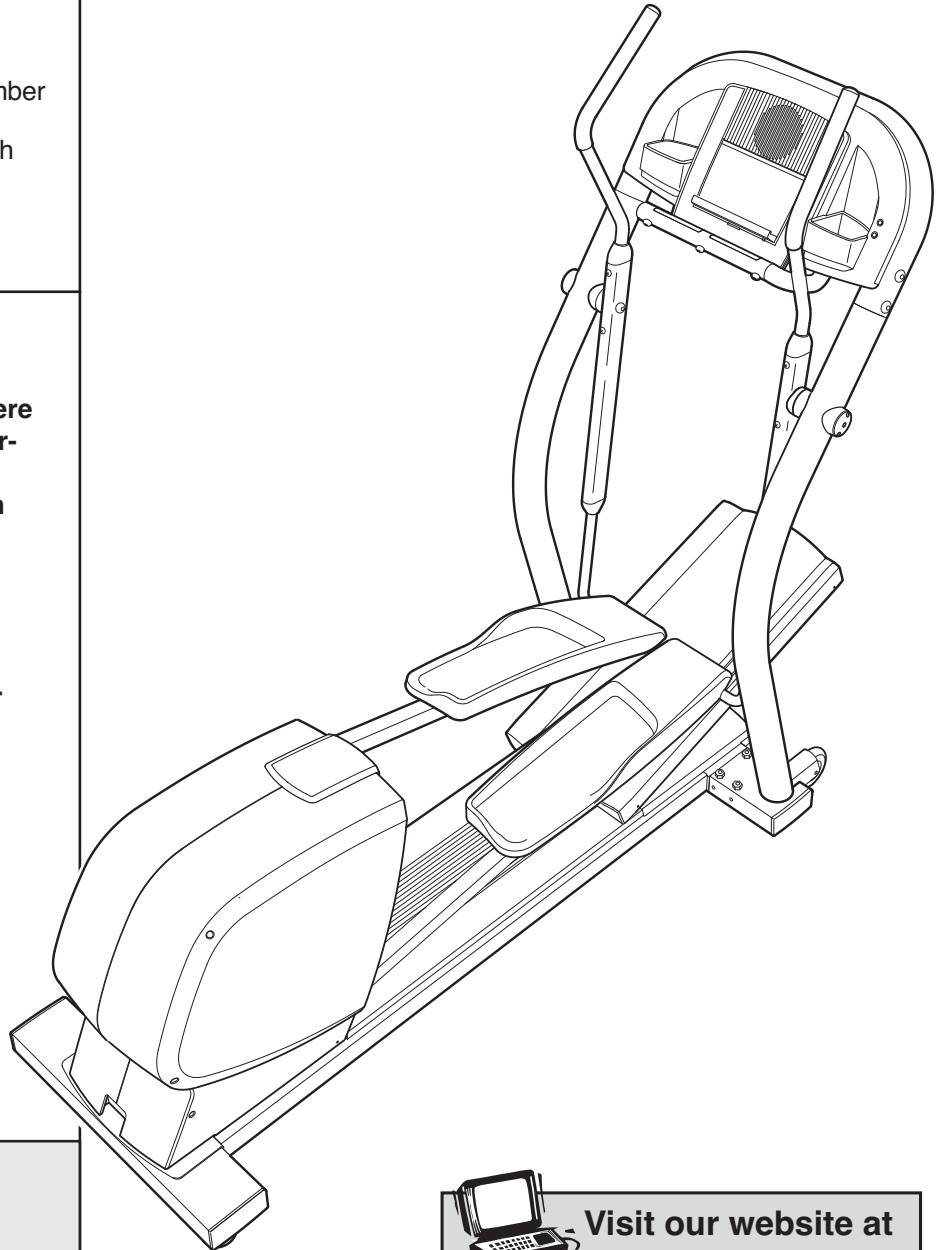

⚠ CAUTION

Read all precautions and instructions in this manual before using this equipment. Keep this manual for future reference.



Visit our website at

www.nordictrack.com

new products, prizes,
fitness tips, and much more!



NordicTrack®

CX 1055

TABLE OF CONTENTS

IMPORTANT PRECAUTIONS	3
BEFORE YOU BEGIN	4
ASSEMBLY	5
HOW TO USE THE ELLIPTICAL EXERCISER	9
MAINTENANCE AND TROUBLESHOOTING	21
CONDITIONING GUIDELINES	22
PART LIST	25
EXPLODED DRAWING	26
HOW TO ORDER REPLACEMENT PARTS	Back Cover
LIMITED WARRANTY	Back Cover

IMPORTANT PRECAUTIONS

⚠ WARNING: To reduce the risk of serious injury, read the following important precautions before using the elliptical exerciser.

1. Read all instructions in this manual before using the elliptical exerciser.
2. It is the responsibility of the owner to ensure that all users of the elliptical exerciser are adequately informed of all precautions.
3. The elliptical exerciser is intended for in-home use only. Do not use the elliptical exerciser in a commercial, rental, or institutional setting.
4. Place the elliptical exerciser on a level surface, with a mat beneath it to protect the floor or carpet. Keep the elliptical exerciser indoors, away from moisture and dust.
5. Inspect and properly tighten all parts regularly. Replace any worn parts immediately.
6. Keep children under age 12 and pets away from the elliptical exerciser at all times.
7. The elliptical exerciser should not be used by persons weighing more than 300 pounds.
8. Wear appropriate exercise clothes when using the elliptical exerciser. Always wear athletic shoes for foot protection.
9. Always hold the handlebars when mounting, dismounting, or using the elliptical exerciser.
10. Keep your back straight when using the elliptical exerciser; do not arch your back.
11. If you feel pain or dizziness while exercising, stop immediately and begin cooling down.
12. The pulse sensor is not a medical device. Various factors, including the user's movement, may affect the accuracy of heart rate readings. The pulse sensor is intended only as an exercise aid in determining heart rate trends in general.
13. When you stop exercising, allow the pedals to slowly come to a complete stop. The elliptical exerciser does not have a free wheel; the pedals will continue to move until the flywheel stops.
14. Always unplug the power cord immediately after use and before cleaning the elliptical exerciser.
15. The decals shown on page 4 have been placed on the elliptical exerciser. If either decal is missing or illegible, please call our Customer Service Department toll-free at 1-888-825-2588 and order a free replacement decal. Apply the decal in the location shown.

⚠ WARNING: Before beginning this or any exercise program, consult your physician. This is especially important for persons over the age of 35 or persons with pre-existing health problems. Read all instructions before using. ICON assumes no responsibility for personal injury or property damage sustained by or through the use of this product.

BEFORE YOU BEGIN

Congratulations for selecting the new NordicTrack® CX 1055 elliptical exerciser. The CX 1055 elliptical exerciser is an incredibly smooth exerciser that moves your feet in a natural elliptical path, minimizing the impact on your knees and ankles. And the unique CX 1055 elliptical exerciser features adjustable resistance and incline to help you get the most from your exercise.



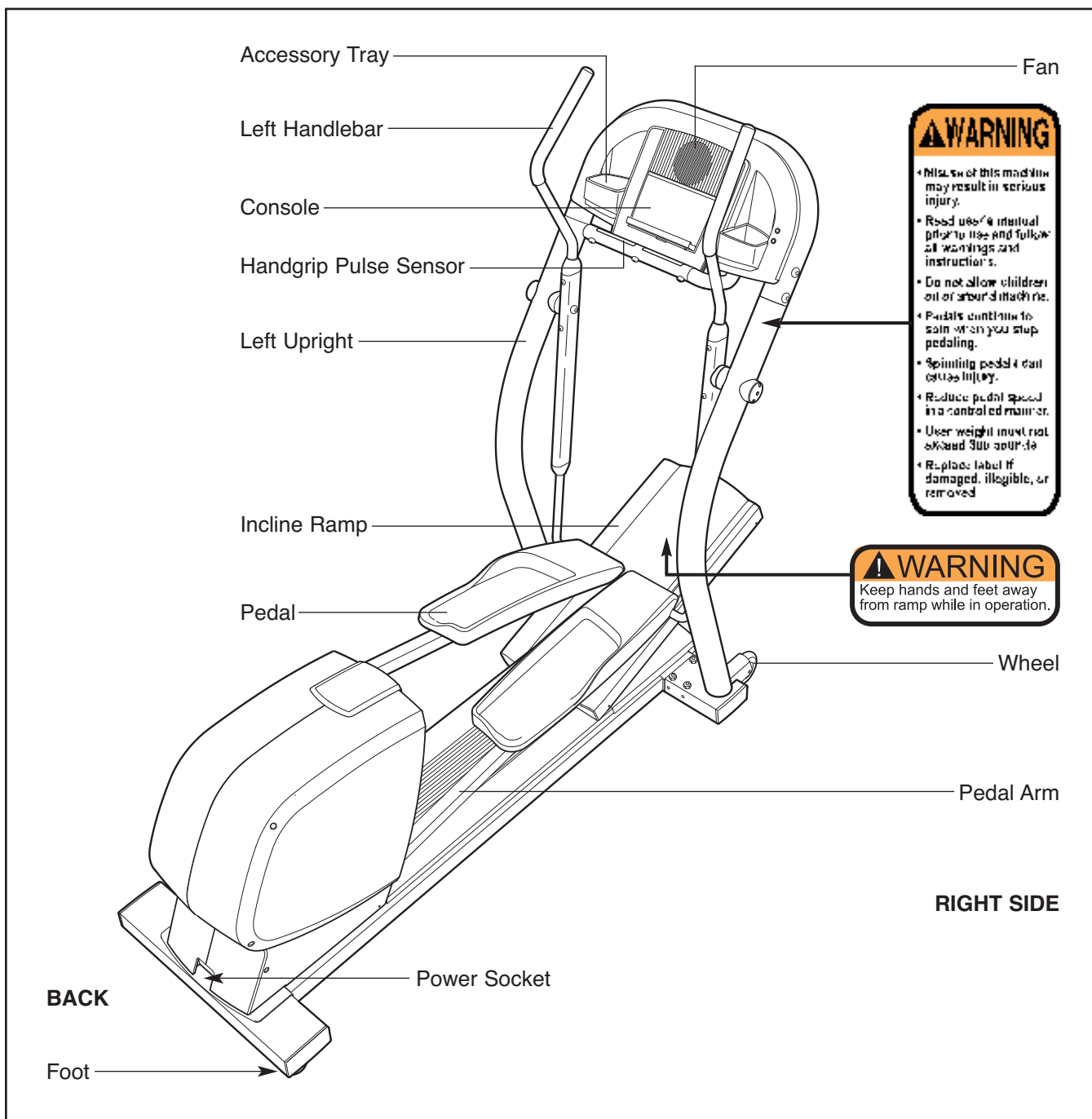

For your benefit, read this manual carefully before you use the elliptical exerciser. If you have questions after reading the manual, please call our

Customer Service Department toll-free at 1-888-825-2588, Monday through Friday, 6 a.m. until 6 p.m. Mountain Time (excluding holidays). To help us assist you, please note the product model number and serial number before calling. The model number is NEL90952. The serial number can be found on a decal attached to the elliptical exerciser (see the front cover of this manual for the location of the decal).

Before reading further, please familiarize yourself with the parts that are labeled in the drawing below.

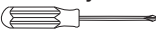

ASSEMBLY

Assembly requires two persons. Place all parts of the elliptical exerciser in a cleared area and remove the packing materials. Do not dispose of the packing materials until assembly is completed. **In addition to the two included hex keys, assembly requires a phillips screwdriver** , **two adjustable wrenches** , **a rubber mallet** , and **pliers** .

Use the drawings below to identify the small parts used for assembly. The number in parenthesis below each drawing is the key number of the part, from the PART LIST on page 25. The number following the key number is the quantity needed for assembly. **Note: Some small parts may have been pre-assembled. If a part is not in the parts bag, check to see if it has been pre-assembled.**

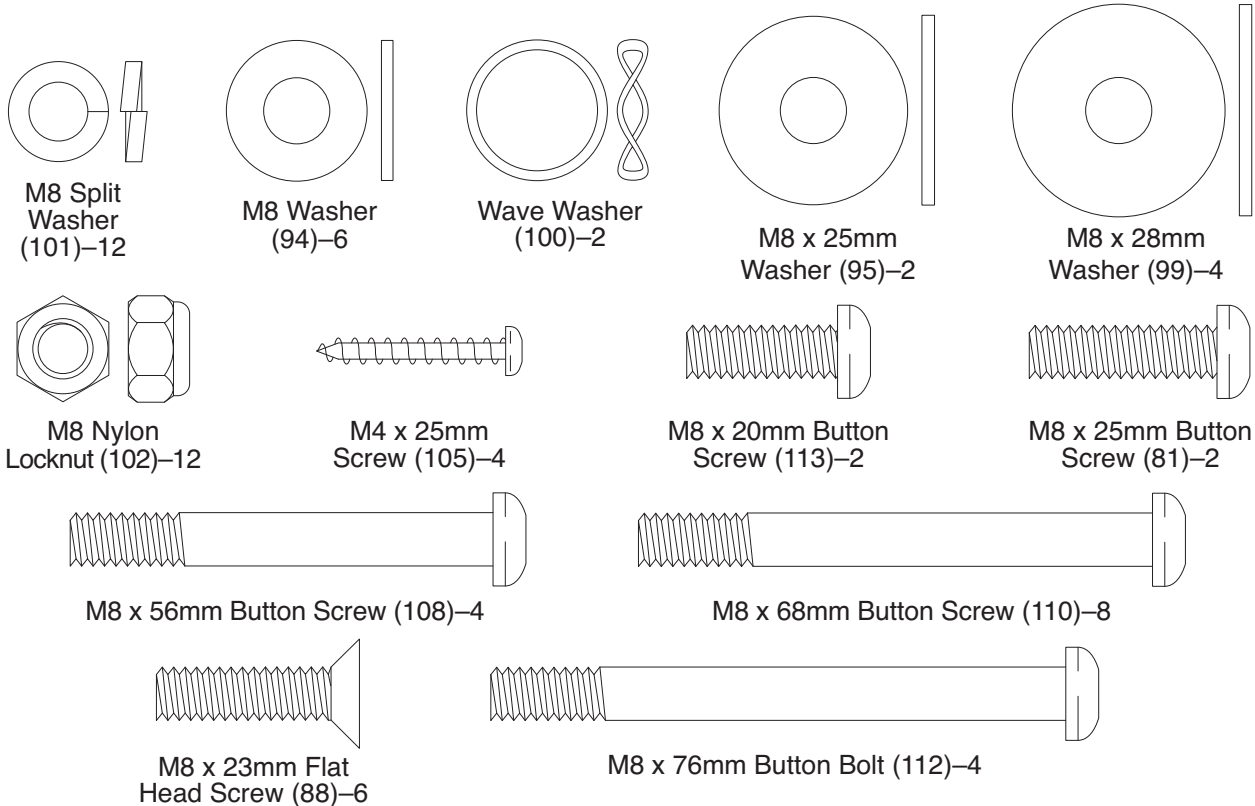

1. Remove the Pivot Arms (not shown) and the plastic inserts from the Left and Right Uprights (4, 3). Identify the Left Upright (4) and hold it near the Frame (1). While another person lifts the left side of the elliptical exerciser, connect the Extension Wire Harness (76) to the Lower Wire Harness (77).

Insert the Left Upright (4) into the Frame (1), and attach it with two M8 x 56mm Button Screws (108), two M8 x 68mm Button Screws (110), and four M8 Split Washers (101); **make sure not to pinch the Wire Harnesses (76, 77)**. Tighten a Frame Cushion (32) into the Frame (1) as indicated.

While another person lifts the right side of the Frame (1), attach the Right Upright (3) to the Frame in the same way. (Note: There are no wire harnesses on the right side.) Tighten the other Frame Cushion (32) into the other side of the Frame (1).

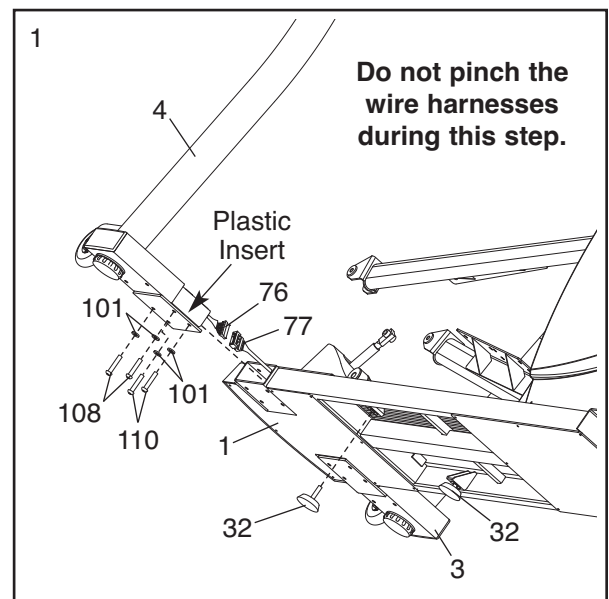

- Hold the Console Frame (6) near the Uprights (3, 4). Connect the Upper Wire Harness (75) to the Extension Wire Harness (76). Attach the Console Frame to the Uprights with four M8 x 76mm Button Bolts (112) and four M8 Nylon Locknuts (102); **make sure not to pinch the Wire Harnesses.**

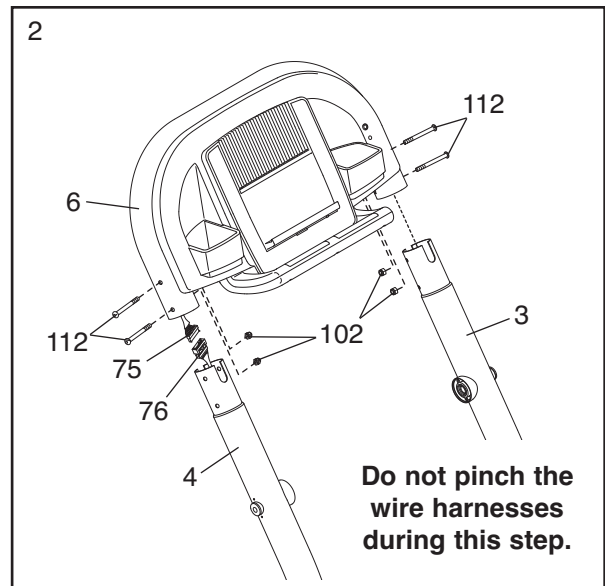

- Slide an M8 x 28mm Washer (99) onto an M8 x 20mm Button Screw (113). Tighten the Button Screw into one end of the Incline Axle (40). Apply a small amount of the included grease to the Incline Axle.

Orient the Incline Ramp (5) so that the straight end is in the position shown. Hold the welded tube on the bottom of the Incline Ramp between the two rings on the top of the Frame. Insert the Incline Axle (40) through the rings and the welded tube.

Slide an M8 x 28mm Washer (99) onto an M8 x 20mm Button Screw (113). Tighten the Button Screw into the open end of the Incline Axle (40).

Be careful not to scratch the Incline Ramp (5) during steps 4 through 6.

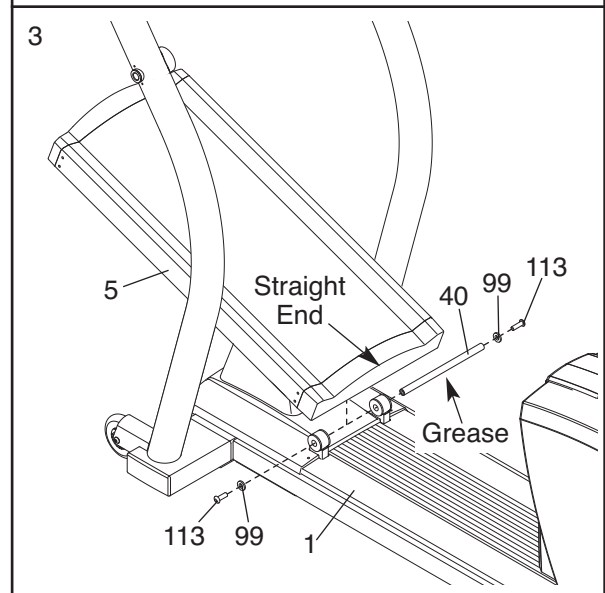

- Using your fingers, turn the shaft on top of the Lift Motor (42) counterclockwise until it stops turning. Position the U-bracket on the bottom of the Incline Ramp (5) over the end of the shaft as shown. Next, hold an Incline Motor Spacer (60) on each side of the shaft, between the shaft and the U-bracket.

Next, insert the Short Clevis Pin (118) through the U-bracket on the Incline Ramp (5), the shaft on the Lift Motor (42), and the two Incline Motor Spacers (60). Insert the straight end of a Hairpin (71) into the end of the Short Clevis Pin.

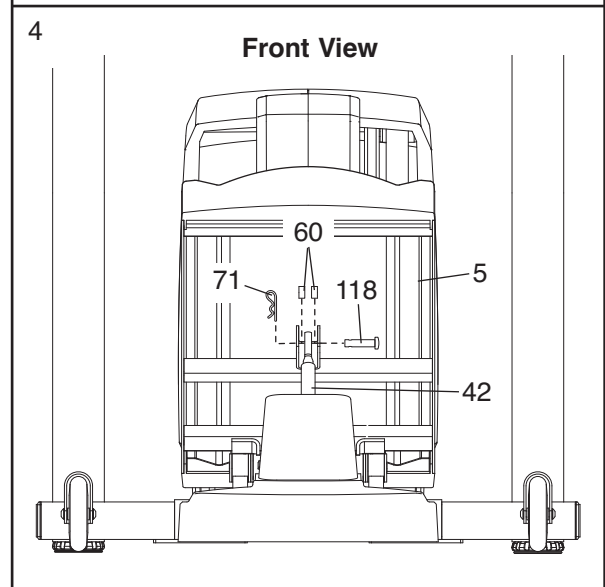

5. See the inset drawing. While another person tips the elliptical exerciser as shown, place a sturdy piece of packaging foam beneath the elliptical exerciser.

Orient the Rear Stabilizer (2) so that the holes are closer to the front. While another person steadies the elliptical exerciser, attach the Rear Stabilizer to the back of the Frame (1) with four M8 x 68mm Button Screws (110) and four M8 Split Washers (101).

Carefully remove the piece of packaging foam and tip the elliptical exerciser back down.

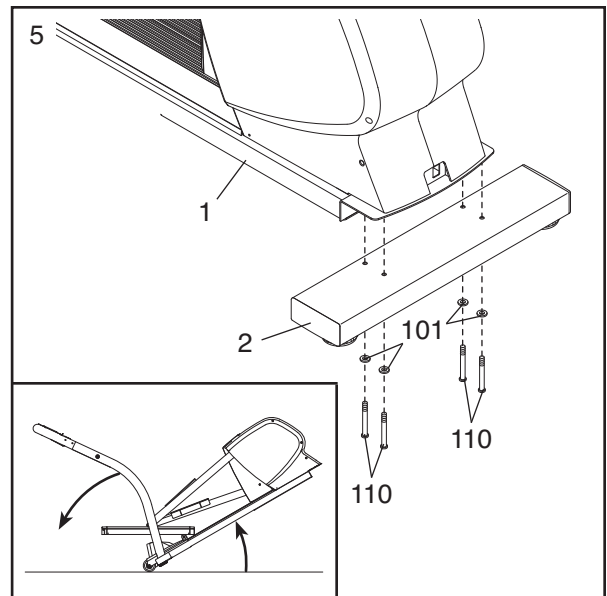

6. Apply a small amount of grease to the axle on each Pivot Shaft (15).

Hold a Pedal Wheel (35) inside of the bracket on the end of the Right Pedal Arm (11). Next, insert a Pivot Shaft (15) through the holes in the end of the Right Pedal Arm and the Pedal Wheel as indicated. Tighten an M8 Nylon Locknut (102) with an M8 x 25mm Washer (95) onto the end of the Pivot Shaft.

Attach the other Pivot Shaft (15) and the other Pedal Wheel (35) to the Left Pedal Arm (12) in the same way.

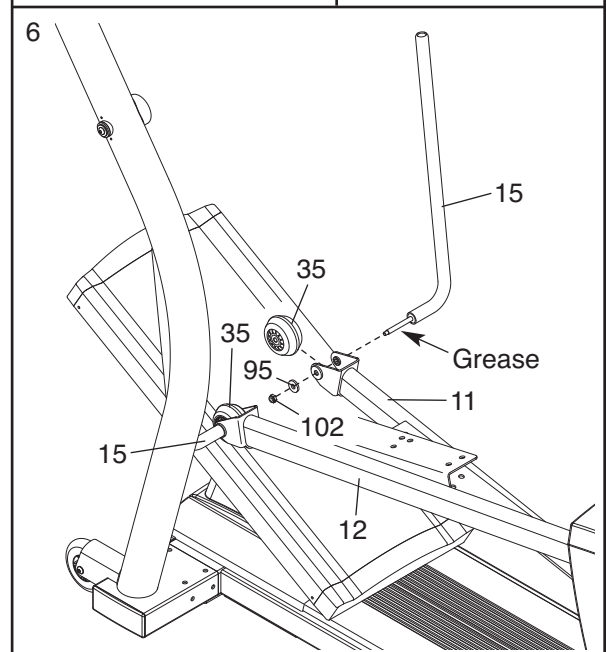

7. Identify the Left Pedal (14). Attach the Left Pedal to the Left Pedal Arm (12) with three M8 x 23mm Flat Head Screws (88), three M8 Washers (94), and three M8 Nylon Locknuts (102). Then, press the Left Pedal Insert (121) onto the Left Pedal.

Attach the Right Pedal (13) to the Right Pedal Arm (not shown), and press the Right Pedal Insert (122) into the Right Pedal, in the same way.

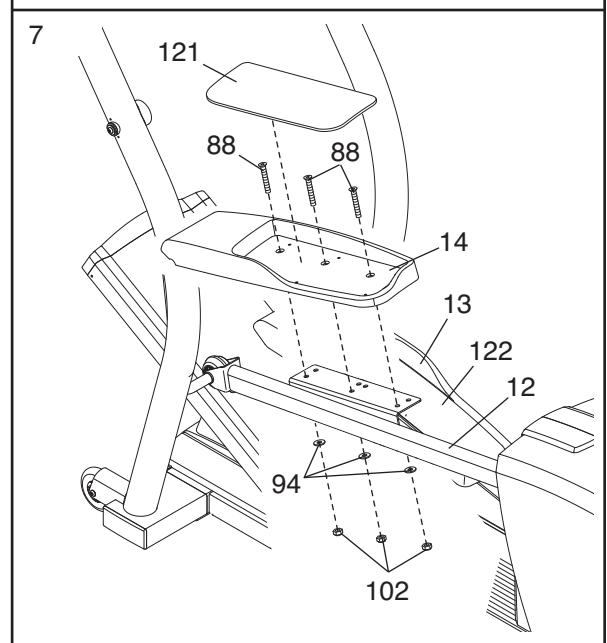

8. Apply a thin film of the included Teflon® lubricant to both Pivot Shafts (15).

Identify the Right Handlebar (9), which is marked with a sticker. Apply a small amount of grease to the axle on the Right Handlebar, to the Pivot Arm Cover (64), and to the Inner Upright Cover (63). Next, slide the Right Handlebar onto the right Pivot Shaft (15), and insert the axle on the Right Handlebar into the Right Upright (3). **Note: Position the Right Pedal (13) near the top of the Incline Ramp (5), and then lift and push the Pedal toward the center of the Incline Ramp while inserting the axle into the Upright.**

Place a Wave Washer (100) on the end of the axle on the Right Handlebar (9). Next, apply a small amount of grease to an M8 x 28mm Washer (99), and slide the Washer onto an M8 x 25mm Button Screw (81). Tighten the Button Screw into the axle.

Attach an Outer Upright Cover (74) to the Right Upright (3) with two M4 x 25mm Screws (105).

Attach the Left Handlebar (10) to the left Pivot Shaft (15) and the Left Upright (4) in the same way.

9. Plug the Power Cord (8) into the Power Receptical (68) at the rear of the elliptical exerciser.

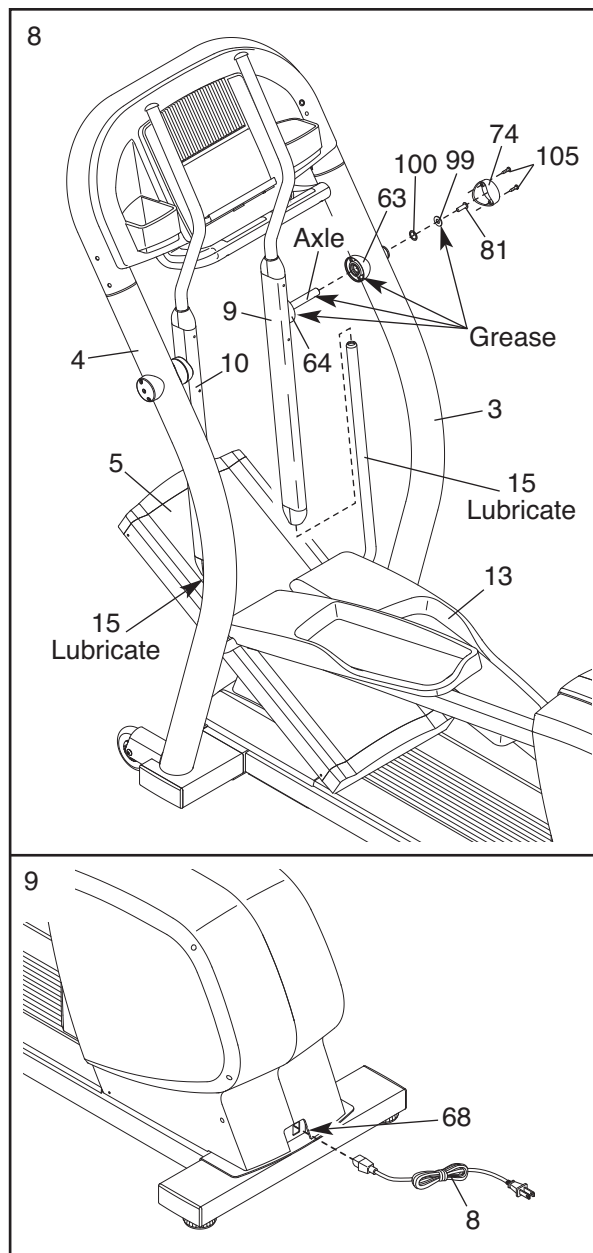

10. **Make sure that all parts of the elliptical exerciser are properly tightened.** Cover the floor beneath the elliptical exerciser to protect the floor from damage. Note: Some extra hardware may be left over.

HOW TO USE THE ELLIPTICAL EXERCISER

HOW TO PLUG IN THE POWER CORD

This product must be grounded. If it should malfunction or break down, grounding provides a path of least resistance for electric

current to reduce the risk of electric shock. This product is equipped with a cord having an equipment-grounding conductor and a grounding plug. **Plug the power cord into an appropriate outlet that is properly installed and grounded in accordance with all local codes and ordinances. This product is for use on a nominal 120-volt circuit. Important: The elliptical exerciser is not compatible with GFCI-equipped outlets.**

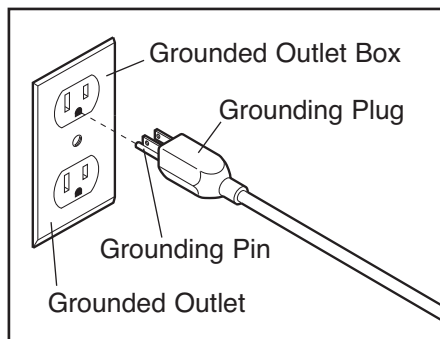

⚠ DANGER: Improper connection of the equipment-grounding conductor can result in an increased risk of electric shock. Check with a qualified electrician or serviceman if you are in doubt as to whether the product is properly grounded. Do not modify the plug provided with the product—if it will not fit the outlet, have a proper outlet installed by a qualified electrician.

A temporary adapter may be used to connect the power cord to a 2-pole receptacle as shown at the right if a properly grounded outlet is not

available. The temporary adapter should be used only until a properly grounded outlet can be installed by a qualified electrician.

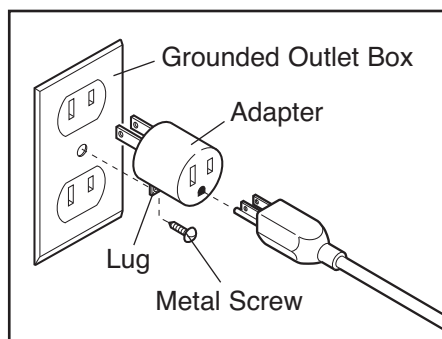

The green-colored rigid ear, lug, or the like extending from the adapter must be connected to a permanent ground such as a properly grounded outlet box cover. Whenever the adapter is used, it must be held in place by a metal screw. **Some 2-pole receptacle outlet box covers are not grounded. Contact a qualified electrician to determine if the outlet box cover is grounded before using an adapter.**

Note: When the power cord is plugged in, the elliptical exerciser's incline system may automatically calibrate itself. During the calibration process, three dashes (---) will appear in the console display, and the incline ramp will rise to the highest position and then sink to the lowest position. The calibration process will last for one to two minutes. If the incline system does not calibrate itself, see **HOW TO CALIBRATE THE INCLINE SYSTEM** on page 21.

EXERCISING ON THE ELLIPTICAL EXERCISER

To mount the elliptical exerciser, hold the handlebars and step onto the pedal that is in the lowest position. Next, step onto the other pedal. Push the pedals until they begin to move with a continuous motion.

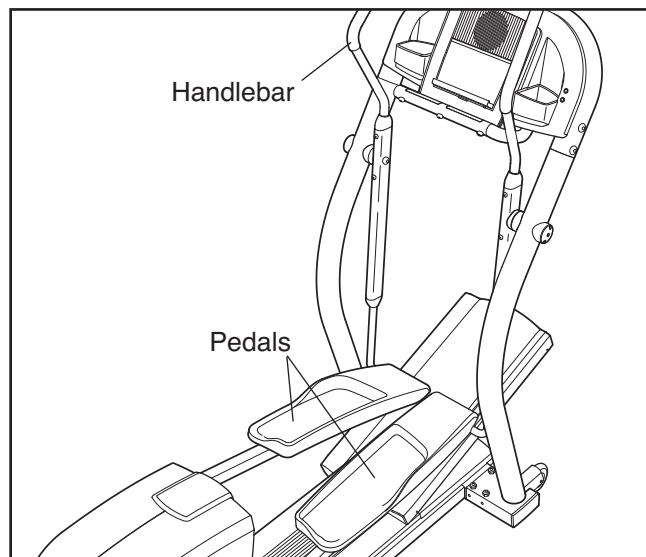

To dismantle the elliptical exerciser, wait until the pedals come to a complete stop. **The elliptical exerciser does not have a free wheel; the pedals will continue to move until the flywheel stops.** When the pedals are stationary, step off the highest pedal first. Then, step off the lowest pedal.

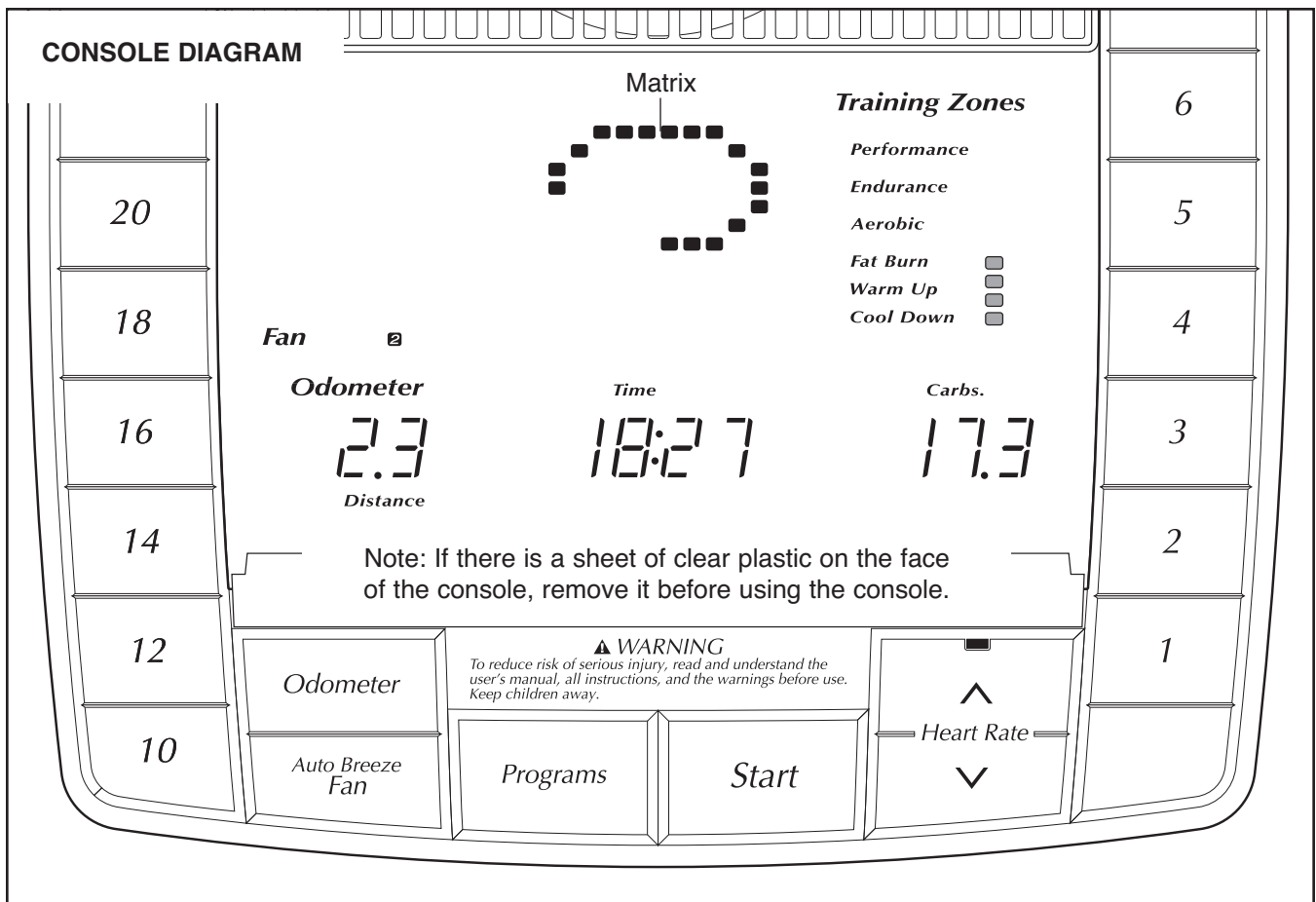

FEATURES OF THE CONSOLE

The advanced console offers a selection of features designed to make your workouts more enjoyable and effective. When the manual mode of the console is selected, the resistance of the elliptical exerciser and the angle of the ramp can be changed with the touch of a button. As you exercise, the console will provide continuous exercise feedback. You can even measure your heart rate using the handgrip pulse sensor.

The console also offers fifteen preset programs. Each program automatically changes the resistance of the elliptical exerciser and prompts you to increase or decrease your pace as it guides you through an effective workout.

In addition, the console features four heart rate programs that automatically change the resistance of the elliptical exerciser and prompt you to vary your pace to keep your heart rate near a target level as you exercise.

The console also features iFIT.com interactive technology. Having iFIT.com technology is like having a per-

sonal trainer in your home. Using a stereo audio cable, you can connect the elliptical exerciser to your portable stereo, home stereo, computer, or VCR and play special iFIT.com MP3, CD, and video programs (iFIT.com MP3 programs, CDs, and videocassettes are available separately). iFIT.com programs automatically control the resistance of the elliptical exerciser and prompt you to vary your pace as a personal trainer coaches you through every step of your workout. High-energy music provides added motivation. **To purchase and download iFIT.com MP3 programs, go to www.iFIT.com. To purchase iFIT.com CDs and videocassettes, call toll-free 1-888-825-2588.**

With the elliptical exerciser connected to your computer, you can also go to our Web site at www.iFIT.com and access programs directly from the internet. **Explore www.iFIT.com for more information.**

To use the manual mode of the console, follow the steps beginning on page 11. **To use a preset program**, see page 13. **To use a heart rate program**, see page 14. **To use an iFIT.com MP3, CD, or video program**, see page 19. **To use an iFIT.com program directly from our Web site**, see page 20.

HOW TO USE THE MANUAL MODE

1 Press any button on the console or begin pedaling to turn on the console.

Make sure that the power cord is properly plugged in (see page 9). Next, press any button on the console or begin pedaling to turn on the console. After a few seconds, the console displays will light. A tone will then sound and the console will be ready for use.

2 Select the manual mode.

When the power is turned on, the manual mode will be selected. If you have selected a program or the iFIT.com mode, reselect the manual mode by pressing the Programs button repeatedly until a track appears in the matrix. Make sure that the letters "iFIT" do not appear in the center of the display.

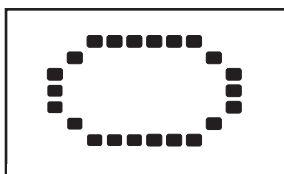

3 Begin pedaling and change the resistance of the elliptical exerciser as desired.

As you pedal, change the resistance of the elliptical exerciser by pressing the 1 Step Resistance buttons.

Note: After the 1 Step Resistance buttons are pressed, it will take a moment for the elliptical exerciser to reach the selected resistance level.



4 Adjust the angle of the ramp as desired.

As you pedal, change the angle of the ramp by pressing the 1 Step Ramp buttons. Note: After the 1 Step Ramp buttons are pressed, it will take a moment for the ramp to reach the selected angle.

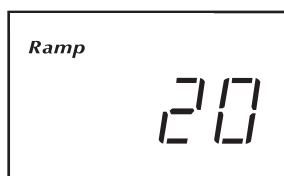

5 Monitor your progress with the matrix, the Training Zones bar, and the displays.

The matrix—When the manual mode or the iFIT.com mode is selected, the matrix will show a

track representing 1/4 mile. As you exercise, the indicators around the track will light in succession until the entire track is lit. The track will then darken and the indicators will again begin to light in succession.

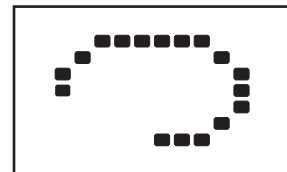

The Training Zones bar

—The Training Zones bar will show the approximate intensity level of your exercise. If four indicators in the bar are lit, for example, the bar shows that your pace is ideal for fat burning.

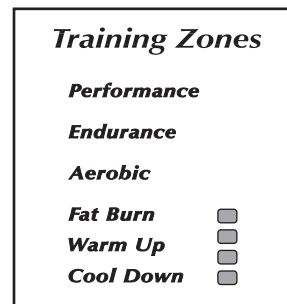

The Odometer display—The Odometer display will show the distance that you have pedaled during your workout.

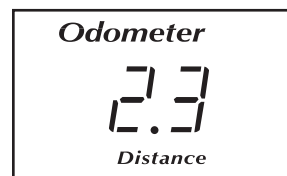

To see the total distance pedaled since the elliptical exerciser was purchased, press the Odometer button; the words "Total Miles" and the total number of miles will appear in the display.

To see the total distance pedaled during a recent time period, such as the most recent month, press the Odometer button again; the words "My Miles" and the total number of miles will appear in the display. To reset this number, hold down the Odometer button for a few seconds.

To again see the distance that you have pedaled during your workout, press the Odometer button again.

The center display

—The center display will show the elapsed time, the resistance level of the elliptical exerciser, your pedaling speed, your pedaling pace, in revolutions per minute (RPM), and the angle of the ramp. The display will change from one number to the next every few seconds. Note: When a program is selected, the display will show the time remaining in the program instead of the elapsed time.



The right display—

The right display will show the approximate number of grams of carbs you have burned and the approximate number of calories you have burned. The display will change from one number to the next every few seconds. The display will also show your heart rate when you use the handgrip pulse sensor.

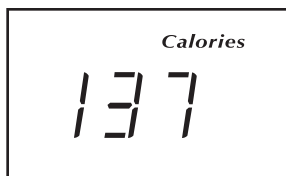

6 Measure your heart rate if desired.

If there are thin sheets of plastic on the metal contacts on the handgrip pulse sensor, peel off the plastic. To measure your heart rate,

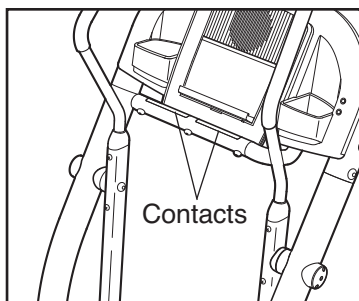

hold the contacts; your palms must be resting against the contacts. **Avoid moving your hands or gripping the contacts too tightly.**

When your pulse is detected, one or two dashes (—) will appear in the right display, and then your heart rate will be shown. For the most accurate heart rate reading, hold the contacts for at least 15 seconds.

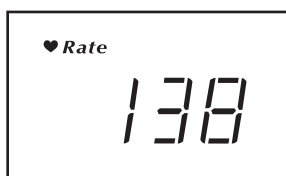

Note: If you continue to hold the pulse sensor, the right display will show your heart rate for up to 30 seconds. The display will then show your heart rate along with the other modes.

If your heart rate is not shown, make sure that your hands are positioned as described. Be careful not to move your hands excessively or to squeeze the metal contacts too tightly. For optimal performance, clean the metal contacts using a soft cloth; never use alcohol, abrasives, or chemicals.

7 Turn on the fan if desired.

To turn on the fan at low speed, press the Auto Breeze Fan button; the number 1 will appear next to the word "Fan" in the display. To turn on the fan at medium speed, press the button a second time; the number 2 will appear. To turn on the fan at high speed, press the button a third time; the number 3 will appear. To select the Auto mode, press the button again; the word "Auto" will appear. When the auto mode is selected, the speed of the fan will automatically increase and decrease as you increase and decrease your pedaling speed.

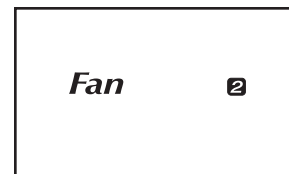

To turn off the fan, press the Auto Breeze Fan button again. Note: If the pedals are not turned for a few minutes, the fan will automatically turn off.

8 When you are finished exercising, the console will automatically turn off.

If the pedals are not moved for several seconds, a tone will sound, the console will pause, and the time will begin to flash in the center display.

If the pedals are not moved for about five minutes, the console will turn off and the displays will be reset.

HOW TO USE A PRESET PROGRAM

1 Press any button on the console or begin pedaling to turn on the console.

See step 1 on page 11.

2 Select one of the fifteen preset programs.

To select one of the fifteen preset programs, press the Programs button repeatedly until the words “Weight Loss,” “Aerobic,” or “Performance” and the number 1, 2, 3, 4, or 5 appear in the center of the display.



When a preset program is selected, a profile of the resistance settings of the program will scroll across the matrix. The center display will show how long the program will last.

3 Press the Start button or begin pedaling to start the program.

Each program is divided into several one-minute segments. One resistance setting and one pace setting are programmed for each segment. Note: The same resistance setting and/or pace setting may be programmed for two or more consecutive segments.

The resistance setting for the first segment will be shown in the flashing Current Segment column of the matrix. (The pace settings are not shown in the matrix.) The resistance settings for the next several segments will be shown in the columns to the right.

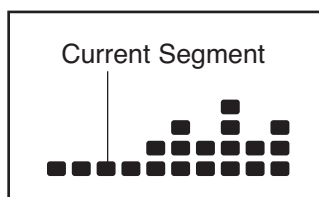

As you exercise, the Target Pace guide will help you to keep your pedaling pace near the pace setting for the current segment. When the words “Too Slow” appear in the display, increase your

pace. When the words “Too Fast” appear, decrease your pace. When the words “On Pace” appear, your pace matches the pace setting for the current segment.

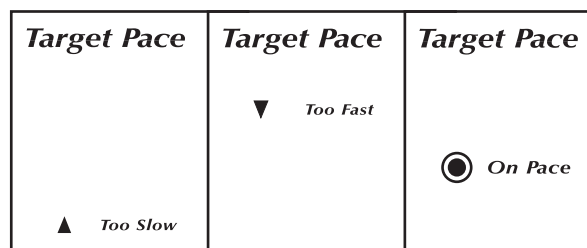

Important: The pace settings are intended only to provide motivation. Your actual pace may be slower than the pace settings. Make sure to exercise at a pace that is comfortable for you.

When only three seconds remain in the first segment of the program, both the Current Segment column and the column to the right will flash, a series of tones will sound, and *all resistance settings will move one column to the left*. The resistance setting for the second segment will then be shown in the flashing Current Segment column, and the resistance of the elliptical exerciser will change to the resistance setting for the second segment. Note: If all of the indicators in the Current Segment column are lit after the resistance settings have moved to the left, *the resistance settings may move downward* so only the highest indicators appear in the matrix.

The program will continue until the resistance setting for the last segment is shown in the Current Segment column and the last segment ends.

Note: During the program, you can override the resistance setting for the current segment, if desired, by pressing the 1 Step Resistance buttons. However, when the next segment begins, the resistance will change if a different resistance setting is programmed for the next segment.

If you stop pedaling for several seconds, a tone will sound and the program will pause. To restart the program, simply resume pedaling.

4 Adjust the angle of the ramp as desired.

See step 4 on page 11.

5 Monitor your progress with the displays.

See step 5 on page 11.

6 Measure your heart rate if desired.

See step 6 on page 12.

7 Turn on the fan if desired.

See step 7 on page 12.

8 When the program is finished, the console will automatically turn off.

See step 8 on page 12.

HOW TO USE A HEART RATE PROGRAM

Each heart rate program helps you to keep your heart rate near a target heart rate setting during your workout.

Follow the steps below to use a heart rate program.

1 Press any button on the console or begin pedaling to turn on the console.

See step 1 on page 11.

2 Select one of the four heart rate programs.

To select a heart rate program, press the Programs button repeatedly until the words “Heart Rate” and the number 1, 2, 3, or 4 appear in the center of the display.

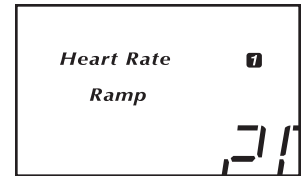

As each heart rate program is selected, a profile of the target heart rate settings of the selected program will scroll across the matrix. The center display will show how long the program will last.

3 Enter a maximum target heart rate setting.

When a heart rate program is selected, the heart symbol and the word “RATE” will appear in the right display and the maximum target heart rate setting will flash. If desired, press the Heart Rate buttons to change the maximum target heart rate setting.

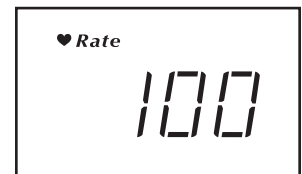

4 Hold the handgrip pulse sensor.

To use a heart rate program, you must use the handgrip pulse sensor (see step 6 on page 12). It is not necessary to hold the handgrips continuously during the program. However, you should hold the handgrips frequently for the program to operate properly. **Each time you hold the handgrips, keep your hands on the metal contacts for at least 30 seconds.**

5 Press the Start button to start the program.

Each heart rate program is divided into one-minute segments. One target heart rate setting is programmed for each segment. Note: The same target heart rate setting may be programmed for two or more consecutive segments.

The target heart rate setting for the first segment will be shown in the flashing Current Segment column of the matrix. The target heart rate settings for the next seven segments will be shown in the columns to the right.

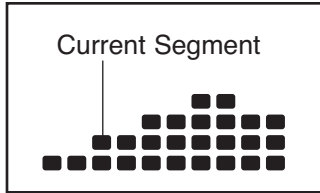

When only three seconds remain in the first segment of the program, both the Current Segment column and the column to the right will flash, a series of tones will sound, and *all target heart rate settings will move one column to the left*. The target heart rate setting for the second segment will then be shown in the flashing Current Segment column.

As you pedal, the console will regularly compare your heart rate to the target heart rate setting. If your heart rate is too far below or above the target heart rate setting, the resistance of the elliptical exerciser will automatically increase or decrease to bring your heart rate closer to the target heart rate setting.

The Target Pace guide will prompt you to increase or decrease your pedaling pace during the program. When the words “Too Slow” appear in the display, increase your pace. When the words “Too Fast” appear, decrease your pace. When the words “On Pace” appear, maintain your current pace.

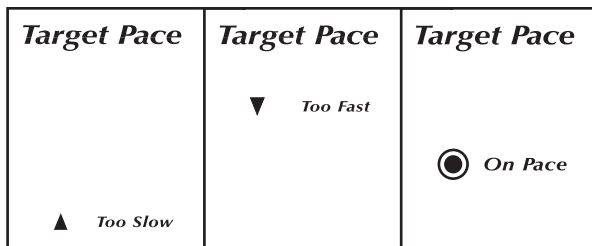

Important: The target heart rate settings are intended only to provide motivation. Your actual heart rate may be slower than the target heart rate settings. Make sure to exercise at a pace that is comfortable for you.

The program will continue until the target heart rate setting for the last segment is shown in the Current Segment column of the matrix and the last segment ends.

Note: During the program, you can manually override the resistance setting for the current segment, if desired, with the 1 Step Resistance buttons. However, when the console compares your heart rate to the target heart rate setting, the resistance of the elliptical exerciser may automatically increase or decrease to bring your heart rate closer to the target heart rate setting.

If you stop pedaling for several seconds, a tone will sound and the program will pause. To restart the program, simply resume pedaling.

6 Adjust the angle of the ramp as desired.

See step 4 on page 11.

7 Monitor your progress with the displays.

See step 5 on page 11.

8 Turn on the fan if desired.

See step 7 on page 12.

9 When the program is finished, the console will automatically turn off.

See step 8 on page 12.

HOW TO CONNECT THE ELLIPTICAL EXERCISER TO USE IFIT.COM PROGRAMS

To use iFIT.com MP3 or CD programs, the elliptical exerciser must be connected to your MP3 player, CD player, portable stereo, home stereo, or computer. See pages 16 and 17 for connecting instructions. To use iFIT.com programs directly from our Web site, the elliptical exerciser must be connected to your computer. See page 17 for connecting instructions. To use iFIT.com video programs, the elliptical exerciser must be connected to your VCR. See page 18 for connecting instructions.

HOW TO CONNECT YOUR MP3 PLAYER OR CD PLAYER

- A. Plug one end of the included 1/8" to 1/8" stereo audio cable into either jack on the console. Plug the other end of the cable into a jack on your MP3 player or CD player. Plug your headphones into the other jack on the console.

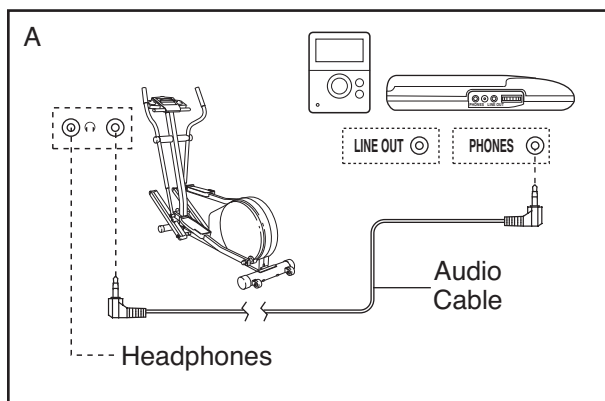

HOW TO CONNECT YOUR PORTABLE STEREO

Note: If your stereo has an RCA-type AUDIO OUT jack, see instruction A below. If your stereo has a 1/8" LINE OUT jack, see instruction B. If your stereo has only a PHONES jack, see instruction C.

- A. Plug one end of a long 1/8" to RCA stereo audio cable (available at electronics stores) into either jack on the console. Plug the other end of the cable into the AUDIO OUT jack on your stereo.

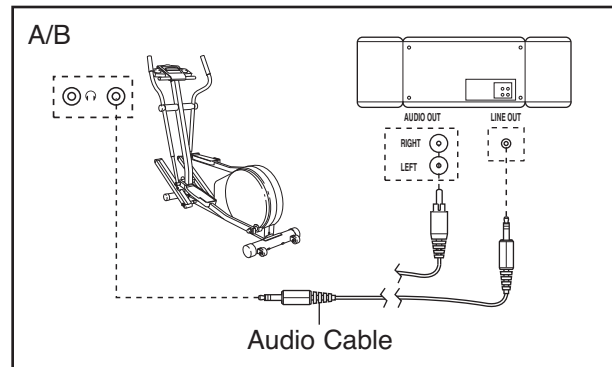

- B. See the drawing above. Plug one end of a long 1/8" to 1/8" stereo audio cable (available at electronics stores) into either jack on the console. Plug the other end of the cable into the LINE OUT jack on your stereo. Note: While the cable is plugged into the LINE OUT jack, do not plug your headphones into the other jack on the console.

- C. Plug one end of a long 1/8" to 1/8" stereo audio cable (available at electronics stores) into either jack on the console. Plug the other end of the cable into the PHONES jack on your stereo. Plug your headphones into the other jack on the console.

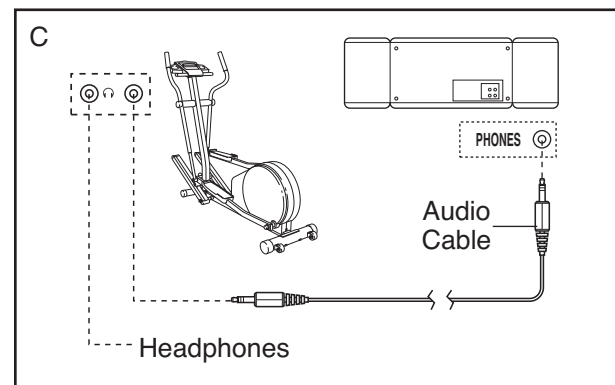

HOW TO CONNECT YOUR HOME STEREO

Note: If your stereo has an unused LINE OUT jack, see instruction A below. If the LINE OUT jack is being used, see instruction B.

- A. Plug one end of a long 1/8" to RCA stereo audio cable (available at electronics stores) into either jack on the console. Plug the other end of the cable into the LINE OUT jack on your stereo. Note: While the cable is plugged into the LINE OUT jack, do not plug your headphones into the other jack on the console.

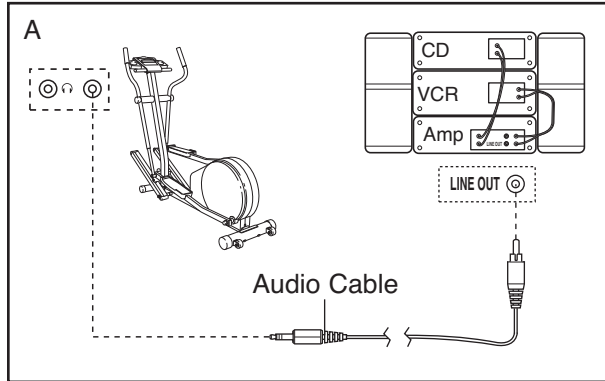

- B. Plug one end of a long 1/8" to RCA stereo audio cable (available at electronics stores) into either jack on the console. Plug the other end of the cable into an RCA Y-adapter (available at electronics stores). Next, remove the wire that is currently plugged into the LINE OUT jack on your stereo and plug the wire into the unused side of the Y-adapter. Plug the Y-adapter into the LINE OUT jack on your stereo. Note: While the Y-adapter is plugged into the LINE OUT jack, do not plug your headphones into the other jack on the console.

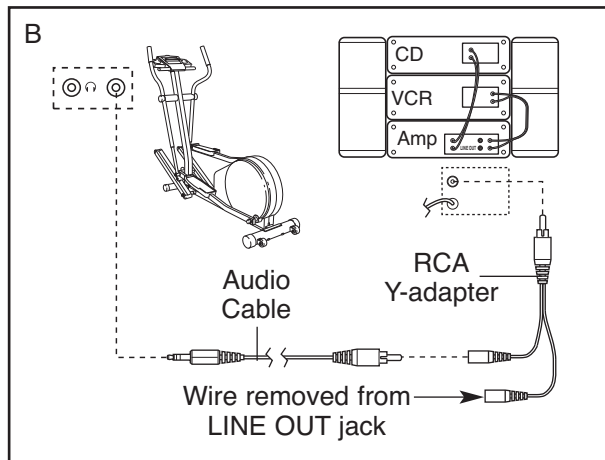

HOW TO CONNECT YOUR COMPUTER

- A. Plug one end of a long 1/8" to 1/8" stereo audio cable (available at electronics stores) into either jack on the console. Plug the other end of the cable into the LINE OUT jack on your computer. Note: While the cable is plugged into the LINE OUT jack, do not plug your headphones into the other jack on the console.

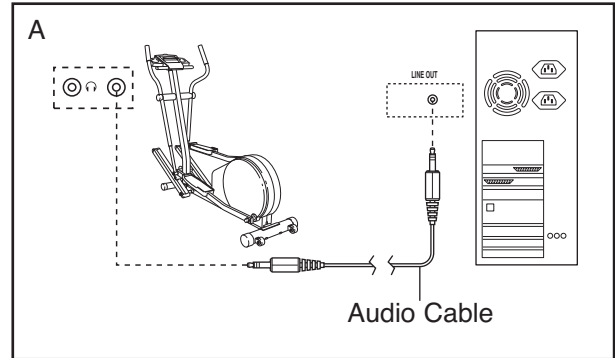

HOW TO CONNECT YOUR VCR

Note: If your VCR has an unused AUDIO OUT jack, see instruction A below. If the AUDIO OUT jack is being used, see instruction B. If you have a TV with a built-in VCR, see instruction B. If your VCR is connected to your home stereo, see HOW TO CONNECT YOUR HOME STEREO on page 17.

- A. Plug one end of a long 1/8" to RCA stereo audio cable (available at electronics stores) into either jack on the console. Plug the other end of the cable into the AUDIO OUT jack on your VCR.

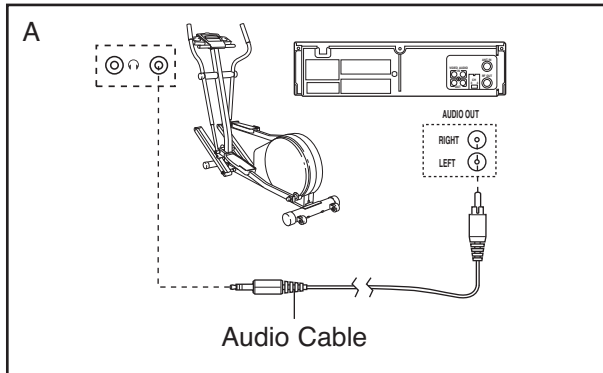

- B. Plug one end of a long 1/8" to RCA stereo audio cable (available at electronics stores) into either jack on the console. Plug the other end of the cable into an RCA Y-adapter (available at electronics stores). Next, remove the wire that is currently plugged into the AUDIO OUT jack on your VCR and plug the wire into the unused side of the Y-adapter. Plug the Y-adapter into the AUDIO OUT jack on your VCR.

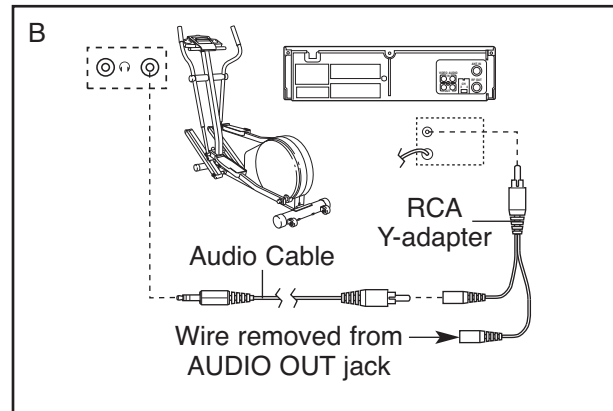

HOW TO USE AN iFIT.COM MP3, CD, OR VIDEO PROGRAM

To use an iFIT.com MP3, CD, or video program, the elliptical exerciser must be connected to your MP3 player, CD player, or VCR. See HOW TO CONNECT THE ELLIPTICAL EXERCISER TO USE iFIT.COM PROGRAMS on pages 16 to 18. **To purchase and download iFIT.com MP3 programs, go to www.iFIT.com. To purchase iFIT.com CDs or videocassettes, call toll-free 1-888-825-2588.**

Follow the steps below to use an iFIT.com MP3, CD, or video program.

Follow the steps below to use an iFIT.com CD or video program.

1 Press any button on the console or begin pedaling to turn on the console.

See step 1 on page 11.

2 Select the iFIT.com mode.

To select the iFIT.com mode, press the Programs button repeatedly until the track and the letters “iFIT” light in the center of the display.

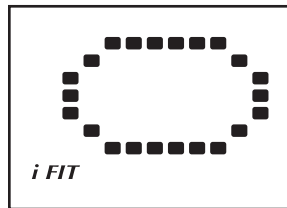

3 Press the Play button on your MP3 player, CD player, or VCR.

Note: If you are using an iFIT.com CD, insert the CD into your CD player; if you are using an iFIT.com videocassette, insert the videocassette into your VCR.

A moment after the play button is pressed, your personal trainer will begin guiding you through your workout. Simply follow your personal trainer’s instructions.

The program will function in almost the same way as a preset program (see step 3 on page 13). However, an electronic “chirping” sound will alert you when the resistance setting and/or pace setting is about to change.

Note: If the resistance of the elliptical exerciser and/or the pace setting does not change when a “chirp” is heard:

- Make sure that the letters “iFIT” appear in the center of the display.
- Adjust the volume of your MP3 player, CD player, or VCR. If the volume is too high or too low, the console may not detect the program signals.
- Make sure that the audio cable is properly connected and that it is fully plugged in.

4 Adjust the angle of the ramp as desired.

See step 4 on page 11.

5 Monitor your progress with the displays.

See step 5 on page 11.

6 Measure your heart rate as desired.

See step 6 on page 12.

7 Turn on the fan if desired.

See step 7 on page 12.

8 When the program is finished, the console will automatically turn off.

See step 8 on page 12.

HOW TO USE PROGRAMS DIRECTLY FROM OUR WEB SITE

Our Web site at www.iFIT.com allows you to play iFIT.com programs directly from the internet. To use programs from our Web site, the elliptical exerciser must be connected to your home computer. See **HOW TO CONNECT YOUR COMPUTER** on page 17. In addition, you must have an internet connection and an internet service provider. A list of specific system requirements is found on our Web site.

Follow the steps below to use a program from our Web site.

1 Press any button on the console or begin pedaling to turn on the console.

See step 1 on page 11.

2 Select the iFIT.com mode.

To select the iFIT.com mode, press the Programs button repeatedly until the track and the letters “iFIT” light in the center of the display.

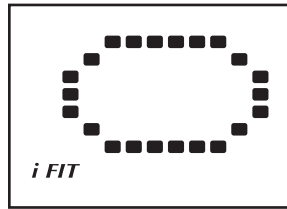

3 Go to your computer and start an internet connection.

4 Start your Web browser, if necessary, and go to our Web site at www.iFIT.com.

5 Follow the desired links on our Web site to select a program.

Read and follow the on-line instructions for using a program.

6 Follow the on-line instructions to start the program.

When you start the program, an on-screen count-down will begin.

7 Return to the elliptical exerciser and begin pedaling.

When the on-screen countdown ends, the program will begin. The program will function in almost the same way as a preset program (see step 3 on page 13). However, an electronic “chirping” sound will alert you when the resistance setting and/or pace setting is about to change.

8 Adjust the angle of the ramp if desired.

See step 4 on page 11.

9 Monitor your progress with the displays.

See step 5 on page 11.

10 Measure your heart rate if desired.

See step 6 on page 12.

11 Turn on the fan if desired.

See step 7 on page 12.

12 When the program is finished, the console will automatically turn off.

See step 8 on page 12.

MAINTENANCE AND TROUBLESHOOTING

Inspect and properly tighten all parts of the elliptical exerciser regularly. Replace any worn parts immediately.

For smooth operation of the elliptical exerciser, **inspect and clean the incline ramp regularly** using a soft cloth and mild detergent. Other parts of the elliptical exerciser can also be cleaned in this way. **Keep liquids off the console. Never use abrasives or solvents.**

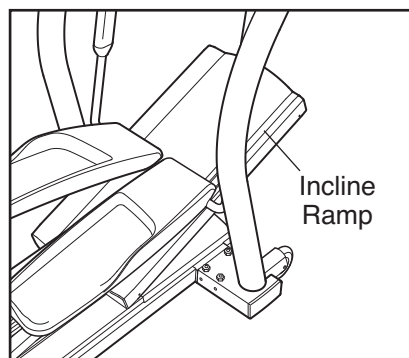

PULSE SENSOR TROUBLESHOOTING

If the handgrip pulse sensor does not function properly, see step 6 on page 12.

HOW TO CALIBRATE THE INCLINE SYSTEM

If the elliptical exerciser's incline system is not working properly, activate the calibration process by following the steps below.

1. Hold down the Start button and the Heart Rate increase button at the same time for about five seconds. Note: Numbers may appear in the display; disregard these numbers.
2. Press the Start button again. Note: A combination of letters and numbers will appear in the display.
3. Press the 30° 1 Step Ramp button. The incline ramp will rise to the highest position and then sink to the lowest position.
4. Press the Start button three times. The console will then be in the normal operating mode and the elliptical exerciser will be ready for use.

HOW TO MOVE THE ELLIPTICAL EXERCISER

Stand in front of the elliptical exerciser, hold the frame firmly, and place one foot against the incline ramp in the location shown below. Pull the frame until the elliptical exerciser can be moved on the front wheels, and carefully move the elliptical exerciser to the desired location. Then, place one foot against the incline ramp, and lower the elliptical exerciser. **Due to the size and weight of the elliptical exerciser, use extreme caution while moving and lowering it.**

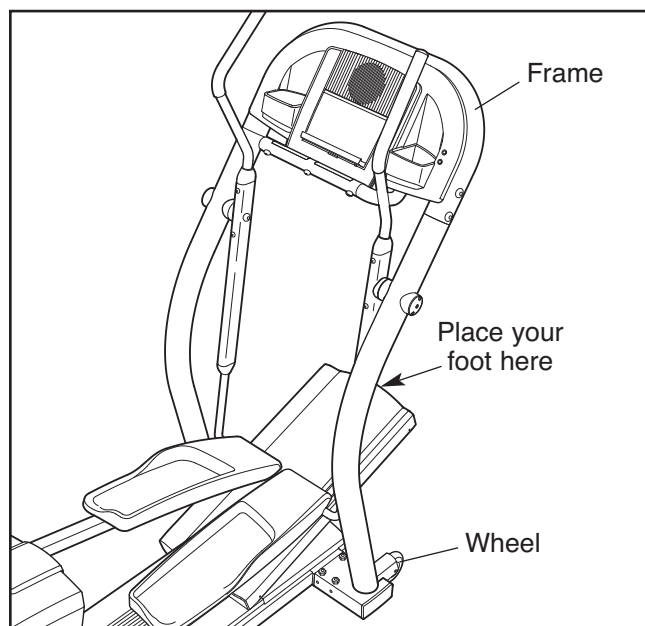

HOW TO LEVEL THE ELLIPTICAL EXERCISER

If the elliptical exerciser rocks during use, turn one or both of the leveling feet under the rear stabilizer until the rocking motion is eliminated.

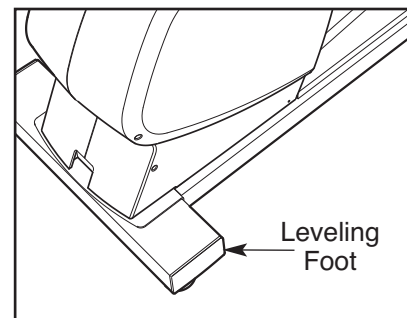

CONDITIONING GUIDELINES

WARNING:



Before beginning this or any exercise program, consult your physician. This is especially important for persons over the age of 35 or persons with pre-existing health problems.

The pulse sensor is not a medical device. Various factors, including the user's movement, may affect the accuracy of heart rate readings. The pulse sensor is intended only as an exercise aid in determining heart rate trends in general.

The following guidelines will help you to plan your exercise program. Remember that proper nutrition and adequate rest are essential for successful results.

EXERCISE INTENSITY

Whether your goal is to burn fat or to strengthen your cardiovascular system, the key to achieving the desired results is to exercise with the proper intensity. The proper intensity level can be found by using your heart rate as a guide. The chart below shows recommended heart rates for fat burning, maximum fat burning, and cardiovascular (aerobic) exercise.

165	155	145	140	130	125	115	
145	138	130	125	118	110	103	
125	120	115	110	105	95	90	
20	30	40	50	60	70	80	

To find the proper heart rate for you, first find your age near the bottom of the chart (ages are rounded off to the nearest ten years). Next, find the three numbers above your age. The three numbers are your “training zone.” The lower two numbers are recommended heart rates for fat burning; the highest number is the recommended heart rate for aerobic exercise.

Fat Burning

To burn fat effectively, you must exercise at a relatively low intensity level for a sustained period of time.

During the first few minutes of exercise, your body uses easily accessible *carbohydrate* calories for energy. Only after the first few minutes of exercise does your body begin to use stored *fat* calories for energy. If your goal is to burn fat, adjust the intensity of your exercise until your heart rate is near the lowest number in your training zone as you exercise.

For maximum fat burning, adjust the intensity of your exercise until your heart rate is near the middle number in your training zone as you exercise.

Aerobic Exercise

If your goal is to strengthen your cardiovascular system, your exercise must be “aerobic.” Aerobic exercise is activity that requires large amounts of oxygen for prolonged periods of time. This increases the demand on the heart to pump blood to the muscles, and on the lungs to oxygenate the blood. For aerobic exercise, adjust the intensity of your exercise until your heart rate is near the highest number in your training zone as you exercise.

WORKOUT GUIDELINES

Each workout should include the following three parts:

A warm-up, consisting of 5 to 10 minutes of stretching and light exercise. A proper warm-up increases your body temperature, heart rate, and circulation in preparation for exercise.

Training zone exercise, consisting of 20 to 30 minutes of exercising with your heart rate in your training zone. (During the first few weeks of your exercise program, do not keep your heart rate in your training zone for longer than 20 minutes.)

A cool-down, with 5 to 10 minutes of stretching. This will increase the flexibility of your muscles and will help to prevent post-exercise problems.

EXERCISE FREQUENCY

To maintain or improve your condition, complete three workouts each week, with at least one day of rest between workouts. After a few months of regular exercise, you may complete up to five workouts each week if desired. The key to success is to make exercise a regular and enjoyable part of your everyday life.

SUGGESTED STRETCHES

The correct form for several basic stretches is shown at the right. Move slowly as you stretch—never bounce.

1. Toe Touch Stretch

Stand with your knees bent slightly and slowly bend forward from your hips. Allow your back and shoulders to relax as you reach down toward your toes as far as possible. Hold for 15 counts, then relax. Repeat 3 times. Stretches: Hamstrings, back of knees and back.

2. Hamstring Stretch

Sit with one leg extended. Bring the sole of the opposite foot toward you and rest it against the inner thigh of your extended leg. Reach toward your toes as far as possible. Hold for 15 counts, then relax. Repeat 3 times for each leg. Stretches: Hamstrings, lower back and groin.

3. Calf/Achilles Stretch

With one leg in front of the other, reach forward and place your hands against a wall. Keep your back leg straight and your back foot flat on the floor. Bend your front leg, lean forward and move your hips toward the wall. Hold for 15 counts, then relax. Repeat 3 times for each leg. To cause further stretching of the achilles tendons, bend your back leg as well. Stretches: Calves, achilles tendons and ankles.

4. Quadriceps Stretch

With one hand against a wall for balance, reach back and grasp one foot with your other hand. Bring your heel as close to your buttocks as possible. Hold for 15 counts, then relax. Repeat 3 times for each leg. Stretches: Quadriceps and hip muscles.

5. Inner Thigh Stretch

Sit with the soles of your feet together and your knees outward. Pull your feet toward your groin area as far as possible. Hold for 15 counts, then relax. Repeat 3 times. Stretches: Quadriceps and hip muscles.

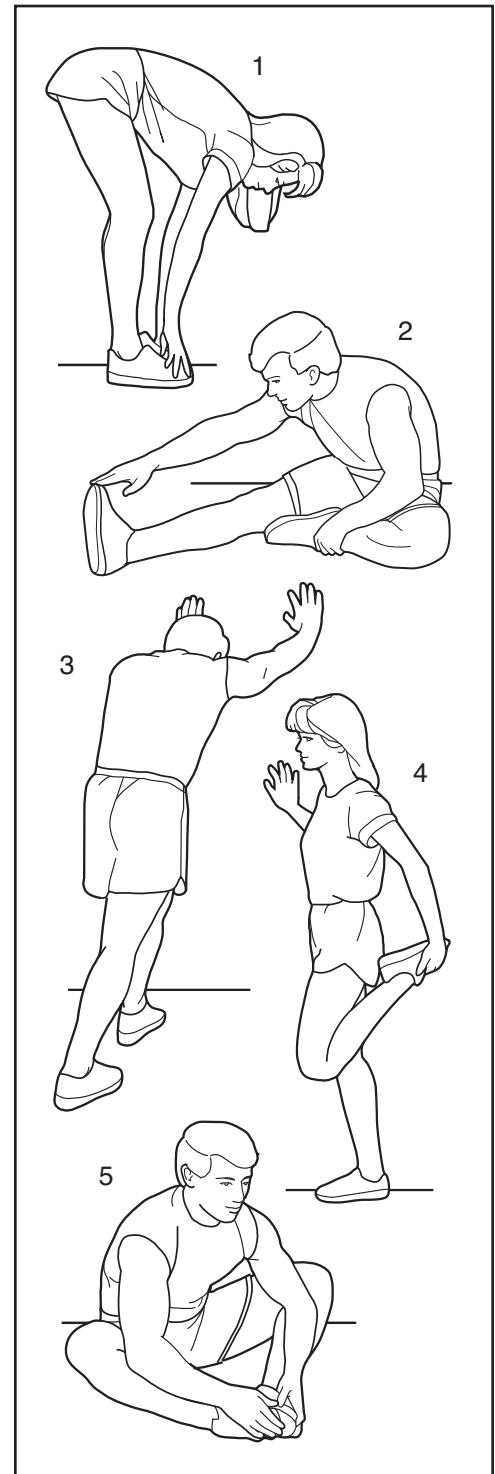

NOTES

PART LIST—Model No. NEL90952

R0105A

Key No.	Qty.	Description	Key No.	Qty.	Description	Key No.	Qty.	Description
1	1	Frame	45	1	Small Pulley	87	2	M8 x 16mm Washer
2	1	Rear Stabilizer	46	1	Idler Pulley	88	6	M8 x 23mm Flat Head Screw
3	1	Right Upright	47	1	Resistance Motor			
4	1	Left Upright	48	1	Power Board Cover	89	1	M8 x 57mm Screw
5	1	Incline Ramp	49	1	Power Board	90	1	M6 x 38mm Bolt
6	1	Console Frame	50	1	Power Board	91	1	Magnet Bracket Bolt
7	1	Lower Ramp Cap			Bracket	92	36	M4 x 16mm Screw
8	1	Power Cord	51	1	Idler Pulley Bracket	93	1	M6 x 8mm Button Screw
9	1	Right Handlebar	52	1	Reed Switch Clamp			
10	1	Left Handlebar	53	1	Reed Switch	94	8	M8 Washer
11	1	Right Pedal Arm	54	2	Pillow Block Set	95	2	M8 x 25mm Washer
12	1	Left Pedal Arm	55	2	Bearing Block Set	96	3	M8 x 9.5mm Screw
13	1	Right Pedal	56	4	Crank Arm Bushing	97	5	M5 x 16mm Bolt
14	1	Left Pedal	57	4	Pulley Spacer	98	2	M8 x 23mm Washer
15	2	Pivot Shaft	58	1	Crank Spacer	99	4	M8 x 28mm Washer
16	4	M4 Star Washer	59	4	Ramp Bushing	100	2	Wave Washer
17	1	Console	60	4	Incline Motor Spacer	101	12	M8 Split Washer
18	1	Hand Grip Pulse Sensor	61	4	Pedal Wheel Bushing	102	13	M8 Nylon Locknut
19	1	Rear Base Plate	62	4	Pivot Bushing	103	2	Large Snap Ring
20	1	Front Base Plate	63	2	Inner Upright Cover	104	2	Handlebar Endcap
21	1	Right Rear Side Shield	64	2	Pivot Arm Cover	105	8	M4 x 25mm Screw
22	1	Left Rear Side Shield	65	1	Magnet	106	8	M4 x 16mm Round Head Screw
23	1	Right Front Side Shield	66	1	Wedge	107	2	Bolt Set
24	1	Left Front Side Shield	67	1	Incline Reed Switch	108	4	M8 x 56mm Button Screw
25	1	Front Cover	68	1	Power Receptical			
26	1	Right Foot Rail	69	1	Belt	109	1	Reed Switch Plate
27	1	Left Foot Rail	70	1	Grommet	110	8	M8 x 68mm Button Screw
28	1	Upper Ramp Cap	71	2	Hairpin			
29	4	Pivot Shaft Sleeve	72	2	Snap Ring	111	8	M4 x 12mm Screw
30	4	Handlebar Cover	73	1	Flywheel Spacer	112	4	M8 x 76mm Button Bolt
31	4	Frame Endcap	74	2	Outer Upright Cover			
32	2	Frame Cushion	75	1	Upper Wire Harness	113	2	M8 x 20mm Button Screw
33	4	Leveling Foot	76	1	Extension Wire Harness	114	2	M6 Nut
34	2	Wheel	77	1	Lower Wire Harness	115	4	M6 x 10mm Button Screw
35	2	Pedal Wheel	78	4	M4 x 14mm Screw			
36	1	Flywheel	79	4	M5 Nylon Locknut	116	5	M4 x 19mm Screw
37	1	Pulley	80	2	M8 x 45mm Button Screw	117	2	M4 x 30mm Screw
38	1	Right Crank Arm	81	4	M8 x 25mm Button Screw	118	1	Short Clevis Pin
39	1	Left Crank Arm	82	4	M5 Washer	119	1	Long Clevis Pin
40	1	Incline Axle	83	2	Flange Screw	120	2	Foam Grip
41	1	Pulley Axle	84	2	M8 x 52mm Button Screw	121	1	Left Pedal Insert
42	1	Lift Motor	85	2	M8 x 41mm Button Screw	122	1	Right Pedal Insert
43	1	"C" Magnet			Screw	#	2	Hex Key
44	1	Spring	86	2	Large Wave Washer	#	1	Grease
						#	1	Teflon® Lubricant
						#	1	User's Manual

Note: # indicates a non-illustrated part. Specifications are subject to change without notice. See the back cover of this manual for information about ordering replacement parts.

EXPLODED DRAWING—Model No. NEL90952

R0105A

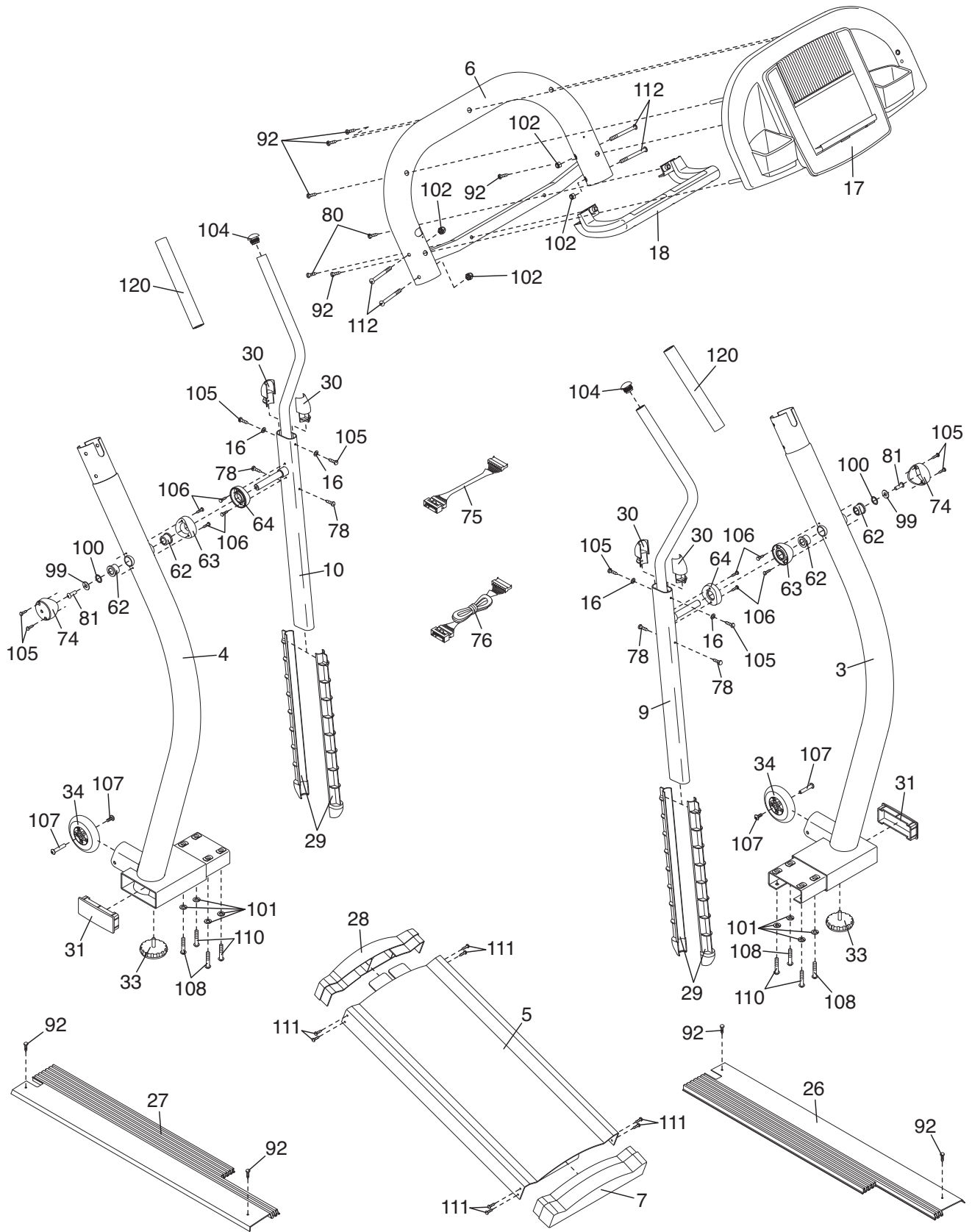

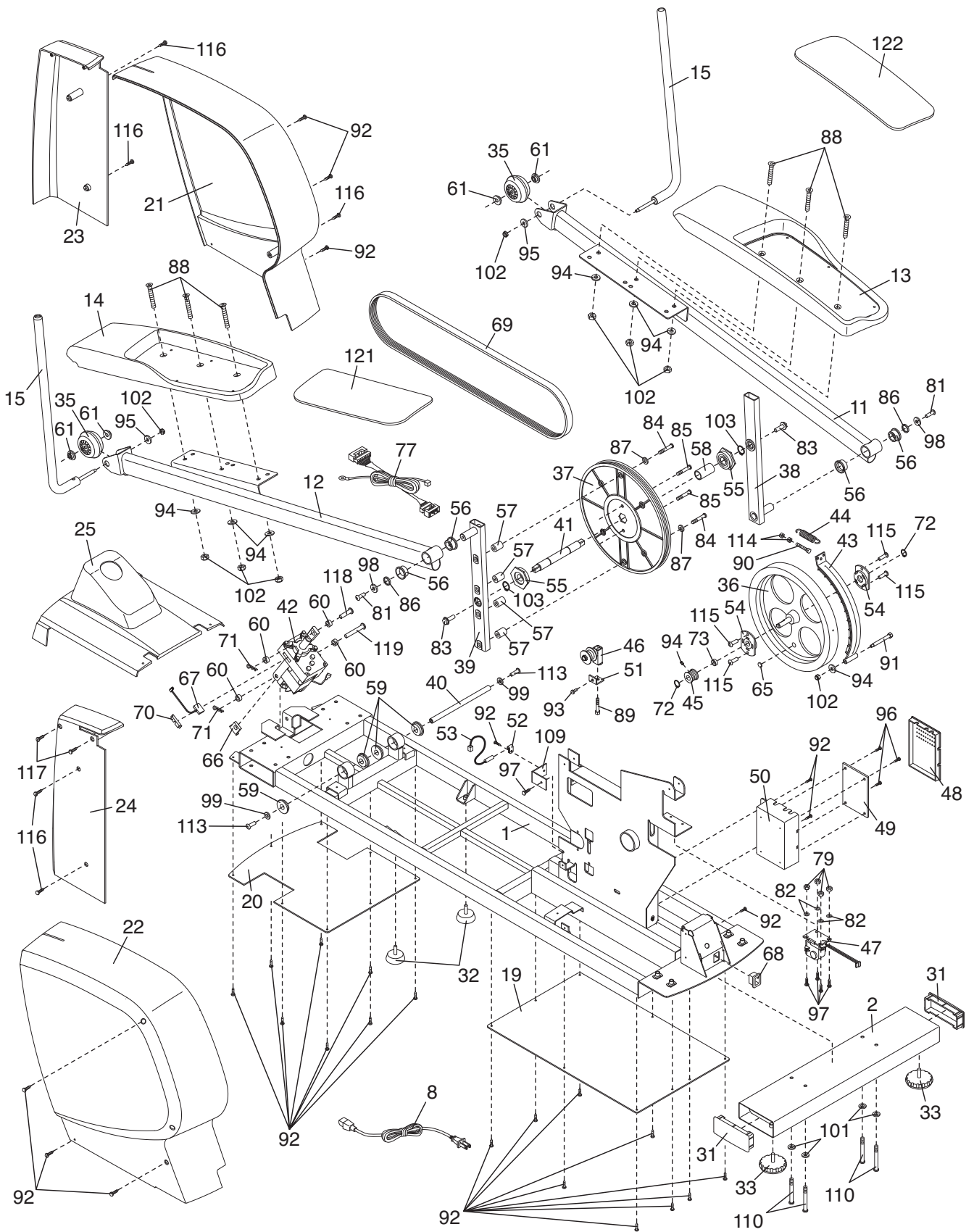

HOW TO ORDER REPLACEMENT PARTS

To order replacement parts, simply call our Customer Service Department toll-free at 1-888-825-2588, Monday through Friday, 6 a.m. until 6 p.m. Mountain Time (excluding holidays). To help us assist you, please be prepared to give the following information when calling:

- The MODEL NUMBER of the product (NEL90952)
- The NAME of the product (NordicTrack CX 1055 elliptical exerciser)
- The SERIAL NUMBER of the product (see the front cover of this manual)
- The KEY NUMBER and DESCRIPTION of the part(s) (see pages 25 to 27)

LIMITED WARRANTY

WHAT IS COVERED—The entire NordicTrack® elliptical exerciser (“Product”) is warranted to be free of all defects in material and workmanship.

WHO IS COVERED—The original purchaser or any person receiving the Product as a gift from the original purchaser.

HOW LONG IS IT COVERED—ICON Health & Fitness, Inc. (“ICON”), warrants the product for one year after the date of purchase. Labor is covered for one year.

WHAT WE DO TO CORRECT COVERED DEFECTS—We will ship to you, without charge, any replacement part or component, providing the repairs are authorized by ICON first and are performed by an ICON trained and authorized service provider, or, at our option, we will replace the Product.

WHAT IS NOT COVERED—Any failures or damage caused by unauthorized service, misuse, accident, negligence, improper assembly or installation, alterations, modifications without our written authorization or by failure on your part to use, operate, and maintain as set out in your User’s Manual (“Manual”).

WHAT YOU MUST DO—Always retain proof of purchase, such as your bill of sale; store, operate, and maintain the Product as specified in the Manual; notify our Customer Service Department of any defect within 10 days after discovery of the defect; as instructed, return any defected part for replacement or, if necessary, the entire product, for repair.

USER’S MANUAL—It is VERY IMPORTANT THAT YOU READ THE MANUAL before operating the Product. Remember to do the periodic maintenance requirements specified in the Manual to assure proper operation and your continued satisfaction.

HOW TO GET PARTS AND SERVICE—Simply call our Customer Service Department at 1-888-825-2588 and tell them your name and address and the serial number of your Product. They will tell you how to get a part replaced, or if necessary, arrange for service where your Product is located or advise you how to ship the Product for service. Before shipping, always obtain a Return Authorization Number (RA No.) from our Customer Service Department; securely pack your Product (save the original shipping carton if possible); put the RA No. on the outside of the carton and insure the product. Include a letter explaining the product or problem and a copy of your proof of purchase if you believe the service is covered by warranty.

ICON is not responsible or liable for indirect, special or consequential damages arising out of or in connection with the use or performance of the product or damages with respect to any economic loss, loss of property, loss of revenues or profits, loss of enjoyment or use, costs of removal, installation or other consequential damages of whatsoever nature. Some states do not allow the exclusion or limitation of incidental or consequential damages. Accordingly, the above limitation may not apply to you.

The warranty extended hereunder is in lieu of any and all other warranties and any implied warranties of merchantability or fitness for a particular purpose is limited in its scope and duration to the terms set forth herein. Some states do not allow limitations on how long an implied warranty lasts. Accordingly, the above limitation may not apply to you.

No one is authorized to change, modify or extend the terms of this limited warranty. This warranty gives you specific legal rights and you may have other rights which vary from state to state.

ICON HEALTH & FITNESS, INC., 1500 S. 1000 W., LOGAN, UT 84321-9813