

PRO-FORM®

COMFORT STRIDE

www.proform.com

Model No. PFEL04211.0

Serial No. _____

Write the serial number in the space above for reference.

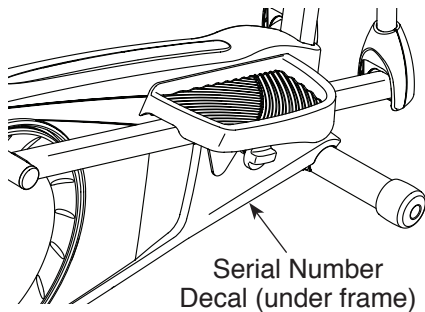

USER'S MANUAL

QUESTIONS?

If you have questions, or if parts are damaged or missing, **DO NOT CONTACT THE STORE**; please contact Customer Care.

IMPORTANT: Please register this product (see the limited warranty on the back cover of this manual) before contacting Customer Care.

CALL TOLL-FREE:

1-888-533-1333

Mon.–Fri. 6 a.m.–6 p.m. MT

Sat. 8 a.m.–4 p.m. MT

ON THE WEB:

www.proformservice.com

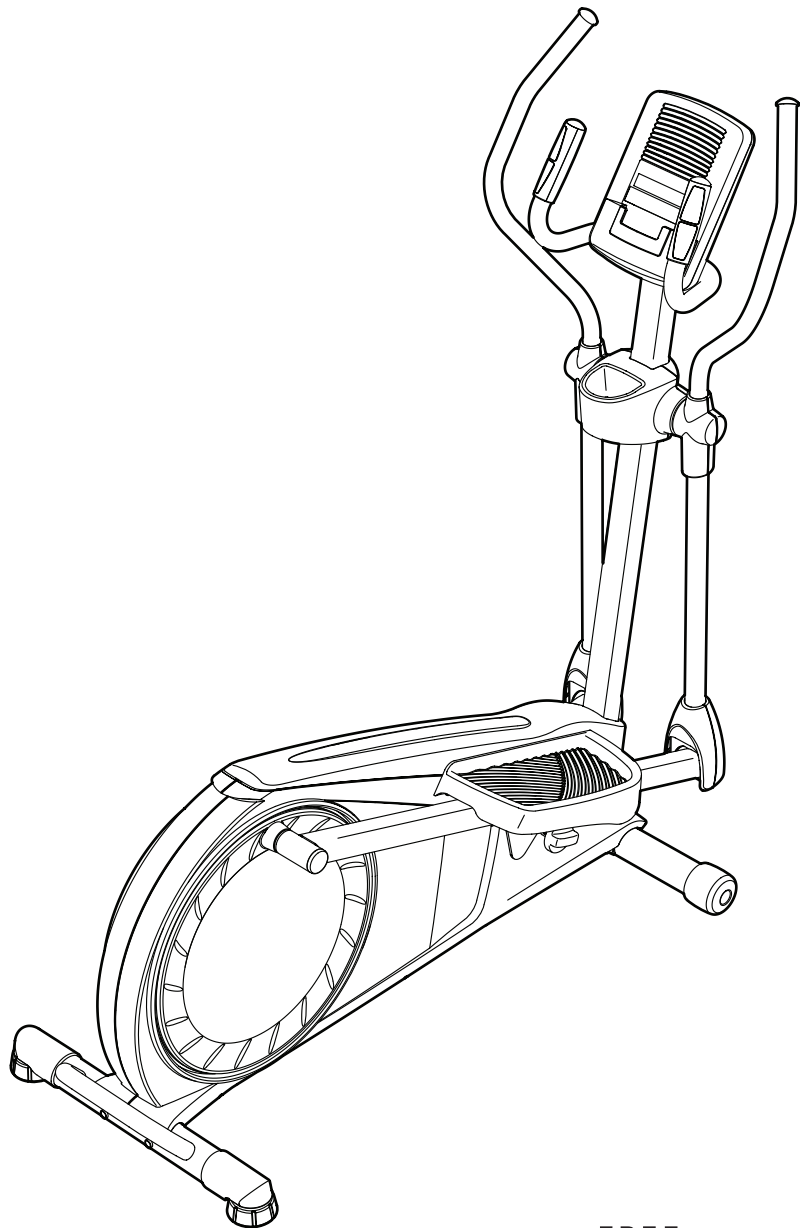

CAUTION

Read all precautions and instructions in this manual before using this equipment. Keep this manual for future reference.

FREE

  HOW-TO VIDEOS

www.iFit.com

TABLE OF CONTENTS

WARNING DECAL PLACEMENT	2
IMPORTANT PRECAUTIONS	3
BEFORE YOU BEGIN	4
PART IDENTIFICATION CHART	5
ASSEMBLY	6
HOW TO USE THE ELLIPTICAL	14
FCC INFORMATION	20
MAINTENANCE AND TROUBLESHOOTING	21
EXERCISE GUIDELINES	23
PART LIST	24
EXPLODED DRAWING	26
ORDERING REPLACEMENT PARTS	Back Cover
LIMITED WARRANTY	Back Cover

WARNING DECAL PLACEMENT

This drawing shows the location(s) of the warning decal(s). **If a decal is missing or illegible, see the front cover of this manual and request a free replacement decal. Apply the decal in the location shown.** Note: The decal(s) may not be shown at actual size.

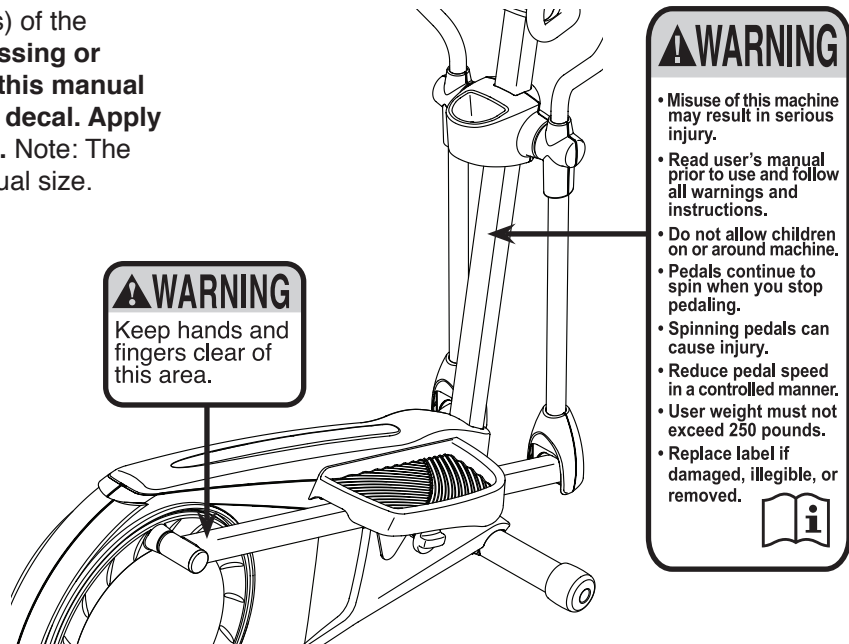

IMPORTANT PRECAUTIONS

⚠️ WARNING: To reduce the risk of serious injury, read all important precautions and instructions in this manual and all warnings on your elliptical before using your elliptical. ICON assumes no responsibility for personal injury or property damage sustained by or through the use of this product.

1. Before beginning any exercise program, consult your physician. This is especially important for persons over age 35 or persons with pre-existing health problems.
2. Use the elliptical only as described in this manual.
3. It is the responsibility of the owner to ensure that all users of the elliptical are adequately informed of all precautions.
4. The elliptical is intended for home use only. Do not use the elliptical in a commercial, rental, or institutional setting.
5. Keep the elliptical indoors, away from moisture and dust. Do not put the elliptical in a garage or covered patio, or near water.
6. Place the elliptical on a level surface, with at least 3 ft. (0.9 m) of clearance in the front and rear of the elliptical and 2 ft. (0.6 m) on each side. To protect the floor or carpet from damage, place a mat under the elliptical.
7. Inspect and properly tighten all parts regularly. Replace any worn parts immediately.
8. Keep children under age 12 and pets away from the elliptical at all times.
9. The elliptical should not be used by persons weighing more than 250 lbs. (113 kg).
10. Wear appropriate clothes while exercising; do not wear loose clothes that could become caught on the elliptical. Always wear athletic shoes for foot protection while exercising.
11. Hold the handlebars or the upper body arms when mounting, dismounting, or using the elliptical.
12. The heart rate monitor is not a medical device. Various factors may affect the accuracy of heart rate readings. The heart rate monitor is intended only as an exercise aid in determining heart rate trends in general.
13. The elliptical does not have a freewheel; the pedals will continue to move until the flywheel stops. Reduce your pedaling speed in a controlled way.
14. Keep your back straight while using the elliptical; do not arch your back.
15. Over exercising may result in serious injury or death. If you feel faint or if you experience pain while exercising, stop immediately and cool down.

BEFORE YOU BEGIN

Thank you for selecting the revolutionary PROFORM® COMFORT STRIDE elliptical. The COMFORT STRIDE elliptical provides an impressive selection of features designed to make your workouts at home more effective and enjoyable.

For your benefit, read this manual carefully before you use the elliptical. If you have questions after

reading this manual, please see the front cover of this manual. To help us assist you, note the product model number and serial number before contacting us. The model number and the location of the serial number decal are shown on the front cover of this manual.

Before reading further, please familiarize yourself with the parts that are labeled in the drawing below.

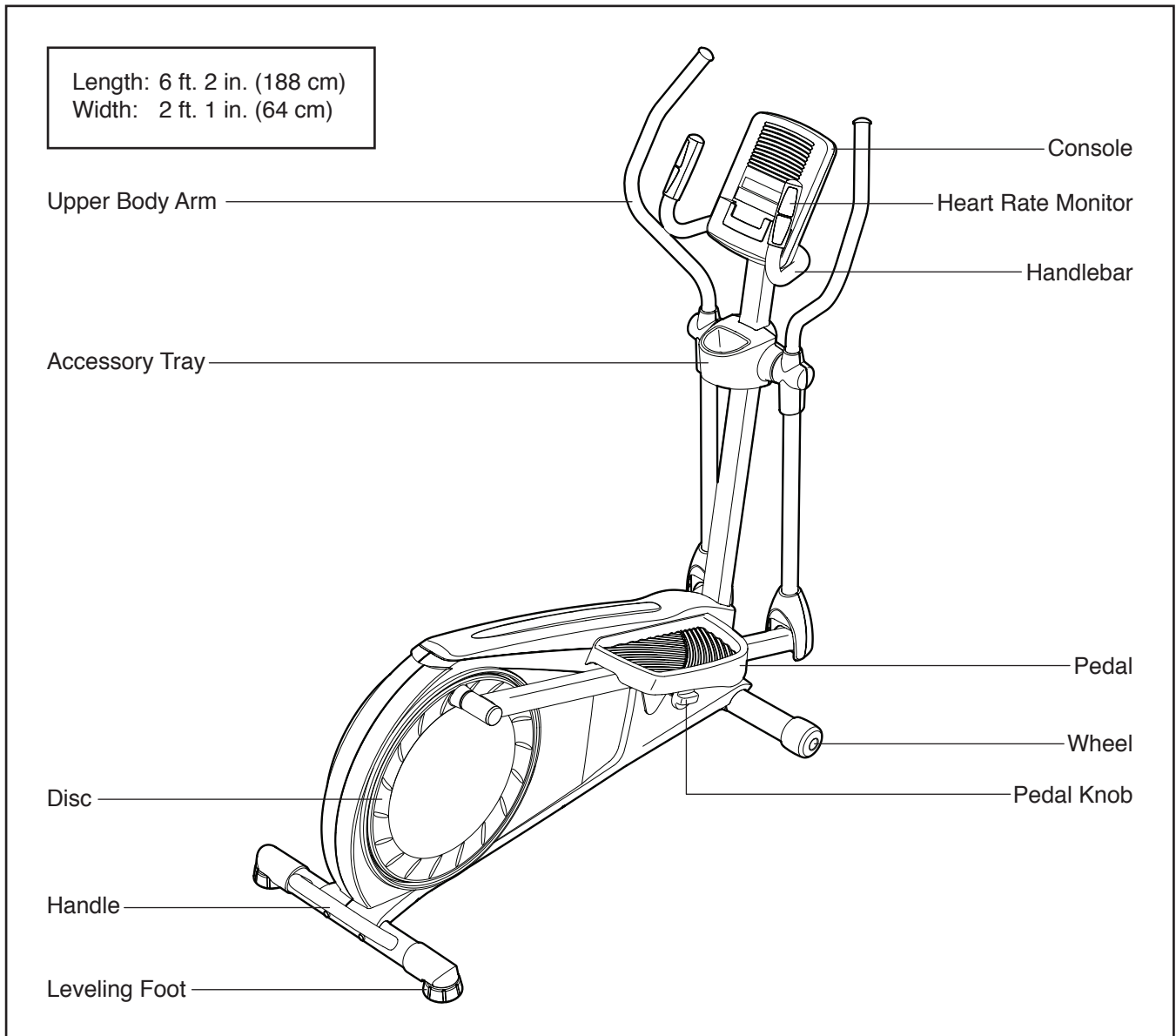

PART IDENTIFICATION CHART

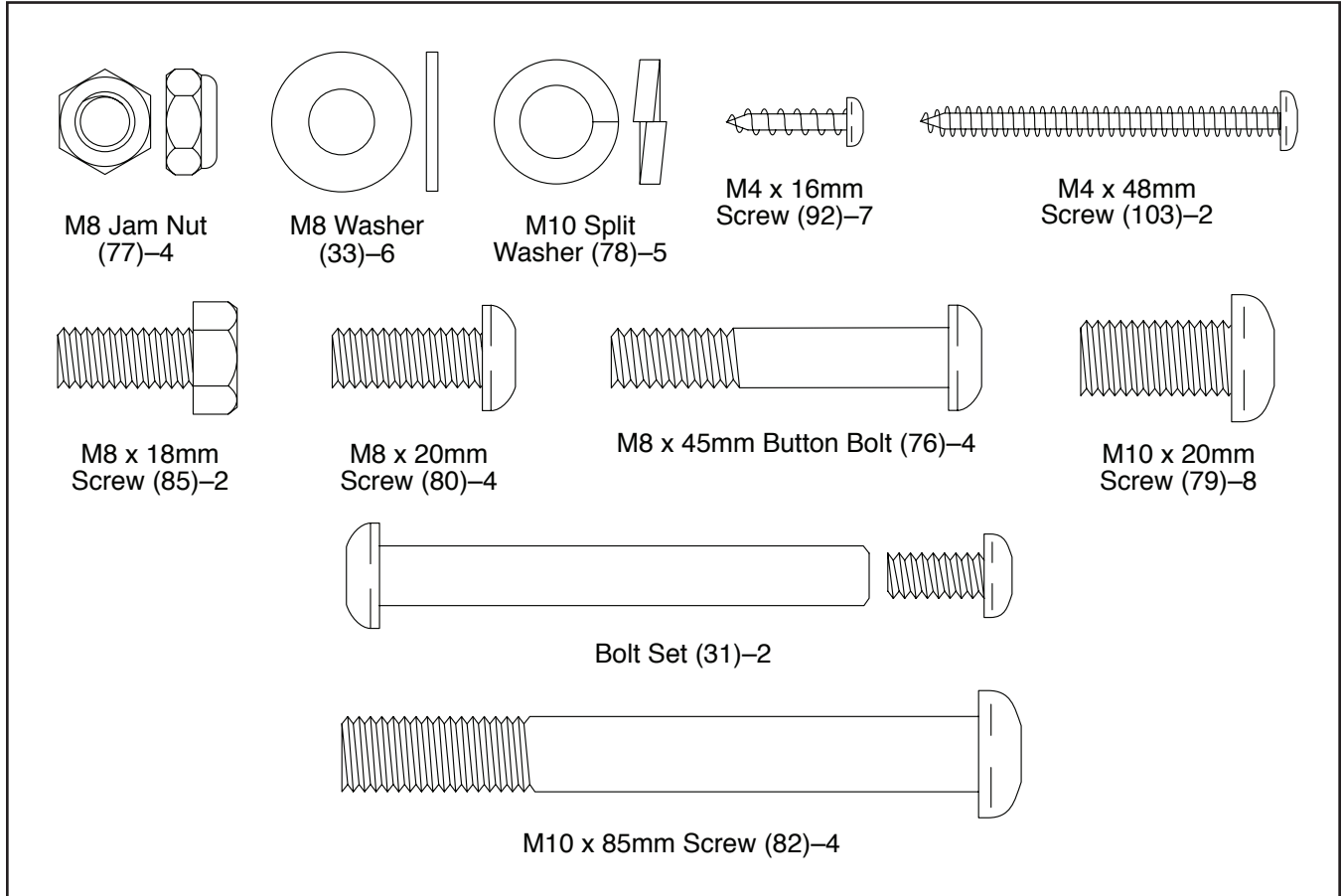

Use the drawings below to identify the small parts needed for assembly. The number in parentheses below each drawing is the key number of the part, from the PART LIST near the end of this manual. The number following the key number is the quantity needed for assembly. **Note: If a part is not in the hardware kit, check to see if it has been preassembled.**



ASSEMBLY

- To hire an authorized service technician to assemble the elliptical, call 1-800-445-2480.
- Assembly requires two persons.
- Place all parts in a cleared area and remove the packing materials. Do not dispose of the packing materials until you complete all assembly steps.
- To identify small parts, see page 5.

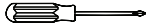
- In addition to the included tool(s), assembly requires the following tools:

- one adjustable wrench 
- one Phillips screwdriver 
- one rubber mallet 

Assembly may be easier if you have your own set of wrenches. To avoid damaging parts, do not use power tools.

1. While a second person lifts the rear of the Frame (1), attach the Rear Stabilizer (70) to the Frame with two M10 x 85mm Screws (82).

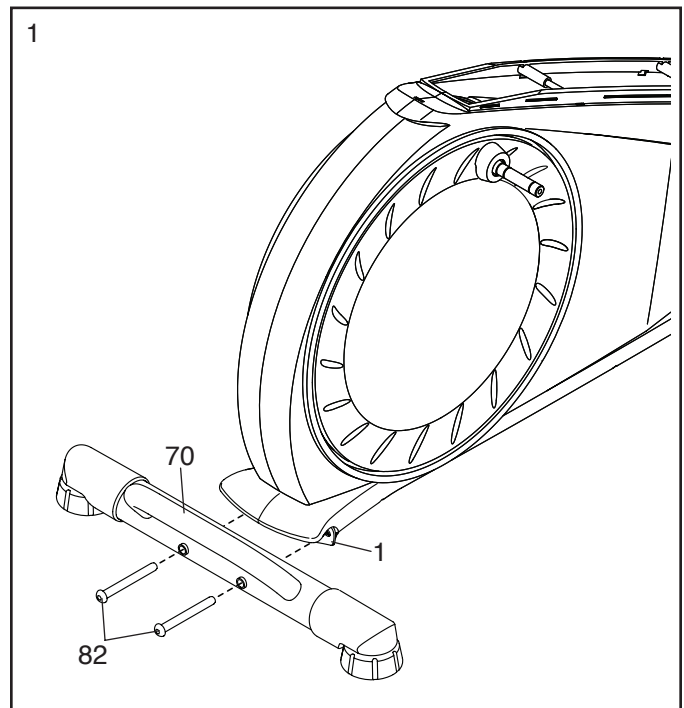

2. Orient the Front Stabilizer (73) as indicated by the sticker.

While a second person lifts the front of the Frame (1), attach the Front Stabilizer (73) to the Frame with two M10 x 85mm Screws (82).

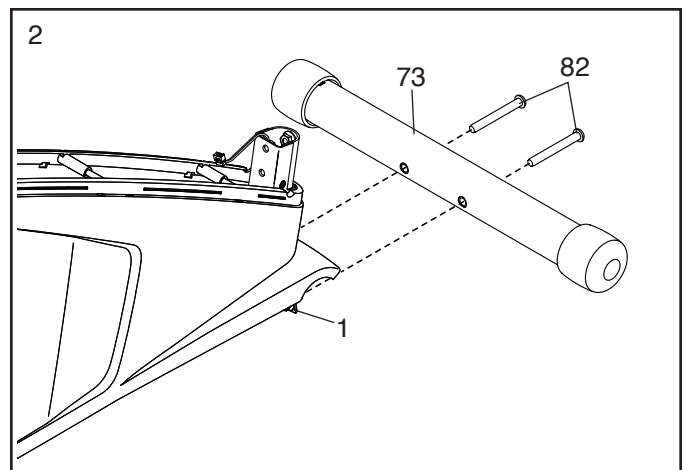

- Orient the Upright (2) and the Shield Cover (37) as shown. Slide the Shield Cover upward onto the Upright.

Have a second person hold the Upright (2) and the Shield Cover (37) near the Frame (1).

Locate the wire tie in the lower end of the Upright (2). Tie the wire tie to the Main Wire (42). Then, pull the upper end of the wire tie until the Main Wire is routed through the Upright.

Tip: To prevent the Main Wire (42) from falling into the Upright (2), secure the Main Wire with the wire tie.

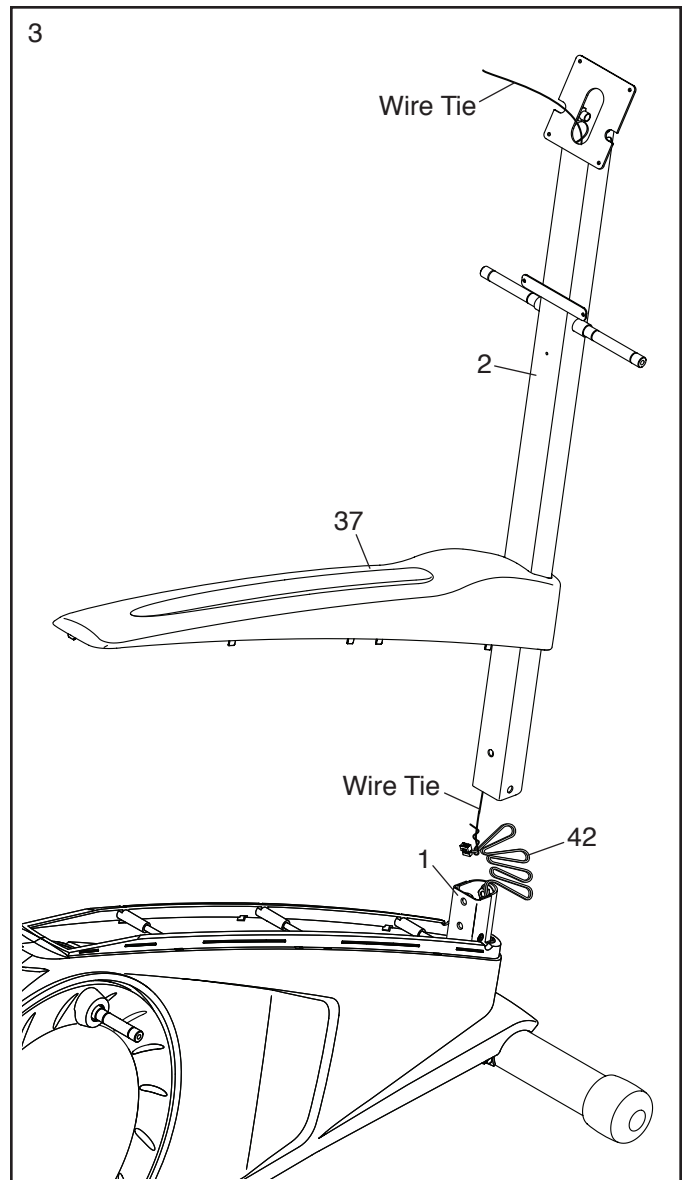

- Tip: Avoid pinching the Main Wire (42).** Slide the Upright (2) onto the Frame (1).

Have a second person hold the Shield Cover (37) out of the way.

Attach the Upright (2) with five M10 x 20mm Screws (79) and five M10 Split Washers (78).

Tip: Start all five Screws, and then tighten them.

Press the Shield Cover (37) into the Left and Right Shields (44, 45).

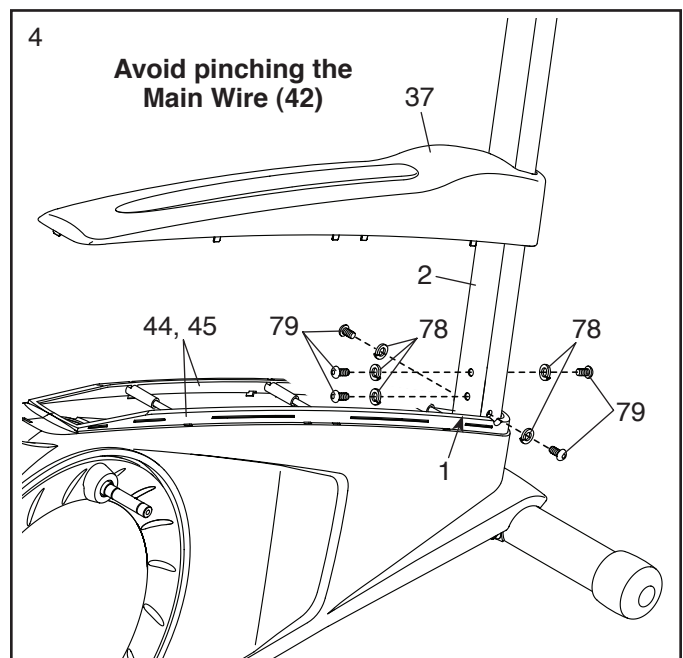

5. Orient the Handlebar (39) as shown. Have a second person hold the Handlebar near the Upright (2).

Locate the Sensor Wires (28) in the Handlebar (39). Insert the right Sensor Wire into the right side of the Upright, and insert the left Sensor Wire into the left side of the Upright. Then, pull the Sensor Wires upward out of the top of the Upright.

Tip: Avoid pinching the wires. Attach the Handlebar (39) to the Upright (2) with three M10 x 20mm Screws (79).

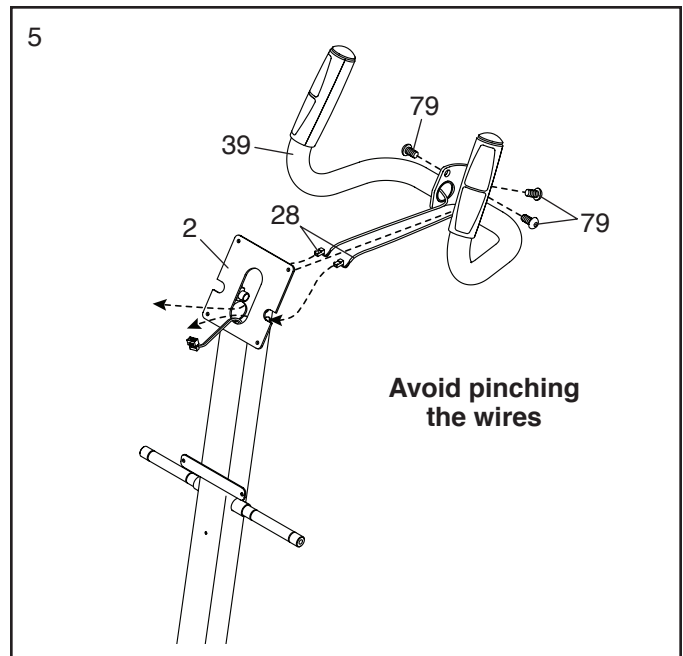

6. The Console (4) can use four D batteries (not included); alkaline batteries are recommended. Do not use old and new batteries together or alkaline, standard, and rechargeable batteries together. **IMPORTANT: If the Console has been exposed to cold temperatures, allow it to warm to room temperature before you insert batteries. Otherwise, you may damage the console display or other electronic components.** Remove the screws, remove the battery covers, and insert batteries into the battery compartments. **Make sure to orient the batteries as shown by the diagrams inside the battery compartments.** Then, reattach the battery covers.

To purchase an optional power adapter, call the telephone number on the cover of this manual. To avoid damaging the console, use only a manufacturer-supplied power adapter. Plug one end of the power adapter into the receptacle on the console; plug the other end into an outlet installed in accordance with all local codes and ordinances.

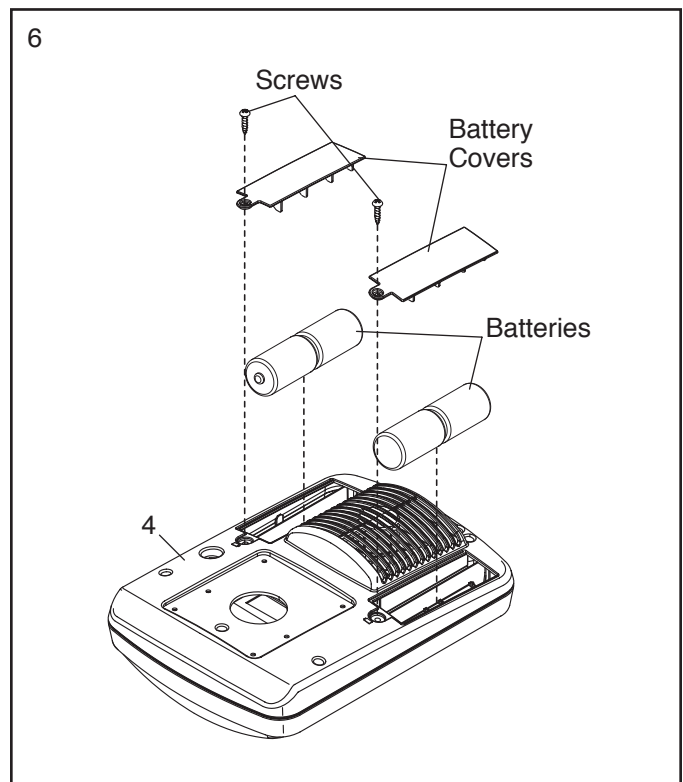

7. Untie and discard the wire tie on the Main Wire (42).

While a second person holds the Console (4) near the Upright (2), connect the wires on the Console to the Main Wire (42) and to the Sensor Wires (28).

Insert the excess wire into the Upright (2) or into the Console (4).

Tip: Avoid pinching the wires. Attach the Console (4) to the Upright (2) with four M4 x 16mm Screws (92).

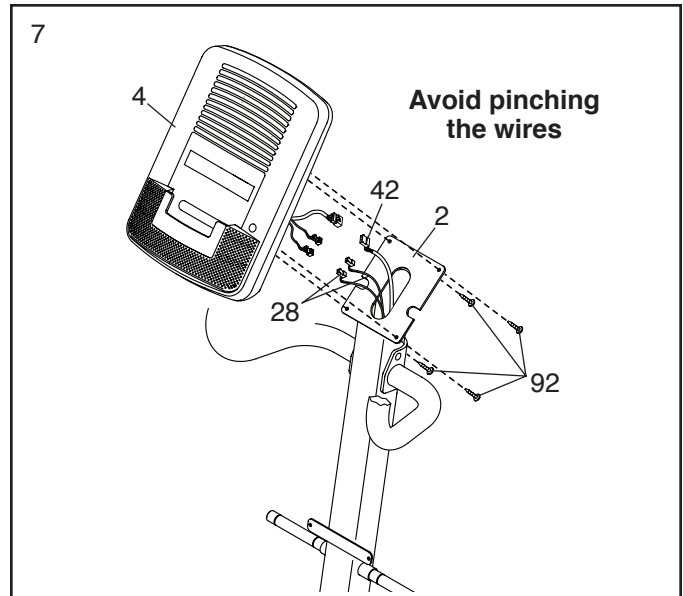

8. Attach the Console Cover (32) to the Console (4) with two M4 x 48mm Screws (103).

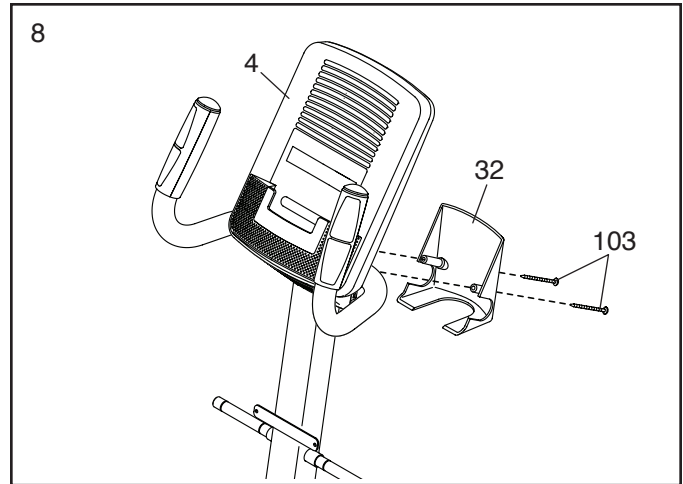

9. Identify the Right Pedal Arm (49), which is marked with a "Right" sticker.

Slide the Right Pedal Arm (49) onto the Right Crank Arm (25). Attach the Right Pedal Arm with an M8 x 18mm Screw (85) and an M8 Washer (33). Then, press a Pedal Arm Cap (30) onto the Right Pedal Arm.

While a second person lifts the back of the Right Pedal (13), insert one of the Cam Axles (75) into the Right Pedal Arm (49). Attach the Cam Axle with an M8 x 20mm Screw (80) and an M8 Washer (33). **Do not overtighten the Screw; the Cam Axle should turn freely.**

Repeat this step on the other side of the elliptical.

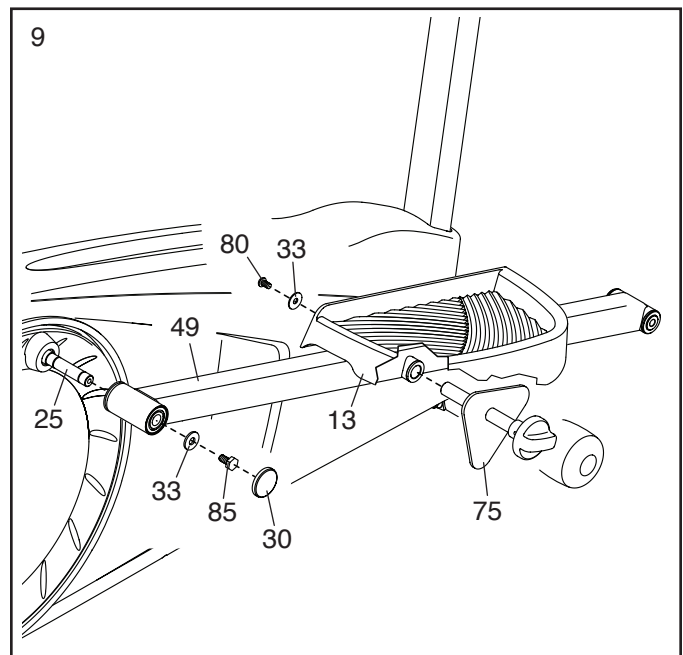

10. Identify the Right Upper Body Arm (9), which is marked with an "R" sticker.

Orient the Right Upper Body Arm (9) and one of the Upper Body Legs (6) as shown. Insert the Right Upper Body Arm into the Upper Body Leg.

Attach the Right Upper Body Arm (9) to the Upper Body Leg (6) with two M8 x 45mm Button Bolts (76) and two M8 Jam Nuts (77). **Make sure that the Jam Nuts are inside the hexagonal holes.** Do not fully tighten the Button Bolts yet.

Attach the Left Upper Body Arm (8) to the other Upper Body Leg (6) in the same way.

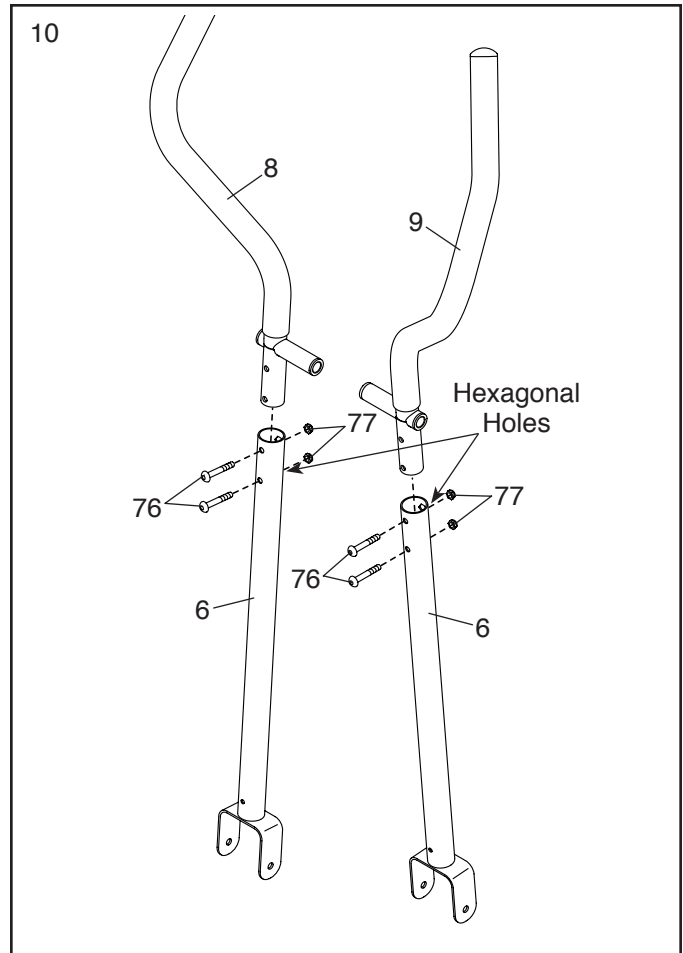

11. Using a small plastic bag to keep your fingers clean, apply a generous amount of the included grease to the axle on the right side of the Upright (2).

Slide the Right Upper Body Arm (9) onto the Upright (2).

Attach the Right Upper Body Arm (9) with an M8 x 20mm Screw (80) and an M8 Washer (33).

Repeat this step on the other side of the elliptical.

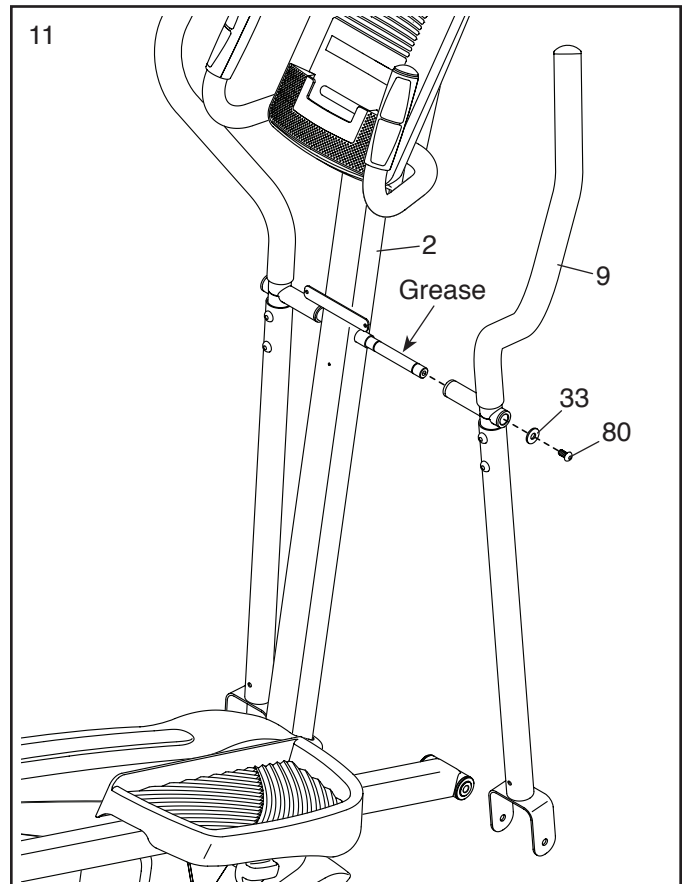

12. Apply a small amount of grease to a Bolt Set (31).

Hold the end of the Right Pedal Arm (49) inside the bracket on the right Upper Body Leg (6).

Attach the right Upper Body Leg (6) to the Right Pedal Arm (49) with the Bolt Set (31).

Repeat this step on the other side of the elliptical.

Tighten the M8 x 45mm Button Bolts (76).

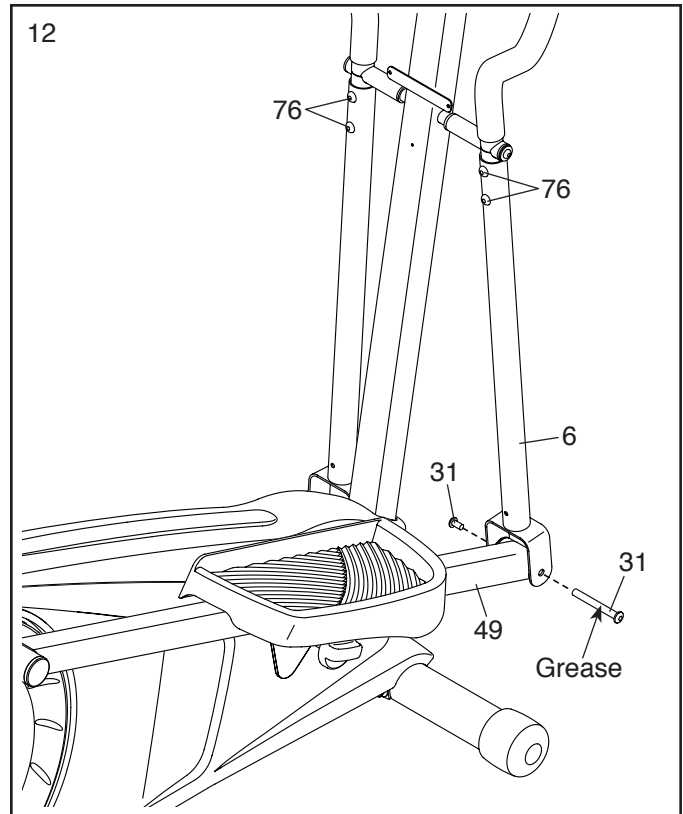

13. Identify a Pivot Cover A (19), which has hooks, and a Pivot Cover B (22), which has tabs.

Attach a Pivot Cover A (19) and a Pivot Cover B (22) around the Right Upper Body Arm (9) by pressing the hooks on the Pivot Cover A onto the tabs on the Pivot Cover B.

Repeat this step on the other side of the elliptical.

Tip: Make sure that the Pivot Covers (19, 22) are positioned as shown.

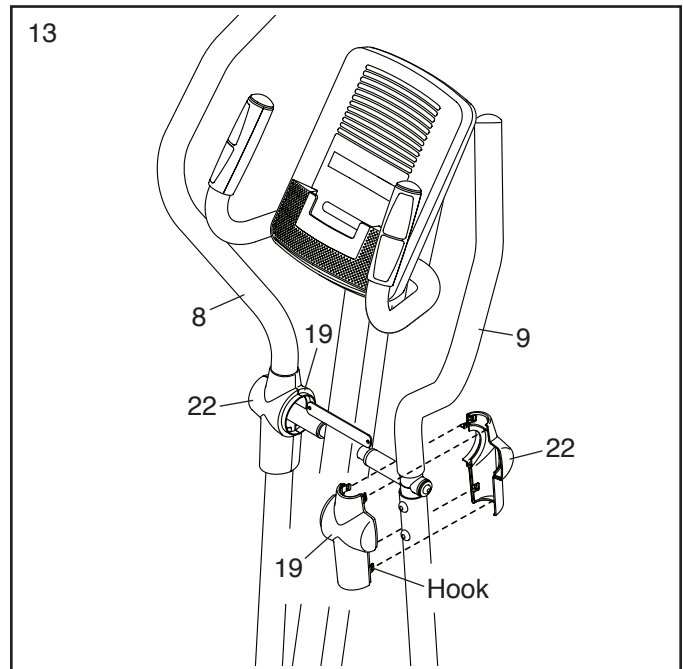

14. Attach the Rear Upright Cover (3) to the Upright (2) with three M4 x 16mm Screws (92).

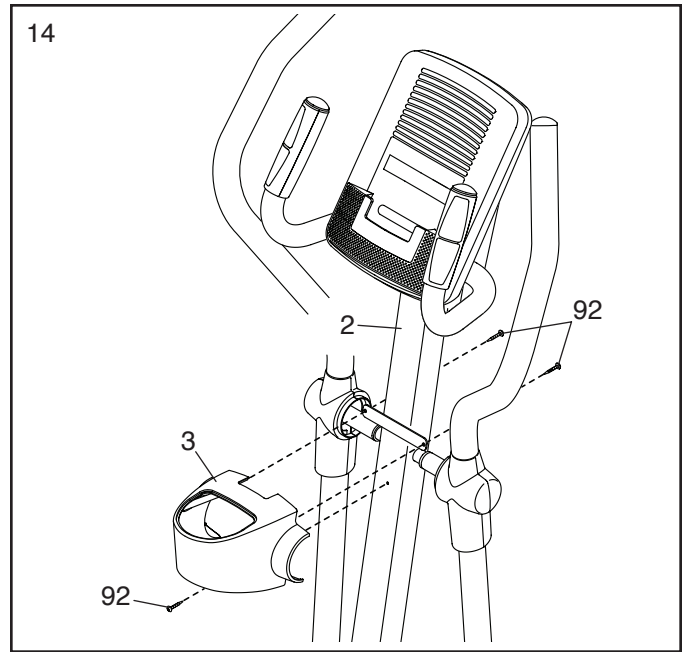

15. Attach the Front Upright Cover (16) around the Upright (2) by pressing the hooks on the Front Upright Cover onto the tabs on the Rear Upright Cover (3).

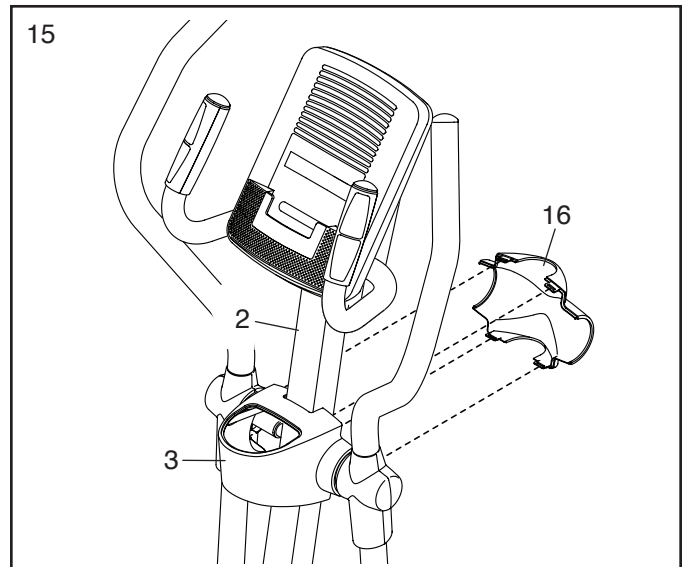

16. Insert the Accessory Tray (5) into the Rear Upright Cover (3).

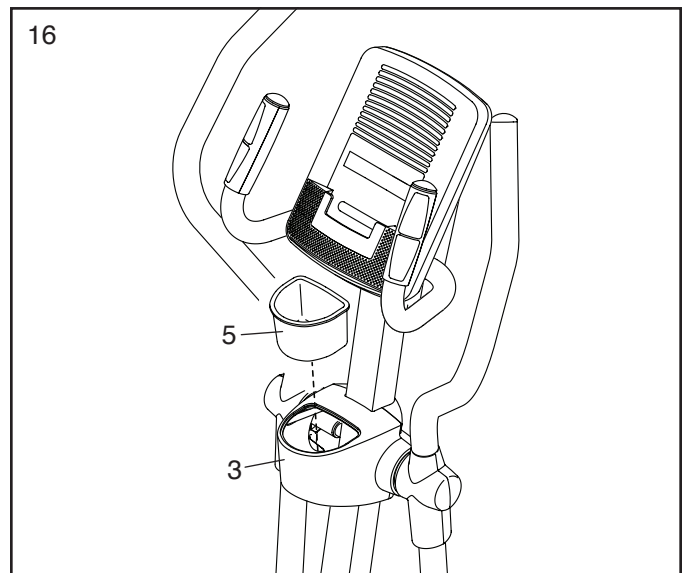

17. Attach a Front Leg Cover (20) and a Rear Leg Cover (21) around the right Upper Body Leg (6) by pressing the hooks on the Front Leg Cover onto the tabs on the Rear Leg Cover.

Repeat this step on the other side of the elliptical.

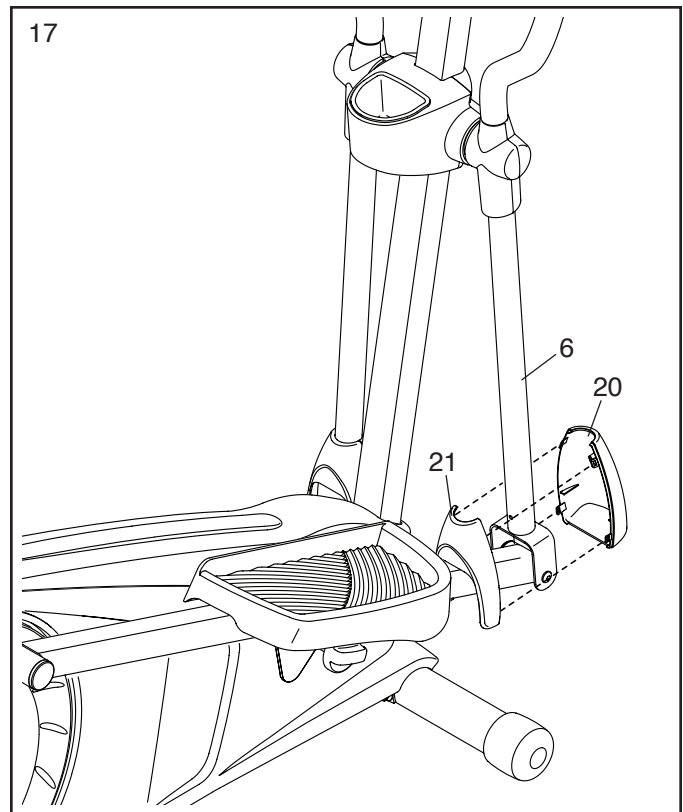

18. **Make sure that all parts of the elliptical are properly tightened.** Note: Some hardware may be left over after assembly is completed. To protect the floor or carpet from damage, place a mat under the elliptical.

HOW TO USE THE ELLIPTICAL

HOW TO MOVE THE ELLIPTICAL

Due to the size and weight of the elliptical, moving it requires two persons. Stand in front of the elliptical, hold the upright, and place one foot against one of the wheels. Pull on the upright and have a second person lift the handle on the rear stabilizer until the elliptical will roll on the wheels. Carefully move the elliptical to the desired location, and then lower it to the floor.

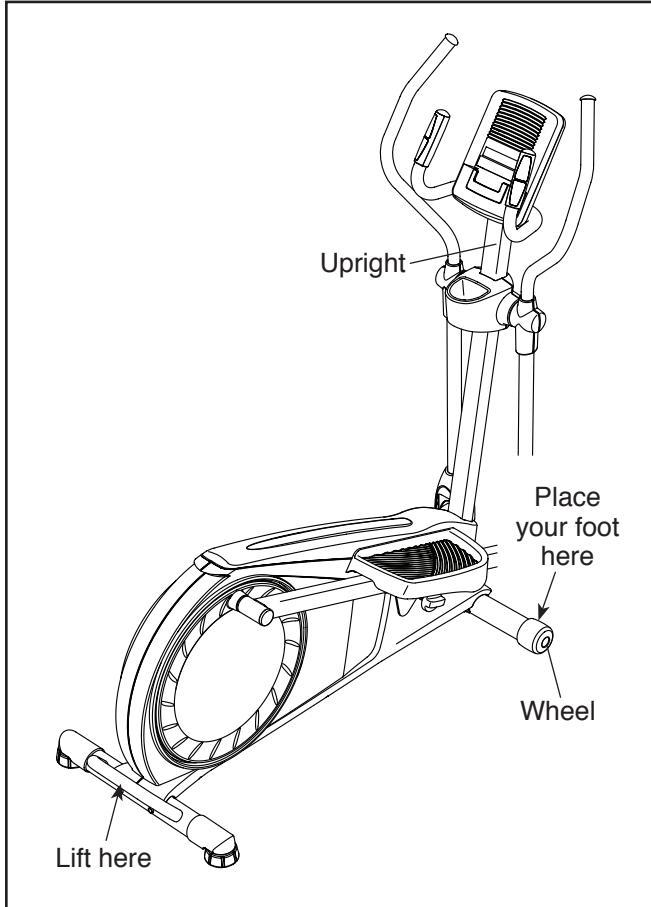

HOW TO LEVEL THE ELLIPTICAL

If the elliptical rocks slightly on your floor during use, turn one or both of the leveling feet beneath the rear stabilizer until the rocking motion is eliminated.

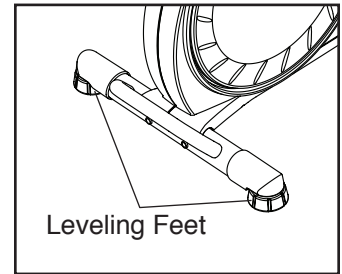

HOW TO ADJUST THE POSITIONS OF THE PEDALS

Each pedal can be adjusted to several positions. To adjust each pedal, lift the pedal and turn the pedal knob beneath the pedal. **Make sure to adjust both pedals to the same position.**

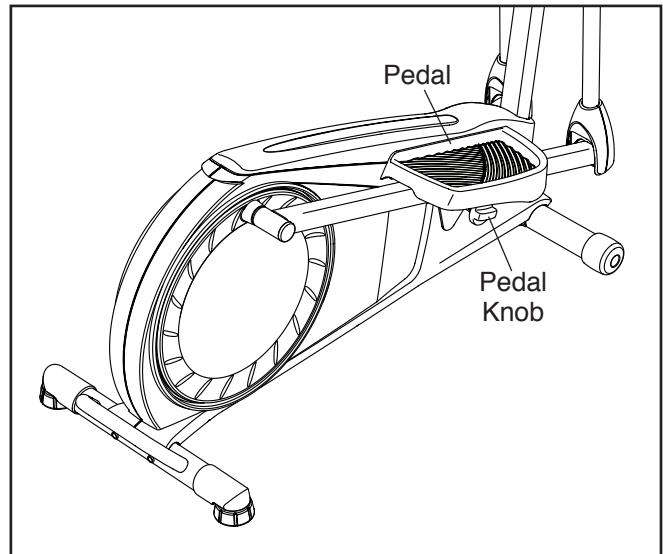

HOW TO EXERCISE ON THE ELLIPTICAL

To mount the elliptical, hold the handlebars or the upper body arms and step onto the pedal that is in the lowest position. Then, step onto the other pedal.

Push the pedals until they begin to move with a continuous motion. **Note: The pedal discs can turn in either direction. It is recommended that you move the pedal discs in the direction shown by the arrow; however, for variety, you can turn the pedal discs in the opposite direction.**

To dismount the elliptical, wait until the pedals come to a complete stop. **Note: The elliptical does not have a free wheel; the pedals will continue to move until the flywheel stops.** When the pedals are stationary, step off the highest pedal first. Then, step off the lowest pedal.

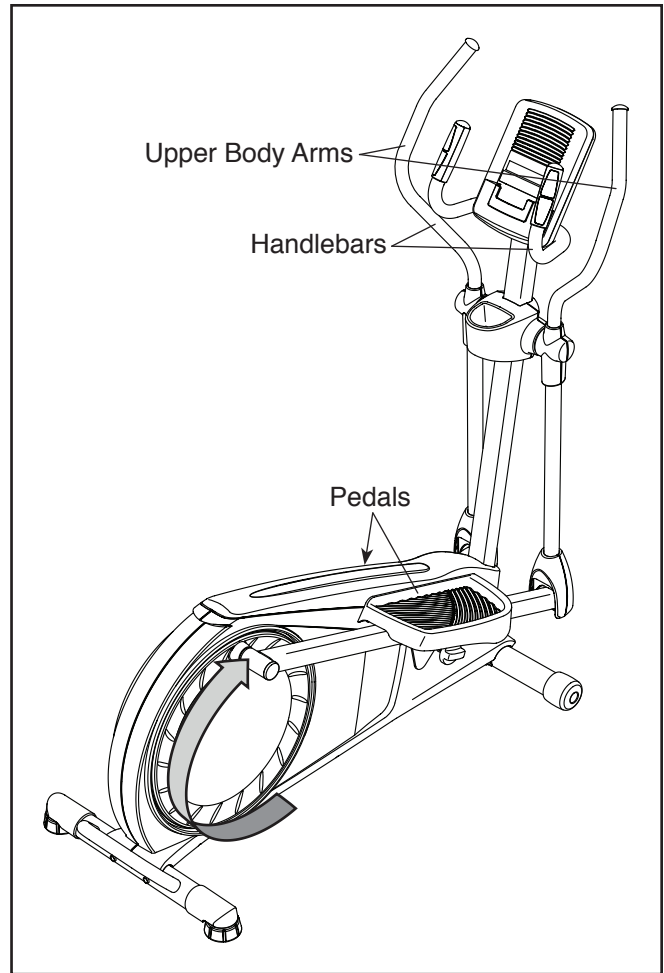

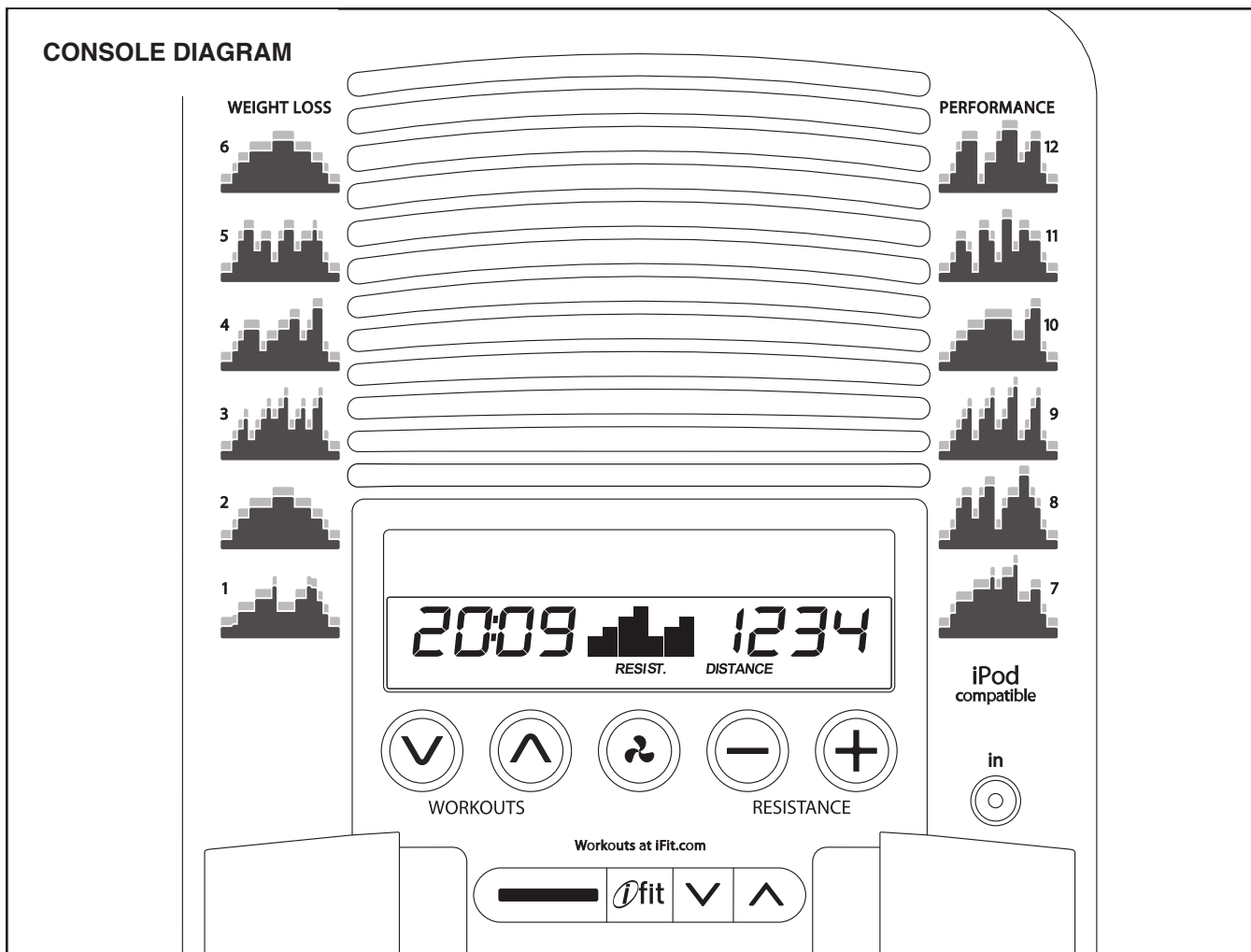

FEATURES OF THE CONSOLE

The advanced console offers an array of features designed to make your workouts more effective and enjoyable.

When you use the manual mode of the console, you can change the resistance of the pedals with the touch of a button. As you exercise, the console will provide continuous exercise feedback. You can even measure your heart rate using the handgrip heart rate monitor.

The console offers twelve preset workouts. Each preset workout automatically changes the resistance of the pedals as it guides you through an effective workout.

The console also features the iFit interactive workout system, which enables the console to accept iFit cards containing workouts designed to help you achieve specific fitness goals.

For example, lose unwanted pounds with the 8-week Weight Loss workout. iFit workouts control the resistance of the pedals while the voice of a personal trainer coaches you through your workouts. iFit cards are available separately. **To purchase iFit cards, go to www.iFit.com or call the telephone number on the front cover of this manual. iFit cards are also available at select stores.**

You can even connect your MP3 player or CD player to the console sound system and listen to your favorite music or audio books while you exercise.

To use the manual mode, see page 17. To use a preset workout, see page 18. To use an iFit workout, see page 19. To use the sound system, see page 20.

Note: Before using the console, make sure that batteries are installed (see assembly step 6 on page 8). If there is a sheet of plastic on the display, remove the plastic.

HOW TO USE THE MANUAL MODE

1. Turn on the console.

Press any button or begin pedaling to turn on the console.

When you turn on the console, the display will turn on. A tone will sound and the console will be ready for use.

2. Select the manual mode.

When you turn on the console, the manual mode will be selected.

If you have selected a workout, reselect the manual mode by pressing the Workouts increase or decrease button repeatedly until a track appears in the center display.

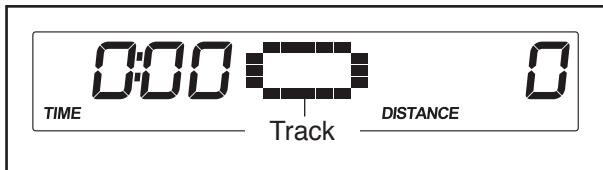

3. Begin pedaling and change the resistance of the pedals as desired.

As you pedal, change the resistance of the pedals by pressing the Resistance increase and decrease buttons.



Note: After you press the buttons, it will take a moment for the pedals to reach the selected resistance level.

4. Follow your progress with the display.

The left display—This display can show the elapsed time and the approximate number of calories you have burned. The display will change modes every few seconds.

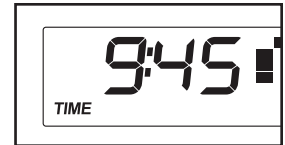

Note: During a preset workout, the display will show the time remaining in the workout.

The left display will also show your heart rate when you use the handgrip heart rate monitor (see step 5 on page 18).

The center display—This display will show the resistance level of the pedals for a few seconds each time the resistance level changes.

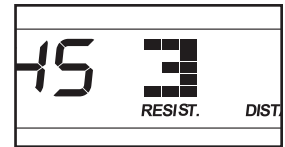

This display will also show a track representing 1/4 mile (400 m). As you exercise, indicators will appear in succession around the track until the entire track appears. The track will then disappear and the indicators will again begin to appear in succession.

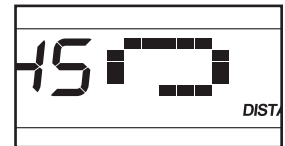

The right display—This display can show the distance you have pedaled in total revolutions. The display will change modes every few seconds.

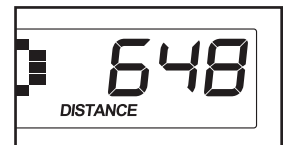

5. Measure your heart rate if desired.

If there are sheets of plastic on the metal contacts on the handgrip heart rate monitor, remove the plastic. In addition, make sure that your hands are clean. To measure your heart rate, hold the handgrip heart rate monitor with your palms resting against the contacts. **Avoid moving your hands or gripping the contacts tightly.**

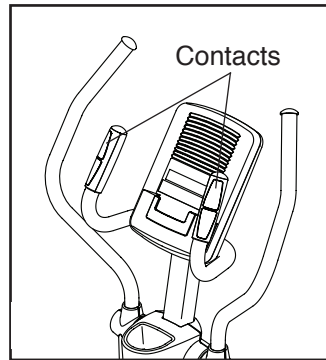

When your pulse is detected, a heart-shaped symbol will flash in the display and then your heart rate will be shown. For the most accurate heart rate reading, hold the contacts for at least 15 seconds.

If your heart rate is not shown, make sure that your hands are positioned as described. Be careful not to move your hands excessively or to squeeze the contacts tightly. For optimal performance, clean the contacts using a soft cloth; **never use alcohol, abrasives, or chemicals to clean the contacts.**

6. Turn on the fan if desired.

The fan has high and low speed settings. Press the Fan button repeatedly to select a fan speed or to turn off the fan.

Note: If the pedals do not move for about thirty seconds, the fan will turn off automatically.

7. When you are finished exercising, the console will turn off automatically.

If the pedals do not move for several seconds, a series of tones will sound, the console will pause, and the time will flash in the display.

If the pedals do not move for several minutes, the console will turn off and the display will be reset.

HOW TO USE A PRESET WORKOUT

1. Turn on the console.

Press any button or begin pedaling to turn on the console.

2. Select a preset workout.

To select a preset workout, press the Workouts increase or decrease button repeatedly until the number of the desired workout appears in the right display.

When you select a preset workout, the duration of the workout will appear in the left display, the maximum resistance level for the workout will flash in the center display, and the number of the workout will appear in the right display.

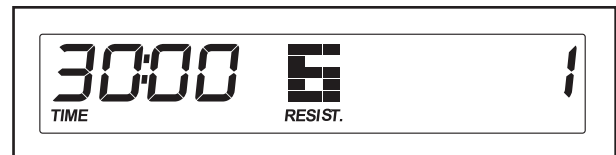

After a few seconds, a profile of the resistance levels of the workout will scroll across the center display.

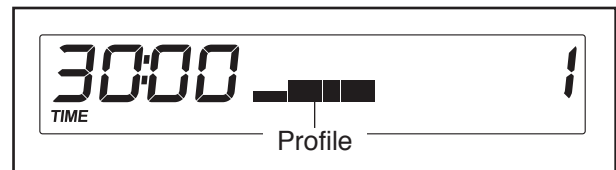

Note: Complete profiles of the preset workouts are printed on the sides of the console.

3. Begin pedaling to start the workout.

Each workout is divided into several one-minute segments. One resistance level is programmed for each segment. Note: The same resistance level may be programmed for consecutive segments.

During the workout, the workout profile will show your progress (see the drawing on page 18). The flashing segment of the profile represents the current segment of the workout. The height of the flashing segment indicates the resistance level for the current segment.

At the end of each segment of the workout, a series of tones will sound and the next segment of the profile will begin to flash. If a different resistance level is programmed for the next segment, the resistance level will flash in the display for a few seconds to alert you. The resistance of the pedals will then change.

If the resistance level for the current segment is too high or too low, you can manually override the setting by pressing the Resistance buttons. **IMPORTANT: When the current segment of the workout ends, the pedals will automatically adjust to the resistance level programmed for the next segment.**

If you stop pedaling for several seconds, a series of tones will sound and the workout will pause.

To restart the workout, simply resume pedaling. The workout will continue until the last segment of the profile flashes and the last segment of the workout ends.

Note: If you continue to pedal after the workout is completed, the display will continue to show exercise feedback; however, the display will not show the elapsed time until you select the manual mode or a new workout.

4. Follow your progress with the display.

See step 4 on page 17.

5. Measure your heart rate if desired.

See step 5 on page 18.

6. Turn on the fan if desired.

See step 6 on page 18.

7. When you are finished exercising, the console will turn off automatically.

See step 7 on page 18.

HOW TO USE AN IFIT WORKOUT

iFit cards are available separately. To purchase iFit cards, go to www.iFit.com or see the front cover of this manual. iFit cards are also available at select stores.

1. Turn on the console.

Press any button or begin pedaling to turn on the console.

2. Insert an iFit card and select a workout.

To use an iFit workout, insert an iFit card into the iFit slot; make sure that the iFit card is oriented so the metal contacts are face down and are facing the slot. When the iFit card is properly inserted, the indicator next to the slot will turn on.

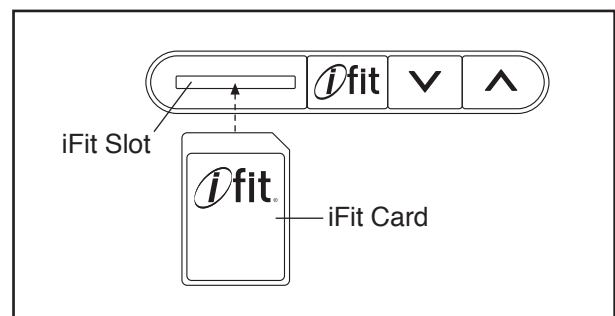

Next, select the desired workout on the iFit card by pressing the increase and decrease buttons next to the iFit slot.

The duration of the workout will appear in the left display, the maximum resistance level for the workout will flash in the center display, and the number of the workout will appear in the right display.

A moment after you select a workout, the voice of a personal trainer will begin guiding you through your workout. iFit workouts function in the same way as preset workouts. To use the workout, see steps 3 to 7 starting on page 18.

3. When you are finished exercising, remove the iFit card.

Remove the iFit card when you are finished exercising. Store the iFit card in a secure place.

HOW TO USE THE SOUND SYSTEM

To play music or audio books through the console sound system while you exercise, plug the included audio cable into the jack on the console and into a jack on your MP3 player or CD player; **make sure that the audio cable is fully plugged in.**

Next, press the Play button on your MP3 player or CD player. Adjust the volume level using the volume control on your MP3 player or CD player.

FCC INFORMATION

This equipment has been tested and found to comply with the limits for a Class B digital device, pursuant to part 15 of the FCC Rules. These limits are designed to provide reasonable protection against harmful interference in a residential installation. This equipment generates, uses, and can radiate radio frequency energy and, if not installed and used in accordance with the instructions, may cause harmful interference to radio communications. However, there is no guarantee that interference will not occur in a particular installation. If this equipment does cause harmful interference to radio or television reception, which can be determined by turning the equipment off and on, try to correct the interference by one or more of the following measures:

- Reorient or relocate the receiving antenna.
- Increase the separation between the equipment and the receiver.
- Connect the equipment into an outlet on a circuit different from that to which the receiver is connected.
- Consult the dealer or an experienced radio/TV technician for help.

FCC CAUTION: To assure continued compliance, use only shielded interface cables when connecting to computer or peripheral devices. Changes or modifications not expressly approved by the party responsible for compliance could void the user's authority to operate this equipment.

MAINTENANCE AND TROUBLESHOOTING

Inspect and tighten all parts of the elliptical regularly. Replace any worn parts immediately.

To clean the elliptical, use a damp cloth and a small amount of mild soap. **IMPORTANT: To avoid damage to the console, keep liquids away from the console and keep the console out of direct sunlight.**

CONSOLE TROUBLESHOOTING

Most console problems are the result of low batteries. See assembly step 6 on page 8 for replacement instructions.

If the console does not display your heart rate when you use the handgrip heart rate monitor, see step 5 on page 18.

HOW TO ADJUST THE REED SWITCH

If the console does not display correct feedback, the reed switch should be adjusted.

To adjust the reed switch, you must first remove the Shield Cover (37). Using a flat screwdriver, release the tabs along the sides of the Shield Cover, and then lift the Shield Cover away from the frame.

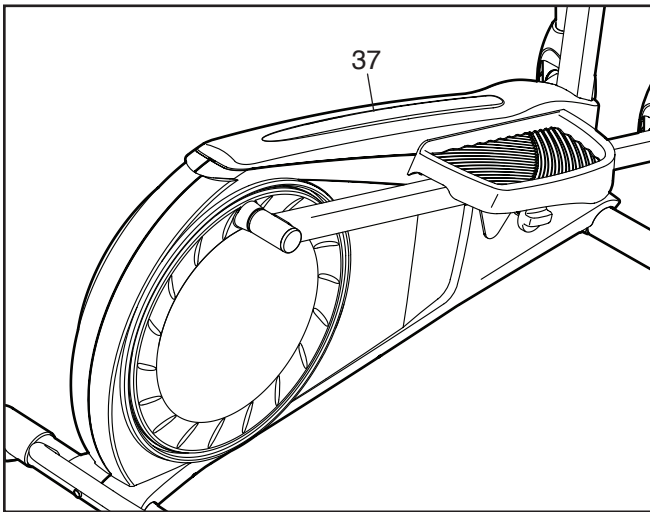

Note: For clarity, the right pedal disc is not shown in the drawing below. It is not necessary to remove the right pedal disc.

Locate the Reed Switch (58). Loosen, but do not remove, the M4 x 16mm Screw (92).

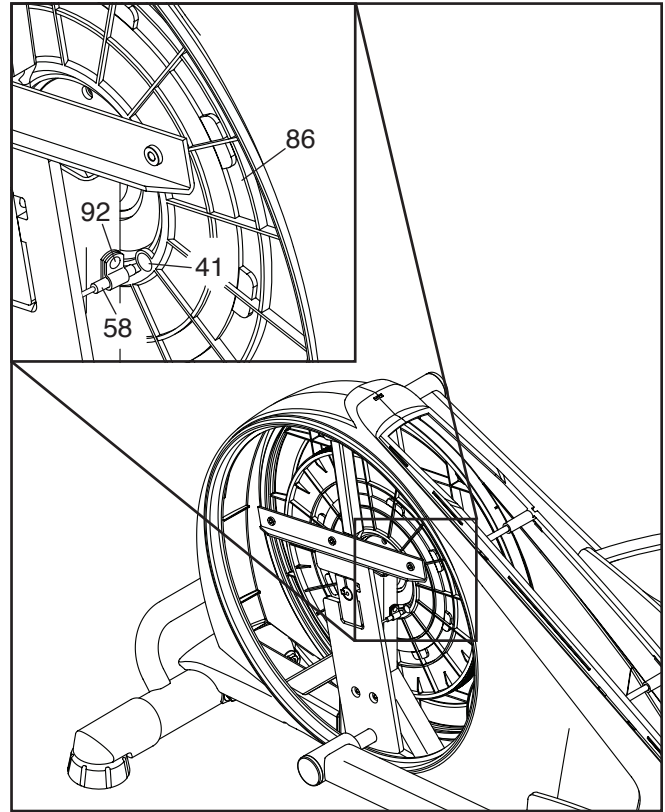

Next, rotate the Pulley (86) until a Magnet (41) is aligned with the Reed Switch (58). Slide the Reed Switch slightly toward or away from the Magnet. Then, retighten the M4 x 16mm Screw (92).

Rotate the Pulley (86) for a moment. Repeat these actions until the console displays correct feedback.

When the reed switch is correctly adjusted, reattach the shield cover.

HOW TO ADJUST THE DRIVE BELT

If you can feel the pedals slip while you are pedaling, even when the resistance is adjusted to the highest level, the drive belt may need to be adjusted.

To adjust the drive belt, you must remove the shield cover and the left shield (see the instructions below).

See EXPLODED DRAWING B on page 27. Using a flat screwdriver, release the tabs along the sides of the Shield Cover (37), and then lift the Shield Cover away from the frame.

Next, remove the M4 x 16mm Screws (92) and the M4 x 12mm Self-tapping Screws (97) from the Left and Right Shields (44, 45). **Make sure to note which size of Screw you remove from each hole.** Then, gently move the Left Shield out of the way.

Loosen the Pivot Screw (88). Then, tighten the Drive Belt Adjustment Screw (72) until the Drive Belt (46) is tight.

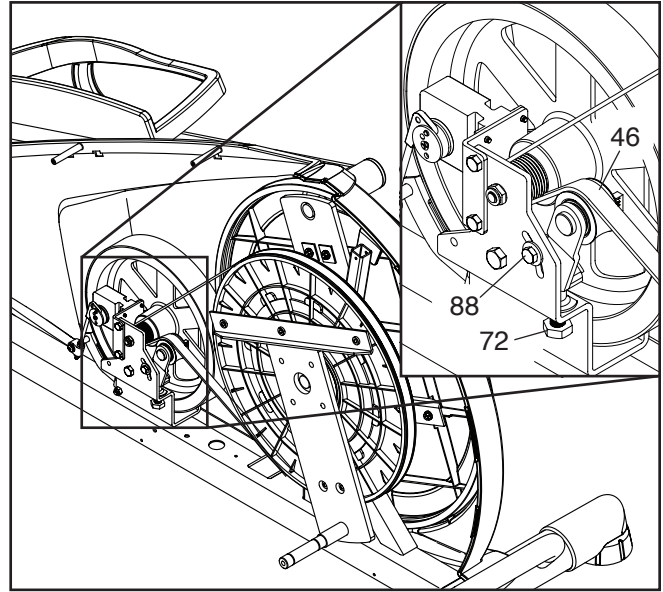

When the Drive Belt (46) is tight, tighten the Pivot Screw (88).

Then, reattach the left shield and the shield cover.

EXERCISE GUIDELINES

⚠️ WARNING: Before beginning this or any exercise program, consult your physician. This is especially important for persons over age 35 or persons with pre-existing health problems.

The heart rate monitor is not a medical device. Various factors may affect the accuracy of heart rate readings. The heart rate monitor is intended only as an exercise aid in determining heart rate trends in general.

These guidelines will help you to plan your exercise program. For detailed exercise information, obtain a reputable book or consult your physician. Remember, proper nutrition and adequate rest are essential for successful results.

EXERCISE INTENSITY

Whether your goal is to burn fat or to strengthen your cardiovascular system, exercising at the proper intensity is the key to achieving results. You can use your heart rate as a guide to find the proper intensity level. The chart below shows recommended heart rates for fat burning and aerobic exercise.

165	155	145	140	130	125	115	♥
145	138	130	125	118	110	103	♥
125	120	115	110	105	95	90	♥
<hr/>							
20	30	40	50	60	70	80	

To find the proper intensity level, find your age at the bottom of the chart (ages are rounded off to the nearest ten years). The three numbers listed above your age define your “training zone.” The lowest number is the heart rate for fat burning, the middle number is the heart rate for maximum fat burning, and the highest number is the heart rate for aerobic exercise.

Burning Fat—To burn fat effectively, you must exercise at a low intensity level for a sustained period of time. During the first few minutes of exercise, your body uses carbohydrate calories for energy. Only after the first few minutes of exercise does your body begin to use stored fat calories for energy. If your goal is to burn fat, adjust the intensity of your exercise until your heart rate is near the lowest number in your training zone. For maximum fat burning, exercise with your heart rate near the middle number in your training zone.

Aerobic Exercise—If your goal is to strengthen your cardiovascular system, you must perform aerobic exercise, which is activity that requires large amounts of oxygen for prolonged periods of time. For aerobic exercise, adjust the intensity of your exercise until your heart rate is near the highest number in your training zone.

WORKOUT GUIDELINES

Warming Up—Start with 5 to 10 minutes of stretching and light exercise. A warm-up increases your body temperature, heart rate, and circulation in preparation for exercise.

Training Zone Exercise—Exercise for 20 to 30 minutes with your heart rate in your training zone. (During the first few weeks of your exercise program, do not keep your heart rate in your training zone for longer than 20 minutes.) Breathe regularly and deeply as you exercise—never hold your breath.

Cooling Down—Finish with 5 to 10 minutes of stretching. Stretching increases the flexibility of your muscles and helps to prevent post-exercise problems.

EXERCISE FREQUENCY

To maintain or improve your condition, complete three workouts each week, with at least one day of rest between workouts. After a few months of regular exercise, you may complete up to five workouts each week, if desired. Remember, the key to success is to make exercise a regular and enjoyable part of your everyday life.

PART LIST

Model No. PFEL04211.0 R0112A

Key No.	Qty.	Description	Key No.	Qty.	Description
1	1	Frame	46	1	Drive Belt
2	1	Upright	47	2	Leveling Foot
3	1	Rear Upright Cover	48	2	Stabilizer Cap
4	1	Console	49	1	Right Pedal Arm
5	1	Accessory Tray	50	2	Wheel
6	2	Upper Body Leg	51	1	Flywheel
7	1	Resistance Wheel	52	1	Idler
8	1	Left Upper Body Arm	53	1	C-magnet
9	1	Right Upper Body Arm	54	1	Resistance Motor
10	2	Foam Grip	55	1	Motor Bracket
11	2	Upper Body Arm Cap	56	1	Adjustment Arm
12	1	Left Pedal	57	1	Reed Switch Clamp
13	1	Right Pedal	58	1	Reed Switch/Wire
14	1	Left Pedal Arm	59	4	M8 x 10mm Screw
15	1	Left Pedal Bracket	60	1	Key
16	1	Front Upright Cover	61	1	M8 Locknut
17	4	Pivot Bushing	62	1	M6 x 16mm Screw
18	10	Pedal Disc Mount	63	2	Shoulder Screw
19	2	Pivot Cover A	64	1	Flywheel Axle
20	2	Front Leg Cover	65	1	C-magnet Bolt
21	2	Rear Leg Cover	66	1	Idler Bolt
22	2	Pivot Cover B	67	1	Key Screw
23	4	Pedal Arm Bushing	68	1	Crank Arm Bolt
24	1	Crank	69	4	Resistance Motor Bolt
25	1	Right Crank Arm	70	1	Rear Stabilizer
26	2	Pedal Disc	71	2	Motor Bracket Screw
27	1	Crank Arm Spacer	72	1	Drive Belt Adjustment Screw
28	2	Sensor Wire	73	1	Front Stabilizer
29	4	Bearing	74	1	M6 Locknut
30	2	Pedal Arm Cap	75	2	Cam Axle
31	2	Bolt Set	76	4	M8 x 45mm Button Bolt
32	1	Console Cover	77	6	M8 Jam Nut
33	6	M8 Washer	78	5	M10 Split Washer
34	1	Adjustment Block	79	8	M10 x 20mm Screw
35	1	M5 Washer	80	4	M8 x 20mm Screw
36	1	Small Snap Ring	81	2	Pedal Knob
37	1	Shield Cover	82	4	M10 x 85mm Screw
38	2	Crank Bearing	83	1	M5 x 7mm Screw
39	1	Handlebar	84	8	#10 x 16mm Screw
40	2	Large Snap Ring	85	2	M8 x 18mm Screw
41	2	Magnet	86	1	Pulley
42	1	Main Wire	87	1	M3.5 x 12mm Screw
43	2	M6 Washer	88	1	Pivot Screw
44	1	Left Shield	89	4	M8 x 15mm Screw
45	1	Right Shield	90	1	M4 x 16mm Ground Screw

Key No.	Qty.	Description	Key No.	Qty.	Description
91	2	Adjustment Nut	100	2	M10 x 104mm Screw
92	18	M4 x 16mm Screw	101	2	Pedal Bracket Spring
93	2	Sensor	102	1	Right Pedal Bracket
94	1	Flywheel Bearing	103	2	M4 x 48mm Screw
95	1	Audio Cable	104	2	Short Bumper
96	1	Left Crank Arm	105	2	Long Bumper
97	2	M4 x 12mm Self-tapping Screw	*	–	User's Manual
98	4	Cam Axle Bushing	*	–	Assembly Tool
99	2	M4 x 16mm Machine Screw	*	–	Grease Packet

Note: Specifications are subject to change without notice. For information about ordering replacement parts, see the back cover of this manual. *These parts are not illustrated.

EXPLODED DRAWING A

Model No. PFEL04211.0 R0112A

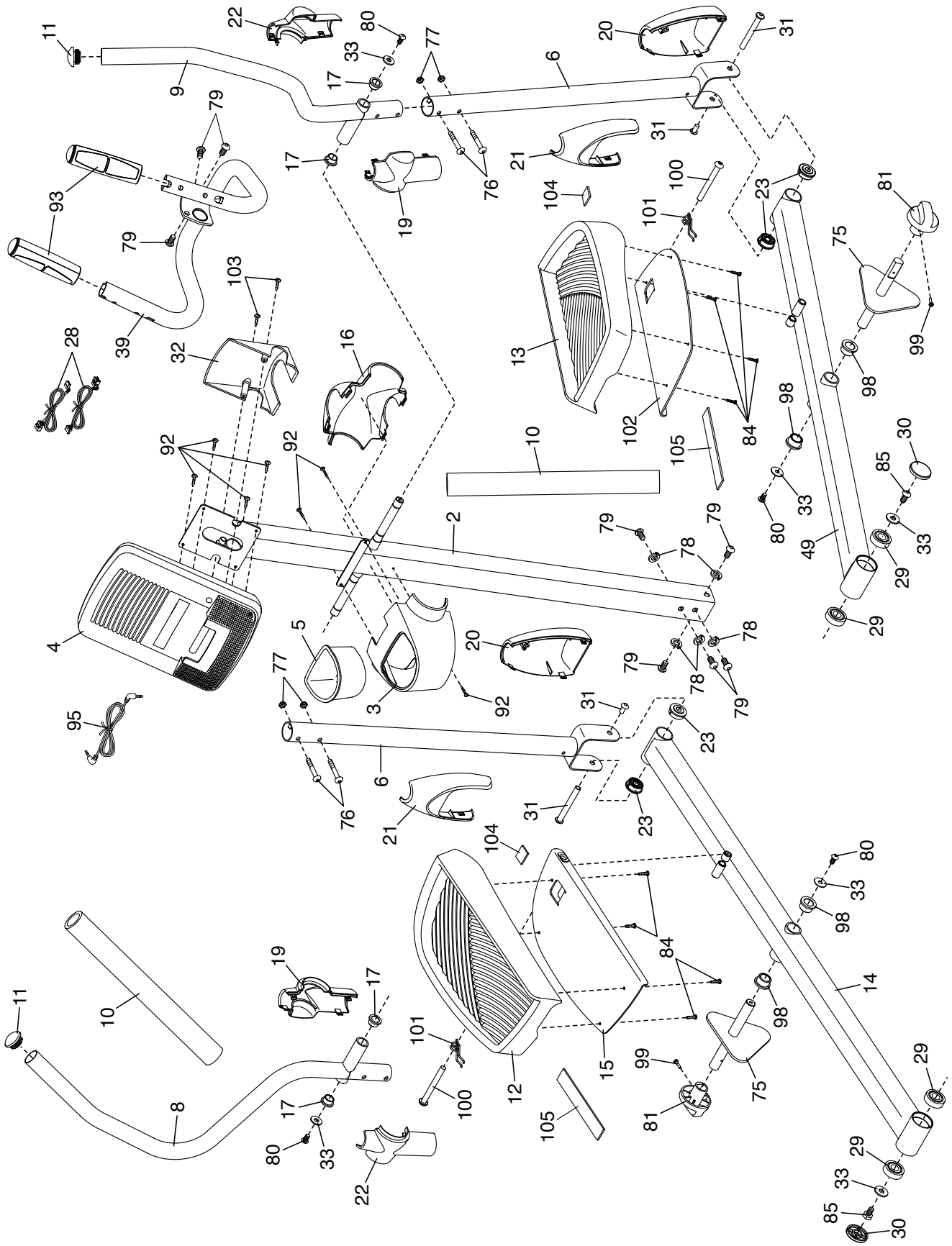

EXPLODED DRAWING B

Model No. PFEL04211.0 R0112A

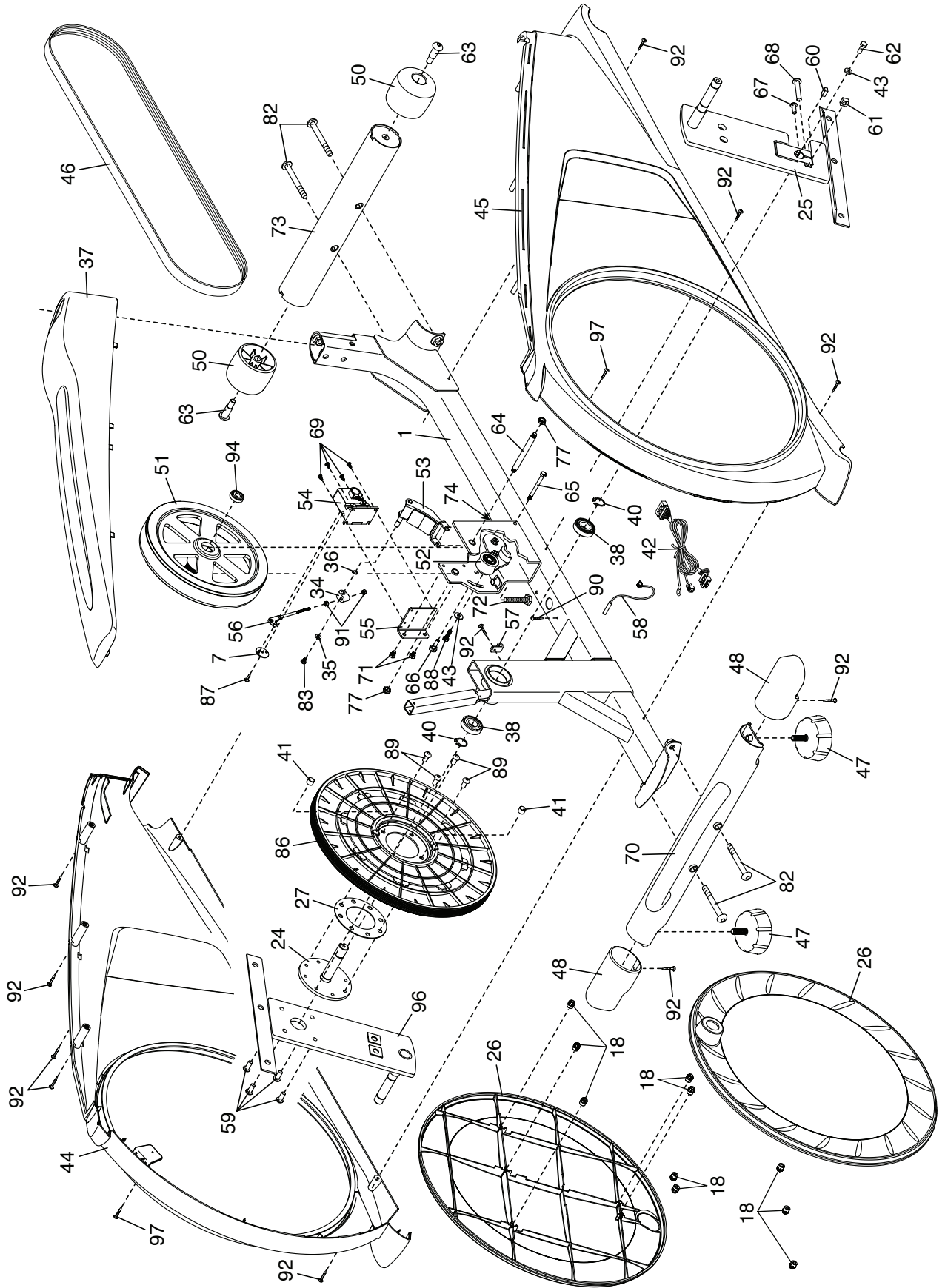

ORDERING REPLACEMENT PARTS

To order replacement parts, please see the front cover of this manual. To help us assist you, be prepared to provide the following information when contacting us:

- the model number and serial number of the product (see the front cover of this manual)
- the name of the product (see the front cover of this manual)
- the key number and description of the replacement part(s) (see the PART LIST and the EXPLODED DRAWING near the end of this manual)

LIMITED WARRANTY

IMPORTANT: You must register this product within 30 days of the purchase date to avoid added fees for service needed under warranty. Go to www.proform.com/registration.

ICON Health & Fitness, Inc. (ICON) warrants this product to be free from defects in workmanship and material, under normal use and service conditions. The frame is warranted for five (5) years from the date of purchase. Parts and labor are warranted for ninety (90) days from the date of purchase.

This warranty extends only to the original purchaser (customer). ICON's obligation under this warranty is limited to repairing or replacing, at ICON's option, the product through one of its authorized service centers. All repairs for which warranty claims are made must be preauthorized by ICON. If the product is shipped to a service center, freight charges to and from the service center will be the customer's responsibility. If replacement parts are shipped while the product is under warranty, the customer will be responsible for a minimal handling charge. For in-home service, the customer will be responsible for a minimal trip charge. This warranty does not extend to freight damage to the product. This warranty will automatically be voided if the product is used as a store display model, if the product is purchased or transported outside the USA, if all instructions in this manual are not followed, if the product is abused or improperly or abnormally used, or if the product is used for commercial or rental purposes. No other warranty beyond that specifically set forth above is authorized by ICON.

ICON is not responsible or liable for indirect, special, or consequential damages arising out of or in connection with the use or performance of the product; damages with respect to any economic loss, loss of property, loss of revenues or profits, loss of enjoyment or use, or costs of removal or installation; or other consequential damages of any kind. Some states do not allow the exclusion or limitation of incidental or consequential damages. Accordingly, the above limitation may not apply to the customer.

The warranty extended hereunder is in lieu of any and all other warranties, and any implied warranties of merchantability or fitness for a particular purpose are limited in their scope and duration to the terms set forth herein. Some states do not allow limitations on how long an implied warranty lasts. Accordingly, the above limitation may not apply to the customer.

This warranty provides specific legal rights; the customer may have other rights that vary from state to state.

ICON Health & Fitness, Inc., 1500 S. 1000 W., Logan, UT 84321-9813