

PRO-FORM[®]

14.0 CE

www.proform.com

Model No. PFEL18010.0

Serial No. _____

Write the serial number in the space above for reference.

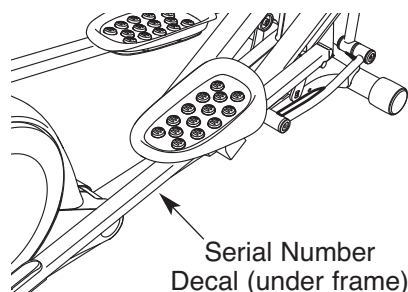

USER'S MANUAL

QUESTIONS?

If you have questions, or if parts are damaged or missing, **DO NOT CONTACT THE STORE**; please contact Customer Care.

IMPORTANT: Please register this product (see the limited warranty on the back cover of this manual) before contacting Customer Care.

CALL TOLL-FREE:

1-888-533-1333

Mon.–Fri., 6 a.m.–6 p.m. MT

Sat. 8 a.m.–4 p.m. MT

ON THE WEB:

www.proformservice.com

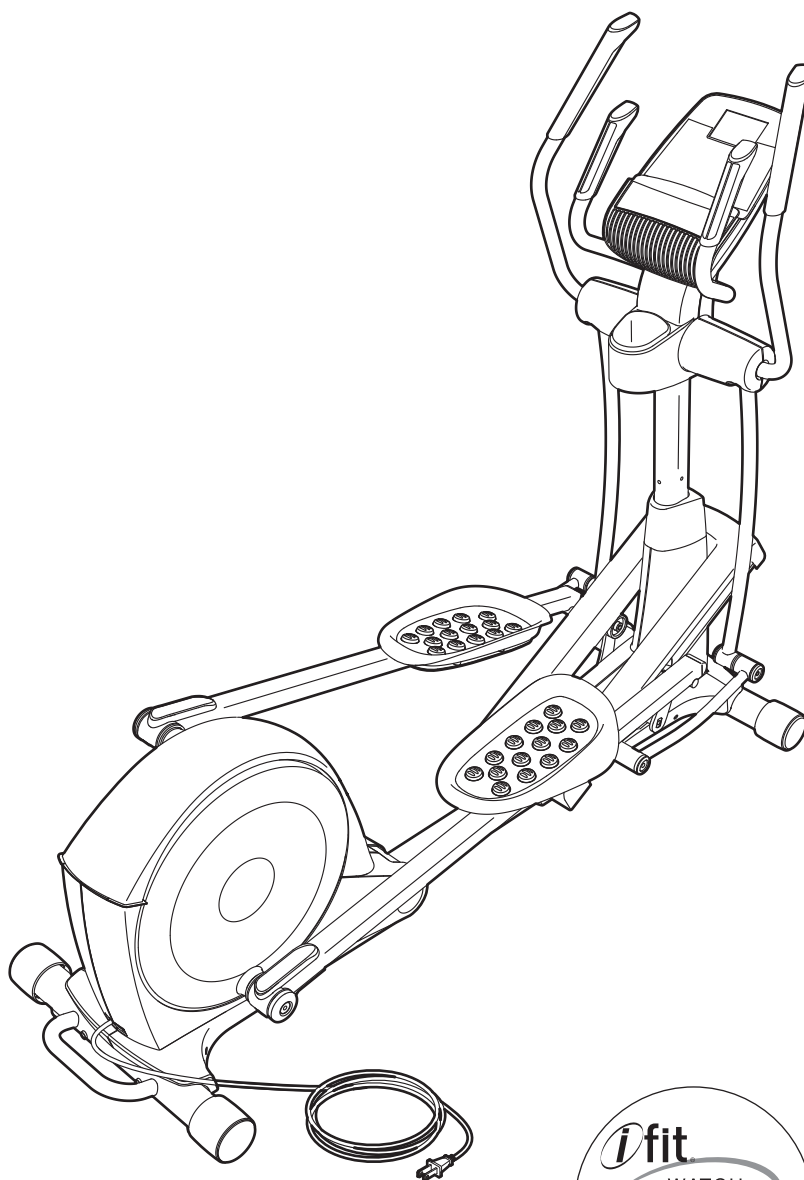

CAUTION

Read all precautions and instructions in this manual before using this equipment. Keep this manual for future reference.



TABLE OF CONTENTS

WARNING DECAL PLACEMENT2

IMPORTANT PRECAUTIONS3

BEFORE YOU BEGIN4

ASSEMBLY5

HOW TO USE THE ELLIPTICAL14

MAINTENANCE AND TROUBLESHOOTING23

EXERCISE GUIDELINES25

PART LIST27

EXPLODED DRAWING29

ORDERING REPLACEMENT PARTSBack Cover

LIMITED WARRANTYBack Cover

WARNING DECAL PLACEMENT

This drawing shows the location(s) of the warning decal(s). **If a decal is missing or illegible, see the front cover of this manual and request a free replacement decal. Apply the decal in the location shown.** Note: The decal(s) may not be shown at actual size.

WARNING

- Misuse of this machine may result in serious injury.
- Read user's manual prior to use and follow all warnings and instructions.
- Do not allow children on or around machine.
- Pedals continue to spin when you stop pedaling.
- Spinning pedals can cause injury.
- Reduce pedal speed in a controlled manner.
- User weight must not exceed 300 pounds.
- Replace label if damaged, illegible, or removed.

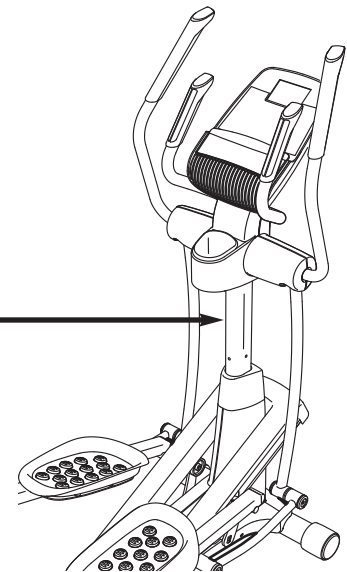
IMPORTANT PRECAUTIONS

⚠️ WARNING: To reduce the risk of serious injury, read all important precautions and instructions in this manual and all warnings on your elliptical before using your elliptical. ICON assumes no responsibility for personal injury or property damage sustained by or through the use of this product.

1. Before beginning any exercise program, consult your physician. This is especially important for persons over age 35 or persons with pre-existing health problems.
2. Use the elliptical only as described in this manual.
3. It is the responsibility of the owner to ensure that all users of the elliptical are adequately informed of all precautions.
4. The elliptical is intended for home use only. Do not use the elliptical in a commercial, rental, or institutional setting.
5. Keep the elliptical indoors, away from moisture and dust. Do not put the elliptical in a garage or covered patio, or near water.
6. Place the elliptical on a level surface, with at least 3 ft. (0.9 m) of clearance in the front and rear of the elliptical and 2 ft. (0.6 m) on each side. To protect the floor or carpet from damage, place a mat under the elliptical.
7. Inspect and properly tighten all parts regularly. Replace any worn parts immediately.
8. Keep children under age 12 and pets away from the elliptical at all times.
9. The elliptical should not be used by persons weighing more than 300 lbs. (136 kg).
10. Wear appropriate clothes while exercising; do not wear loose clothes that could become caught on the elliptical. Always wear athletic shoes for foot protection while exercising.
11. Hold the handlebars or the upper body arms when mounting, dismounting, or using the elliptical.
12. The pulse sensor is not a medical device. Various factors may affect the accuracy of heart rate readings. The pulse sensor is intended only as an exercise aid in determining heart rate trends in general.
13. The elliptical does not have a freewheel; the pedals will continue to move until the flywheel stops. Reduce your pedaling speed in a controlled way.
14. Keep your back straight while using the elliptical; do not arch your back.
15. Over exercising may result in serious injury or death. If you feel faint or if you experience pain while exercising, stop immediately and cool down.

BEFORE YOU BEGIN

Thank you for selecting the revolutionary PROFORM® 14.0 CE elliptical. The 14.0 CE elliptical provides an impressive selection of features designed to make your workouts at home more effective and enjoyable.

For your benefit, read this manual carefully before you use the elliptical. If you have questions after reading this manual, please see the front cover of this

manual. To help us assist you, note the product model number and serial number before contacting us. The model number and the location of the serial number decal are shown on the front cover of this manual.

Before reading further, please familiarize yourself with the parts that are labeled in the drawing below.

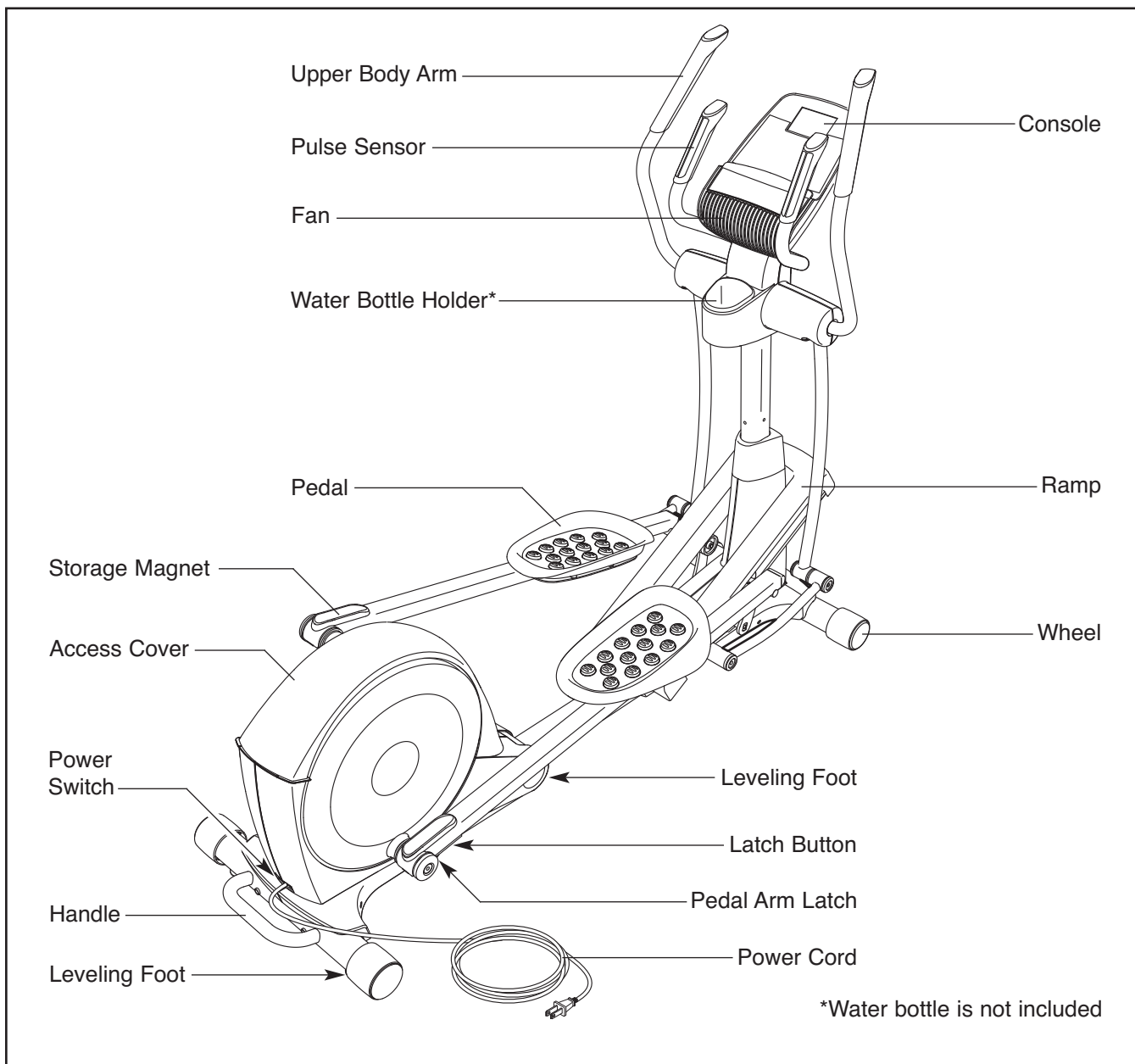

ASSEMBLY

Assembly requires two persons. Place all parts of the elliptical in a cleared area and remove the packing materials. Do not dispose of the packing materials until assembly is completed.

In addition to the included tool(s) and grease packet(s), assembly requires a Phillips screwdriver  and a rubber mallet .

See the drawings below to identify the small parts needed for assembly. The number in parentheses below each drawing is the key number of the part, from the PART LIST near the end of this manual. The number following the key number is the quantity needed for assembly. **Note: If a part is not in the hardware kit, check to see if it has been preassembled. To avoid damaging parts, do not use power tools for assembly.**

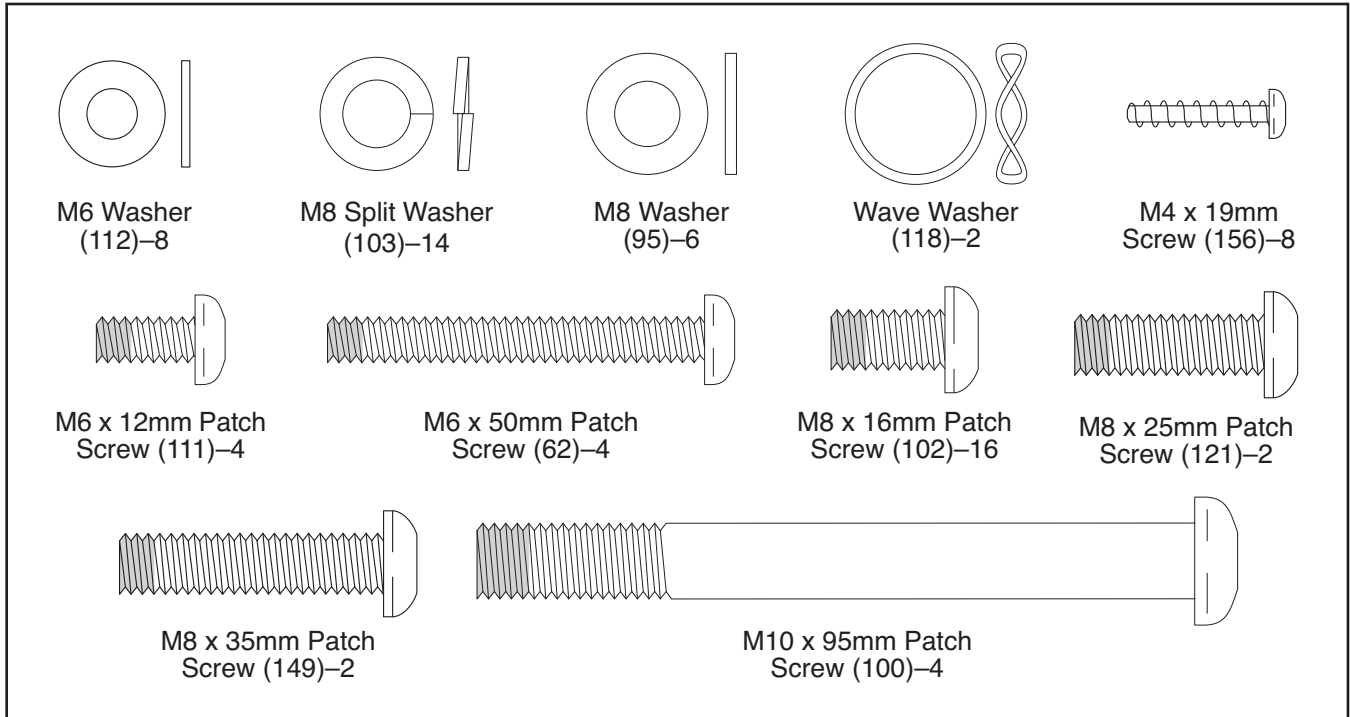

1.

To make assembly easier, read the information on page 5 before you begin.

Orient the Rear Stabilizer (4) as shown.

Attach the Rear Stabilizer (4) to the Folding Frame (2) with two M10 x 95mm Patch Screws (100).

Next, hold the handle on the Rear Stabilizer (4), press the Latch Button (67), and lower the Rear Stabilizer and the Folding Frame (2) to the floor.

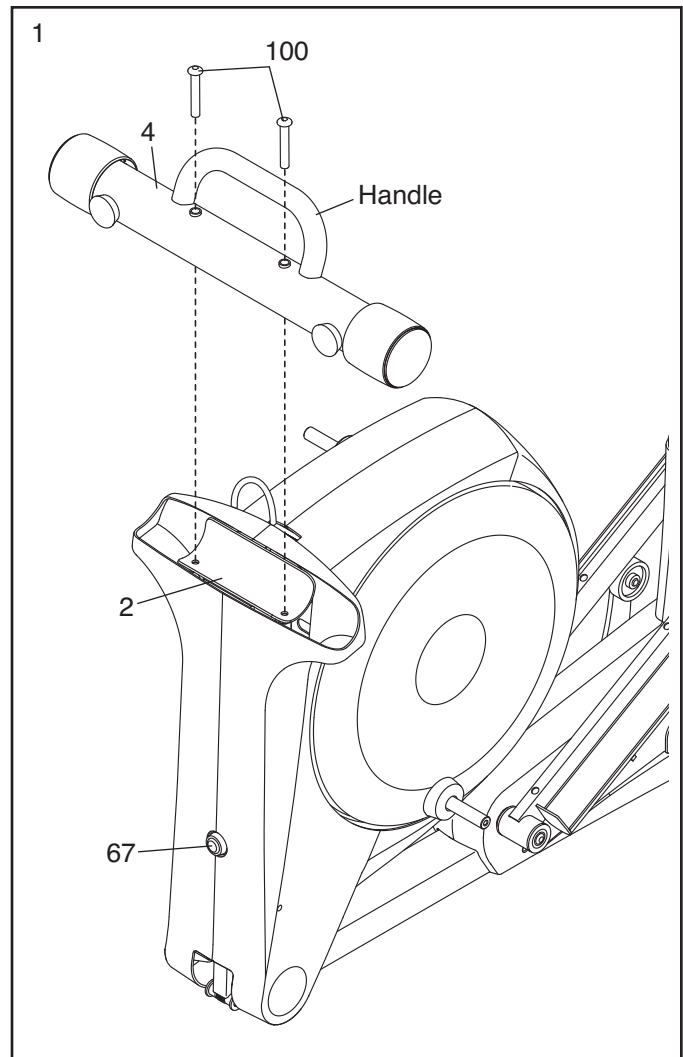

2. Orient the Front Stabilizer (3) so that the indicated hole is facing the pin on the Main Frame (1).

While a second person lifts the front of the Main Frame (1), attach the Front Stabilizer (3) with two M10 x 95mm Patch Screws (100).

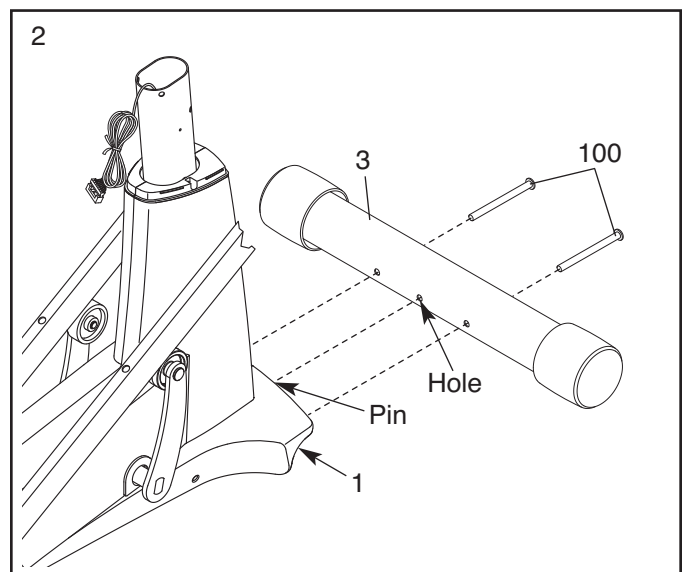

3. **See drawing 3a.** Identify and orient the Upright (5) and the Top Cover (27) as shown.

Slide the Top Cover (27) upward onto the Upright (5).

Have a second person hold the Upright (5) and the Top Cover (27) near the Main Frame (1).

Locate the wire tie in the Upright (5). Tie the lower end of the wire tie to the Wire Harness (60). Next, pull the upper end of the wire tie until the Wire Harness is routed through the Upright.

Tip: To prevent the Wire Harness (60) from falling into the Upright (5), secure the Wire Harness with the wire tie.

See drawing 3b. Tip: Avoid pinching the Wire Harness (60). Insert the Upright (5) into the Main Frame (1).

Attach the Upright (5) with four M8 x 16mm Patch Screws (102) and four M8 Split Washers (103); **do not tighten the Patch Screws yet.** You will tighten the Patch Screws at the end of step 10.

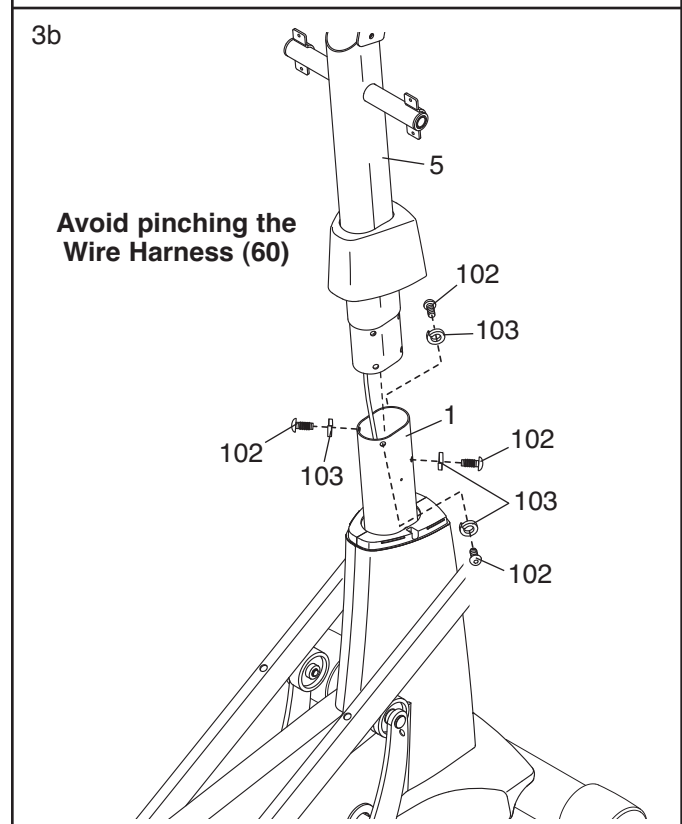
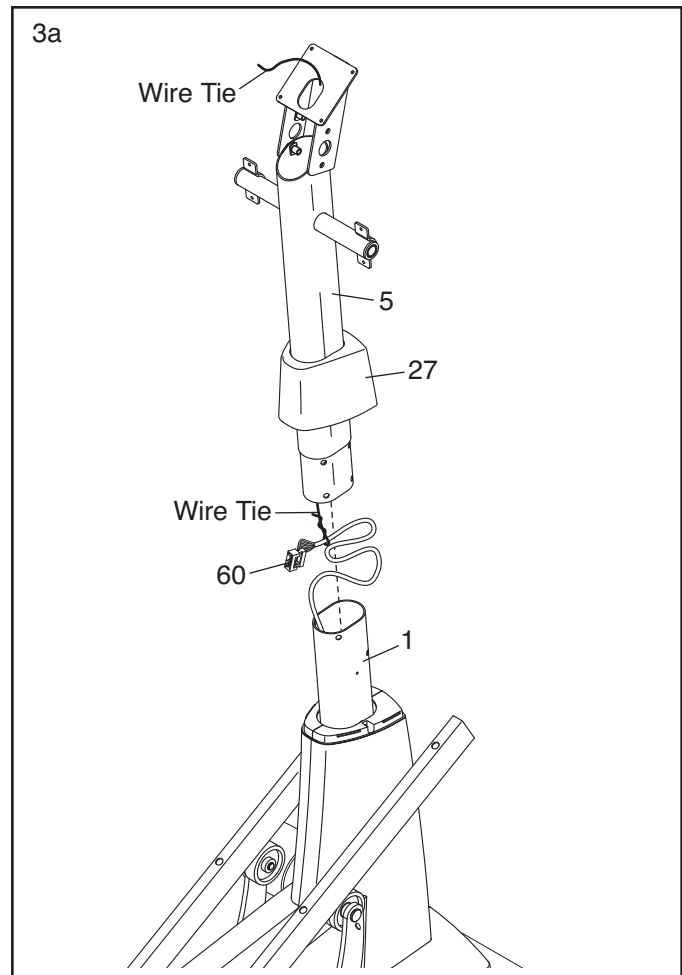

- Using a small plastic bag to keep your fingers clean, apply a coat of the included grease to the Upright Axle (48) and to two Wave Washers (118).

Tip: Avoid damaging the Wire Harness (60). Insert the Upright Axle (48) through the Upright (5) and center it. Slide a Wave Washer (118) onto each side of the Upright Axle.

Next, identify the Right and Left Upper Body Legs (6, 7), which are marked with “Right” and “Left” stickers, and orient them as shown.

Slide the Right and Left Upper Body Legs (6, 7) onto the right and left sides of the Upright Axle (48).

Tighten an M8 x 16mm Patch Screw (102) and an M8 Washer (95) into each end of the Upright Axle (48) at the same time.

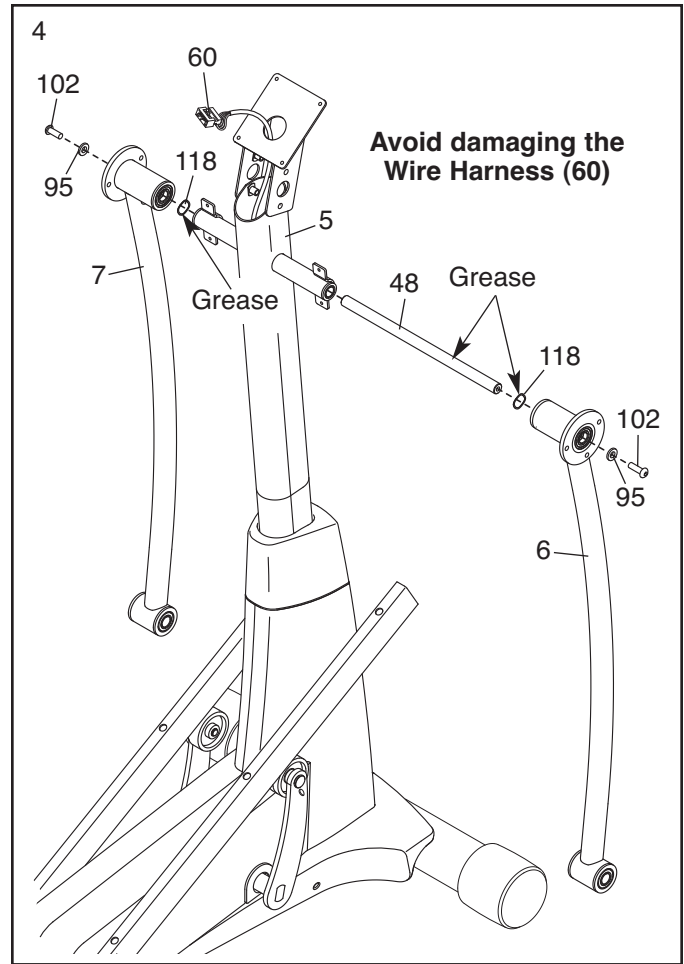

- Identify the Right Pedal (14), the Right Gel Pad (151), and the Right Pedal Arm (12) assembly, which are marked with “Right” stickers, and orient them as shown.

Set the Right Gel Pad (151) on the Right Pedal Arm (12). Then, set the Right Pedal (14) on the Right Gel Pad.

Attach the Right Pedal (14) to the Right Pedal Arm (12) with two M6 x 12mm Patch Screws (111) and two M6 Washers (112); **do not tighten the Patch Screws yet.**

Next, tighten two M6 x 50mm Patch Screws (62) with two M6 Washers (112) into the Right Pedal Arm (12) and the Right Pedal (14). **Then, tighten the two M6 x 12mm Patch Screws (111).**

Attach the Left Pedal (not shown) to the Left Pedal Arm (not shown) assembly in the same way.

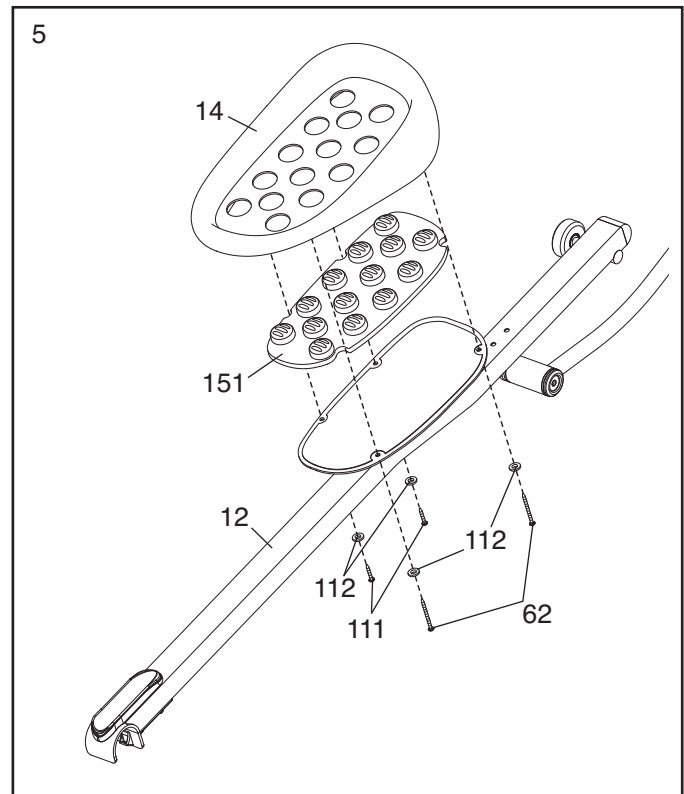

6. Apply grease to the axle on the right Crank Arm (39).

Orient a Pedal Arm Sleeve (46) so that the flat side is facing the elliptical. Slide the Pedal Arm Sleeve onto the axle on the right Crank Arm (39).

Attach the Pedal Arm Sleeve (46) with an M8 x 25mm Patch Screw (121), a Large Axle Cover (113), and an M8 Washer (95). **Tip: Avoid damaging the Large Axle Cover when tightening the Patch Screw.**

Repeat this step on the other side of the elliptical.

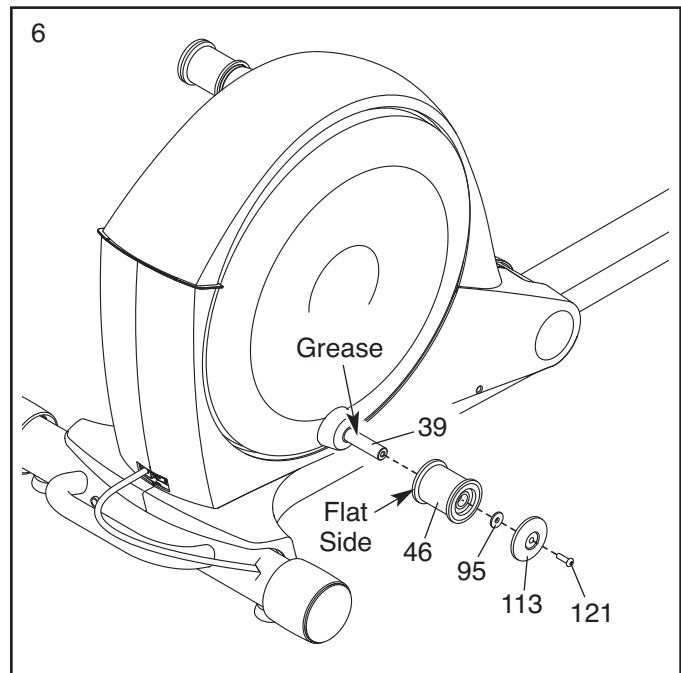

7. **See drawing 7a.** Locate the Pedal Arm Roller (32) on the Right Pedal Arm (12).

Set the Pedal Arm Roller (32) on the right side of the Ramp (130).

See drawing 7b. Pull upward on the Latch (50) on the Right Pedal Arm (12).

Press the Right Pedal Arm (12) onto the right Pedal Arm Sleeve (46). **Make sure that the Right Pedal Arm latches into place.**

Repeat this step on the other side of the elliptical.

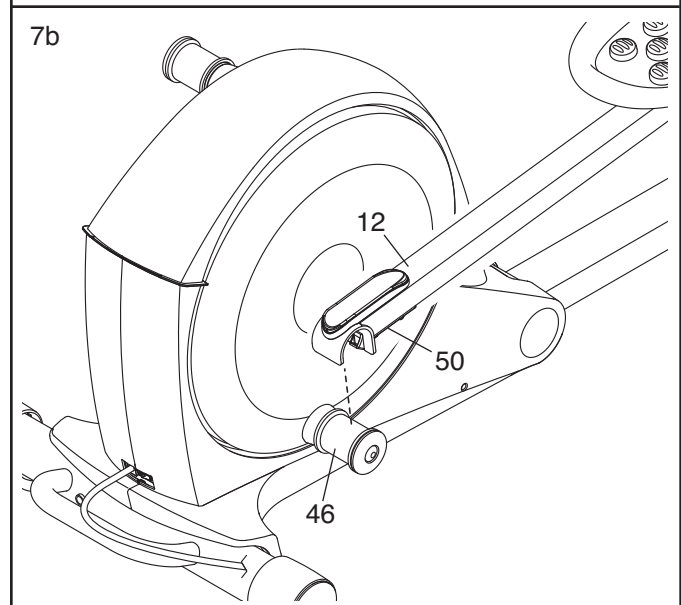
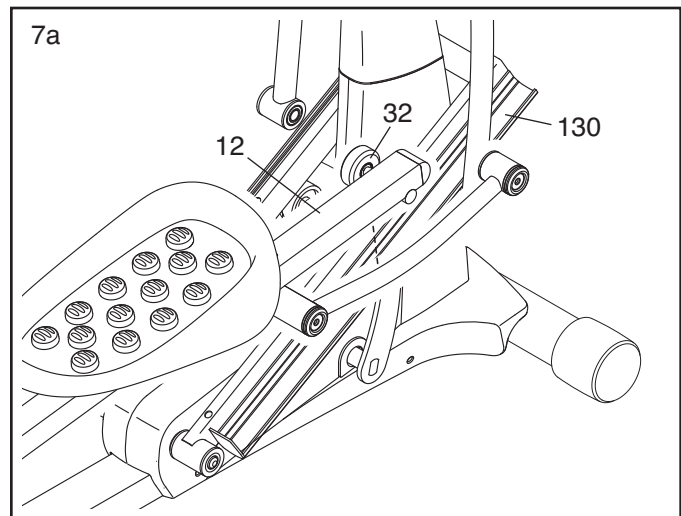

8. Orient the Ramp Cover (131) around the Upright (5) as shown.

Press the tabs on the Ramp Cover (131) into the Ramp (130).

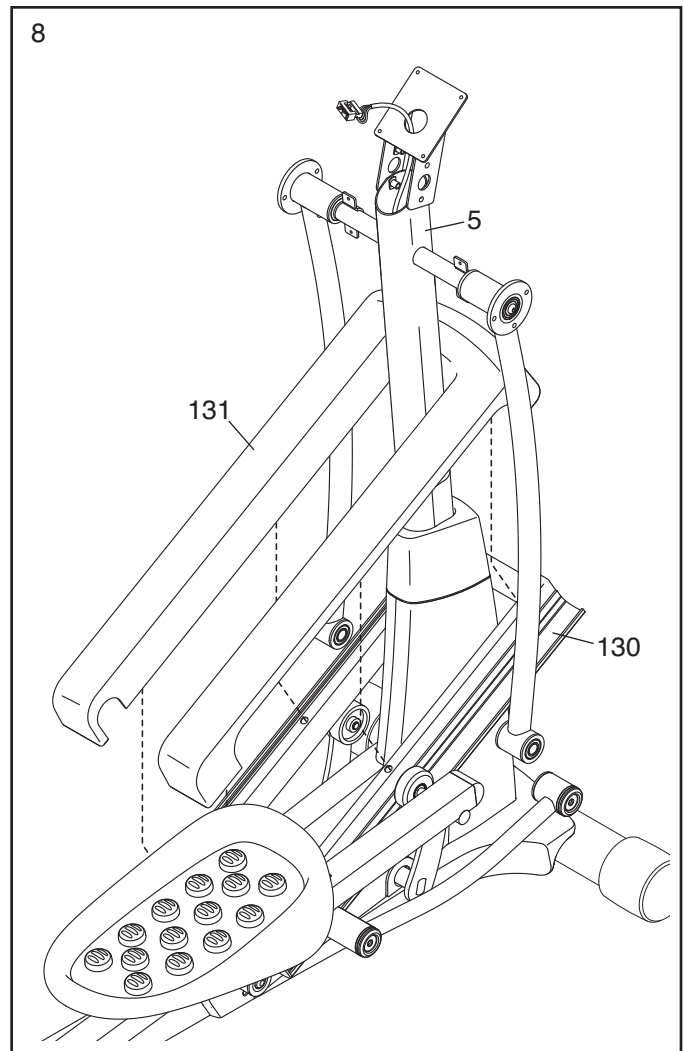

9. Apply grease to a Link Arm Axle (114).

Insert the Link Arm Axle (114) into the Right Upper Body Leg (6) and the Right Link Arm (43) from the side shown.

Insert a hex key into the M8 x 35mm Patch Screw (149) in the Link Arm Axle (114).

Using a second hex key, tighten another M8 x 35mm Patch Screw (149), a Small Axle Cover (56), and an M8 Washer (95) into the other end of the Link Arm Axle (114). **Tip: Avoid damaging the Small Axle Cover when tightening the Patch Screw.**

Repeat this step on the other side of the elliptical.

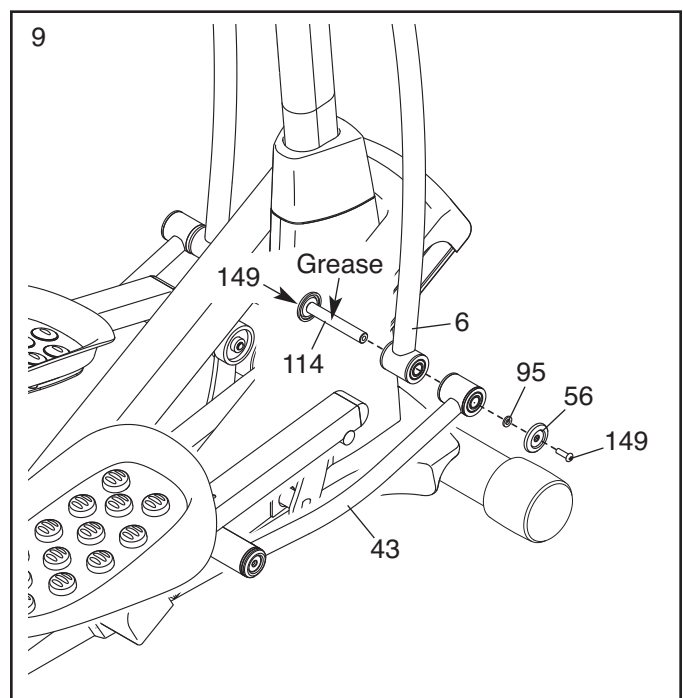

10. Identify the Right Upper Body Arm (8), which is marked with a “Right” sticker, and orient it as shown.

Have a second person hold the Right Upper Body Arm (8) near the Right Upper Body Leg (6).

Attach the Right Upper Body Arm (8) to the Right Upper Body Leg (6) with three M8 x 16mm Patch Screws (102) and three M8 Split Washers (103).

Attach the Left Upper Body Arm (9) to the Left Upper Body Leg (7) in the same way.

See step 3 on page 7. Tighten the M8 x 16mm Patch Screws (102).

Slide the Top Cover (27) downward and press it into the Right and Left Frame Covers (21, 22).

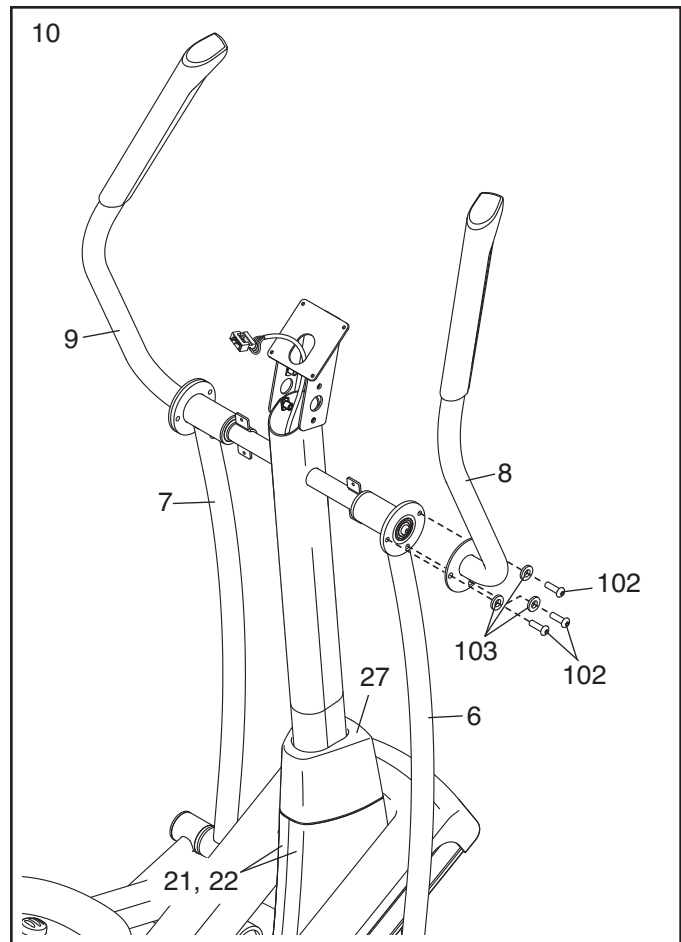

11. Identify the Right Handlebar (10), which is marked with a “Right” sticker, and orient it as shown.

Have a second person hold the Right Handlebar (10) near the right side of the Upright (5).

Insert the Pulse Wire (105) from the Right Handlebar (10) into the right side of the Upright (5) and pull it upward out of the top of the Upright.

Tip: Avoid pinching the Pulse Wire (105).

Attach the Right Handlebar (10) to the Upright (5) with two M8 x 16mm Patch Screws (102) and two M8 Split Washers (103).

Attach the Left Handlebar (11) in the same way.

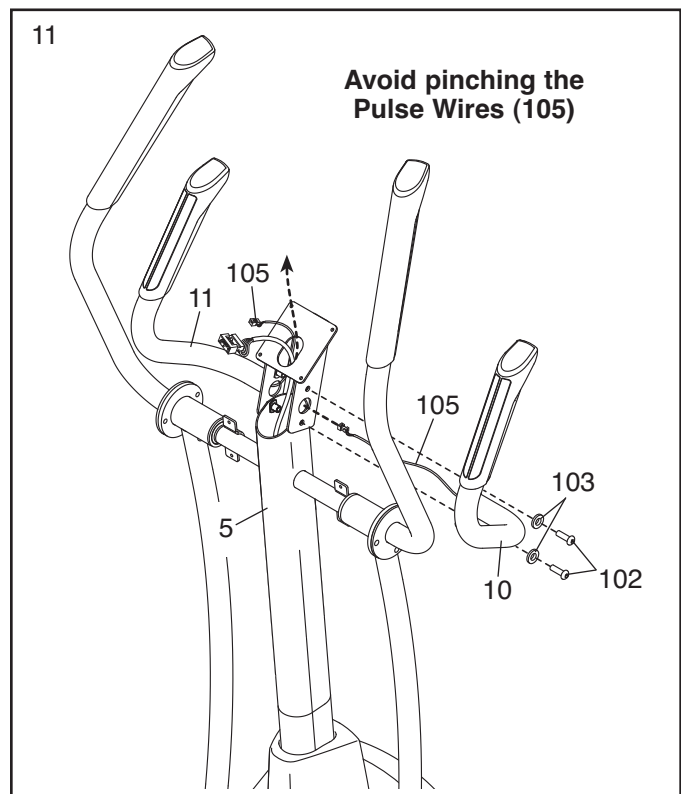

12. Orient the Rear Upright Cover (25) as shown.

Attach the Rear Upright Cover (25) to the Upright (5) with four M4 x 19mm Screws (156).

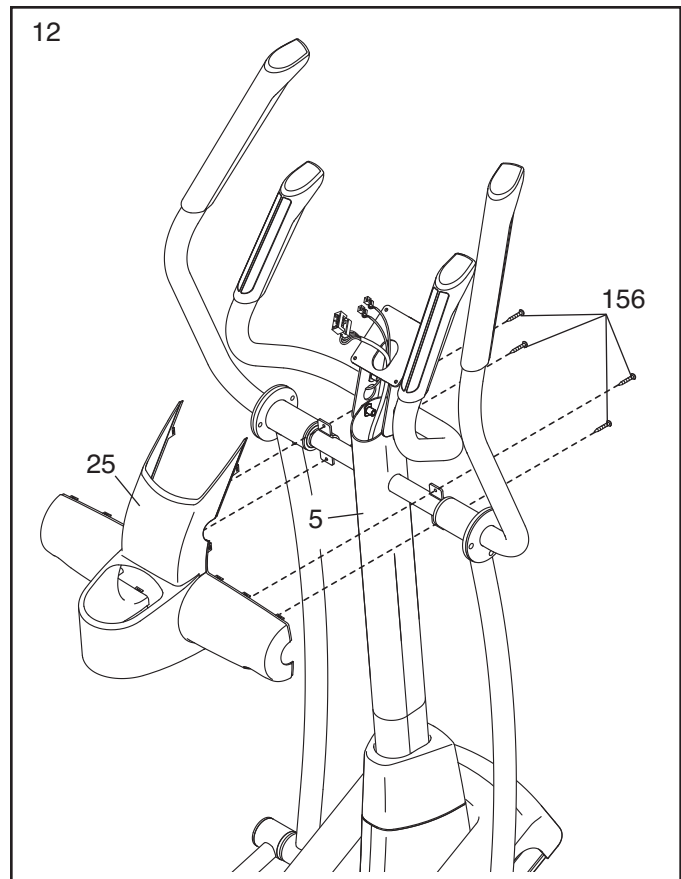

13. Untie and discard the wire tie attached to the Wire Harness (60).

While a second person holds the Console (33) near the Upright (5), connect the wires on the Console to the Wire Harness (60) and to the Pulse Wires (105).

Insert the excess wire downward into the Upright (5) or upward into the Console (33).

Tip: Avoid pinching the wires. Attach the Console (33) to the Upright (5) with four M4 x 19mm Screws (156).

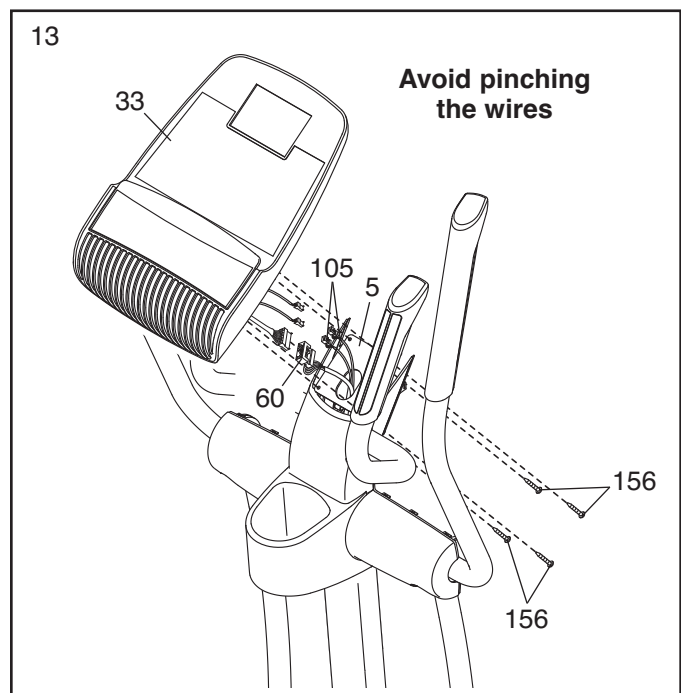

14. Orient the Front Upright Cover (24) as shown.

Attach the Front Upright Cover (24) around the Upright (5) by pressing the tabs on the Front Upright Cover into the Rear Upright Cover (25).

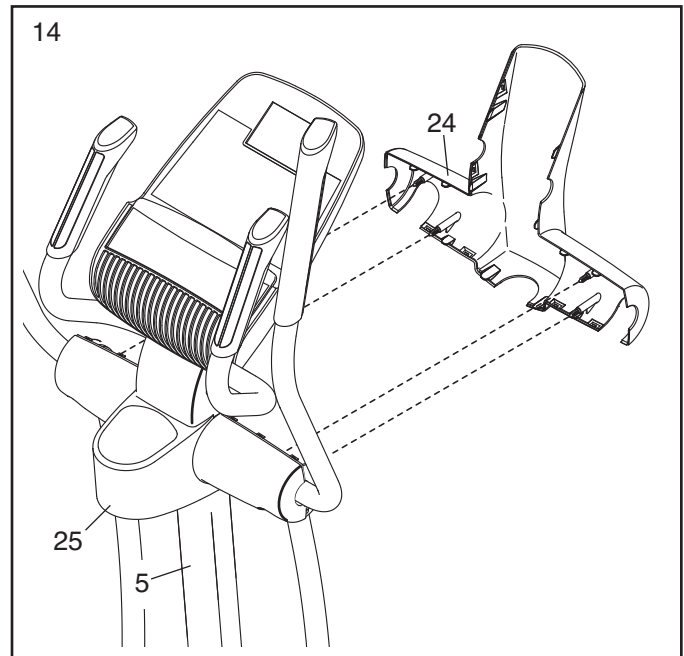

15. **Make sure that all parts of the elliptical are properly tightened.** Note: An extra grease packet and some hardware may be left over after assembly is completed. To protect the floor or carpet from damage, place a mat under the elliptical.

HOW TO USE THE ELLIPTICAL

HOW TO PLUG IN THE POWER CORD

This product must be grounded. If it should malfunction or break down, grounding provides a path of least resistance for electric current to reduce the risk of electric shock. This product is equipped with a cord having an equipment-grounding conductor and a grounding plug.

Plug the power cord into an appropriate outlet that is properly installed and grounded in accordance with all local codes and ordinances. This product is for use on a nominal 120-volt circuit. IMPORTANT: The elliptical is not compatible with GFCI-equipped outlets.

⚠ DANGER: Improper connection of the equipment-grounding conductor can result in an increased risk of electric shock. Check with a qualified electrician or serviceman if you are in doubt as to whether the product is properly grounded. Do not modify the plug provided with the product—if it will not fit the outlet, have a proper outlet installed by a qualified electrician.

A temporary adapter may be used to connect the power cord to a 2-pole receptacle as shown at the right if a properly grounded outlet is not available. The temporary adapter should be used only until a properly grounded outlet can be installed by a qualified electrician.

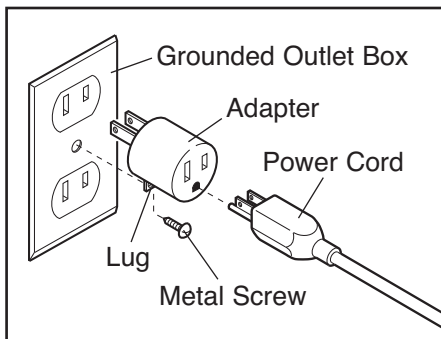

The green-colored rigid ear, lug, or the like extending from the adapter must be connected to a permanent ground such as a properly grounded outlet box cover. Whenever the adapter is used, it must be held in place by a metal screw. **Some 2-pole receptacle outlet box covers are not grounded. Contact a qualified electrician to determine if the outlet box cover is grounded before using an adapter.**

HOW TO FOLD AND UNFOLD THE ELLIPTICAL

When the elliptical is not in use, the frame can be folded out of the way. First, lift the latch under each pedal arm, and lift the pedal arms off the sleeves on the crank arms.

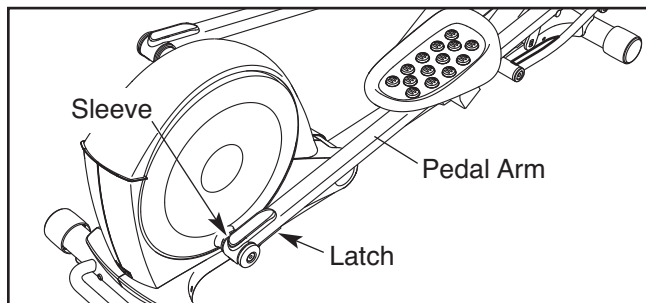

Next, raise the pedal arms until the magnets on the pedal arms touch the handlebars; the magnets will hold the pedal arms in place. Then, hold the handle and lift the frame until it locks in a vertical position.

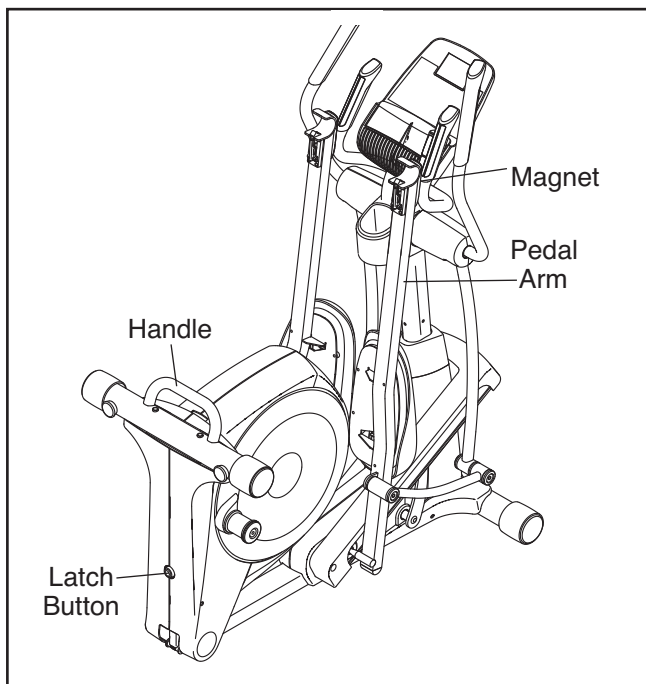

To use the elliptical, first hold the handle, press the latch button, and lower the frame.

Next, pull the magnets on the pedal arms off the handlebars. Then, **lift the latches under the pedal arms**, and set the pedal arms on the sleeves on the crank arms. Release the latches, and make sure that the pedal arms are securely connected to the crank arms.

HOW TO MOVE THE ELLIPTICAL

To move the elliptical, first fold it as described on page 14. Next, stand in front of the elliptical, hold the upright, and place one foot against one of the wheels. Pull the upright until the elliptical rolls on the wheels. With the help of a second person, carefully move the elliptical to the desired location, and then lower it to the floor.

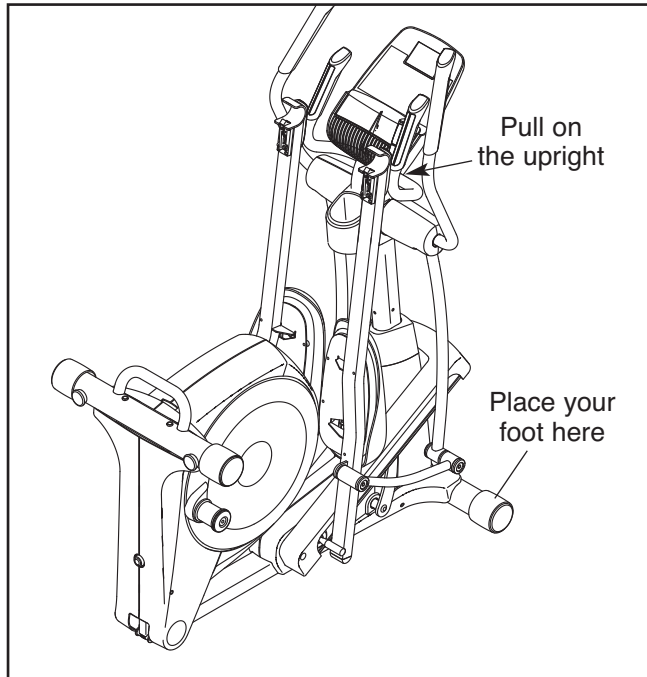

HOW TO EXERCISE ON THE ELLIPTICAL

To mount the elliptical, hold the upper body arms and step onto the pedal that is in the lowest position. Next, step onto the other pedal. Push the pedals until they begin to move with a continuous motion.

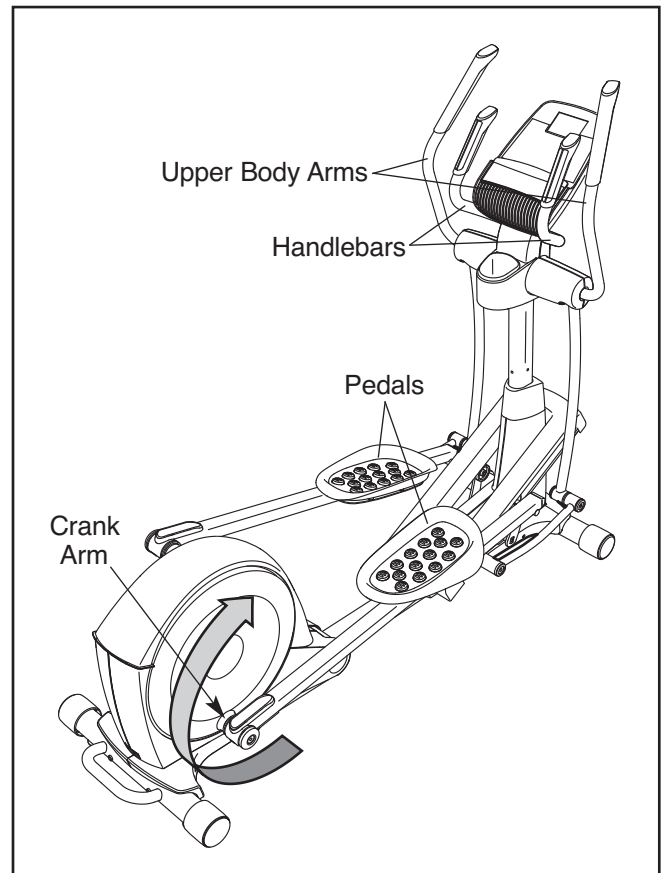

HOW TO LEVEL THE ELLIPTICAL

If the elliptical rocks slightly on your floor during use, turn one or both of the leveling feet beneath the rear stabilizer until the rocking motion is eliminated.

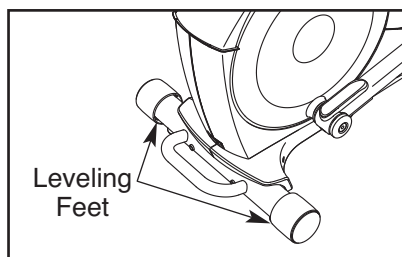

If the frame of the elliptical flexes during use, turn the center leveling foot until the flexing motion is eliminated.

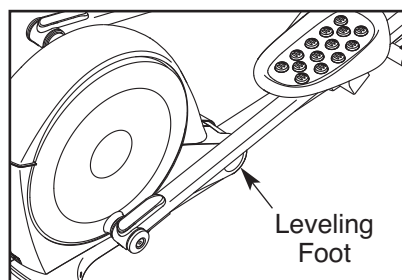

Note: The crank arms can turn in either direction. It is recommended that you turn the crank arms in the direction shown by the arrow; however, for variety you can turn the crank arms in the opposite direction.

To dismount the elliptical, wait until the pedals come to a complete stop. **Note: The elliptical does not have a free wheel; the pedals will continue to move until the flywheel stops.** When the pedals are stationary, step off the higher pedal first. Then, step off the lower pedal.

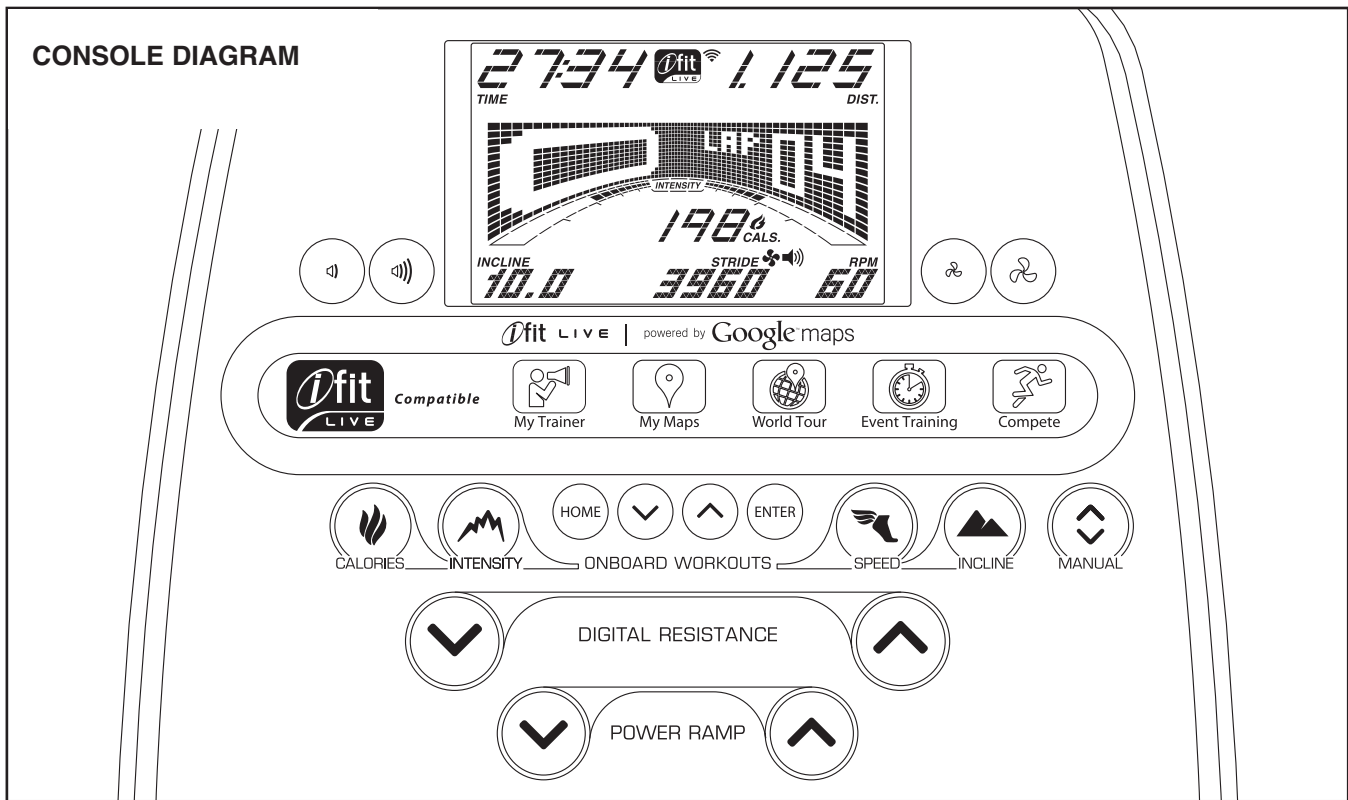

FEATURES OF THE CONSOLE

The advanced console offers an array of features designed to make your workouts more effective and enjoyable.

When you use the manual mode of the console, you can change the resistance of the pedals and the incline of the ramp with the touch of a button. While you exercise, the console will display continuous exercise feedback. You can also measure your heart rate using the handgrip pulse sensor.

In addition, the console offers eighteen onboard workouts—five calories workouts, five intensity workouts, four speed workouts, and four incline workouts. Each workout automatically changes the resistance of the pedals and the incline of the ramp and prompts you to vary your pedaling pace as it guides you through an effective workout.

The console also features an iFit Live mode that enables the console to communicate with your wireless network through an optional iFit Live module. With the iFit Live mode, you can download personalized workouts, create your own workouts, track your workout results, race against other runners, and access many other features. **To purchase an iFit Live module at any time, go to www.iFit.com or call the telephone number on the front cover of this manual.**

You can even connect your MP3 player or CD player to the console sound system and listen to your favorite music or audio books while you exercise.

To turn on the power, see page 17. **To use the manual mode**, see page 17. **To use an onboard workout**, see page 19. **To use an iFit Live workout**, see page 21. **To use the sound system**, see page 22. **To change console settings**, see page 22.

Note: If there is a sheet of plastic on the display, remove the plastic.

HOW TO TURN ON THE POWER

IMPORTANT: If the elliptical has been exposed to cold temperatures, allow it to warm to room temperature before turning on the power. If you do not do this, you may damage the console displays or other electrical components.

Plug in the power cord (see HOW TO PLUG IN THE POWER CORD on page 14). Next, locate the power switch on the frame near the power cord. Make sure that the power switch is in the reset position.

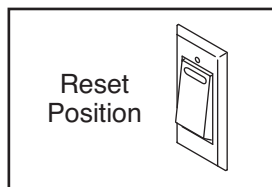

The display will then light and the console will be ready for use.

Note: When you turn on the power for the first time, the ramp will calibrate automatically. The ramp will move upward and downward as it calibrates. When the ramp stops moving, the ramp is calibrated.

IMPORTANT: If the ramp does not calibrate automatically, see HOW TO CALIBRATE THE RAMP on page 23 and manually calibrate the ramp.

HOW TO USE THE MANUAL MODE

1. **Begin pedaling or press any button on the console to turn on the console.**

See HOW TO TURN ON THE POWER above.

2. **Select the manual mode.**

Press the Manual button on the console. If you are not connected to iFit Live, the manual mode will be selected automatically.

3. **Change the resistance of the pedals and the incline of the ramp as desired.**

As you pedal, change the resistance of the pedals by pressing the Digital Resistance increase and decrease buttons.

Note: After you press the buttons, it will take a moment for the pedals to reach the selected resistance level.

To vary the motion of the pedals, you can change the incline of the ramp. To change the incline, press the Power Ramp increase and decrease buttons.

Note: After you press the button, it will take a moment for the ramp to reach the selected incline level.

4. **Follow your progress with the display.**

The display can show the following workout information:

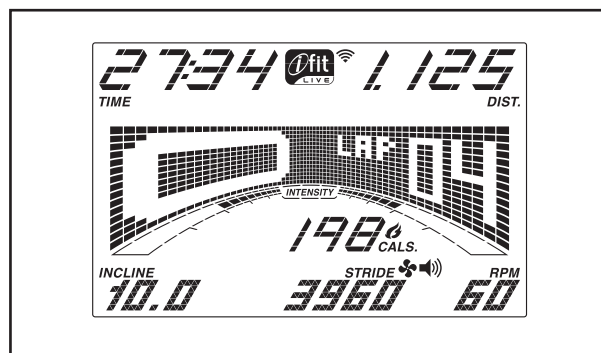

Calories (Cals.)—This display mode will show the approximate number of calories you have burned.

Calories per Hour (Cals./Hr)—This display mode will show the approximate number of calories you are burning per hour.

Distance (Dist.)—This display mode will show the distance that you have pedaled in miles or kilometers.

Incline—This display mode will show the incline level of the ramp for a few seconds each time the ramp incline level changes.

Pulse—This display mode will show your heart rate when you use the handgrip pulse sensor (see step 5).

Resistance (Resist.)—This display mode will show the resistance level of the pedals for a few seconds each time the resistance level changes.

RPM—This display mode will show your pedaling speed in revolutions per minute (rpm).

Stride—This display mode will show the total number of strides you have pedaled.

Time—When the manual mode is selected, this display mode will show the elapsed time. When a workout is selected, this display mode will show the time remaining in the workout.

The matrix offers several display tabs. Press the increase and decrease buttons next to the Enter button until the desired tab is shown.

Incline—This tab will show a profile of the incline settings of the workout. A new segment will appear at the end of each minute.

Speed—This tab will show a profile of the speed settings of the workout. A new segment will appear at the end of each minute.

My Trail—This tab will show a track that represents 640 revolutions (1/4 mile or 400 meters). As you exercise, the white rectangle will show your progress. The My Trail tab will also show the number of laps you are completing.

Calorie—This tab will show the approximate amount of calories you have burned. The height of each segment represents the amount of calories burned during that segment.

As you exercise, the workout intensity level bar will indicate the approximate intensity level of your exercise.

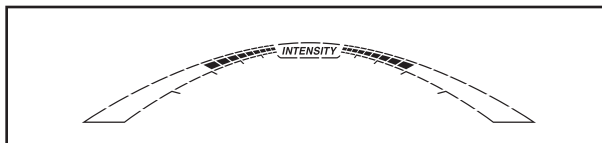

Press the Home button to exit the manual mode or a workout and return to the default menu (see HOW TO CHANGE CONSOLE SETTINGS on page 22 to set the default menu). If necessary, press the Home button again.

When a wireless iFit Live module is connected, the wireless symbol at the top of the display will show the strength of your wireless signal. Four arcs indicate full signal strength.



Change the volume level of the console by pressing the Volume increase and decrease buttons.

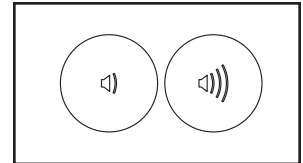

5. Measure your heart rate if desired.

If there are sheets of plastic on the metal contacts on the handgrip pulse sensor, remove the plastic. To measure your heart rate, hold the handgrip pulse sensor with your palms resting against the metal contacts. **Avoid moving your hands or gripping the contacts tightly.**

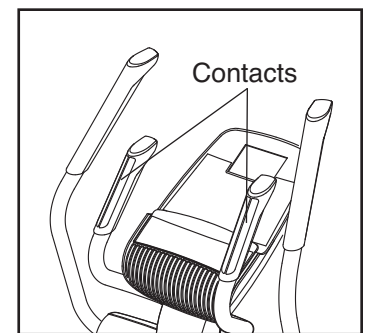

When your pulse is detected, a heart symbol in the calorie display will flash each time your heart beats, one or two dashes will appear, and then your heart rate will be shown. For the most accurate heart rate reading, hold the contacts for at least 15 seconds.

If the display does not show your heart rate, make sure that your hands are positioned as described. Be careful not to move your hands excessively or to squeeze the metal contacts tightly. For optimal performance, clean the metal contacts using a soft cloth; **never use alcohol, abrasives, or chemicals to clean the contacts.**

6. Turn on the fan if desired.

The fan has high and low speed settings. Press the Fan increase button repeatedly to turn on or increase the speed of the fan. Press the Fan decrease button repeatedly to decrease the speed or turn off the fan.

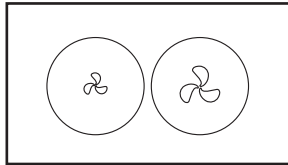

Note: If the pedals do not move for about thirty seconds, the fan will turn off automatically.

7. When you are finished exercising, unplug the power cord.

If the pedals do not move for several seconds, a tone will sound and the console will pause.

If the pedals do not move for several minutes and the buttons are not pressed, the console will turn off and the display will be reset.

When you are finished exercising, press the power switch to the off position and unplug the power cord. **IMPORTANT: If you do not do this, the electrical components on the elliptical may wear prematurely.**

HOW TO USE AN ONBOARD WORKOUT

1. Begin pedaling or press any button on the console to turn on the console.

See HOW TO TURN ON THE POWER on page 17.

2. Select an onboard workout.

To select an onboard workout, press the Calories button, the Intensity button, the Speed button, or the Incline button repeatedly until the desired workout appears in the display.

When you select an onboard workout, the display will show the duration of the workout and the name of the workout. A profile of the speed settings of the workout will appear in the matrix.

The resistance level, the ramp incline level, and the target rpm for the first segment will also appear in the matrix.

If you select a calorie workout, the approximate number of calories you will burn will appear in the name of the workout.

3. Begin pedaling to start the workout.

Each workout is divided into one-minute segments. One resistance level, one ramp incline level, and one target rpm (speed) is programmed for each segment. Note: The same resistance level, ramp incline level and/or target rpm may be programmed for consecutive segments.

During the workout, the profiles on the speed and incline tabs will show your progress.

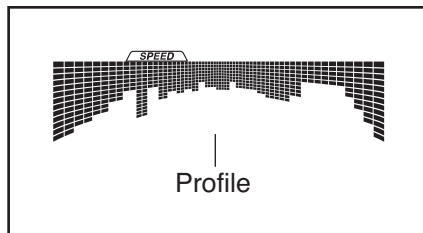

The flashing segment of the profile represents the current segment of the workout. The height of the flashing segment indicates your pedaling speed or the incline level for the current segment.

At the end of each segment of the workout, a series of tones will sound and the next segment of the profile will begin to flash. If a different resistance level, ramp incline level, and/or target rpm is programmed for the next segment, the resistance level, ramp incline level and/or target rpm will appear in the display for a few seconds to alert you. The resistance of the pedals and the incline level of the ramp will then change.

As you exercise, you will be prompted to keep your pedaling speed near the target rpm for the current segment. When an upward-pointing arrow appears in the display, increase your pace. When a downward-pointing arrow appears, decrease your pace. When no arrow appears, maintain your current pace.

IMPORTANT: The target rpm is intended only to provide motivation. Your actual pedaling speed may be slower than the target rpm. Make sure to pedal at a speed that is comfortable for you.

If the resistance level or incline level for the current segment is too high or too low, you can manually override the setting by pressing the Digital Resistance buttons or the Power Ramp buttons. **IMPORTANT: When the current segment of the workout ends, the pedals will automatically adjust to the resistance level programmed for the next segment and the ramp will automatically adjust to the incline level programmed for the next segment.**

Note: The calorie goal is an estimate of the number of calories that you will burn during the workout. The actual number of calories that you burn will depend on your weight. In addition, if you manually change the resistance level or if your pedaling speed does not match the target rpm during the workout, the number of calories you burn will be affected.

The workout will continue in this way until the last segment ends. To stop the workout at any time, stop pedaling. The time will flash in the display. To resume the workout, simply resume pedaling.

4. Follow your progress with the display.

See step 4 on page 17.

5. Measure your heart rate if desired.

See step 5 on page 18.

6. Turn on the fan if desired.

See step 6 on page 19.

7. When you are finished exercising, unplug the power cord.

See step 7 on page 19.

HOW TO USE AN iFIT LIVE WORKOUT

1. Begin pedaling or press any button on the console to turn on the console.

See HOW TO TURN ON THE POWER on page 17.

2. Insert the iFit Live module into the console.

To use an iFit Live workout, insert the iFit Live module into the console. To purchase an iFit Live module at any time, go to www.iFit.com or call the telephone number on the front cover of this manual. You must have an iFit Live module to use an iFit Live workout.

Note: To use an iFit Live module, you must have access to a computer with an internet connection and a USB port. You will also need an iFit.com membership. To use a wireless iFit Live module, you must also have your own wireless network including an 802.11b router with SSID broadcast enabled (hidden networks are not supported).

3. Select a user.

If more than one user is registered, you can switch users in the iFit Live main screen. Press the increase and decrease buttons next to the Enter button to select a user.

4. Select an iFit Live workout.

To select an iFit Live workout, press one of the iFit Live buttons. Before a workout will download, you must add the workout to your queue on www.iFit.com.

Press the iFit Live button to download the next workout in your queue. Press the My Trainer button, the My Maps button, the World Tour button, or the Event Training button to download the next workout of that type in your queue. Press the Compete button to compete in a race that you have previously scheduled. For more information on the iFit Live workouts, please see www.iFit.com.

When you select an iFit Live workout, the display will show the duration of the workout and the approximate number of calories you will burn. The display may also show the name of the workout. If you select a competition workout, the display may count down to the beginning of the race.

5. Start the workout.

See step 3 on page 19.

During some workouts, the voice of a personal trainer will guide you through your workout. You can select an audio setting for your personal trainer (see HOW TO CHANGE CONSOLE SETTINGS on page 22).

To stop the workout at any time, stop pedaling. The time will flash in the display. To resume the workout, simply resume pedaling.

6. Follow your progress with the displays.

See step 4 on page 17.

The My Trail tab will show a map of the trail you are walking or running or it will show a track and the number of laps you are completing.

During a competition workout, the Competition tab will show your progress in the race. As you race, the top line in the matrix will show how much of the race you have completed. The other lines will show other competitors. The end of the matrix represents the end of the race.

7. Measure your heart rate if desired.

See step 5 on page 18.

8. Turn on the fan if desired.

See step 6 on page 19.

9. When you are finished exercising, unplug the power cord.

See step 7 on page 19.

For more information on the iFit Live mode, go to www.iFit.com.

HOW TO USE THE SOUND SYSTEM

To play music or audio books through the console sound system while you exercise, plug the included audio cable into the jack on the console and into a jack on your MP3 player or CD player; **make sure that the audio cable is fully plugged in.**

Next, press the play button on your MP3 player or CD player. Adjust the volume level using the Volume increase and decrease buttons on the console or the volume control on your MP3 player or CD player.

HOW TO CHANGE CONSOLE SETTINGS

The console features a user mode that keeps track of elliptical information and allows you to personalize console settings.

To select the user mode, hold down the Fan increase button until the user mode information appears in the display.

The time display will show the total number of hours the elliptical has been used.

The distance display will show the total distance (in miles or kilometers) that the pedals have moved.

The lower section of the display will show the status of an iFit Live module. If a wireless iFit Live module is connected, the display will show the words WIFI MODULE. If a USB module is connected, the display will show the words USB/SD MODULE. If no module is connected, the display will show the words NO IFIT MODULE.

The matrix will show the selected unit of measurement. To change the unit of measurement, press the Enter button. To view distance in kilometers, select METRIC. To view distance in miles, select ENGLISH.

Press the decrease button next to the Enter button. The display will show the contrast level of the display. Press the Power Ramp increase and decrease buttons to adjust the contrast level.

If a wireless iFit Live module is connected, press the decrease button next to the Enter button to view the status of the personal trainer voice. To turn on or turn off the voice of the personal trainer, press the Enter button.

If a wireless iFit Live module is connected, press the decrease button next to the Enter button to view the default menu. The default menu will appear when you turn on the power. Press the Enter button repeatedly to select the manual main screen or the iFit Live main screen as the default menu.

If a wireless iFit Live module is connected, press the decrease button next to the Enter button to view the status of an iFit Live module. Press the Enter button to check the status of an iFit Live module. If a wireless iFit Live module is connected, the display will show the words CHECK WIFI STATUS. If a USB module is connected, the display will show the words CHECK USB STATUS. If no module is connected, the display will show the words NO MODULE DETECTED.

If a wireless iFit Live module is connected, press the decrease button next to the Enter button to transfer data. To send and receive workouts, workout logs, and updates, press the Enter button. When the process is finished, the words TRANSFERS DONE will appear in the display.

To exit the user mode, press the Fan increase button.

MAINTENANCE AND TROUBLESHOOTING

Inspect and tighten all parts of the elliptical regularly. Replace any worn parts immediately.

To clean the elliptical, use a damp cloth and a small amount of mild soap. **IMPORTANT: To avoid damage to the console, keep liquids away from the console and keep the console out of direct sunlight.**

CONSOLE TROUBLESHOOTING

If the console does not turn on, make sure that the power cord is fully plugged in. If lines appear in the console display, see **HOW TO CHANGE CONSOLE SETTINGS** on page 22 and adjust the contrast level of the display.

If the handgrip pulse sensor does not function properly, see step 5 on page 18.

HOW TO CALIBRATE THE RAMP

If the ramp is not functioning properly, the ramp may need to be calibrated. To calibrate the ramp, press and hold the Calories button for several seconds until the test mode appears in the display.

Press the Calories button again. Then, press the Power Ramp increase or decrease button to calibrate the ramp. The ramp will move upward and downward as it calibrates.

When the ramp stops moving, the ramp is calibrated. Then, press the Calories button repeatedly to exit the calibration mode.

HOW TO ADJUST THE REED SWITCH

If the console does not display correct feedback, the reed switch should be adjusted.

To adjust the reed switch, first **unplug the power cord**. Using a flat screwdriver, release the tabs on the Access Cover (20) and pry the Access Cover upward off the elliptical.

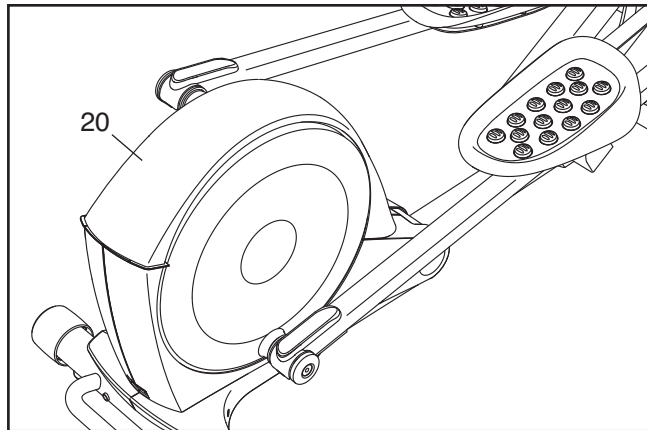

Next, look into the access opening and locate the Reed Switch (69). Rotate the Large Pulley (74) until a Pulley Magnet (75) is aligned with the Reed Switch.

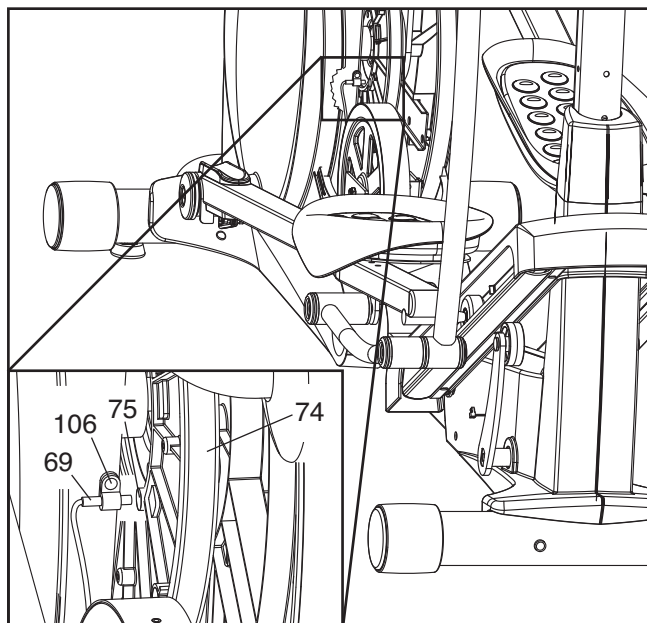

Next, loosen, but do not remove, the indicated M4 x 16mm Screw (106). Slide the Reed Switch (69) slightly toward or away from the Pulley Magnet (75). Then, retighten the M4 x 16mm Screw.

Plug in the power cord and rotate the large pulley for a moment. Repeat these actions until the console displays correct feedback. When the reed switch is correctly adjusted, reattach the access cover.

HOW TO ADJUST THE DRIVE BELT

If you can feel the pedals slip while you are pedaling, even when the resistance is adjusted to the highest level, the drive belt may need to be adjusted.

To adjust the drive belt, first **unplug the power cord**. Using a flat screwdriver, release the tabs on the Access Cover (20) and pry the Access Cover upward off the elliptical.

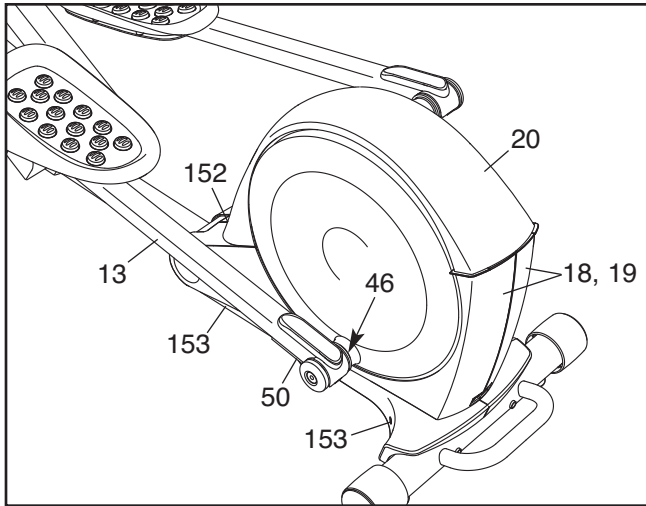

Next, lift the Latch (50) on the underside of the Left Pedal Arm (13), and then lift the Left Pedal Arm off the left Pedal Arm Sleeve (46).

Then, remove the four M4 x 16mm Round Head Screws (152) and the four M4 x 42mm Screws (153) from the Right and Left Shields (18, 19). (Note: Not all Screws are shown. Be sure to note which size Screws come from which holes.) Then, carefully remove the Left Shield.

Loosen the Pivot Screw (97). Tighten the Belt Adjustment Screw (85) until the Drive Belt (38) is tight. When the Drive Belt is tight, tighten the Pivot Screw.

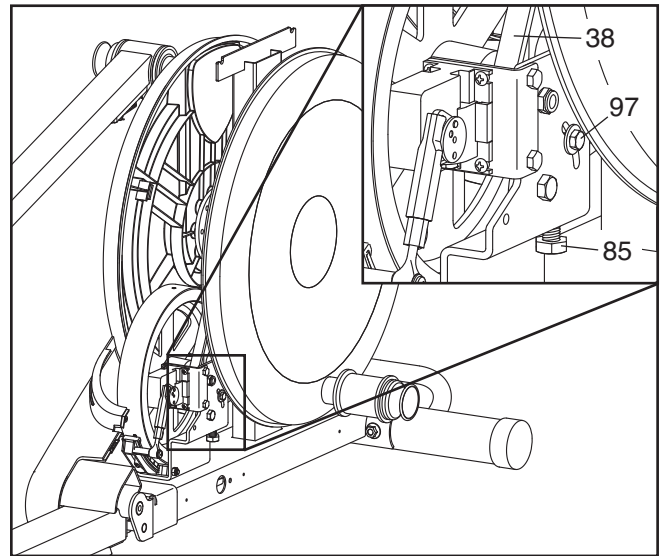

When you are finished, reattach the left shield, replace the left pedal arm, and reattach the access cover. Then, plug in the power cord.

EXERCISE GUIDELINES

⚠ WARNING: Before beginning this or any exercise program, consult your physician. This is especially important for persons over age 35 or persons with pre-existing health problems.

The pulse sensor is not a medical device. Various factors may affect the accuracy of heart rate readings. The pulse sensor is intended only as an exercise aid in determining heart rate trends in general.

These guidelines will help you to plan your exercise program. For detailed exercise information, obtain a reputable book or consult your physician. Remember, proper nutrition and adequate rest are essential for successful results.

EXERCISE INTENSITY

Whether your goal is to burn fat or to strengthen your cardiovascular system, exercising at the proper intensity is the key to achieving results. You can use your heart rate as a guide to find the proper intensity level. The chart below shows recommended heart rates for fat burning and aerobic exercise.

165	155	145	140	130	125	115	♥♥
145	138	130	125	118	110	103	♥
125	120	115	110	105	95	90	♥
20	30	40	50	60	70	80	

To find the proper intensity level, find your age at the bottom of the chart (ages are rounded off to the nearest ten years). The three numbers listed above your age define your “training zone.” The lowest number is the heart rate for fat burning, the middle number is the heart rate for maximum fat burning, and the highest number is the heart rate for aerobic exercise.

Burning Fat—To burn fat effectively, you must exercise at a low intensity level for a sustained period of time. During the first few minutes of exercise, your body uses *carbohydrate calories* for energy. Only after the first few minutes of exercise does your body begin to use stored *fat calories* for energy. If your goal is to burn fat, adjust the intensity of your exercise until your heart rate is near the lowest number in your training zone. For maximum fat burning, exercise with your heart rate near the middle number in your training zone.

Aerobic Exercise—If your goal is to strengthen your cardiovascular system, you must perform aerobic exercise, which is activity that requires large amounts of oxygen for prolonged periods of time. For aerobic exercise, adjust the intensity of your exercise until your heart rate is near the highest number in your training zone.

WORKOUT GUIDELINES

Warming Up—Start with 5 to 10 minutes of stretching and light exercise. A warm-up increases your body temperature, heart rate, and circulation in preparation for exercise.

Training Zone Exercise—Exercise for 20 to 30 minutes with your heart rate in your training zone. (During the first few weeks of your exercise program, do not keep your heart rate in your training zone for longer than 20 minutes.) Breathe regularly and deeply as you exercise—never hold your breath.

Cooling Down—Finish with 5 to 10 minutes of stretching. Stretching increases the flexibility of your muscles and helps to prevent post-exercise problems.

EXERCISE FREQUENCY

To maintain or improve your condition, complete three workouts each week, with at least one day of rest between workouts. After a few months of regular exercise, you may complete up to five workouts each week, if desired. Remember, the key to success is to make exercise a regular and enjoyable part of your everyday life.

SUGGESTED STRETCHES

The correct form for several basic stretches is shown at the right. Move slowly as you stretch—never bounce.

1. Toe Touch Stretch

Stand with your knees bent slightly and slowly bend forward from your hips. Allow your back and shoulders to relax as you reach down toward your toes as far as possible. Hold for 15 counts, then relax. Repeat 3 times. Stretches: Hamstrings, back of knees and back.

2. Hamstring Stretch

Sit with one leg extended. Bring the sole of the opposite foot toward you and rest it against the inner thigh of your extended leg. Reach toward your toes as far as possible. Hold for 15 counts, then relax. Repeat 3 times for each leg. Stretches: Hamstrings, lower back and groin.

3. Calf/Achilles Stretch

With one leg in front of the other, reach forward and place your hands against a wall. Keep your back leg straight and your back foot flat on the floor. Bend your front leg, lean forward and move your hips toward the wall. Hold for 15 counts, then relax. Repeat 3 times for each leg. To cause further stretching of the achilles tendons, bend your back leg as well. Stretches: Calves, achilles tendons and ankles.

4. Quadriceps Stretch

With one hand against a wall for balance, reach back and grasp one foot with your other hand. Bring your heel as close to your buttocks as possible. Hold for 15 counts, then relax. Repeat 3 times for each leg. Stretches: Quadriceps and hip muscles.

5. Inner Thigh Stretch

Sit with the soles of your feet together and your knees outward. Pull your feet toward your groin area as far as possible. Hold for 15 counts, then relax. Repeat 3 times. Stretches: Quadriceps and hip muscles.

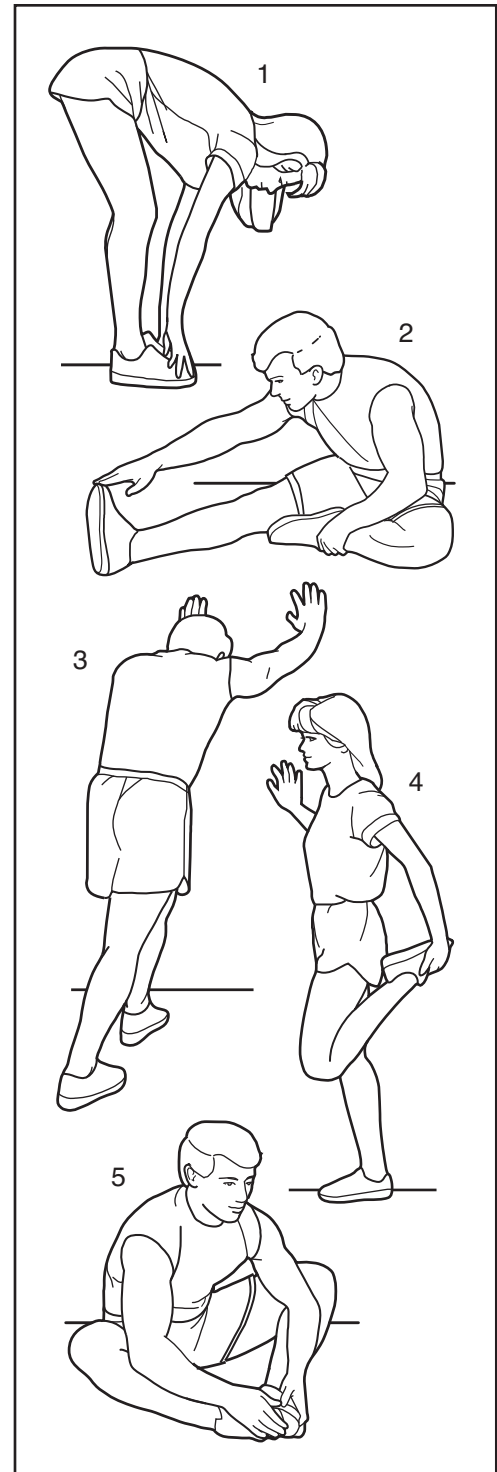

PART LIST—Model No. PFEL18010.0

R0810A

Key No.	Qty.	Description	Key No.	Qty.	Description
1	1	Main Frame	51	2	Large Latch Spring
2	1	Folding Frame	52	2	Latch Insert
3	1	Front Stabilizer	53	4	Long Latch Spring
4	1	Rear Stabilizer	54	16	Arm/Leg Bushing
5	1	Upright	55	4	M4 x 16mm Flat Head Screw
6	1	Right Upper Body Leg	56	6	Small Axle Cover
7	1	Left Upper Body Leg	57	2	Upright Bushing
8	1	Right Upper Body Arm	58	2	Outer Sleeve Bushing
9	1	Left Upper Body Arm	59	1	Audio Cable
10	1	Right Handlebar	60	1	Wire Harness
11	1	Left Handlebar	61	1	Flywheel
12	1	Right Pedal Arm	62	4	M6 x 50mm Patch Screw
13	1	Left Pedal Arm	63	1	Frame Axle
14	1	Right Pedal	64	4	Main Frame Bushing
15	1	Left Pedal	65	1	Latch Bracket Axle
16	2	Wheel Cap	66	1	Latch Bracket Spring
17	2	Disc	67	1	Latch Button
18	1	Right Shield	68	1	Button Housing
19	1	Left Shield	69	1	Reed Switch/Wire
20	1	Access Cover	70	1	Clamp
21	1	Right Frame Cover	71	1	Crank Hub
22	1	Left Frame Cover	72	1	Crank
23	2	Double Tree Fastener	73	1	Crank Spacer
24	1	Front Upright Cover	74	1	Large Pulley
25	1	Rear Upright Cover	75	2	Pulley Magnet
26	1	Water Bottle Holder	76	2	Folding Frame Bearing
27	1	Top Cover	77	1	Idler
28	2	Pedal Arm Cap	78	1	Resistance Motor
29	18	Mount w/Screw	79	1	Adjustment Assembly
30	2	Magnet Cover	80	1	Resistance Wheel
31	4	Pedal Arm Magnet	81	1	Adjustment Lock
32	2	Pedal Arm Roller	82	1	Motor Bracket
33	1	Console	83	1	C-magnet Bracket
34	2	Pulse Sensor/Wire	84	1	Flywheel Axle
35	2	Handgrip	85	1	Belt Adjustment Screw
36	2	Wheel	86	8	M8 x 28mm Patch Screw
37	2	Stabilizer Cap	87	2	Crank Snap Ring
38	1	Drive Belt	88	1	C-magnet Bracket Bolt
39	2	Crank Arm	89	4	Motor Screw
40	2	Hairpin Cotter Pin	90	1	M5 x 7mm Screw
41	3	Leveling Foot	91	1	M3.5 x 12mm Screw
42	1	Latch Bracket	92	1	M6 Locknut
43	1	Right Link Arm	93	1	Lift Arm Axle
44	2	Lift Bracket	94	2	M8 Jam Nut
45	2	Lift Axle Bushing	95	10	M8 Washer
46	2	Pedal Arm Sleeve	96	1	M6 Washer
47	2	Inner Sleeve Bushing	97	1	Pivot Screw
48	1	Upright Axle	98	2	Motor Bracket Screw
49	2	Latch Housing	99	1	Idler Bolt
50	2	Latch	100	4	M10 x 95mm Patch Screw

Key No.	Qty.	Description	Key No.	Qty.	Description
101	2	Small Pedal Arm Snap Ring	133	1	Ramp Axle
102	16	M8 x 16mm Patch Screw	134	1	Lift Motor
103	14	M8 Split Washer	135	1	Motor Wire Harness
104	2	Lift Arm Snap Ring	136	2	Ramp Roller
105	2	Pulse Wire	137	1	Long Motor Axle
106	15	M4 x 16mm Screw	138	1	Short Motor Axle
107	4	M10 x 20mm Button Screw	139	2	Lift Axle Washer
108	6	M10 Washer	140	2	Motor Spacer
109	8	M8 x 16mm Button Screw	141	2	Lift Axle Screw
110	2	M8 x 23.5mm x 1mm Washer	142	1	Left Lift Arm
111	4	M6 x 12mm Patch Screw	143	1	Right Lift Arm
112	8	M6 Washer	144	1	Left Link Arm
113	2	Large Axle Cover	145	1	Motor Power Wire Harness
114	2	Link Arm Axle	146	4	#6 x 3/8" Screw
115	1	Power Switch	147	1	Frame Wire Harness
116	1	Power Cord Grommet	148	1	Ground Wire
117	1	Flywheel Bearing	149	4	M8 x 35mm Patch Screw
118	2	Wave Washer	150	4	M8 x 38mm Screw
119	1	Power Cord	151	1	Right Gel Pad
120	1	Control Board	152	12	M4 x 16mm Round Head Screw
121	2	M8 x 25mm Patch Screw	153	4	M4 x 42mm Screw
122	1	3/8" x 1" Flange Screw	154	4	M4 x 8mm Screw
123	1	Control Box Cover	155	2	Large Pedal Arm Snap Ring
124	1	Control Box	156	8	M4 x 19mm Screw
125	1	Transformer	157	2	Gel Pad
126	2	M10 Locknut	158	1	Left Gel Pad
127	2	Long C-pin	*	–	Blue Wire
128	2	Short C-pin	*	–	White Wire
129	2	M4 x 12mm Screw	*	–	User's Manual
130	1	Ramp	*	–	Assembly Tool
131	1	Ramp Cover	*	–	Grease Packet
132	4	Ramp Bushing			

Note: Specifications are subject to change without notice. For information about ordering replacement parts, see the back cover of this manual. *These parts are not illustrated.

EXPLODED DRAWING A—Model No. PFEL18010.0

R0810A

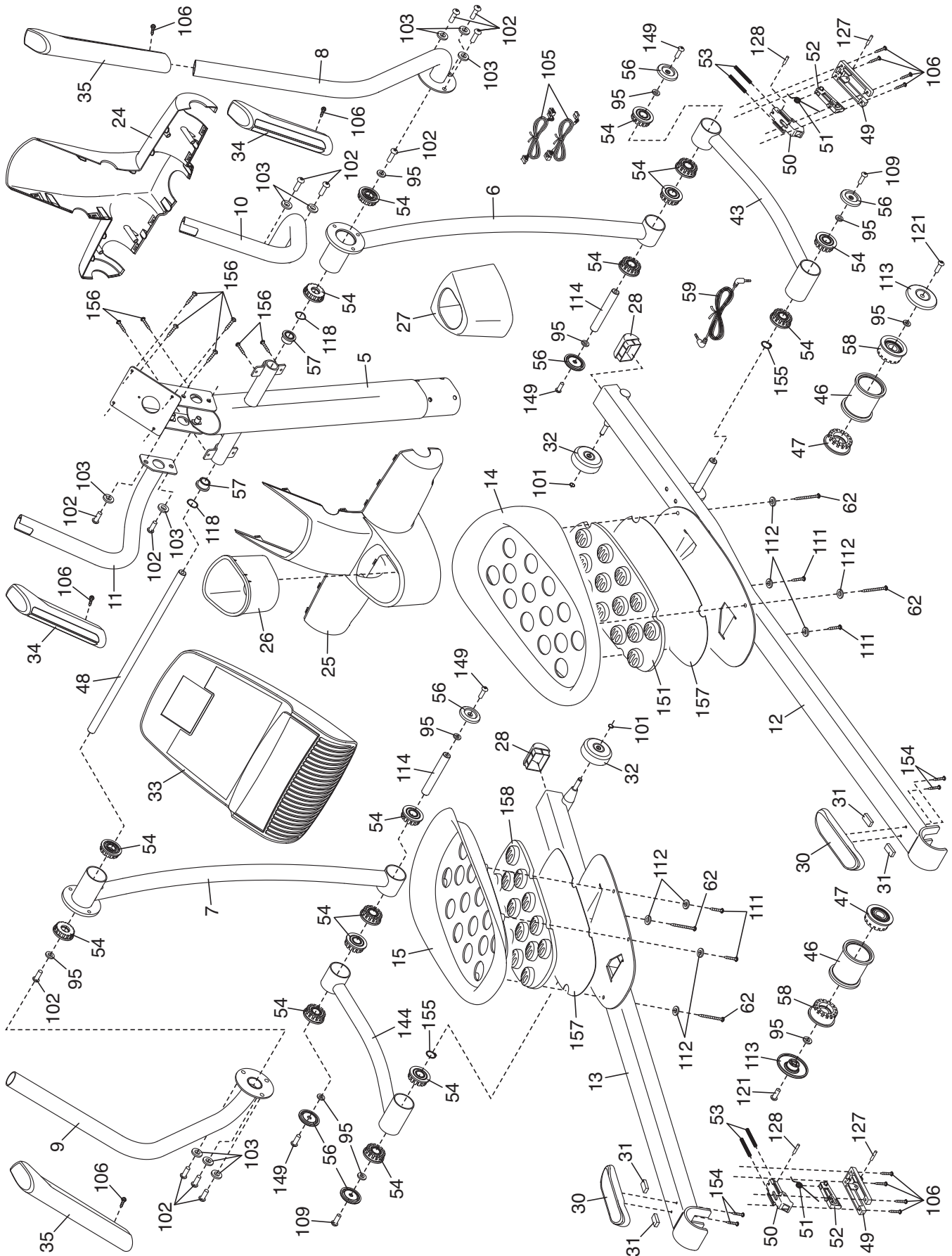

EXPLODED DRAWING B – Model No. PFEL18010.0

R0810A

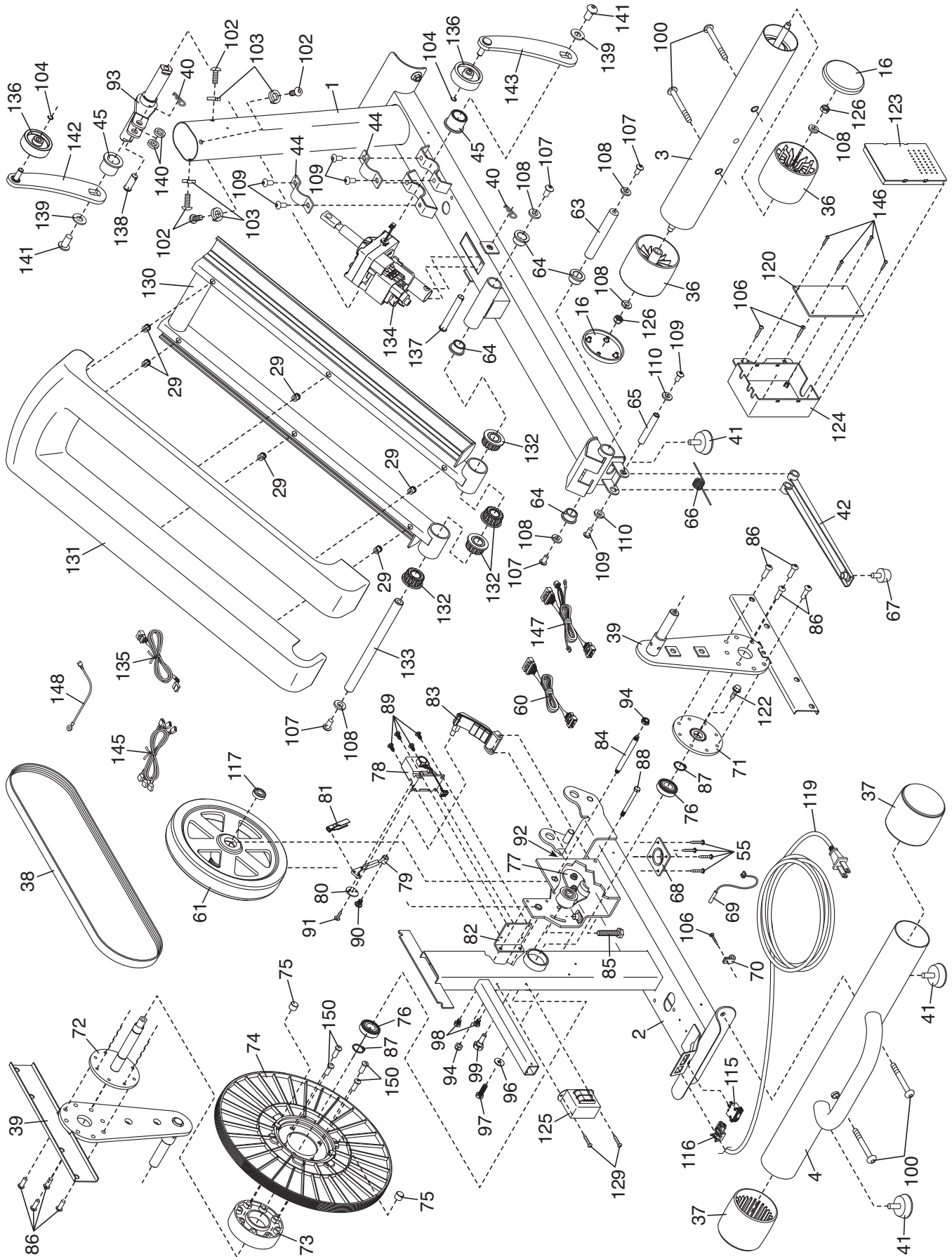

EXPLODED DRAWING C—Model No. PFEL18010.0

R0810A

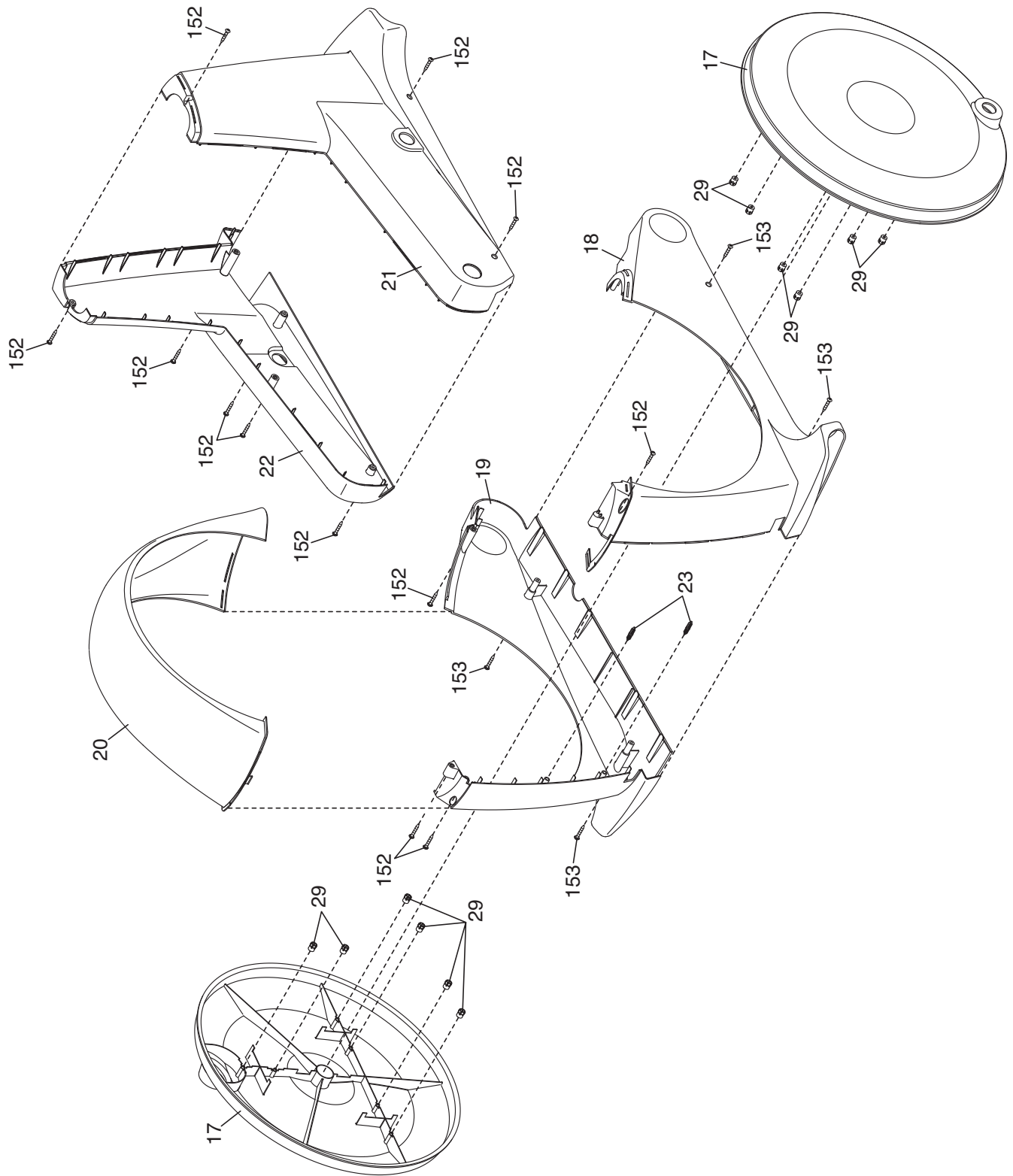

ORDERING REPLACEMENT PARTS

To order replacement parts, see the front cover of this manual. To help us assist you, please be prepared to provide the following information when contacting us:

- the model number and serial number of the product (see the front cover of this manual)
- the name of the product (see the front cover of this manual)
- the key number and description of the replacement part(s) (see the PART LIST and the EXPLODED DRAWING near the end of this manual)

LIMITED WARRANTY

IMPORTANT: You must register this product within 30 days of the purchase date to avoid added fees for service needed under warranty. Go to www.proformservice.com/registration.

ICON Health & Fitness, Inc. (ICON) warrants this product to be free from defects in workmanship and material, under normal use and service conditions. The frame is warranted for a lifetime. Parts and labor are warranted for one (1) year from the date of purchase.

This warranty extends only to the original purchaser. ICON's obligation under this warranty is limited to repairing or replacing, at ICON's option, the product through one of its authorized service centers. All repairs for which warranty claims are made must be preauthorized by ICON. If the product is shipped to a service center, freight charges to and from the service center will be the customer's responsibility. For replacement parts shipped while the product is under warranty, the customer will be responsible for a minimal handling charge. For in-home service, the customer will be responsible for a minimal trip charge. This warranty does not extend to any damage to a product caused by or attributable to freight damage, abuse, misuse, improper or abnormal usage, or repairs not provided by an ICON authorized service center; to products used for commercial or rental purposes or as store display models; or to products transported or purchased outside the US. No other warranty beyond that specifically set forth above is authorized by ICON.

ICON is not responsible or liable for indirect, special, or consequential damages arising out of or in connection with the use or performance of the product; damages with respect to any economic loss, loss of property, loss of revenues or profits, loss of enjoyment or use, or costs of removal or installation; or other consequential damages of whatsoever nature. Some states do not allow the exclusion or limitation of incidental or consequential damages. Accordingly, the above limitation may not apply to you.

The warranty extended hereunder is in lieu of any and all other warranties, and any implied warranties of merchantability or fitness for a particular purpose are limited in their scope and duration to the terms set forth herein. Some states do not allow limitations on how long an implied warranty lasts. Accordingly, the above limitation may not apply to you.

This warranty gives you specific legal rights. You may also have other rights that vary from state to state.

ICON Health & Fitness, Inc., 1500 S. 1000 W., Logan, UT 84321-9813