

# PRO-FORM<sup>®</sup>

## 18.0 RE

[www.proform.com](http://www.proform.com)

Model No. PFEL59911.2

Serial No. \_\_\_\_\_

Write the serial number in the space above for reference.

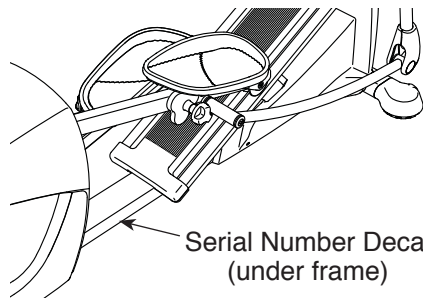

## USER'S MANUAL

### QUESTIONS?

If you have questions, or if parts are damaged or missing, **DO NOT CONTACT THE STORE**; please contact Customer Care.

**IMPORTANT:** Please register this product (see the limited warranty on the back cover of this manual) before contacting Customer Care.

CALL TOLL-FREE:

**1-888-533-1333**

Mon.–Fri., 6 a.m.–6 p.m. MT

Sat. 8 a.m.–4 p.m. MT

ON THE WEB:

[www.proformservice.com](http://www.proformservice.com)

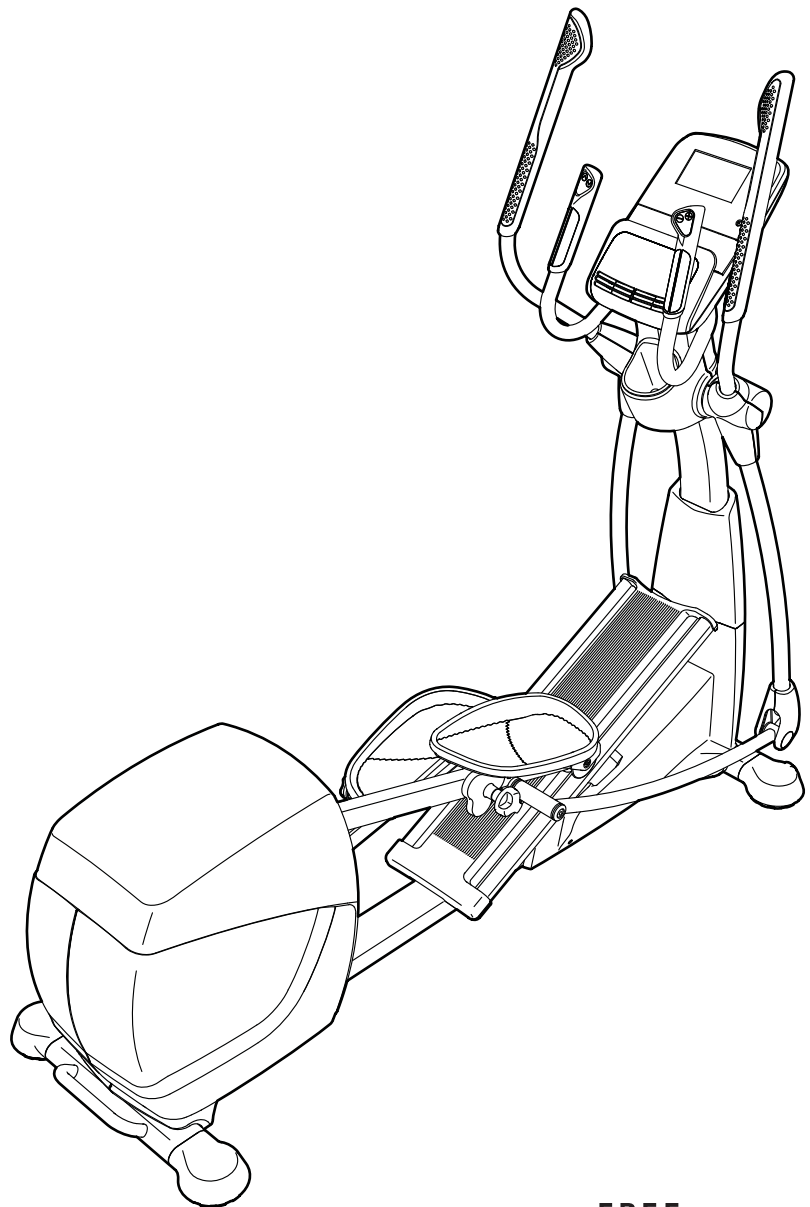

### CAUTION

Read all precautions and instructions in this manual before using this equipment. Keep this manual for future reference.



# TABLE OF CONTENTS

WARNING DECAL PLACEMENT .....	2
IMPORTANT PRECAUTIONS .....	3
BEFORE YOU BEGIN .....	4
PART IDENTIFICATION CHART .....	5
ASSEMBLY .....	6
HOW TO USE THE ELLIPTICAL .....	14
FCC INFORMATION .....	22
MAINTENANCE AND TROUBLESHOOTING .....	24
EXERCISE GUIDELINES .....	26
PART LIST .....	27
EXPLODED DRAWING .....	29
ORDERING REPLACEMENT PARTS .....	Back Cover
LIMITED WARRANTY .....	Back Cover

## WARNING DECAL PLACEMENT

This drawing shows the location(s) of the warning decal(s). **If a decal is missing or illegible, see the front cover of this manual and request a free replacement decal. Apply the decal in the location shown.** Note: The decal(s) may not be shown at actual size.

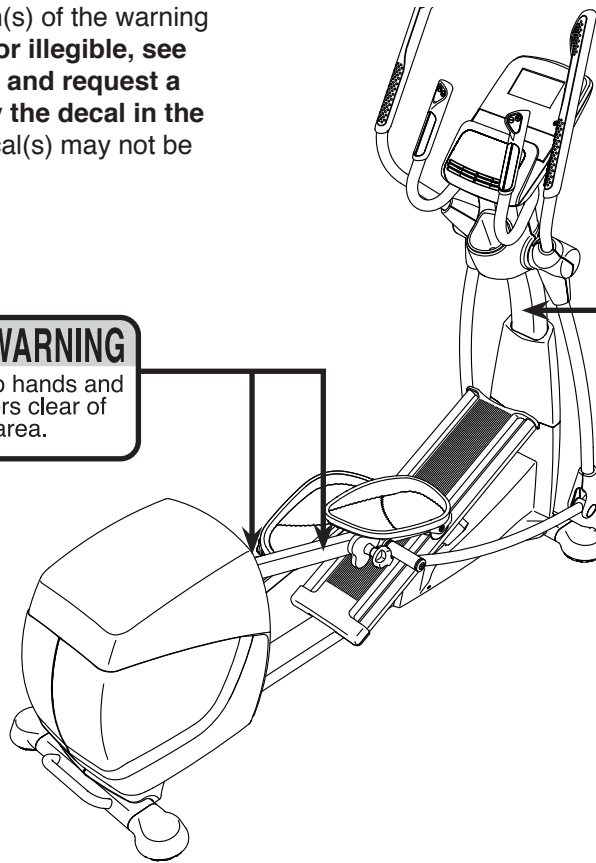

**WARNING**

- Misuse of this machine may result in serious injury.
- Read user's manual prior to use and follow all warnings and instructions.
- Do not allow children on or around machine.
- Pedals continue to spin when you stop pedaling.
- Spinning pedals can cause injury.
- Reduce pedal speed in a controlled manner.
- User weight must not exceed 325 pounds.
- Replace label if damaged, illegible, or removed.



---

# IMPORTANT PRECAUTIONS

**⚠ WARNING:** To reduce the risk of serious injury, read all important precautions and instructions in this manual and all warnings on your elliptical before using your elliptical. ICON assumes no responsibility for personal injury or property damage sustained by or through the use of this product.

1. Before beginning any exercise program, consult your physician. This is especially important for persons over age 35 or persons with pre-existing health problems.
2. Use the elliptical only as described in this manual.
3. It is the responsibility of the owner to ensure that all users of the elliptical are adequately informed of all precautions.
4. The elliptical is intended for home use only. Do not use the elliptical in a commercial, rental, or institutional setting.
5. Keep the elliptical indoors, away from moisture and dust. Do not put the elliptical in a garage or covered patio, or near water.
6. Place the elliptical on a level surface, with at least 3 ft. (0.9 m) of clearance in the front and rear of the elliptical and 2 ft. (0.6 m) on each side. To protect the floor or carpet from damage, place a mat under the elliptical.
7. Inspect and properly tighten all parts regularly. Replace any worn parts immediately.
8. Keep children under age 12 and pets away from the elliptical at all times.
9. The elliptical should not be used by persons weighing more than 325 lbs. (147 kg).
10. Wear appropriate clothes while exercising; do not wear loose clothes that could become caught on the elliptical. Always wear athletic shoes for foot protection while exercising.
11. Hold the handlebars or the upper body arms when mounting, dismounting, or using the elliptical.
12. The heart rate monitor is not a medical device. Various factors may affect the accuracy of heart rate readings. The heart rate monitor is intended only as an exercise aid in determining heart rate trends in general.
13. The elliptical does not have a freewheel; the pedals will continue to move until the flywheel stops. Reduce your pedaling speed in a controlled way.
14. Keep your back straight while using the elliptical; do not arch your back.
15. Over exercising may result in serious injury or death. If you feel faint or if you experience pain while exercising, stop immediately and cool down.

# BEFORE YOU BEGIN

Thank you for selecting the revolutionary PROFORM® 18.0 RE elliptical. The 18.0 RE elliptical provides an impressive selection of features designed to make your workouts at home more effective and enjoyable.

**For your benefit, read this manual carefully before you use the elliptical.** If you have questions after reading this manual, please see the front cover of this

manual. To help us assist you, note the product model number and serial number before contacting us. The model number and the location of the serial number decal are shown on the front cover of this manual.

Before reading further, please familiarize yourself with the parts that are labeled in the drawing below.

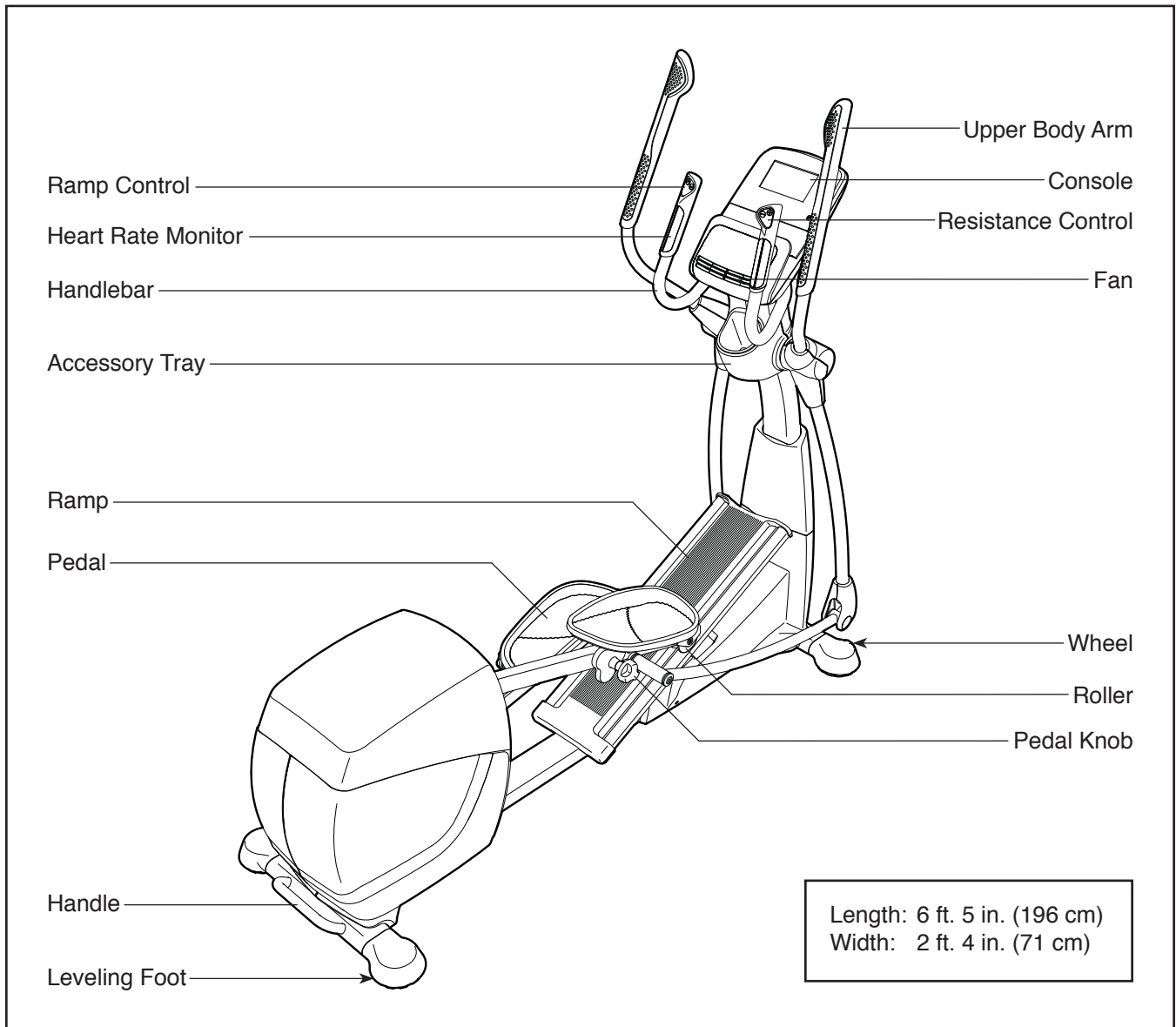

# PART IDENTIFICATION CHART

Use the drawings below to identify the small parts needed for assembly. The number in parentheses below each drawing is the key number of the part, from the PART LIST near the end of this manual. The number following the key number is the quantity needed for assembly. **Note: If a part is not in the hardware kit, check to see if it has been preassembled. Extra parts may be included.**

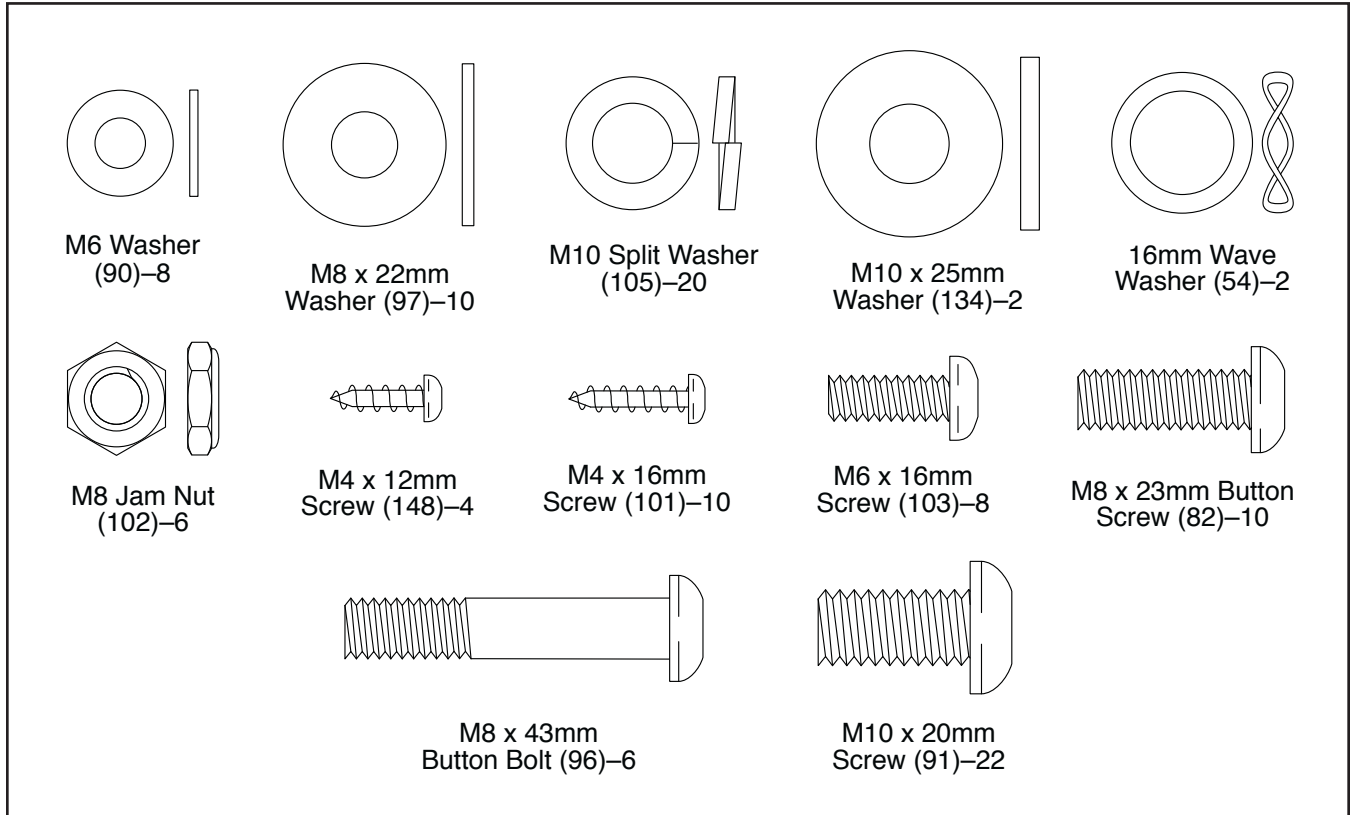

# ASSEMBLY

- To hire an authorized service technician to assemble the elliptical, call 1-800-445-2480.
- Assembly requires two persons.
- Place all parts in a cleared area and remove the packing materials. Do not dispose of the packing materials until you complete all assembly steps.
- To identify small parts, see page 5.

- In addition to the included tool(s), assembly requires the following tools:

one Phillips screwdriver 

one rubber mallet 

Assembly may be easier if you have your own set of wrenches. To avoid damaging parts, do not use power tools.

1. Remove and discard the shipping brackets (not shown) on the front and rear of the Frame (1).

Identify the Front Right Stabilizer Tube (145), which has a Wheel (34) in the indicated location.

While a second person lifts the front of the Frame (1), insert some packaging materials (not shown) under the Frame. **Have the second person hold the Frame to prevent it from tipping.**

Attach the Front Right Stabilizer Tube (145) to the Frame (1) with three M10 x 20mm Screws (91) and three M10 Split Washers (105).

**Attach the Left Front Stabilizer Tube (not shown) in the same way.**

Then, remove the packaging materials.

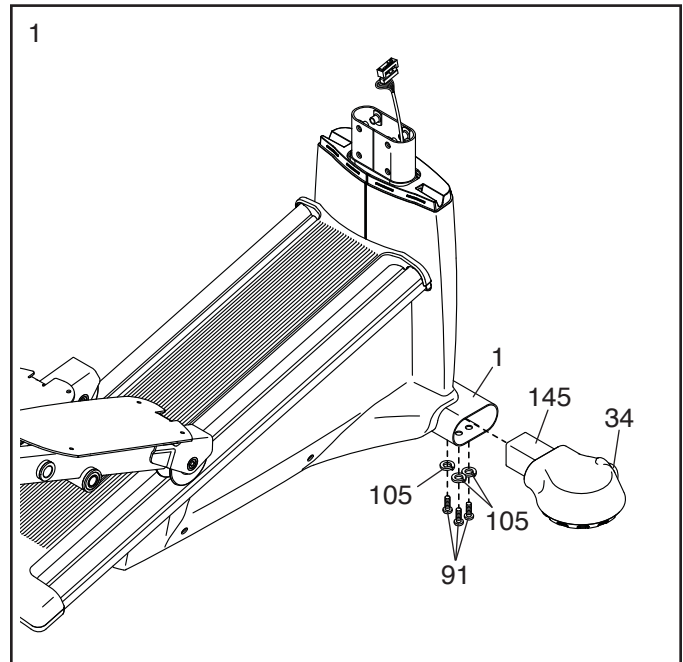

2. Identify the two Rear Stabilizer Tubes (2).

While a second person lifts the rear of the Frame (1), insert some packaging materials (not shown) under the Frame. **Have the second person hold the Frame to prevent it from tipping.**

Attach a Rear Stabilizer Tube (2) to the Frame (1) with three M10 x 20mm Screws (91) and three M10 Split Washers (105).

**Attach the other Rear Stabilizer Tube (2) in the same way.**

Next, tighten the Small Leveling Foot (136) into the Frame (1) in the indicated location.

Then, remove the packaging materials.

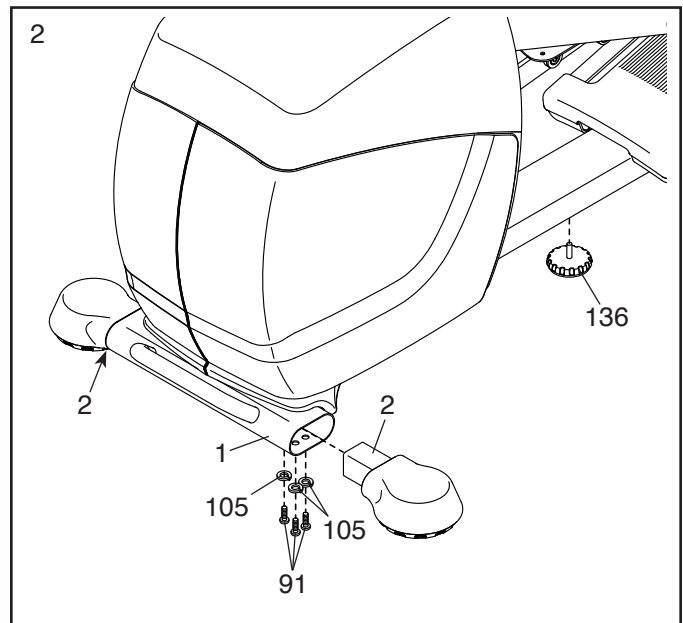

3. Identify the Upright Cover (81). Orient the Upright Cover as shown, and slide it upward onto the Upright (4).

Have a second person hold the Upright (4) and the Upright Cover (81) near the Frame (1).

Connect the Upper Wire (152) to the Lower Wire (111).

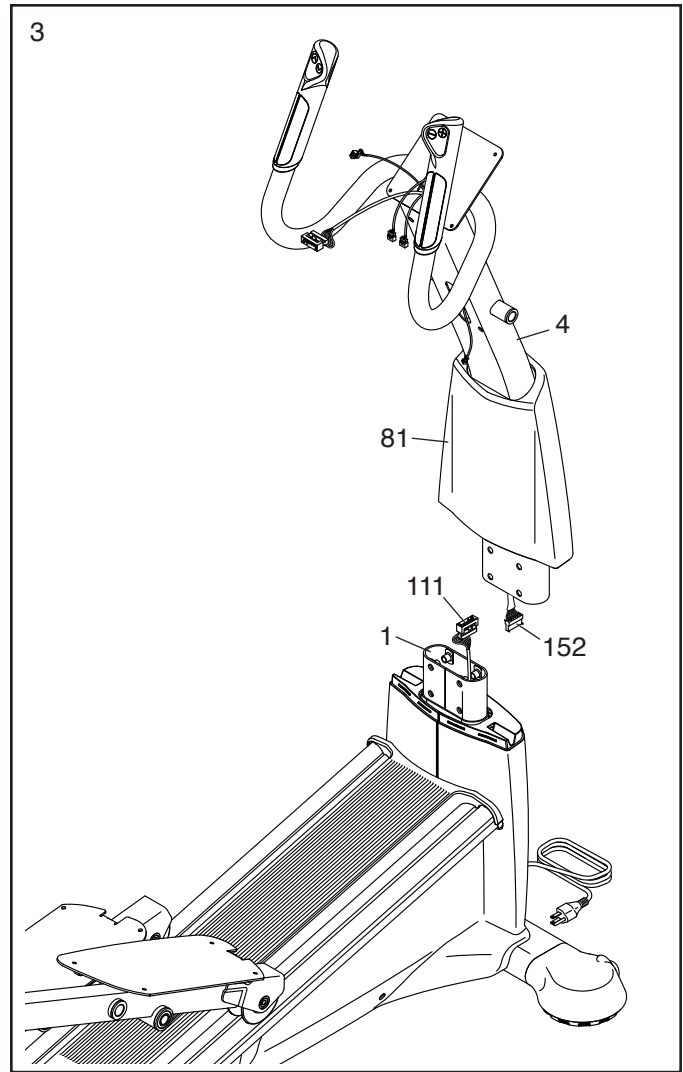

4. **Tip: Avoid pinching the wires.** Slide the Upright (4) onto the Frame (1).

Attach the Upright (4) with eight M10 x 20mm Screws (91) and eight M10 Split Washers (105). **Do not tighten the Button Screws yet.**

Slide the Upright Cover (81) downward. **Do not press the Upright Cover into the Left and Right Front Shields (73, 74) yet.**

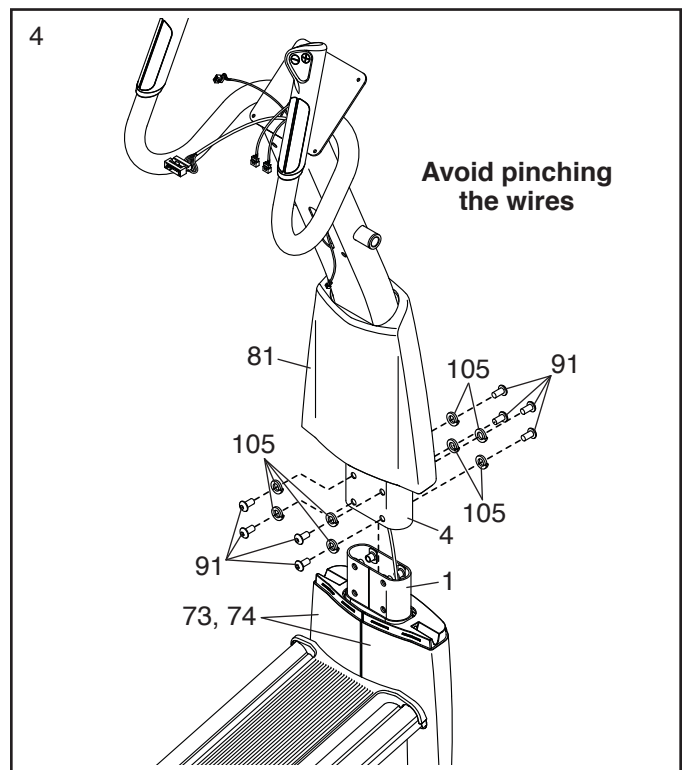

5. Identify the Right Upper Body Arm (61) and the Right Upper Body Leg (60), which are marked with "Right" stickers, and orient them as shown.

Attach the Right Upper Body Arm (61) to the Right Upper Body Leg (60) with three M8 x 43mm Button Bolts (96) and three M8 Jam Nuts (102). **Make sure that the Jam Nuts are in the indicated hexagonal holes. Do not tighten the Button Bolts yet.**

**Attach the Left Upper Body Arm (47) to the Left Upper Body Leg (46) in the same way.**

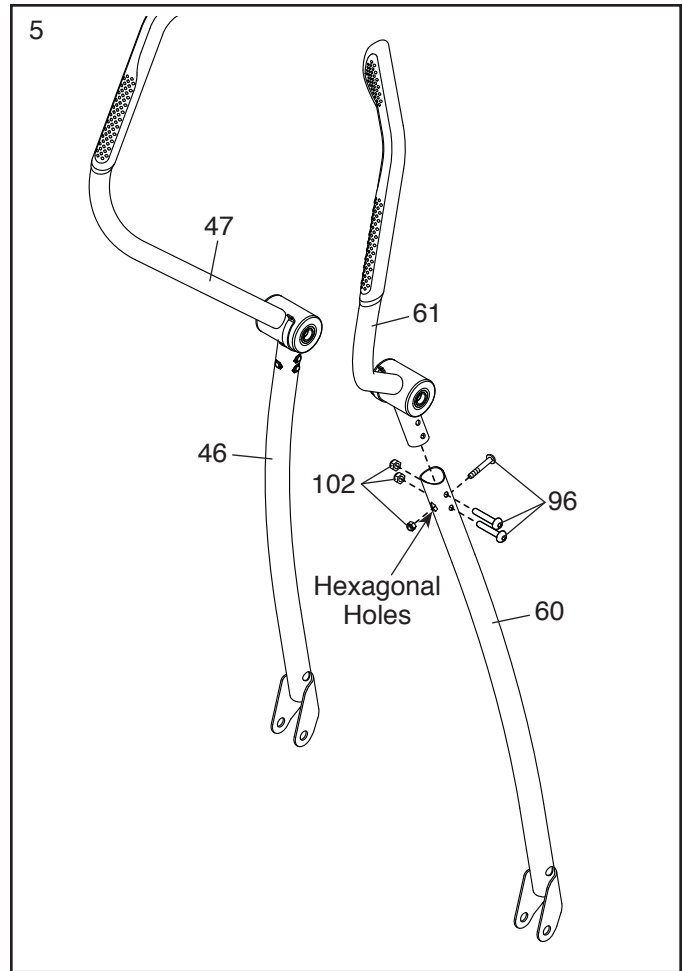

6. Using a plastic bag to keep your fingers clean, apply some of the included grease to the Long Axle (35) and to two 16mm Wave Washers (54) (only one is shown).

Insert the Long Axle (35) through the Upright (4) and center it.

Slide a 16mm Wave Washer (54) and the Right Upper Body Arm (61) onto the right side of the Long Axle (35).

**Repeat these actions for the Left Upper Body Arm (47).**

Tighten an M8 x 23mm Button Screw (82) and an M8 x 22mm Washer (97) into each end of the Long Axle (35) **at the same time.**

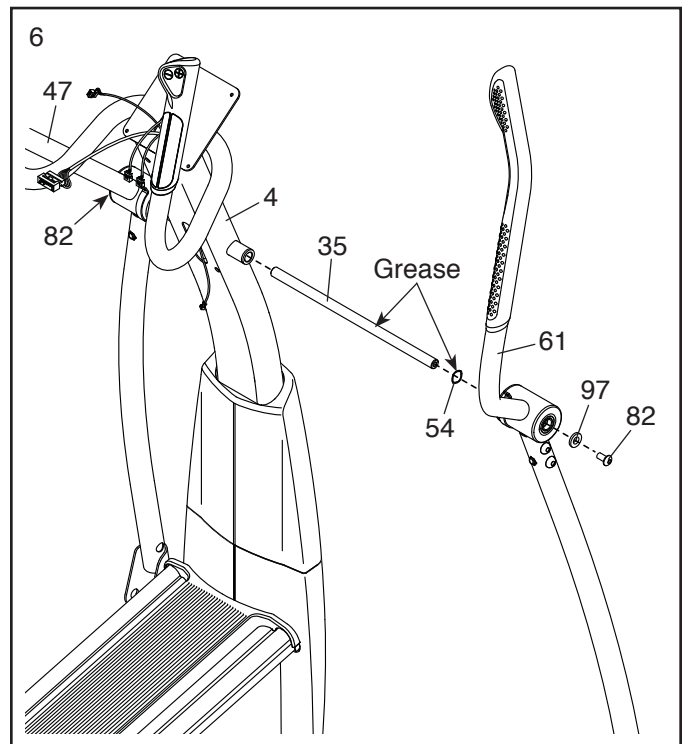



7. While a second person lifts the back of the Right Pedal Plate (14), insert the Right Pedal Bracket (133) into the Right Pedal Arm (58).

Attach the Right Pedal Bracket (133) with an M10 x 20mm Screw (91) and an M10 x 25mm Washer (134). **Do not overtighten the Screw; the Right Pedal Bracket must turn freely.**

**Repeat this step on the other side of the elliptical.**

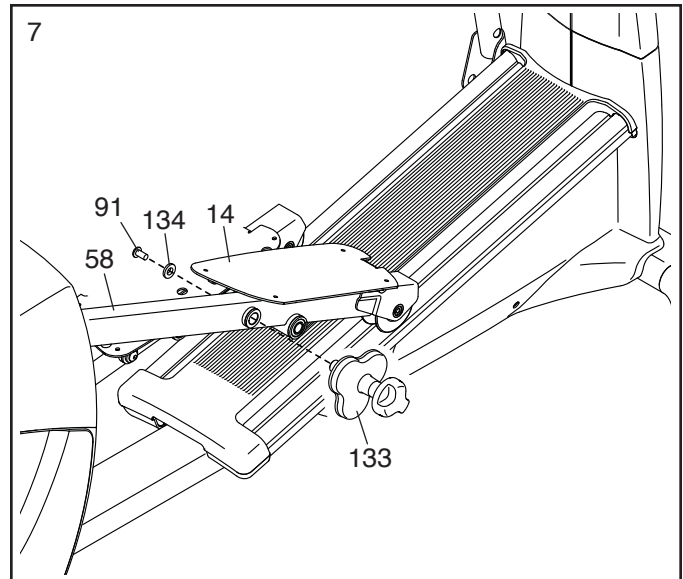

8. Identify the Right Pedal (49), which is marked with a “Right” sticker, and orient it as shown.

While a second person lifts the Right Pedal Plate (14), attach the Right Pedal (49) to the Right Pedal Plate with four M6 x 16mm Screws (103) and four M6 Washers (90). **Tip: It may be helpful to lift the Right Pedal Arm (58).**

**Attach the Left Pedal (12) to the Left Pedal Plate (not shown) in the same way.**

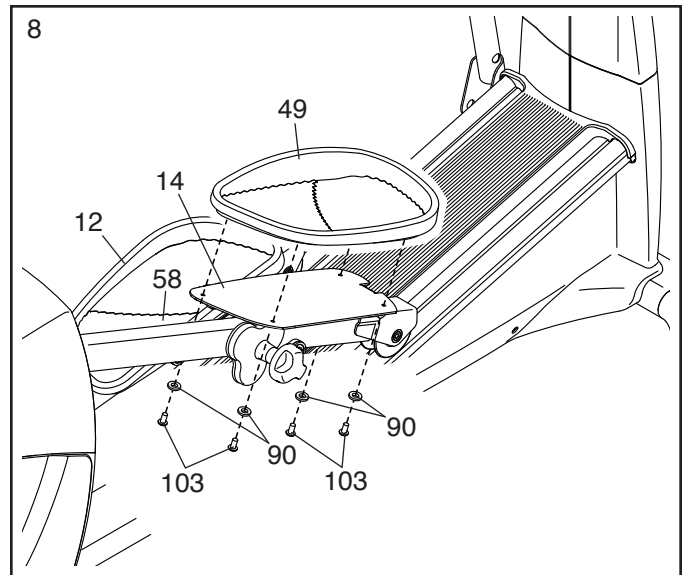

9. Apply grease to a Medium Axle (119) and to two M8 x 22mm Washers (97).

Identify the Right Link Arm (59), which is marked with a “Right” sticker, and orient it as shown.

Insert the Medium Axle through the Right Link Arm (59) and the Right Pedal Arm (58).

Tighten an M8 x 23mm Button Screw (82), an Axle Cover (55), and an M8 x 22mm Washer (97) into each end of the Medium Axle (119) **at the same time. To avoid damaging the plastic, do not overtighten the Button Screws.**

**Repeat this step on the other side of the elliptical.**

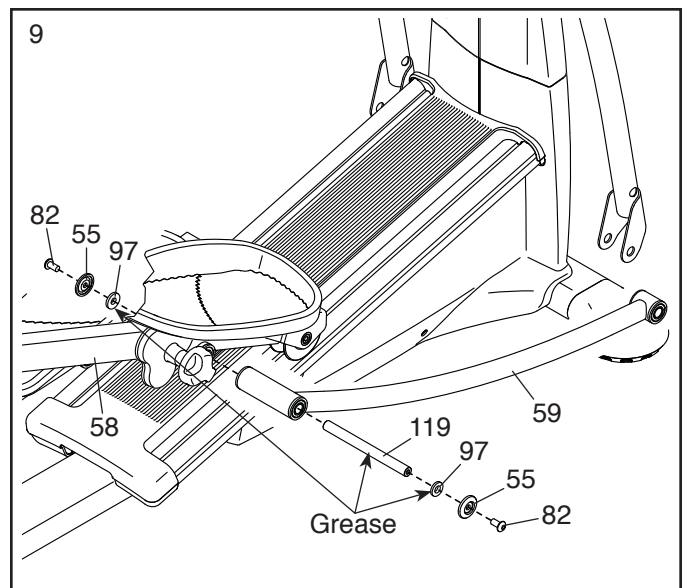

10. Apply grease to a Short Axle (149) and to two M8 x 22mm Washers (97).

Next, tighten an M8 x 23mm Button Screw (82) and an M8 x 22mm Washer (97) a few turns into the Short Axle (149).

While a second person holds the front end of the Right Link Arm (59) inside the bracket on the Right Upper Body Leg (60), insert the Short Axle (149) through both parts.

Tighten another M8 x 23mm Button Screw (82) and an M8 x 22mm Washer (97) a few turns into the Short Axle (149). **Then, tighten both Button Screws at the same time.**

**Repeat this step on the other side of the elliptical.**

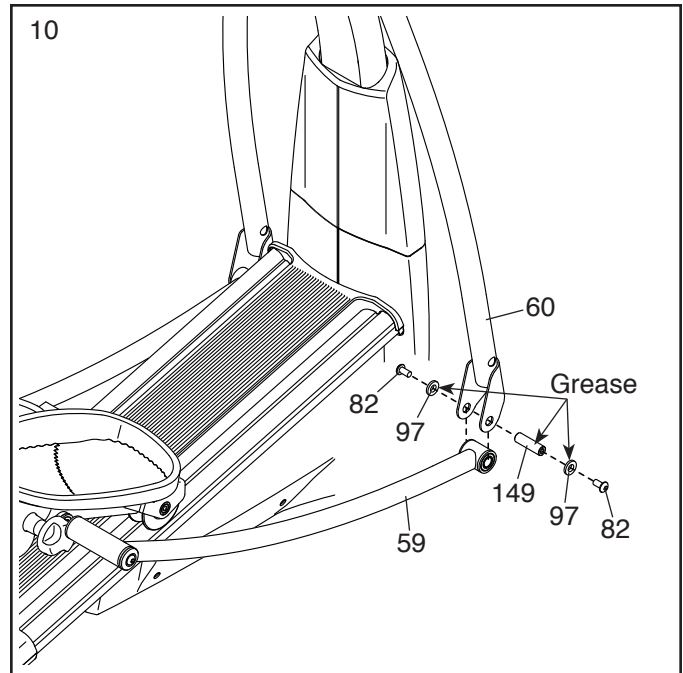

11. Identify the Right Inner and Outer Leg Covers (83, 69), which are marked with “Right” stickers, and orient them as shown.

Press the Right Inner and Outer Leg Covers (83, 69) together around the Right Upper Body Leg (60).

Attach the Right Inner and Outer Leg Covers (83, 69) to the Right Upper Body Leg (60) with an M4 x 16mm Screw (101). **To avoid damaging the plastic, do not overtighten the Screw.**

**Attach the Left Inner and Outer Leg Covers (72, 70) in the same way.**

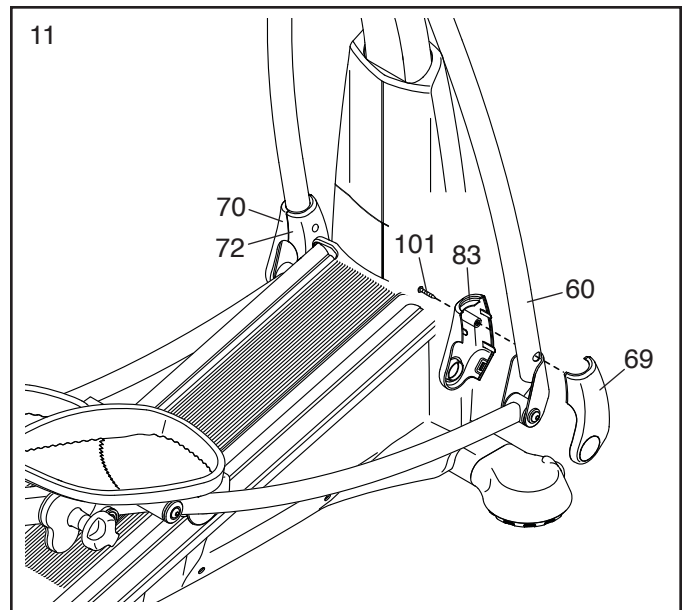

12. **IMPORTANT:** If you purchase the optional chest heart rate monitor (see page 22), see step 17 on page 13 to install the receiver included with the heart rate monitor.

Orient the Rear Console Cover (80) as shown.

Attach the Rear Console Cover (80) to the Upright (4) with four M4 x 16mm Screws (101).

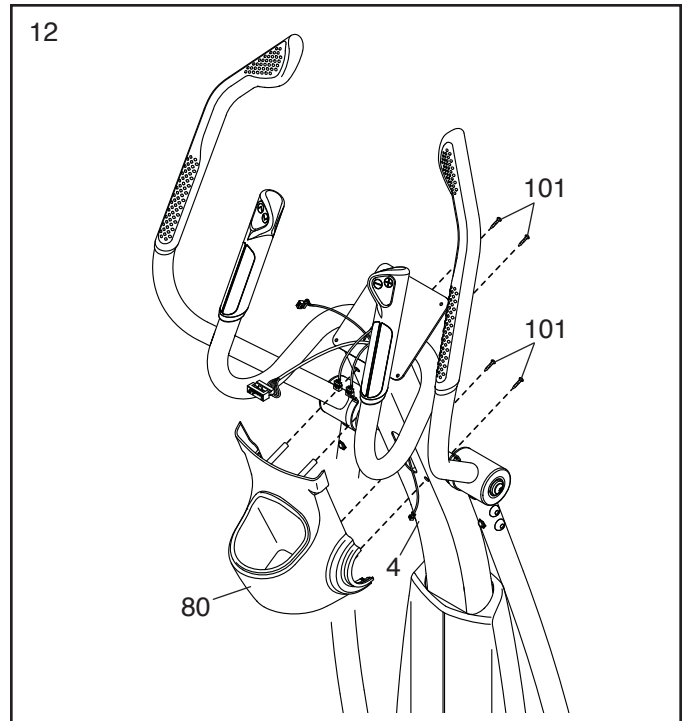

13. While a second person holds the Console (7) near the Upright (4), connect the wires on the Console to the Upper Wire (152), to the Right and Left Sensor Wires (108, 110), and to the Extension Wire (162).

Insert the excess wire into the Upright (4) or into the Console (7).

**Tip: Avoid pinching the wires.** Attach the Console (7) to the Upright (4) with four M4 x 12mm Screws (148).

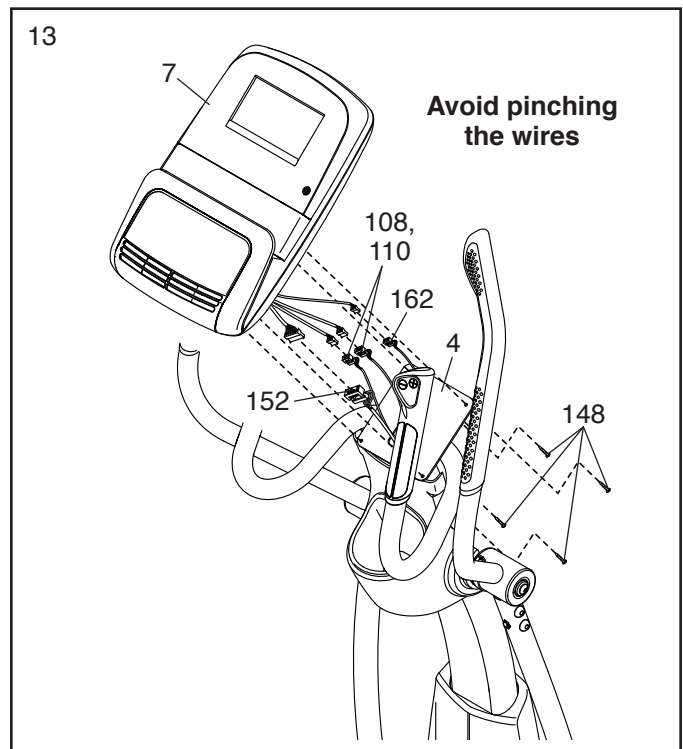

14. Attach the Front Console Cover (79) around the Upright (4) by pressing the tabs on the Front Console Cover into the Rear Console Cover (80).

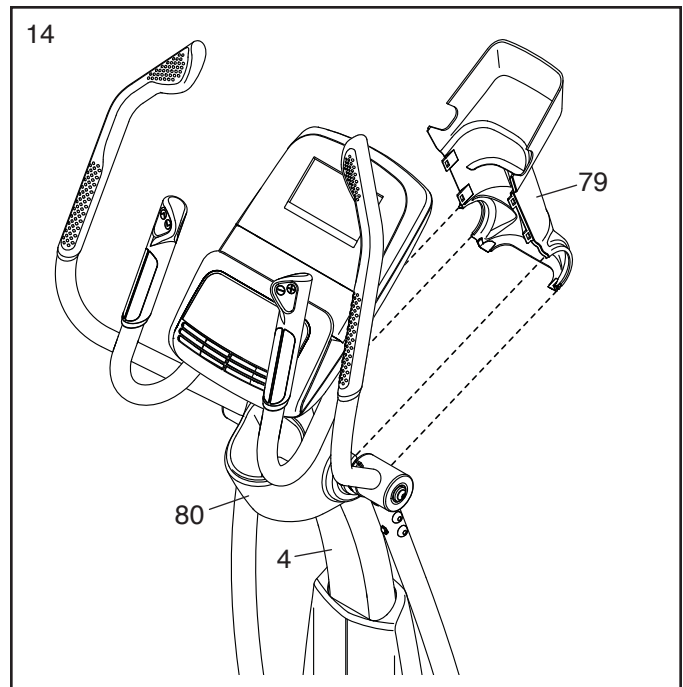

15. **See step 5.** Tighten the six M8 x 43mm Button Bolts (96).

**See step 4.** Tighten the eight M10 x 20mm Screws (91).

Identify the Right Front and Rear Arm Covers (65, 66), which are marked with "Right" stickers.

Attach the Right Front Arm Cover (65) to the Right Upper Body Arm (61) with two M4 x 16mm Screws (101).

Attach the Right Rear Arm Cover (66) around the Right Upper Body Arm (61) by pressing the tabs on the Right Rear Arm Cover into the Right Front Arm Cover (65).

**Attach the Left Front and Rear Arm Covers (67, 68) in the same way.**

Then, slide the Upright Cover (81) downward and press it into the Left and Right Front Shields (73, 74).

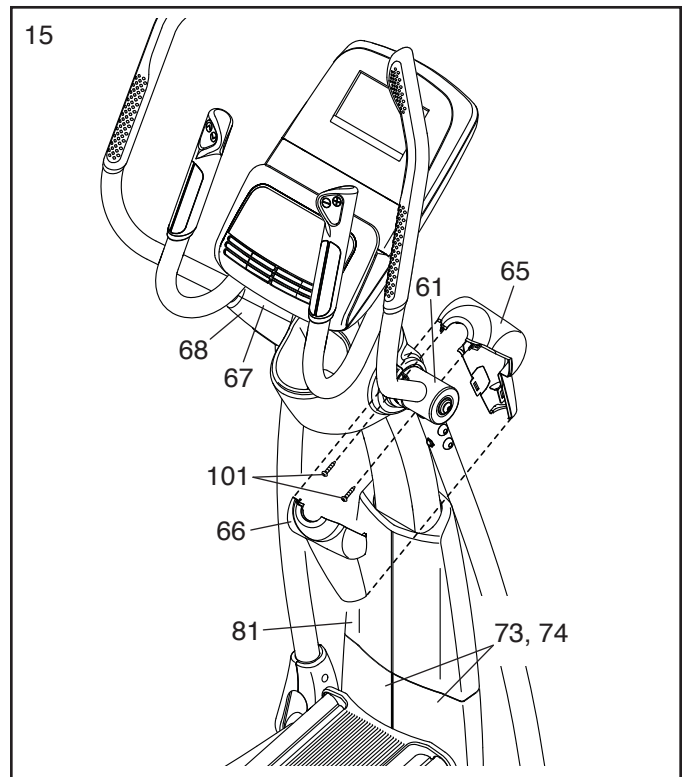

16. **Make sure that all parts of the elliptical are properly tightened.** Note: Some hardware may be left over after assembly is completed. To protect the floor or carpet from damage, place a mat under the elliptical.

If you purchase the optional heart rate monitor (see page 22), follow the step below to install the receiver included with the heart rate monitor.

**17. Complete this step before you begin step 12.**

Note: It will be necessary to reverse steps 15, 14, 13, and 12 if you have already completed assembly.

Remove the paper from the adhesive pad on the back of the Receiver (A). Press the Receiver onto the indicated location on the inside of the Rear Console Cover (80) **below** the Accessory Tray (37).

**See the inset drawing. Make sure that the antenna on the Receiver (A) is oriented in a horizontal position that is parallel to the ground.**

Connect the wire on the Receiver (A) to the Extension Wire (162).

Next, attach the Rear Console Cover (80) with four M4 x 16mm Screws (101). **Then, go to step 13.**

Note: Discard any other wires that are included with the heart rate monitor.

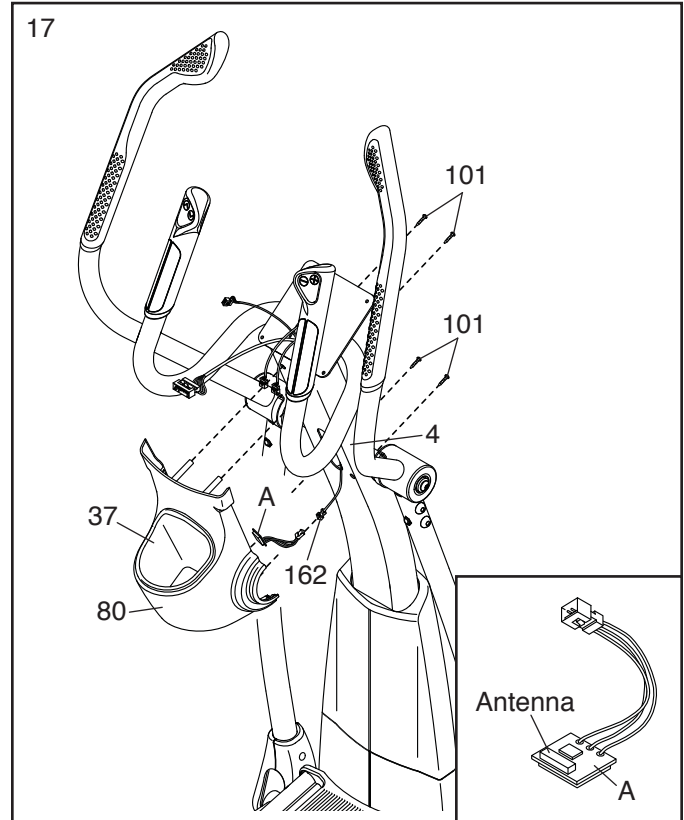

# HOW TO USE THE ELLIPTICAL

## HOW TO PLUG IN THE POWER CORD

**This product must be grounded.** If it should malfunction or break down, grounding provides a path of least resistance for electric current to reduce the risk of electric shock. This product is equipped with a cord having an equipment-grounding conductor and a grounding plug.

**Plug the power cord into an appropriate outlet that is properly installed and grounded in accordance with all local codes and ordinances. This product is for use on a nominal 120-volt circuit. IMPORTANT: The elliptical is not compatible with GFCI-equipped outlets and may not be compatible with AFCI-equipped outlets.**

**⚠ DANGER:** Improper connection of the equipment-grounding conductor can result in an increased risk of electric shock. Check with a qualified electrician or serviceman if you are in doubt as to whether the product is properly grounded. Do not modify the plug provided with the product—if it will not fit the outlet, have a proper outlet installed by a qualified electrician.

A temporary adapter may be used to connect the power cord to a 2-pole receptacle as shown at the right if a properly grounded outlet is not available.

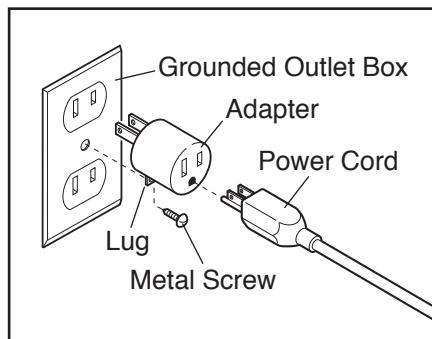

The temporary adapter should be used only until a properly grounded outlet can be installed by a qualified electrician.

The green-colored rigid ear, lug, or the like extending from the adapter must be connected to a permanent ground such as a properly grounded outlet box cover. Whenever the adapter is used, it must be held in place by a metal screw. Some 2-pole receptacle outlet box covers are not grounded. Contact a qualified electrician to determine if the outlet box cover is grounded before using an adapter.

## HOW TO MOVE THE ELLIPTICAL

**Due to the size and weight of the elliptical, moving it requires two persons.** Stand in front of the elliptical, hold the upright, and place one foot against one of the wheels. Pull on the upright and have a second person lift the handle on the ramp until the elliptical will roll on the wheels. Carefully move the elliptical to the desired location, and then lower it to the floor.

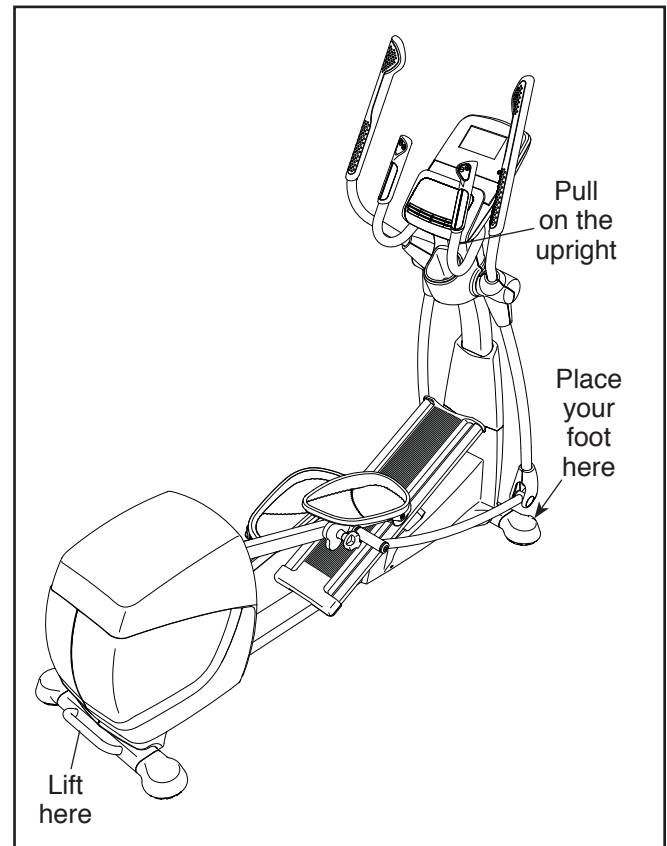

## HOW TO ADJUST THE POSITIONS OF THE PEDALS

Each pedal can be adjusted to several positions. To adjust each pedal, simply turn the pedal knob beneath the pedal. **Make sure to adjust both pedals to the same position.**

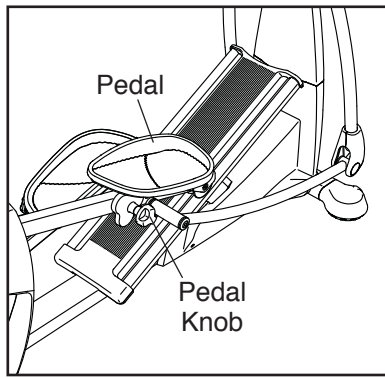

## HOW TO LEVEL THE ELLIPTICAL

If the elliptical rocks slightly on your floor during use, turn one or both of the leveling feet beneath the rear stabilizer until the rocking motion is eliminated.

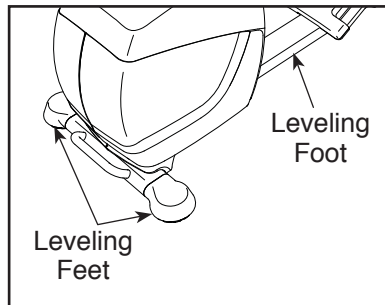

If the frame of the elliptical flexes during use, turn the leveling foot under the center of the frame until the flexing is eliminated.

## HOW TO EXERCISE ON THE ELLIPTICAL

To mount the elliptical, hold the upper body arms or the handlebars and step onto the pedal that is in the lowest position. Next, step onto the other pedal. Push the pedals until they begin to move with a continuous motion.

**Note: The pedal arms can turn in either direction. It is recommended that you turn the pedal arms in the direction shown by the arrow; however, for variety, you can turn the pedal arms in the opposite direction.**

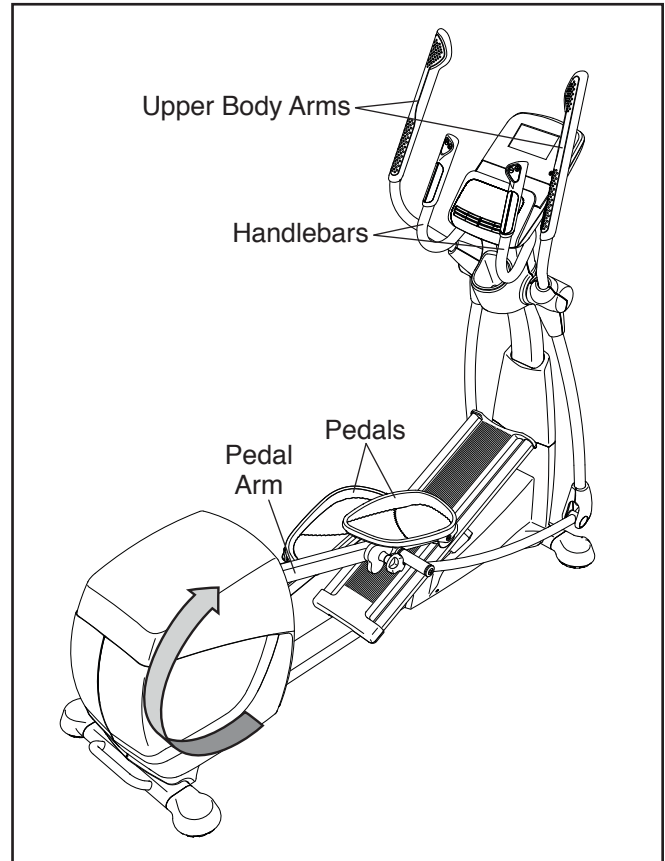

To dismount the elliptical, wait until the pedals come to a complete stop. **Note: The elliptical does not have a free wheel; the pedals will continue to move until the flywheel stops.** When the pedals are stationary, step off the highest pedal first. Then, step off the lowest pedal.

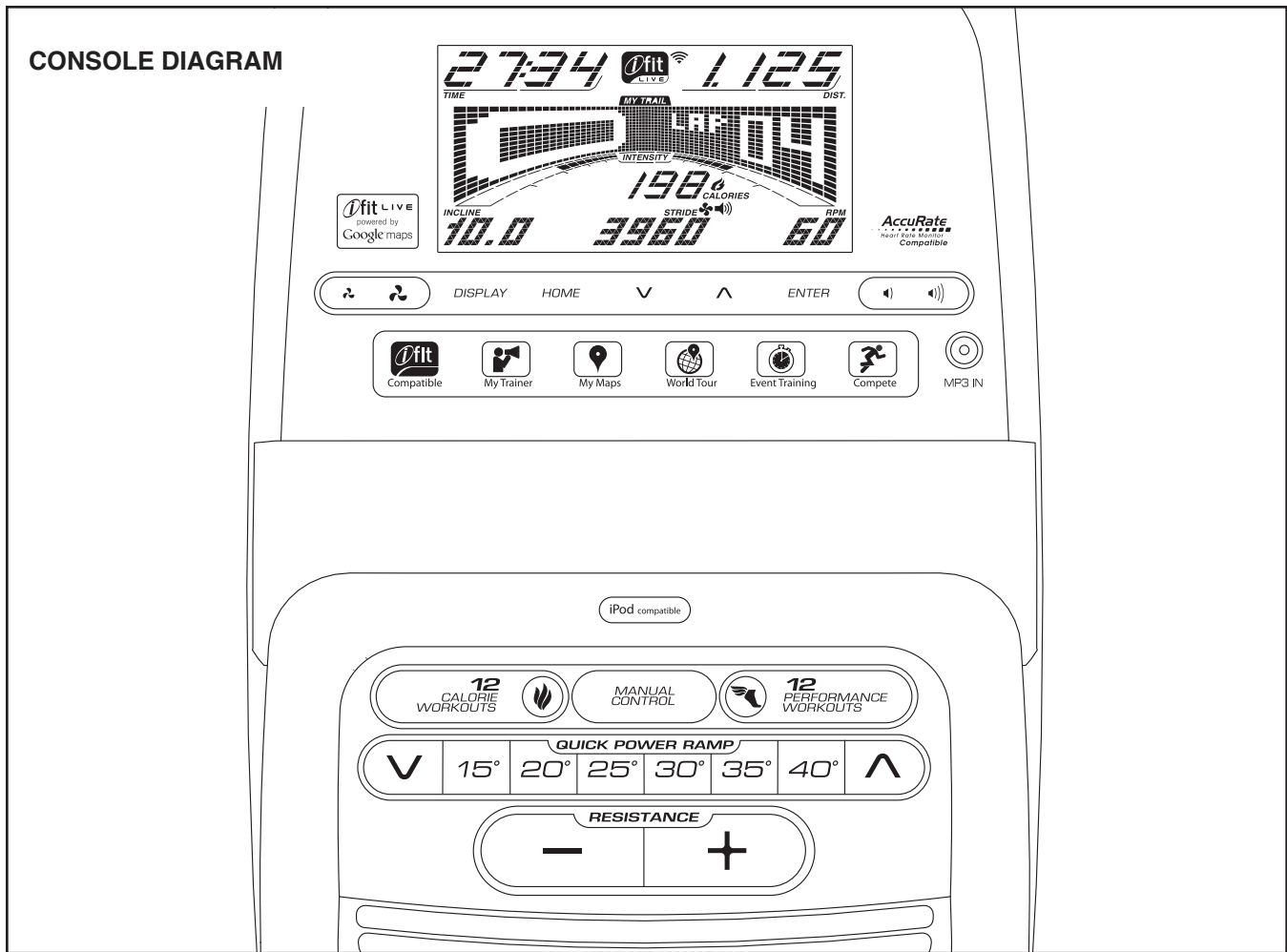

## FEATURES OF THE CONSOLE

The advanced console offers an array of features designed to make your workouts more effective and enjoyable.

When you use the manual mode of the console, you can change the resistance of the pedals and the incline of the ramp with the touch of a button. While you exercise, the console will display continuous exercise feedback. You can also measure your heart rate using the handgrip heart rate monitor or an optional chest heart rate monitor.

In addition, the console offers twenty-four preset workouts—twelve calorie workouts and twelve performance workouts. Each workout automatically changes the resistance of the pedals and the incline of the ramp and prompts you to vary your pedaling pace as it guides you through an effective workout.

The console also features revolutionary iFit Live technology that enables the console to communicate with your wireless network through an optional iFit Live module. With the iFit Live mode, you can download personalized workouts, create your own workouts, track your workout results, race against other runners, and access many other features. **To purchase an iFit Live module at any time, go to [www.iFit.com](http://www.iFit.com) or call the telephone number on the front cover of this manual.**

You can even connect your MP3 player or CD player to the console sound system and listen to your favorite music or audio books while you exercise.

**To turn on the power**, see page 17. **To use the manual mode**, see page 17. **To use a preset workout**, see page 20. **To use an iFit Live workout**, see page 21. **To use the sound system**, see page 22. **To change console settings**, see page 23.

Note: If there is a sheet of plastic on the display, remove the plastic.



## HOW TO TURN ON THE POWER

**IMPORTANT:** If the elliptical has been exposed to cold temperatures, allow it to warm to room temperature before turning on the power. If you do not do this, you may damage the console displays or other electrical components.

Plug in the power cord (see HOW TO PLUG IN THE POWER CORD on page 14). Next, locate the power switch on the frame near the power cord. Press the power switch to the reset position.

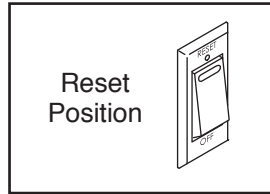

The display will then light and the console will be ready for use.

**Note:** When you turn on the power for the first time, the ramp will calibrate automatically. The ramp will move upward and downward as it calibrates. When the ramp stops moving, the ramp is calibrated.

**IMPORTANT:** If the ramp does not calibrate automatically, see HOW TO CALIBRATE THE RAMP on page 24 and manually calibrate the ramp.

## HOW TO USE THE MANUAL MODE

1. **Begin pedaling or press any button on the console to turn on the console.**

See HOW TO TURN ON THE POWER at the left.

2. **Select the manual mode.**

Press the Manual Control button on the console to select the manual mode.

If a wireless iFit Live module is not inserted into the console and connected to iFit Live, the manual mode will be selected automatically.

3. **Change the resistance of the pedals and the incline of the ramp as desired.**

As you pedal, change the resistance of the pedals by pressing the Resistance increase and decrease buttons located on the console or on the right handlebar.

**Note:** After you press a button, it will take a moment for the pedals to reach the selected resistance level.

To vary the motion of the pedals, you can change the incline of the ramp. To change the incline, press one of the numbered Quick Power Ramp buttons or press the Quick Power Ramp increase and decrease buttons located on the console or on the left handlebar.

**Note:** After you press a button, it will take a moment for the ramp to reach the selected incline level.

#### 4. Follow your progress with the display.

The display can show the following workout information:

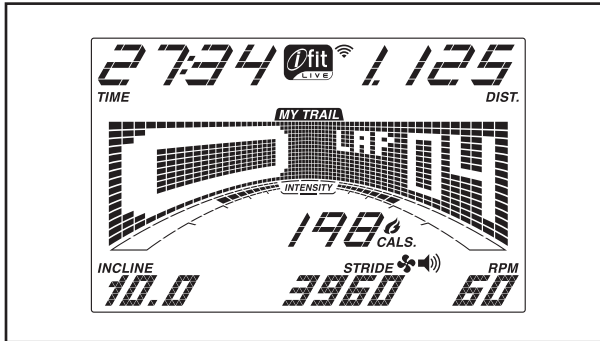

**Calories (Cals.)**—This display mode will show the approximate number of calories you have burned.

**Calories per Hour (Cals./Hr)**—This display mode will show the approximate number of calories you are burning per hour.

**Distance (Dist.)**—This display mode will show the distance that you have pedaled in miles or kilometers.

**Incline**—This display mode will show the incline level of the ramp for a few seconds each time the incline level changes.

**Pulse**—This display mode will show your heart rate when you use the handgrip heart rate monitor or an optional chest heart rate monitor (see step 5 on page 19).

**Resistance (Resist.)**—This display mode will show the resistance level of the pedals for a few seconds each time the resistance level changes.

**RPM**—This display mode will show your pedaling speed in revolutions per minute (rpm).

**Stride**—This display mode will show the total number of strides you have pedaled.

**Time**—When the manual mode is selected, this display mode will show the elapsed time. When a workout is selected, this display mode will show the time remaining in the workout.

The matrix offers several display tabs. Press the Display button until the desired tab is shown. You can also press the increase and decrease buttons next to the Enter button.

**Incline**—This tab will show a profile of the incline settings of the workout. A new segment will appear at the end of each minute.

**Speed**—This tab will show a profile of the speed settings of the workout. A new segment will appear at the end of each minute.

**My Trail**—This tab will show a track that represents 1/4 mile (400 m). As you exercise, the flashing rectangle will show your progress. The My Trail tab will also show the number of laps you complete.

**Calorie**—This tab will show the approximate amount of calories you have burned. The height of each segment represents the amount of calories burned during that segment.

As you exercise, the workout intensity level bar will indicate the approximate intensity level of your exercise.

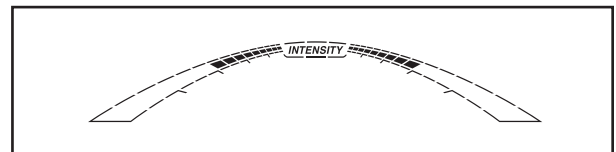

Press the Home button to return to the default menu (see HOW TO CHANGE CONSOLE SETTINGS on page 23 to set the default menu). If necessary, press the Home button again.

When a wireless iFit Live module is connected, the wireless symbol at the top of the display will show the strength of your wireless signal. Four arcs indicate full signal strength.



To exit the manual mode or a workout, press the Home button. If necessary, press the Home button again.

Change the volume level of the console by pressing the Volume increase and decrease buttons.

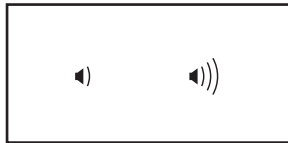

### 5. Measure your heart rate if desired.

You can measure your heart rate using either the handgrip heart rate monitor or the optional chest heart rate monitor (see page 22 for information about the optional chest heart rate monitor).

**If there are sheets of plastic on the metal contacts on the handgrip heart rate monitor, remove the plastic.** To measure your heart rate, hold the handgrip heart rate monitor with your palms resting against the contacts. **Avoid moving your hands or gripping the contacts tightly.**

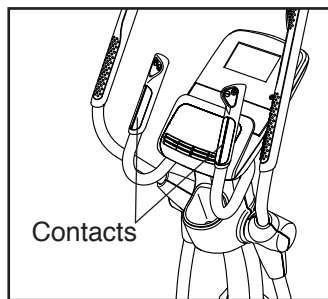

When your pulse is detected, a heart symbol will flash in the display each time your heart beats, one or two dashes will appear, and then your heart rate will be shown. For the most accurate heart rate reading, hold the contacts for at least 15 seconds.

If the display does not show your heart rate, make sure that your hands are positioned as described. Be careful not to move your hands excessively or to squeeze the contacts tightly. For optimal performance, clean the contacts using a soft cloth; **never use alcohol, abrasives, or chemicals to clean the contacts.**

### 6. Turn on the fan if desired.

The fan has low and high speed settings. Press the Fan increase and decrease buttons repeatedly to select a fan speed or to turn off the fan.

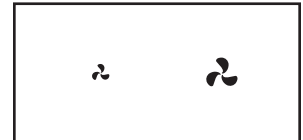

Note: If the pedals do not move for about thirty seconds, the fan will turn off automatically.

### 7. When you are finished exercising, unplug the power cord.

If the pedals do not move for several seconds, a tone will sound and the console will pause.

If the pedals do not move for several minutes and the buttons are not pressed, the console will turn off and the display will be reset.

When you are finished exercising, press the power switch to the off position and unplug the power cord. **IMPORTANT: If you do not do this, the electrical components on the elliptical may wear prematurely.**

## HOW TO USE A PRESET WORKOUT

### 1. Begin pedaling or press any button on the console to turn on the console.

See HOW TO TURN ON THE POWER on page 17.

### 2. Select a preset workout.

To select a preset workout, press the 12 Calorie Workouts or the 12 Performance Workouts button repeatedly until the desired workout appears in the display.

When you select a preset workout, the display will show the duration of the workout and the name of the workout. A profile of the speed settings of the workout will appear in the matrix.

The display will also show the maximum pedaling speed (rpm), the maximum resistance level, and the maximum ramp level.

### 3. Begin pedaling to start the workout.

Each workout is divided into one-minute segments. One resistance level, one ramp incline level, and one target rpm (speed) are programmed for each segment. Note: The same resistance level, ramp incline level, and/or target rpm may be programmed for consecutive segments.

The resistance level, the ramp incline level, and the target rpm for the first segment will appear in the matrix.

During the workout, the profiles on the speed and incline tabs will show your progress. The flashing segment of the profile represents the current segment of the workout. The height of the flashing segment indicates the target speed or the incline level for the current segment.

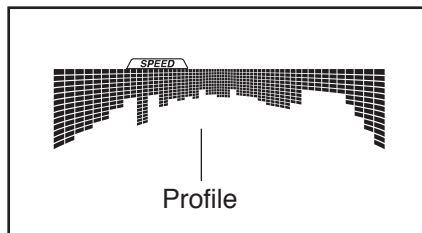

At the end of each segment of the workout, a series of tones will sound and the next segment of the profile will begin to flash. If a different resistance level, ramp incline level, and/or target rpm is programmed for the next segment, the resistance level, ramp incline level, and/or target rpm will appear in the display for a few seconds to alert you. The resistance of the pedals and the incline level of the ramp will then change.

As you exercise, you will be prompted to keep your pedaling speed near the target rpm for the current segment. When an upward-pointing arrow appears in the display, increase your pace. When a downward-pointing arrow appears, decrease your pace. When no arrow appears, maintain your current pace.

**IMPORTANT: The target rpm is intended only to provide motivation. Your actual pedaling speed may be slower than the target rpm. Make sure to pedal at a speed that is comfortable for you.**

If the resistance level or incline level for the current segment is too high or too low, you can manually override the setting by pressing the Resistance buttons or the Quick Power Ramp buttons.

**IMPORTANT: When the current segment of the workout ends, the pedals will automatically adjust to the resistance level programmed for the next segment and the ramp will automatically adjust to the incline level programmed for the next segment.**

The workout will continue in this way until the last segment ends. To stop the workout at any time, stop pedaling. The time will flash in the display. To resume the workout, simply resume pedaling.

### 4. Follow your progress with the display.

See step 4 on page 18.

### 5. Measure your heart rate if desired.

See step 5 on page 19.

### 6. Turn on the fan if desired.

See step 6 on page 19.

### 7. When you are finished exercising, unplug the power cord.

See step 7 on page 19.

## HOW TO USE AN iFIT LIVE WORKOUT

You must have an iFit Live module to use an iFit Live workout.

**To purchase an iFit Live module at any time, go to [www.iFit.com](http://www.iFit.com) or call the telephone number on the front cover of this manual.**

Note: To use an iFit Live module, you must have access to a computer with an internet connection and a USB port. You will also need an iFit.com membership. To use a wireless iFit Live module, you must also have your own wireless network including an 802.11b router with SSID broadcast enabled (hidden networks are not supported).

**IMPORTANT: To satisfy exposure compliance requirements, the antenna and transmitter in the iFit Live module must be at least 8 in. (20 cm) from all persons and must not be near or connected to any other antenna or transmitter.**

### 1. Begin pedaling or press any button on the console to turn on the console.

See HOW TO TURN ON THE POWER on page 17.

### 2. Make sure that the iFit Live module is inserted in the console.

To use an iFit Live workout, make sure that the iFit Live module is inserted in the console.

### 3. Select the iFit Live mode.

To select the iFit Live mode, press the iFit Live button.

### 4. Select a user.

If more than one user is registered with your iFit.com membership, you can switch users in the iFit Live main screen. Press the increase and decrease buttons next to the Enter button to select a user.

### 5. Select an iFit Live workout.

To select an iFit Live workout, press one of the iFit Live buttons. Note: Before some workouts will download, you must go to [www.iFit.com](http://www.iFit.com) and add them to your schedule.

Press the iFit Live button to download the next workout in your schedule. Press the My Trainer button, the My Maps button, the World Tour button, or the Event Training button to download the next workout of that type in your schedule. Press the Compete button to compete in a race that you have previously scheduled. **For more information about the iFit Live workouts, please see [www.iFit.com](http://www.iFit.com).**

When you select an iFit Live workout, the display will show the duration of the workout and the approximate number of calories you will burn. The display may also show the name of the workout. If you select a competition workout, the display may count down to the beginning of the race.

### 6. Start the workout.

See step 3 on page 20.

During some workouts, the voice of a personal trainer will guide you through your workout. You can select an audio setting for your personal trainer (see HOW TO CHANGE CONSOLE SETTINGS on page 23).

To stop the workout at any time, stop pedaling. The time will flash in the display. To resume the workout, simply resume pedaling.

## 7. Follow your progress with the display.

See step 4 on page 18.

The My Trail tab will show a map of the trail you are walking or running or it will show a track and the number of laps you complete.

During a competition workout, the Competition tab will show your progress in the race. As you race, the top line in the matrix will show how much of the race you have completed. The other lines will show other competitors. The end of the matrix represents the end of the race.

## 8. Measure your heart rate if desired.

See step 5 on page 19.

## 9. Turn on the fan if desired.

See step 6 on page 19.

## 10. When you are finished exercising, unplug the power cord.

See step 7 on page 19.

For more information about the iFit Live mode, go to [www.iFit.com](http://www.iFit.com).

## HOW TO USE THE SOUND SYSTEM

To play music or audio books through the console sound system while you exercise, plug the included audio cable into the jack on the console and into a jack on your MP3 player or CD player; **make sure that the audio cable is fully plugged in.**

Next, press the play button on your MP3 player or CD player. Adjust the volume level using the Volume increase and decrease buttons on the console or the volume control on your MP3 player or CD player.

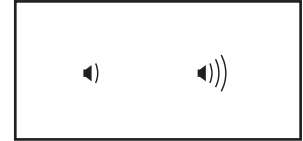

## THE OPTIONAL CHEST HEART RATE MONITOR

Whether your goal is to burn fat or to strengthen your cardiovascular system, the key to achieving the best results is to maintain the proper heart rate during your workouts. The optional chest heart rate monitor will enable you to continuously monitor your heart rate while you exercise, helping you to reach your personal fitness goals. **To purchase a chest heart rate monitor, please see the front cover of this manual.**

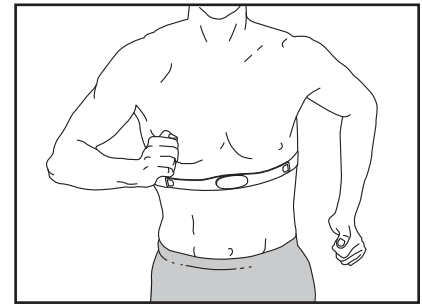

---

## FCC INFORMATION

This equipment has been tested and found to comply with the limits for a Class B digital device, pursuant to part 15 of the FCC Rules. These limits are designed to provide reasonable protection against harmful interference in a residential installation. This equipment generates, uses, and can radiate radio frequency energy and, if not installed and used in accordance with the instructions, may cause harmful interference to radio communications. However, there is no guarantee that interference will not occur in a particular installation. If this equipment does cause harmful interference to radio or television reception, which can be determined by turning the equipment off and on, try to correct the interference by one or more of the following measures:

- Reorient or relocate the receiving antenna.
- Increase the separation between the equipment and the receiver.
- Connect the equipment into an outlet on a circuit different from that to which the receiver is connected.
- Consult the dealer or an experienced radio/TV technician for help.

**FCC CAUTION: To assure continued compliance, use only shielded interface cables when connecting to computer or peripheral devices. Changes or modifications not expressly approved by the party responsible for compliance could void the user's authority to operate this equipment.**

## HOW TO CHANGE CONSOLE SETTINGS

The console features a user mode that allows you to view usage information, select a unit of measurement, and adjust the contrast level of the display.

When an iFit Live module is connected to the console, you can also use the information mode to choose an audio setting for the voice of the personal trainer, set a default menu, check the status of the iFit Live module, and check for downloads.

### 1. Select the information mode.

To select the information mode, press and hold down the Display button for a few seconds until the information mode appears in the display.

### 2. View usage information.

The display will show the total number of hours that the elliptical has been used. The display will also show the total distance (in miles or kilometers) that has been pedaled on the elliptical.

### 3. Select a unit of measurement if desired.

The word ENGLISH for English miles or the word METRIC for metric kilometers will appear in the display to indicate the currently selected unit of measurement.

To change the unit of measurement, press the Enter button repeatedly to select the desired unit of measurement.

### 4. Determine if an iFit Live module is connected to the console.

If an iFit Live module is connected to the console, the display will show the words WIFI MODULE or USB MODULE.

If no module is connected, the display will show the words NO IFIT MODULE. If no module is connected, steps 6 to 9 are not applicable.

### 5. Adjust the contrast level of the display if desired.

Press the decrease button to view the contrast level. The currently selected contrast level will appear in the display. Press the Quick Power Ramp increase and decrease buttons to adjust the contrast level.

### 6. Select an audio setting for the voice of the personal trainer if desired.

Press the decrease button to view the audio setting for the voice of the personal trainer. The currently selected audio setting for the voice of the personal trainer will appear in the display.

To change the audio setting, press the Enter button repeatedly to turn the voice of the personal trainer ON or OFF.

### 7. Set the default menu if desired.

Press the decrease button to view the default menu setting. The default menu is the menu that will appear when you turn on the console. Press the Enter button repeatedly to select the manual mode main menu or the iFit Live menu as the default menu.

### 8. Check the status of the iFit Live module if desired.

Press the decrease button to view the iFit Live status display. The words CHECK WIFI STATUS or CHECK USB STATUS will appear in the display.

Then, press the Enter button. After a few seconds, the status of the iFit Live module will appear in the display. To exit this display, press and hold down the Display button for a few seconds.

### 9. Check for downloads if desired.

Press the decrease button to view the downloads display. The words SEND/RECEIVE DATA will appear in the display.

Then, press the Enter button. The console will then check for iFit Live workouts and firmware downloads.

### 10. Exit the information mode.

Press the Display button to exit the information mode.

# MAINTENANCE AND TROUBLESHOOTING

Inspect and tighten all parts of the elliptical regularly. Replace any worn parts immediately.

To clean the elliptical, use a damp cloth and a small amount of mild soap. **IMPORTANT: To avoid damage to the console, keep liquids away from the console and keep the console out of direct sunlight.**

## CONSOLE TROUBLESHOOTING

If the console does not display your heart rate when you hold the handgrip heart rate monitor, or if the displayed heart rate appears to be too high or too low, see step 5 on page 19.

## HOW TO CALIBRATE THE RAMP

If the ramp is not functioning properly, the ramp may need to be calibrated. To calibrate the ramp, press and hold the 12 Calorie Workouts button for several seconds until the test mode appears in the display.

Press the 12 Calorie Workouts button again. Then, press the Quick Power Ramp increase or decrease button to calibrate the ramp. The ramp will move upward and downward as it calibrates.

When the ramp stops moving, the ramp is calibrated. Then, press the 12 Calorie Workouts button repeatedly to exit the calibration mode.

## HOW TO GREASE THE PEDAL ARM ROLLERS

See the EXPLODED DRAWING near the end of this manual. If the Pedal Arm Rollers (51) squeak when moving on the Left and Right Tracks (16, 146), apply a small amount of white marine grease equally to each Pedal Arm Roller. Spread the grease evenly around the Pedal Arm Rollers. Pedal the elliptical until a thin film of grease is distributed along the Left and Right Tracks; then, wipe off any excess grease.

## HOW TO ADJUST THE REED SWITCH

If the console does not display correct feedback, the reed switch should be adjusted.

To adjust the reed switch, you must first remove the shield cover and center shield assembly and the pulley cover (see the instructions below).

First, remove the two indicated M4 x 16mm Screws (101) from the Center Shield (76). Next, using a flat screwdriver, release the tabs on the sides and rear of the Shield Cover (75). Then, slide the Center Shield and the Shield Cover forward.

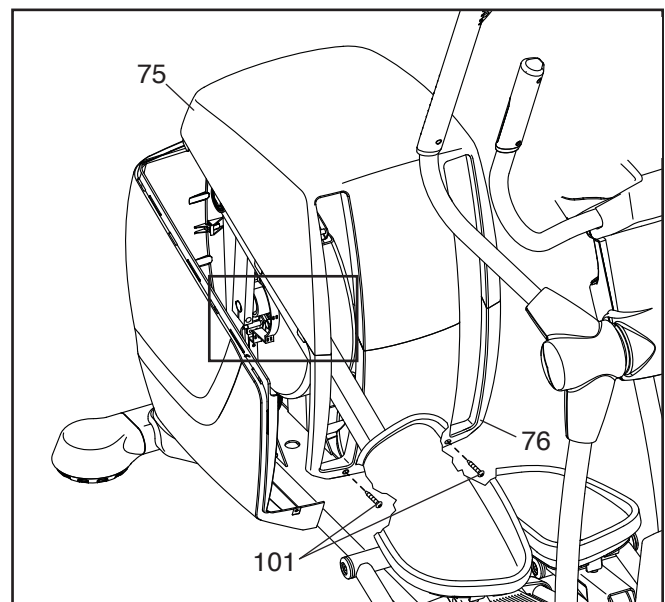

Next, see EXPLODED DRAWING A on page 29. Remove the four M4 x 16mm Screws (101) from the Pulley Cover (15), and then remove the Pulley Cover. It may be necessary to disconnect the wires (not shown) at the top of the Pulley Cover.



Locate the Reed Switch (38). Loosen, but do not remove, the two M4 x 12.7mm Flange Screws (161).

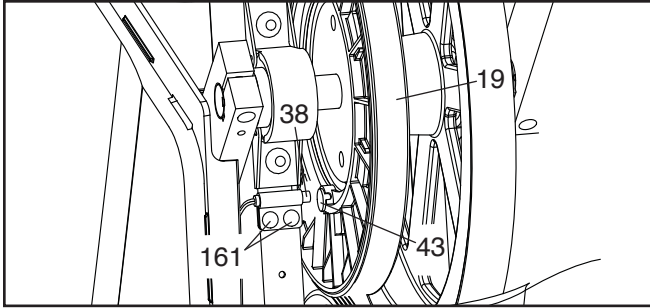

Next, rotate the Large Pulley (19) until a Magnet (43) is aligned with the Reed Switch (38). Slide the Reed Switch slightly toward or away from the Magnet. Then, retighten the M4 x 12.7mm Flange Screws (161).

Rotate the Large Pulley (19) for a moment. Repeat these actions until the console displays correct feedback.

When the reed switch is correctly adjusted, reattach the pulley cover, reconnect the wires if necessary, and reattach the shield cover and center shield assembly.

#### HOW TO ADJUST THE DRIVE BELT

If you can feel the pedals slip while you are pedaling, even when the resistance is adjusted to the highest setting, the large drive belt may need to be adjusted.

To adjust the large drive belt, you must first remove the Shield Cover (75) and the Center Shield (76) (see the instructions below).

Remove the two indicated M4 x 16mm Screws (101) from the Center Shield (76). Next, using a flat screwdriver, release the tabs on the sides and rear of the Shield Cover (75). Then, slide the Center Shield and the Shield Cover forward.

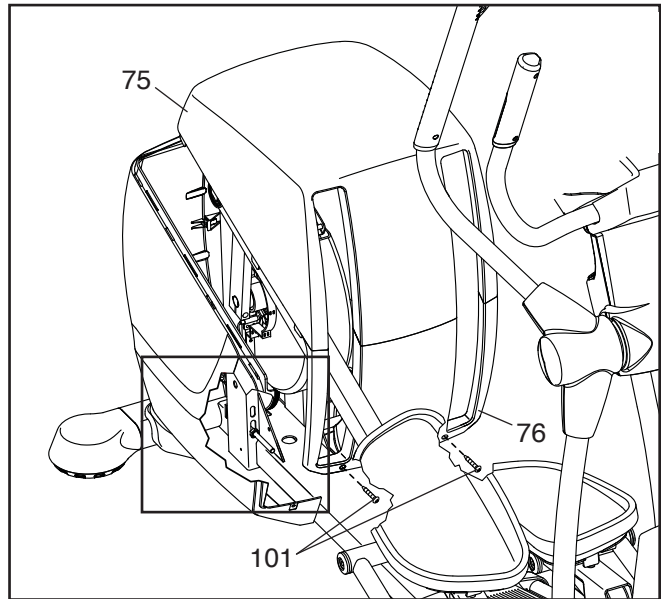

Next, tighten the M8 Nut (122) on the J-bolt (139) **one half turn**.

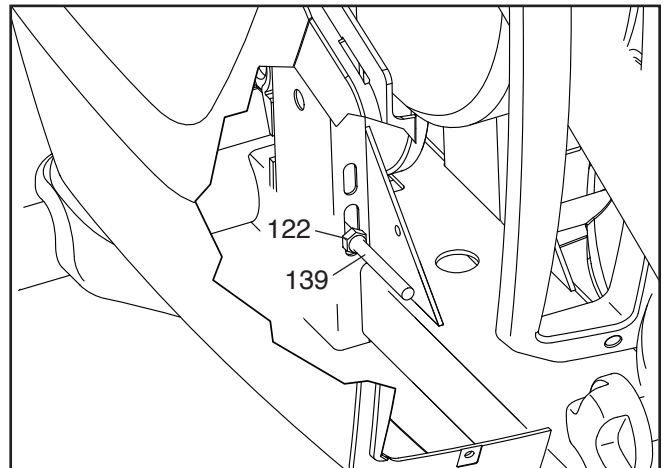

Reattach the shield cover and the center shield. If the pedals still slip while you are pedaling, repeat these steps.

**If you have a question about drive belt adjustment, see the front cover of this manual.**

# EXERCISE GUIDELINES

**⚠️ WARNING:** Before beginning this or any exercise program, consult your physician. This is especially important for persons over age 35 or persons with pre-existing health problems.

The heart rate monitor is not a medical device. Various factors may affect the accuracy of heart rate readings. The heart rate monitor is intended only as an exercise aid in determining heart rate trends in general.

These guidelines will help you to plan your exercise program. For detailed exercise information, obtain a reputable book or consult your physician. Remember, proper nutrition and adequate rest are essential for successful results.

## EXERCISE INTENSITY

Whether your goal is to burn fat or to strengthen your cardiovascular system, exercising at the proper intensity is the key to achieving results. You can use your heart rate as a guide to find the proper intensity level. The chart below shows recommended heart rates for fat burning and aerobic exercise.

165	155	145	140	130	125	115	♥
145	138	130	125	118	110	103	♥
125	120	115	110	105	95	90	♥
<hr/>							
20	30	40	50	60	70	80	

To find the proper intensity level, find your age at the bottom of the chart (ages are rounded off to the nearest ten years). The three numbers listed above your age define your “training zone.” The lowest number is the heart rate for fat burning, the middle number is the heart rate for maximum fat burning, and the highest number is the heart rate for aerobic exercise.

**Burning Fat**—To burn fat effectively, you must exercise at a low intensity level for a sustained period of time. During the first few minutes of exercise, your body uses carbohydrate calories for energy. Only after the first few minutes of exercise does your body begin to use stored fat calories for energy. If your goal is to burn fat, adjust the intensity of your exercise until your heart rate is near the lowest number in your training zone. For maximum fat burning, exercise with your heart rate near the middle number in your training zone.

**Aerobic Exercise**—If your goal is to strengthen your cardiovascular system, you must perform aerobic exercise, which is activity that requires large amounts of oxygen for prolonged periods of time. For aerobic exercise, adjust the intensity of your exercise until your heart rate is near the highest number in your training zone.

## WORKOUT GUIDELINES

**Warming Up**—Start with 5 to 10 minutes of stretching and light exercise. A warm-up increases your body temperature, heart rate, and circulation in preparation for exercise.

**Training Zone Exercise**—Exercise for 20 to 30 minutes with your heart rate in your training zone. (During the first few weeks of your exercise program, do not keep your heart rate in your training zone for longer than 20 minutes.) Breathe regularly and deeply as you exercise—never hold your breath.

**Cooling Down**—Finish with 5 to 10 minutes of stretching. Stretching increases the flexibility of your muscles and helps to prevent post-exercise problems.

## EXERCISE FREQUENCY

To maintain or improve your condition, complete three workouts each week, with at least one day of rest between workouts. After a few months of regular exercise, you may complete up to five workouts each week, if desired. Remember, the key to success is to make exercise a regular and enjoyable part of your everyday life.

# PART LIST

Model No. PFEL59911.2 R1111A

Key No.	Qty.	Description	Key No.	Qty.	Description
1	1	Frame	51	2	Pedal Arm Roller
2	2	Rear Stabilizer Tube	52	2	Ramp Arm Roller
3	1	Ramp	53	1	Ramp Arm
4	1	Upright	54	2	16mm Wave Washer
5	26	M4 x 19mm Screw	55	4	Axle Cover
6	1	Front Left Stabilizer Tube	56	12	Large Arm Bushing
7	1	Console	57	4	Large Bearing
8	1	Small Pulley	58	1	Right Pedal Arm
9	2	Small Pulley Bracket	59	1	Right Link Arm
10	1	Ramp Cover	60	1	Right Upper Body Leg
11	2	Large Pulley Bracket	61	1	Right Upper Body Arm
12	1	Left Pedal	62	1	Left Grip
13	1	Left Pedal Plate	63	1	Left Rear Shield
14	1	Right Pedal Plate	64	2	Pedal Arm Roller Axle
15	1	Pulley Cover	65	1	Right Front Arm Cover
16	1	Left Track	66	1	Right Rear Arm Cover
17	1	Left Ramp Cap	67	1	Left Front Arm Cover
18	1	Crank	68	1	Left Rear Arm Cover
19	1	Large Pulley	69	1	Right Outer Leg Cover
20	2	Crank Arm	70	1	Left Outer Leg Cover
21	6	M4 x 10mm Screw	71	1	Right Rear Shield
22	1	Idler	72	1	Left Inner Leg Cover
23	1	C-magnet	73	1	Left Front Shield
24	2	Ramp Bushing	74	1	Right Front Shield
25	1	Resistance Motor	75	1	Shield Cover
26	1	Resistance Rod	76	1	Center Shield
27	1	Resistance Disc	77	4	M8 x 92mm Bolt
28	1	Flywheel	78	2	Key
29	1	Right Grip	79	1	Front Console Cover
30	2	Rear Upper Cap	80	1	Rear Console Cover
31	1	Incline Motor	81	1	Upright Cover
32	1	Front Right Upper Cap	82	18	M8 x 23mm Button Screw
33	2	Large Leveling Foot	83	1	Right Inner Leg Cover
34	2	Wheel	84	2	M10 x 70mm Screw
35	1	Long Axle	85	2	M5 x 16mm Button Screw
36	2	Upright Bushing	86	2	M10 x 58mm Button Bolt
37	1	Accessory Tray	87	4	M10 x 94mm Bolt
38	1	Reed Switch/Wire	88	1	Small Pulley Axle
39	1	Reed Switch Clamp	89	1	Idler Screw
40	1	Motor Controller	90	12	M6 Washer
41	6	Small Bearing	91	22	M10 x 20mm Screw
42	8	Flywheel Snap Ring	92	1	M6 x 54mm Bolt
43	2	Magnet	93	4	M4 x 12mm Flange Screw
44	1	Left Pedal Arm	94	1	M6 Locknut
45	1	Left Link Arm	95	8	M8 x 18mm Screw
46	1	Left Upper Body Leg	96	6	M8 x 43mm Button Bolt
47	1	Left Upper Body Arm	97	18	M8 x 22mm Washer
48	2	Pedal Spring	98	2	Ramp Roller Snap Ring
49	1	Right Pedal	99	1	C-magnet Snap Ring
50	2	Front Lower Cap	100	4	Small Arm Bushing

Key No.	Qty.	Description	Key No.	Qty.	Description
101	40	M4 x 16mm Screw	138	2	Small Pulley Snap Ring
102	6	M8 Jam Nut	139	1	J-bolt
103	12	M6 x 16mm Screw	140	2	Ramp Arm Bushing
104	1	Power Switch	141	2	Ramp Arm Clamp
105	20	M10 Split Washer	142	1	M10 x 45mm Bolt
106	2	Shield Mount	143	1	M10 x 35mm Bolt
107	6	M4 x 12mm TZP Screw	144	2	M10 Square Nut
108	1	Right Sensor Wire	145	1	Front Right Stabilizer Tube
109	2	M8 x 45mm Button Bolt	146	1	Right Track
110	1	Left Sensor Wire	147	1	Right Ramp Cap
111	1	Lower Wire	148	4	M4 x 12mm Screw
112	1	Audio Cable	149	2	Short Axle
113	1	Large Drive Belt	150	1	Small Drive Belt
114	1	Left Pulse Grip/Controller	151	2	Pedal Knob Screw
115	1	Front Left Upper Cap	152	1	Upper Wire
116	1	Right Pulse Grip/Controller	153	4	M10 x 22mm Washer
117	8	M8 Split Washer	154	2	Spring Spacer
118	5	M8 x 18mm Washer	155	1	Strain Relief
119	2	Medium Axle	156	4	Stand-off
120	1	Ramp Axle	157	2	Wire Clamp
121	4	Frame Bushing	158	2	Grommet
122	11	M8 Nut	159	2	M4 x 25mm Screw
123	2	Pedal Knob	160	2	Shield Clip
124	1	Left Pedal Bracket	161	2	M4 x 12.7mm Flange Screw
125	1	Left Bracket Cover	162	1	Extension Wire
126	1	M3.5 x 12mm Flat Head Screw	*	–	Short Jumper Wire
127	2	Adjustment Nut	*	–	Long Jumper Wire
128	1	M5 x 7mm Screw	*	–	Ground Wire
129	1	Resistance Bracket	*	–	15" Wire Harness
130	1	M5 Washer	*	–	25" Wire Harness
131	1	Right Bracket Cover	*	–	80" Wire Harness
132	2	Pedal Axle	*	–	90" Wire Harness
133	1	Right Pedal Bracket	*	–	Reed Switch Extension Wire
134	2	M10 x 25mm Washer	*	–	Assembly Tool
135	6	M10 Locknut	*	–	Grease Packet
136	1	Small Leveling Foot	*	–	User's Manual
137	1	Power Cord			

Note: Specifications are subject to change without notice. For information about ordering replacement parts, see the back cover of this manual. \*These parts are not illustrated.

# EXPLODED DRAWING A

Model No. PFEL59911.2 R1111A

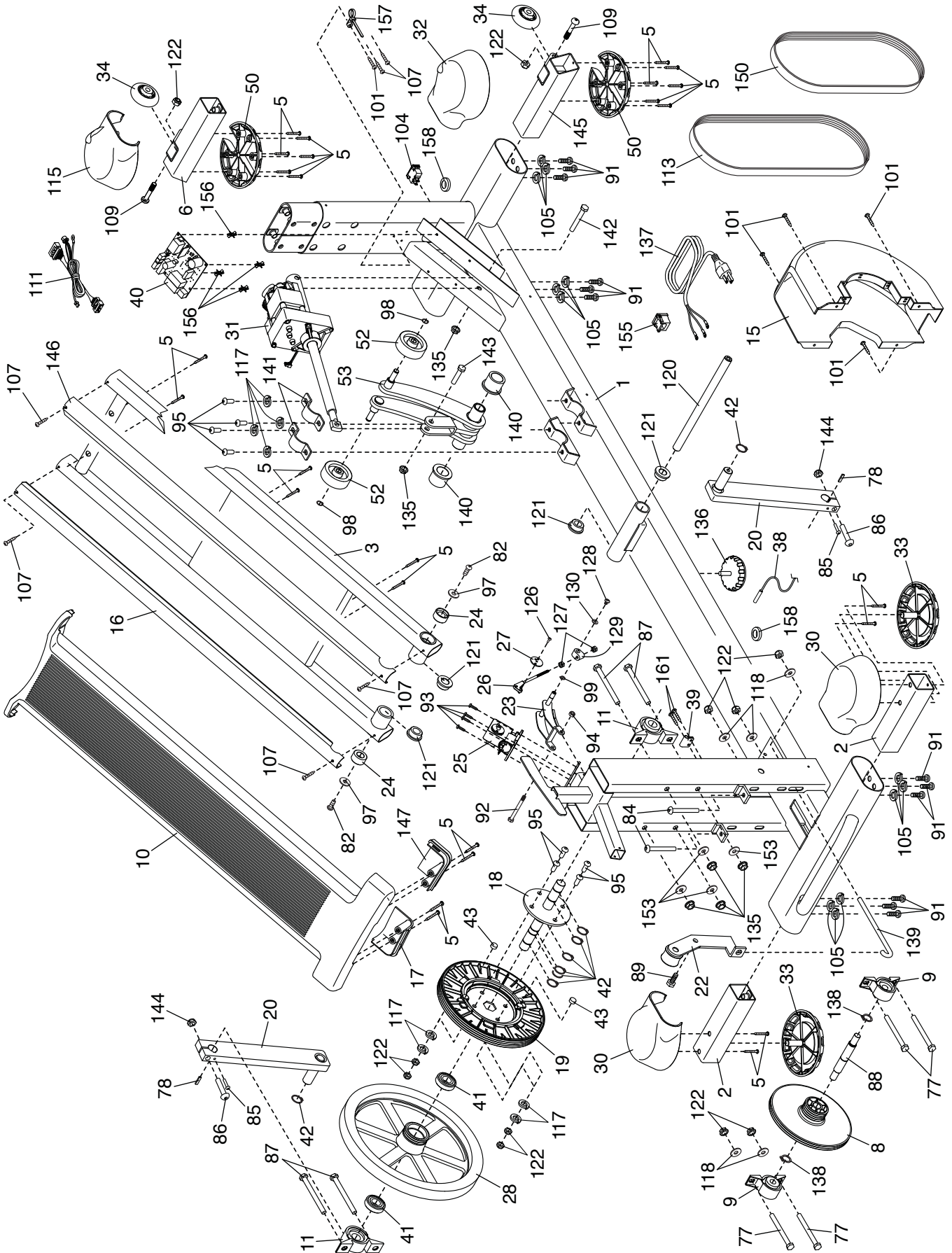

# EXPLODED DRAWING B

Model No. PFEL59911.2 R1111A

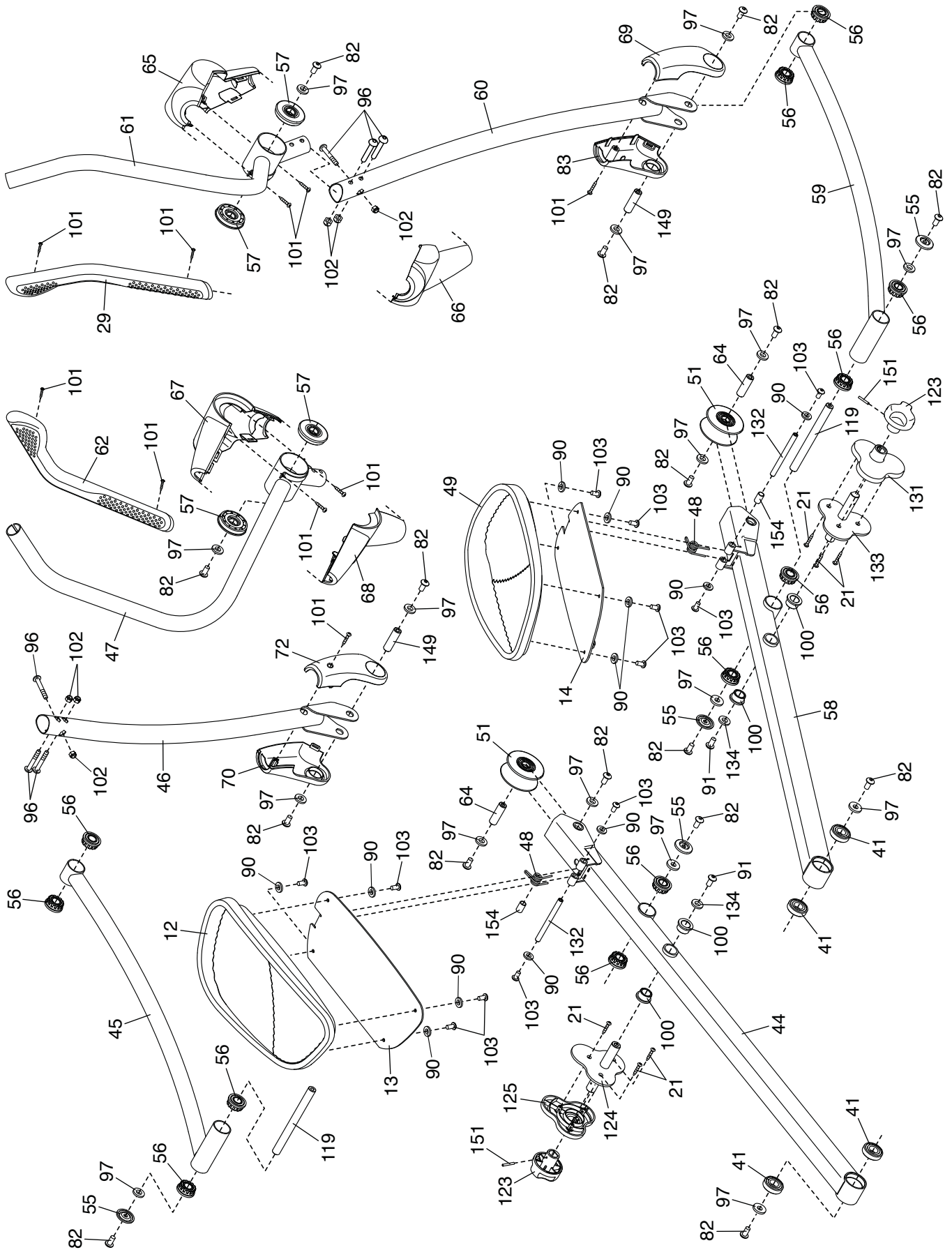



---

# ORDERING REPLACEMENT PARTS

To order replacement parts, please see the front cover of this manual. To help us assist you, be prepared to provide the following information when contacting us:

- the model number and serial number of the product (see the front cover of this manual)
- the name of the product (see the front cover of this manual)
- the key number and description of the replacement part(s) (see the PART LIST and the EXPLODED DRAWING near the end of this manual)

## LIMITED WARRANTY

**IMPORTANT: You must register this product within 30 days of the purchase date to avoid added fees for service needed under warranty. Go to [www.proformservice.com/registration](http://www.proformservice.com/registration).**

ICON Health & Fitness, Inc. (ICON) warrants this product to be free from defects in workmanship and material, under normal use and service conditions. The frame is warranted for a lifetime. Parts are warranted for three (3) years from the date of purchase. Labor is warranted for one (1) year from the date of purchase.

This warranty extends only to the original purchaser (customer). ICON's obligation under this warranty is limited to repairing or replacing, at ICON's option, the product through one of its authorized service centers. All repairs for which warranty claims are made must be preauthorized by ICON. If the product is shipped to a service center, freight charges to and from the service center will be the customer's responsibility. If replacement parts are shipped while the product is under warranty, the customer will be responsible for a minimal handling charge. For in-home service, the customer will be responsible for a minimal trip charge. This warranty does not extend to freight damage to the product. This warranty will automatically be voided if the product is used as a store display model, if the product is purchased or transported outside the USA, if all instructions in this manual are not followed, if the product is abused or improperly or abnormally used, or if the product is used for commercial or rental purposes. No other warranty beyond that specifically set forth above is authorized by ICON.

ICON is not responsible or liable for indirect, special, or consequential damages arising out of or in connection with the use or performance of the product; damages with respect to any economic loss, loss of property, loss of revenues or profits, loss of enjoyment or use, or costs of removal or installation; or other consequential damages of any kind. Some states do not allow the exclusion or limitation of incidental or consequential damages. Accordingly, the above limitation may not apply to the customer.

The warranty extended hereunder is in lieu of any and all other warranties, and any implied warranties of merchantability or fitness for a particular purpose are limited in their scope and duration to the terms set forth herein. Some states do not allow limitations on how long an implied warranty lasts. Accordingly, the above limitation may not apply to the customer.

This warranty provides specific legal rights; the customer may have other rights that vary from state to state.

**ICON Health & Fitness, Inc., 1500 S. 1000 W., Logan, UT 84321-9813**