

PRO-FORM[®] 385ex

PERFORMANCE TREADMILL

Model No. PFTL38581

Serial No. _____

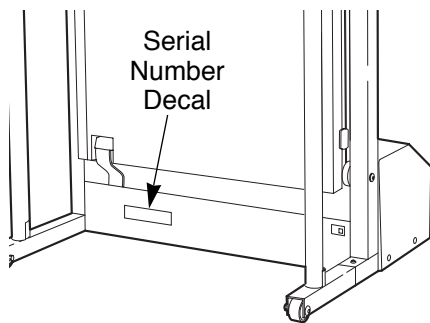

USER'S MANUAL

QUESTIONS?

As a manufacturer, we are committed to providing complete customer satisfaction. If you have questions, or if there are missing or damaged parts, we will guarantee complete satisfaction through direct assistance from our factory.

TO AVOID UNNECESSARY DELAYS, PLEASE CALL DIRECT TO OUR TOLL-FREE CUSTOMER HOT LINE. The trained technicians on our Customer Hot Line will provide immediate assistance, free of charge to you.

CUSTOMER HOT LINE:

1-800-999-3756

Mon.-Fri., 6 a.m.-6 p.m. MST

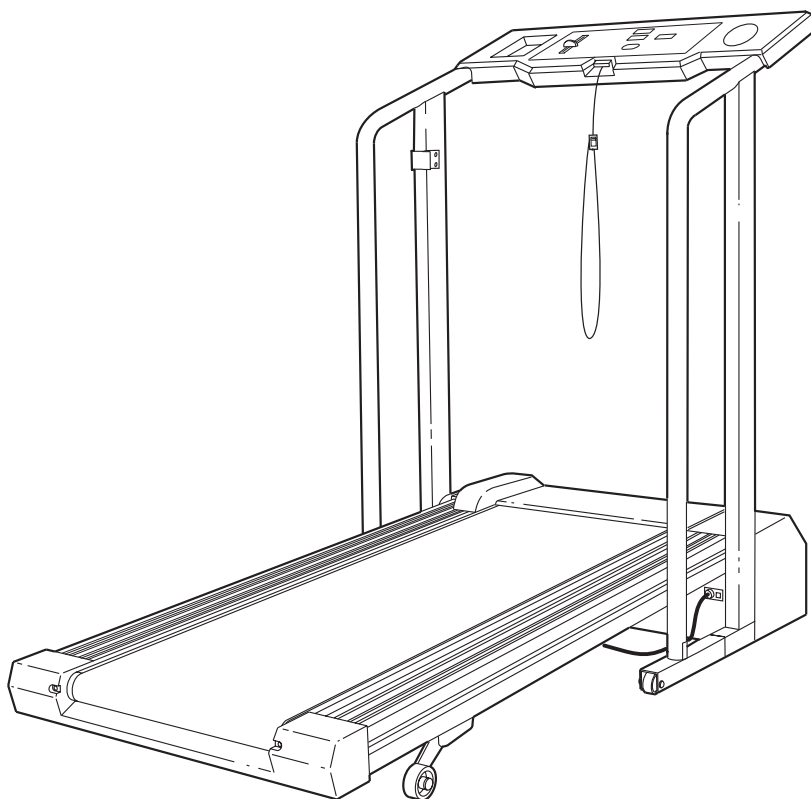

CAUTION

Read all precautions and instructions in this manual before using this equipment. Save this manual for future reference.



Visit our website at

www.proform.com

new products, prizes,
fitness tips, and much more!

TABLE OF CONTENTS

| | |
|------------------------------------|------------|
| IMPORTANT PRECAUTIONS | 2 |
| BEFORE YOU BEGIN | 4 |
| ASSEMBLY | 5 |
| OPERATION AND ADJUSTMENT | 7 |
| HOW TO FOLD AND MOVE THE TREADMILL | 10 |
| MAINTENANCE AND TROUBLE-SHOOTING | 12 |
| CONDITIONING GUIDELINES | 14 |
| ORDERING REPLACEMENT PARTS | Back Cover |
| LIMITED WARRANTY | Back Cover |

Note: An EXPLODED DRAWING and PART LIST are attached to the center of this manual. Please save them for future reference.

IMPORTANT PRECAUTIONS

⚠ WARNING: To reduce the risk of burns, fire, electric shock, or injury to persons, read the following important precautions and information before operating the treadmill.

1. It is the responsibility of the owner to ensure that all users of this treadmill are adequately informed of all warnings and precautions.
2. Use the treadmill only as described in this manual.
3. Place the treadmill on a level surface, with at least eight feet of clearance behind it. Do not place the treadmill on any surface that blocks air openings. To protect the floor or carpet from damage, place a mat under the treadmill.
4. Keep the treadmill indoors, away from moisture and dust. Do not put the treadmill in a garage or covered patio, or near water.
5. Do not operate the treadmill where aerosol products are used or where oxygen is being administered.
6. Keep children under the age of 12 and pets away from the treadmill at all times.
7. The treadmill should not be used by persons weighing more than 250 pounds.
8. Never allow more than one person on the treadmill at a time.
9. Wear appropriate exercise clothing when using the treadmill. Do not wear loose clothing that could become caught in the treadmill. Athletic support clothes are recommended for both men and women. Always wear athletic shoes. Never use the treadmill with bare feet, wearing only stockings, or in sandals.
10. When connecting the power cord (see page 7), plug the power cord into a surge protector (not included) and plug the surge protector into a grounded circuit capable of carrying 15 or more amps. No other appliance should be on the same circuit. Do not use an extension cord.
11. Use only a UL-listed surge protector, rated at 15 amps, with a 14-gauge cord of five feet or less in length. Do not use an extension cord.
12. Keep the power cord and the surge protector away from heated surfaces.
13. Never move the walking belt while the power is turned off. Do not operate the treadmill if the power cord or plug is damaged, or if the treadmill is not working properly. (See BEFORE YOU BEGIN on page 4 if the treadmill is not working properly.)

14. Never start the treadmill while you are standing on the walking belt. Always hold the handrails while using the treadmill.
15. The treadmill is capable of high speeds. Adjust the speed in small increments to avoid sudden jumps in speed.
16. To reduce the possibility of the treadmill overheating, do not operate the treadmill continuously for longer than 1 hour.
17. Never leave the treadmill unattended while it is running. Always remove the key when the treadmill is not in use.
18. Do not attempt to raise, lower, or move the treadmill until it is properly assembled. (See ASSEMBLY on page 5, and HOW TO MOVE THE TREADMILL on page 10.) You must be able to safely lift 45 pounds (20 kg) in order to raise, lower, or move the treadmill.
19. Do not change the incline of the treadmill by placing objects under the treadmill.

20. When folding or moving the treadmill, make sure that the storage latch is fully closed.
21. Inspect and tighten all parts of the treadmill regularly.
22. Never drop or insert any object into any opening.
23. **DANGER:** Always unplug the power cord immediately after use, before cleaning the treadmill, and before performing the maintenance and adjustment procedures described in this manual. Never remove the motor hood unless instructed to do so by an authorized service representative. Servicing other than the procedures in this manual should be performed by an authorized service representative only.
24. This treadmill is intended for in-home use only. Do not use this treadmill in any commercial, rental, or institutional setting.

⚠ WARNING: Before beginning this or any exercise program, consult your physician. This is especially important for persons over the age of 35 or persons with pre-existing health problems. Read all instructions before using. ICON assumes no responsibility for personal injury or property damage sustained by or through the use of this product.

SAVE THESE INSTRUCTIONS

The decal shown below has been placed on your treadmill. If the decal is missing, or if it is not legible, please call our Customer Service Department, toll-free, to order a free replacement decal (see ORDERING REPLACEMENT PARTS on the back cover of this manual). Apply the decal in the location shown.

⚠ WARNING

- Never allow children to play on or around treadmill.
- Storage latch must be fully engaged before treadmill is moved or stored.

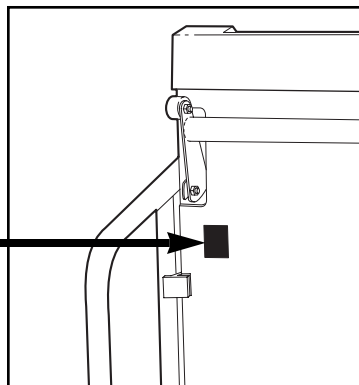

BEFORE YOU BEGIN

Thank you for selecting the PROFORM® 385EX treadmill. The 385EX treadmill combines advanced technology with innovative design to let you enjoy an excellent form of cardiovascular exercise in the convenience and privacy of your home. And when you're not exercising, the unique 385EX can be folded up, requiring less than half the floor space of other treadmills.

For your benefit, read this manual carefully before using the treadmill. If you have additional questions, please call our Customer Service Department toll-free

at 1-800-999-3756, Monday through Friday, 6 a.m. until 6 p.m. Mountain Time (excluding holidays). To help us assist you, please note the product model number and serial number before calling. The model number of the treadmill is PFTL38581. The serial number can be found on a decal attached to the treadmill (see the front cover of this manual for the location).

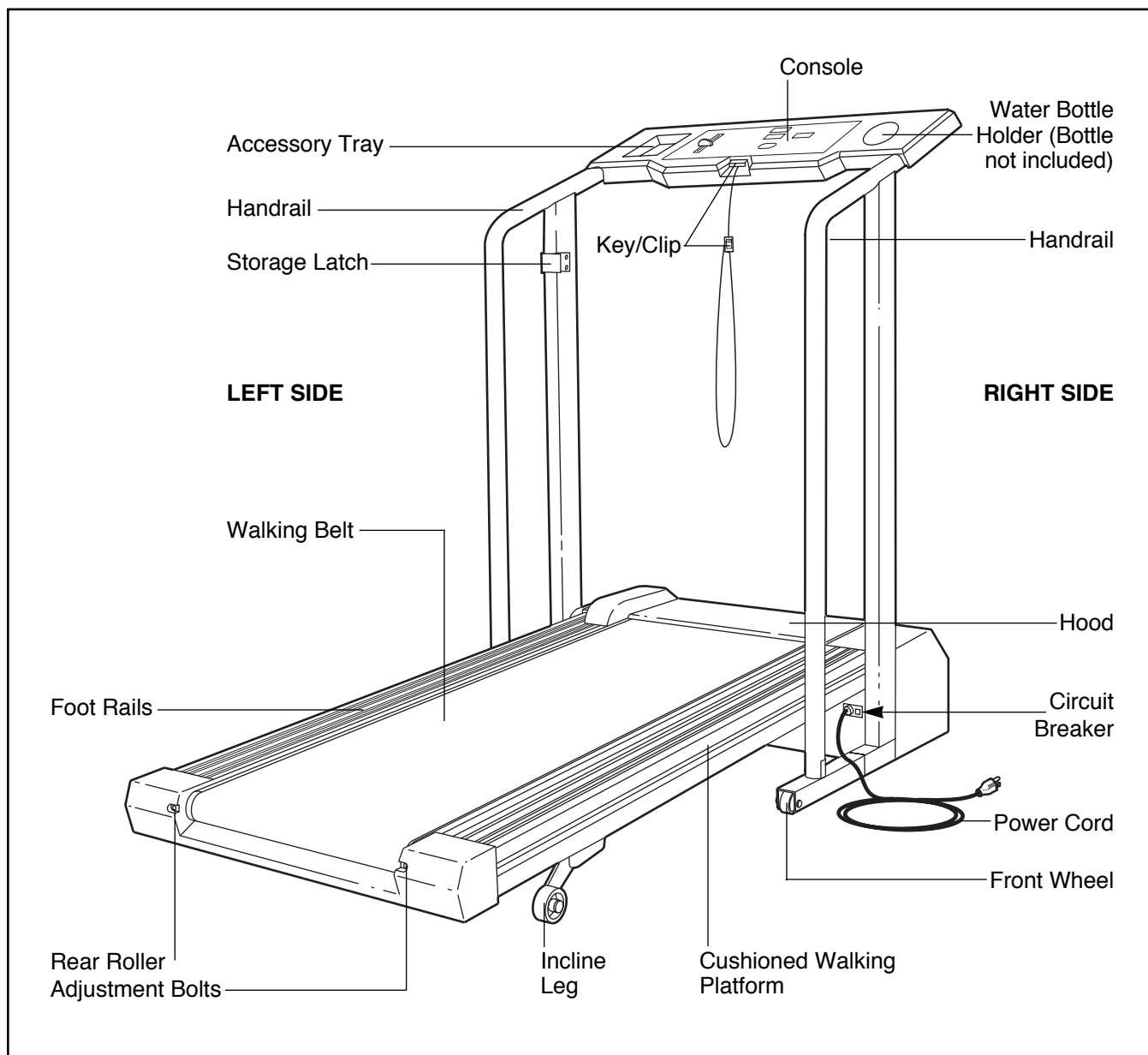

Before reading further, please review the drawing below and familiarize yourself with the labeled parts.



ASSEMBLY

Assembly requires two people. Set the treadmill in a cleared area and remove all packing materials. Do not dispose of the packing materials until assembly is completed. Note: The treadmill walking deck is coated with high-performance lubricant. During shipping, a small amount of lubricant may be transferred to the top of the walking belt or the shipping carton. This is a normal condition and does not affect treadmill performance. If there is lubricant on top of the walking belt, wipe off the lubricant with a soft cloth and a mild, non-abrasive cleaner.

During assembly, refer to the drawings at the right to identify the small parts used in assembly.

Assembly requires a phillips screwdriver , **an adjustable wrench** , **and scissors (not included), as well as the included allen wrench** .

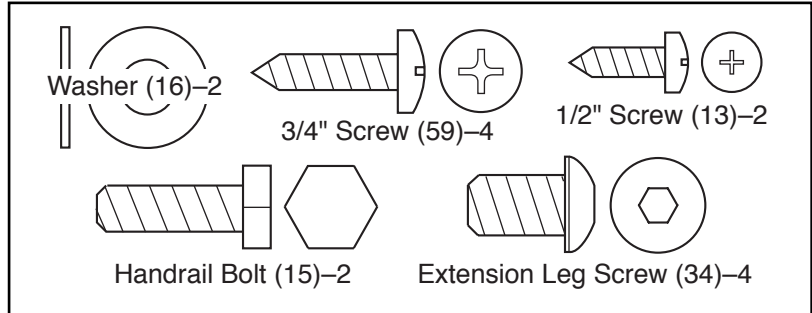

1. With the help of a second person, carefully raise the Uprights (14), the right Handrail (2), and the Console Base (6) until the treadmill is in the position shown. **Be careful not to pull on the Wire Harness (26).** Set the Right Handrail on the right Upright until step 3 is completed.

Refer to the inset drawing. Insert one of the Extension Legs (41) into the treadmill as shown. (Note: It may be helpful to tip the Uprights (14) in the direction shown by the arrow as you insert the Extension Leg.) Make sure that the Base Pad (36) is on the bottom of the Extension Leg. Attach the Extension Leg with an Extension Leg Screw (34). **Be sure to push on the head of the Extension Leg Screw while tightening it.**

Attach the other Extension Leg (41) in the same way.

2. Cut the plastic ties that hold the cage nuts in each Handrail (2).

Position one of the Handrails (2) on the left Upright (14). The lower end of the Left Handrail should be resting against the bracket on the Extension Leg (41) as shown. Thread a Handrail Bolt (15) with a Handrail Washer (16) into the left Upright and Handrail. **Do not tighten the Handrail Bolt yet.**

Make sure that the hole in the bracket on the Extension Leg (41) is aligned with the hole in the Handrail (2). Tighten an Extension Leg Screw (34) into the bracket and Handrail.

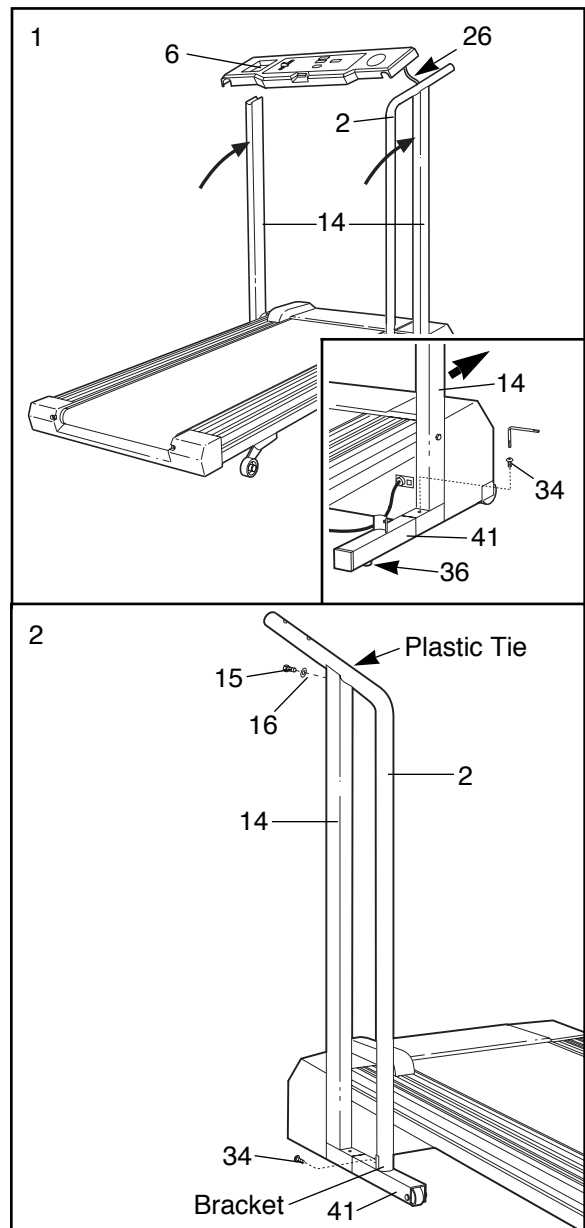

3. With the help of a second person, lift the right Handrail (2) off the right Upright (14). Hold the Console Base (6) and the Right Handrail in the position shown. Feed all of the excess Wire Harness (26) into the Right Handrail, through the indicated bracket, and down into the right Upright; bend the Wire Harness, if necessary.

Cut the indicated plastic tie off the right Handrail (2).

Make sure that the Wire Harness (26) is in the bracket and insert the bracket into the right Upright (14). **Make sure that the Wire Harness is not pinched.**

4. Thread a Handrail Bolt (15) with a Handrail Washer (16) into the right Upright (14) and the right Handrail (2). **Do not tighten the Handrail Bolt yet.**

Make sure that the hole in the bracket on the Extension Leg (41) is aligned with the hole in the Handrail (2). Tighten an Extension Leg Screw (34) into the bracket and Handrail.

5. Attach the Console Base (6) to the Handrails (2) with four 3/4" Screws (59).

Tighten all parts used in steps 2, 4, and 5.

6. Remove the backing from the Adhesive Clip (74). Press the Adhesive Clip onto the base of the Uprights (14) in the indicated location. Press the Allen Wrench (73) into the Adhesive Clip.

7. Attach the Storage Latch (12) to the left Upright (14) with two 1/2" Screws (13). Be careful not to overtighten the Screws.

8. **Make sure that all parts are tight before you use the treadmill.** (Note: The ratchet screws shown at the far right are factory set and **should not be adjusted.**) To protect the floor or carpet from damage, place a mat under the treadmill.

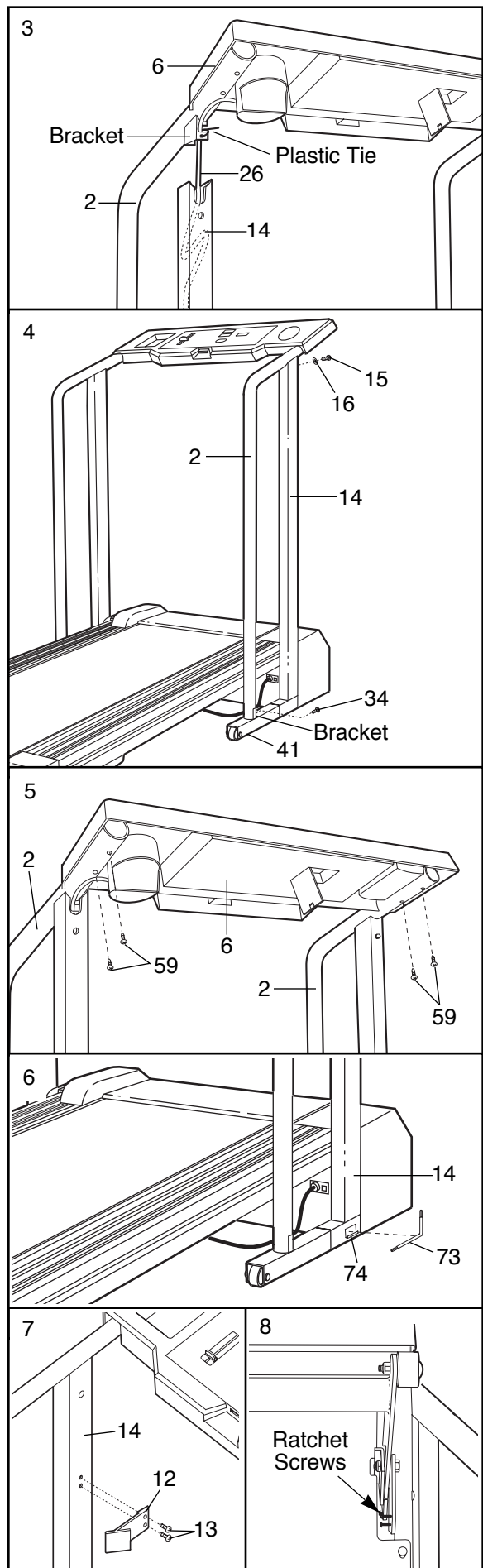

OPERATION AND ADJUSTMENT

THE PERFORMANT LUBE™ WALKING BELT

Your treadmill features a walking belt coated with PERFORMANT LUBE™, a high-performance lubricant. **IMPORTANT: Never apply silicone spray or other substances to the walking belt or the walking platform. They will deteriorate the walking belt and cause excessive wear.**

HOW TO PLUG IN THE POWER CORD

⚠ DANGER: Improper connection of the equipment-grounding conductor can result in an increased risk of electric shock. Check with a qualified electrician or serviceman if you are in doubt as to whether the product is properly grounded. Do not modify the plug provided with the product—if it will not fit the outlet, have a proper outlet installed by a qualified electrician.

Your treadmill, like any other type of sophisticated electronic equipment, can be seriously damaged by sudden voltage changes in your home's power. Voltage surges, spikes, and noise interference can result from weather conditions or from other appliances being turned on or off.

To decrease the possibility of your treadmill being damaged, always use a surge protector (not included) with your treadmill.

Surge protectors are sold at most hardware stores and department stores. Use only a UL-listed surge protector, rated at 15 amps, with a 14-gauge cord of five feet or less in length.

This product must be grounded. If it should malfunction or break down, grounding provides a path of least resistance for electric current to reduce the risk of

electric shock. This product is equipped with a cord having an equipment-grounding conductor and a grounding plug. **Plug the power cord into a surge protector, and plug the surge protector into an appropriate outlet that is properly installed and grounded in accordance with all local codes and ordinances.**

This product is for use on a nominal 120-volt circuit, and has a grounding plug that looks like the plug illustrated in drawing 1 below. A temporary adapter that looks like the adapter illustrated in drawing 2 may be used to connect the surge protector to a 2-pole receptacle as shown in drawing 2 if a properly grounded outlet is not available.

The temporary adapter should be used only until a properly grounded outlet (drawing 1) can be installed by a qualified electrician.

The green-colored rigid ear, lug, or the like extending from the adapter must be connected to a permanent ground such as a properly grounded outlet box cover. Whenever the adapter is used it must be held in place by a metal screw. **Some 2-pole receptacle outlet box covers are not grounded. Contact a qualified electrician to determine if the outlet box cover is grounded before using an adapter.**

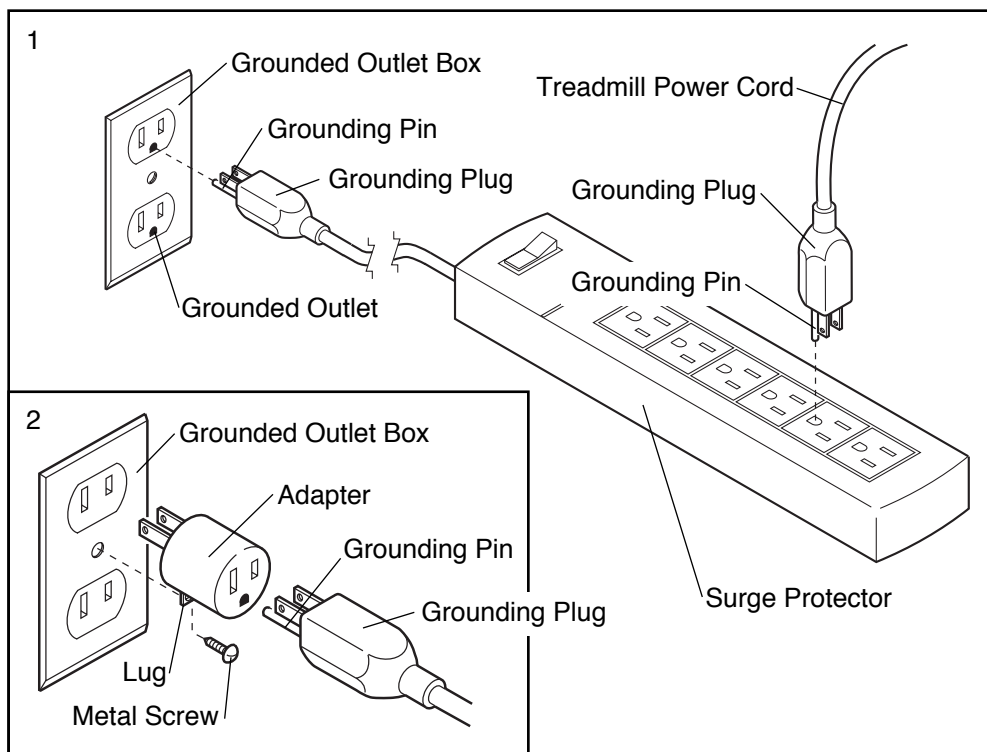
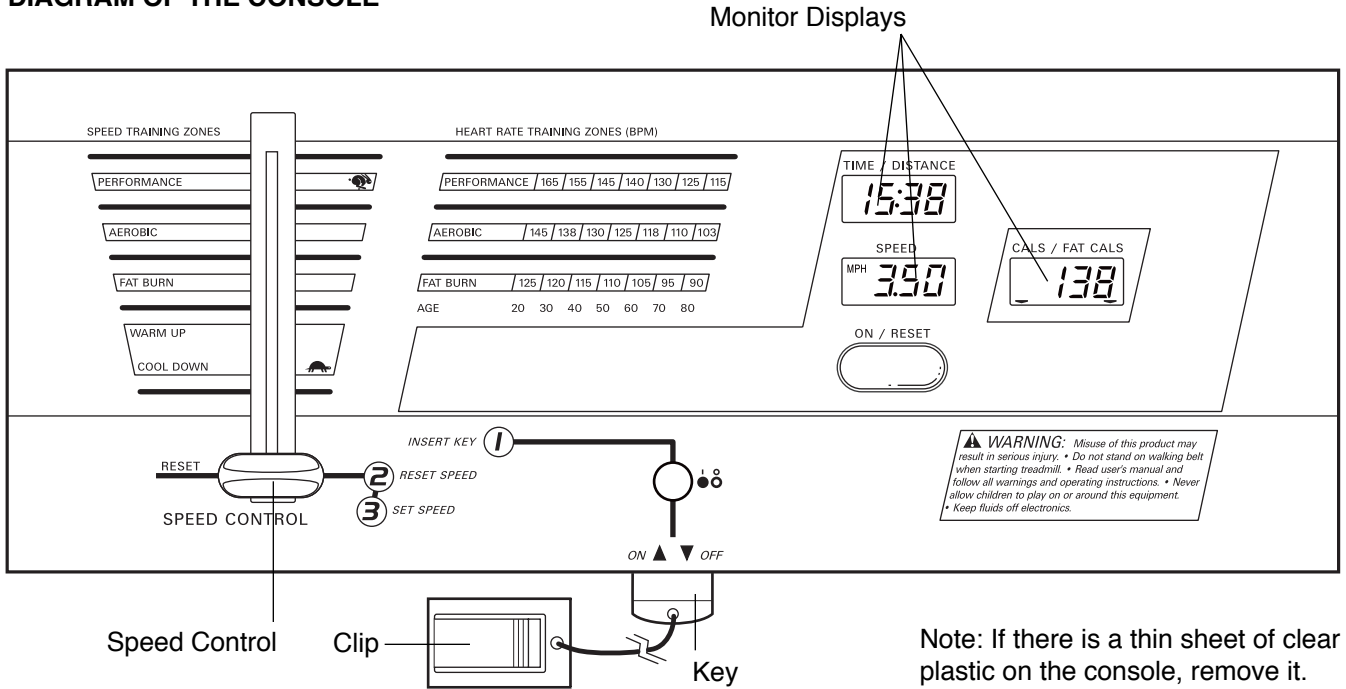

DIAGRAM OF THE CONSOLE



CAUTION: Before operating the console, read the following precautions.

- Do not stand on the walking belt when turning on the power.
- Always wear the clip (see the drawing above) while operating the treadmill. When the key is removed from the console, the walking belt will stop.

- Adjust the speed in small increments.
- The training zones marked beside the speed control are general guidelines only. See page 14 or more information.
- To reduce the possibility of electric shock, keep the console dry. Avoid spilling liquids on the console and use only a sealable water bottle.

BATTERY INSTALLATION

The console requires **three "AA" batteries** (not included). Alkaline batteries are recommended. To install batteries, open the battery cover as shown. Press the batteries into the battery compartment, with the negative ends of the batteries (marked “-”) touching the springs. Close the battery cover, push up on the battery cover tab, and then push the tab forward as shown. Be sure that the tab locks into place.

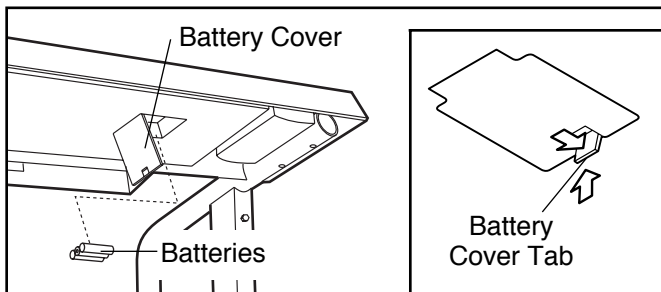

STEP BY STEP CONSOLE OPERATION

Step onto the foot rails of the treadmill. Find the clip attached to the key (see the drawing above), and slide the clip onto the waistband of your clothing. Follow the steps below and on page 9 to operate the console.

1 Insert the key fully into the power switch.

Note: Inserting the key will not turn on the displays. The displays will turn on when the ON/RESET button is pressed or when the walking belt is started. If you just installed batteries, the displays will already be on.

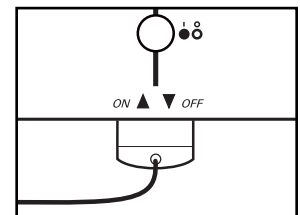

2 Reset the console and start the walking belt.

Slide the speed control to the RESET position. **Note: Each time the walking belt is stopped, the speed control must be moved to the RESET position before the walking belt can be restarted.**

Next, slowly slide the speed control until the walking belt begins to move at slow speed. Carefully step onto the walking belt and begin exercising. Change the speed of the walking belt as desired by moving the speed control.

To stop the walking belt, step onto the foot rails and slide the speed control to the RESET position.

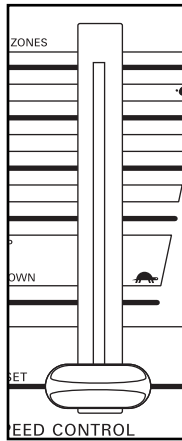

3 Follow your progress with the four displays.

TIME/DISTANCE display—This display shows the elapsed time and distance that you have walked or run, in miles.

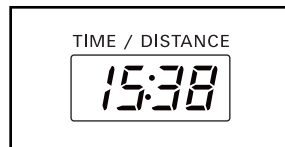

SPEED display—This display shows the speed of the walking belt, in miles per hour.

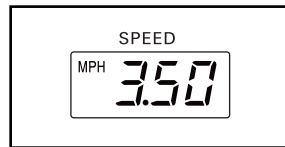

CALORIES/FAT CALORIES display—This display shows the approximate numbers of calories and fat calories you have burned. (See FAT BURNING on page 14.) Every seven seconds, the display will change from one number to the other, as indicated by the mode arrows.

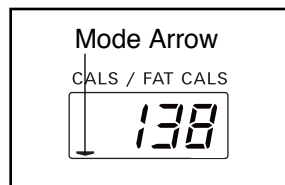

The displays can be reset, if desired, by pressing the ON/RESET button.

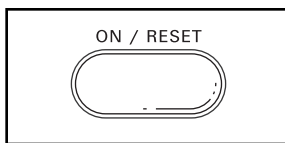

4 Turn off the power.

To turn off the power, simply wait for about four minutes. If the walking belt is stationary and the console buttons are not pressed for four minutes, the power will turn off automatically.

HOW TO CHANGE THE INCLINE OF THE TREADMILL

The incline of the treadmill can be changed by raising or lowering the back end. **Before changing the incline, remove the key and unplug the power cord.**

Hold the rear roller endcap with both hands. When the back end of the treadmill is in the lowest position, the incline is about 10%.

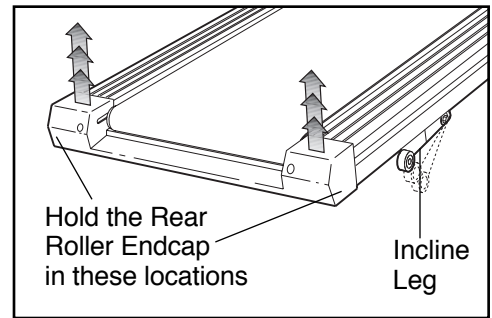

Raise the back end until it clicks into position. (Note: It may be necessary to shake the treadmill lightly so that it clicks into position.) The incline will then be about 5%. Raise the back end again until it clicks into position. The incline will then be about 3%. To lower the back end, raise it past the highest position and then lower it. **CAUTION: Before exercising, push on the back of the treadmill to make sure that the incline legs are locked in position. Do not place objects under the treadmill to change the incline; change the incline only as described above.**

HOW TO FOLD AND MOVE THE TREADMILL

HOW TO FOLD THE TREADMILL FOR STORAGE

Unplug the power cord. **Caution: You must be able to safely lift 45 pounds (20 kg) in order to raise, lower, or move the treadmill.**

1. Hold the treadmill with your hands in the locations shown at the right. **Caution: To decrease the possibility of injury, bend your legs and keep your back straight. As you raise the treadmill, make sure to lift with your legs rather than your back.** Raise the treadmill about halfway to the vertical position.

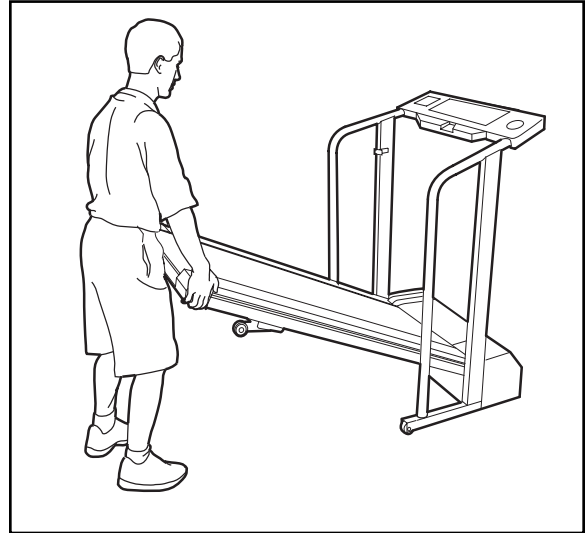

2. Move your right hand to the position shown and hold the treadmill firmly. Raise the treadmill until the storage latch closes over the catch. **Make sure that the storage latch is fully engaged over the catch.**

To protect the floor or carpet from damage, place a mat under the treadmill. Keep the treadmill out of direct sunlight. Do not leave the treadmill in the storage position in temperatures above 85° Fahrenheit.

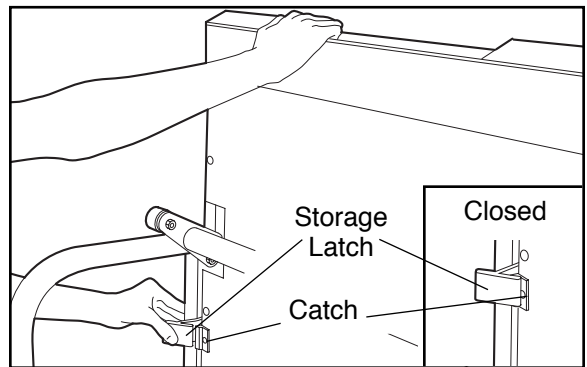

HOW TO MOVE THE TREADMILL

Before moving the treadmill, convert the treadmill to the storage position as described above. **Make sure that the storage latch is closed fully over the catch.**

1. Hold the handrails and place one foot on the base as shown.
2. Tilt the treadmill back until it rolls freely on the front wheels. Carefully move the treadmill to the desired location. **Never move the treadmill without tipping it back. To reduce the risk of injury, use extreme caution while moving the treadmill. Do not attempt to move the treadmill over an uneven surface.**
3. Place one foot on the base, and carefully lower the treadmill until it is resting in the storage position.

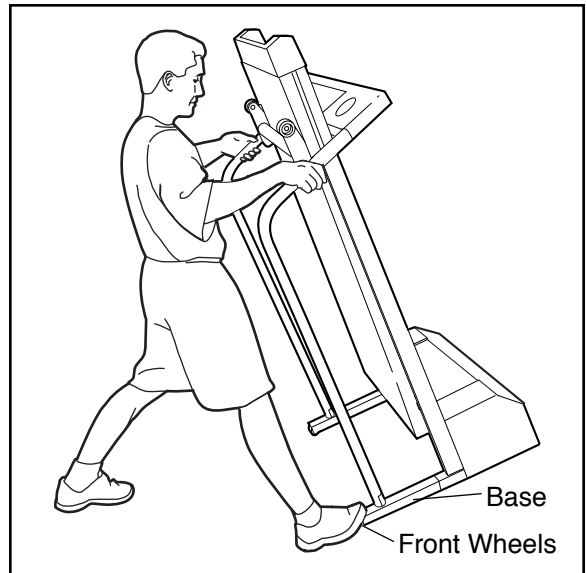

HOW TO LOWER THE TREADMILL FOR USE

1. Hold the upper end of the treadmill with your right hand as shown. Using your left thumb, press the storage latch and hold it. Pivot the treadmill until the frame and foot rail are past the storage latch.

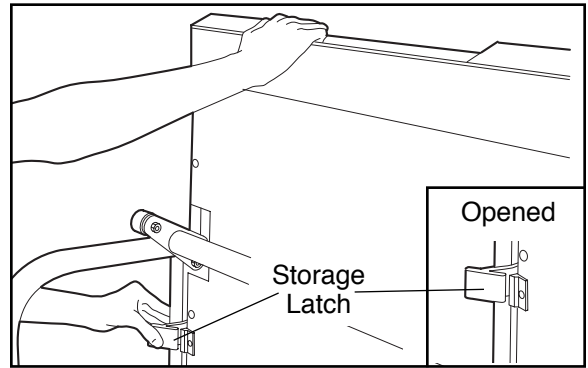

2. Hold the treadmill firmly with both hands, and lower the treadmill to the floor. **Caution: To decrease the possibility of injury, bend your legs and keep your back straight.**

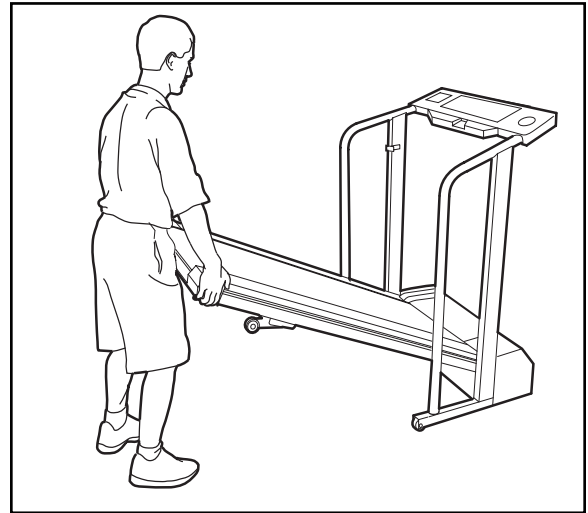

MAINTENANCE AND TROUBLE-SHOOTING

Most treadmill problems can be solved by following the steps below. Find the symptom that applies, and follow the steps listed. If further assistance is needed, please call our Customer Service Department toll-free at 1-800-999-3756, Monday through Friday, 6 a.m. until 6 p.m. Mountain Time (excluding holidays).

PROBLEM: The power does not turn on

SOLUTION: a. Make sure that the power cord is plugged into a surge protector, and that the surge protector is plugged into a properly grounded outlet. (See HOW TO PLUG IN THE POWER CORD on page 7.) Use only a UL-listed surge protector, rated at 15 amps, with a 14-gauge cord of five feet or less in length.

b. After the power cord has been plugged in, make sure that the key is fully inserted into the console. (See step 1 on page 8.)

c. Check the circuit breaker located on the treadmill near the power cord. If the switch protrudes as shown, the circuit breaker has tripped. To reset the circuit breaker, wait for five minutes and then press the switch back in.

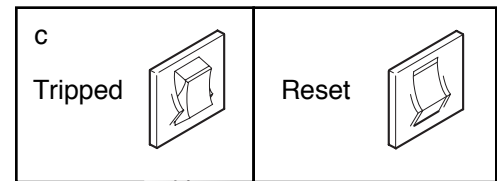

PROBLEM: The power turns off during use

SOLUTION: a. Check the circuit breaker located on the treadmill frame near the power cord (see 1. c. above). If the circuit breaker has tripped, wait for five minutes and then press the switch back in.

b. Make sure that the power cord is plugged in.

c. Remove the key from the console. Reinsert the key fully into the console. (See step 1 on page 8.)

d. If the treadmill still will not run, please call our Customer Service Department, toll-free.

PROBLEM: The displays of the console do not function properly

SOLUTION: a. Check the batteries in the console. See BATTERY INSTALLATION on page 8. Most problems are the result of drained batteries.

b. Remove the key from the console and **UNPLUG THE POWER CORD**. Next, remove the screws from the hood and carefully remove the hood. Locate the Reed Switch (86) and the Magnet (87) on the left side of the Pulley (85). Turn the Pulley until the Magnet is aligned with the Reed Switch. **Make sure that the gap between the Magnet and the Reed Switch is about 1/8"**. If necessary, loosen the Screw (67) and move the Reed Switch slightly. Retighten the Screw. Re-attach the hood, and run the treadmill for a few minutes to check for a correct speed reading.

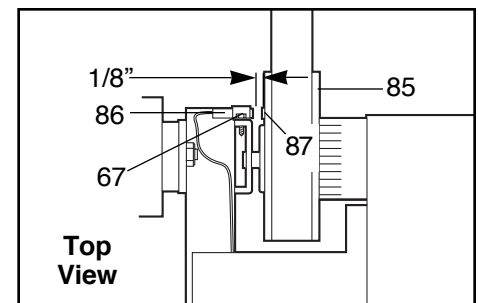

PROBLEM: The walking belt slows when walked on

SOLUTION: a. Use only a UL-listed surge protector, rated at 15 amps, with a 14-gauge cord of five feet or less in length.

b. If the walking belt is overtightened, treadmill performance may decrease and the walking belt may be permanently damaged. Remove the key and **UNPLUG THE POWER CORD**. Using the allen wrench, turn both rear roller adjustment bolts counterclockwise, 1/4 of a turn. When the walking belt is properly tightened, you should be able to lift each side of the walking belt 2 to 3 inches off the walking platform. Be careful to keep the walking belt centered. Plug in the power cord, insert the key and run the treadmill for a few minutes. Repeat until the walking belt is properly tightened.

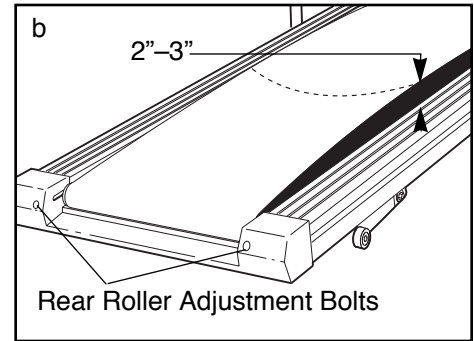

c. If the walking belt still slows when walked on, please call our Customer Service Department, toll-free.

PROBLEM: The walking belt is off-center when walked on

SOLUTION: a. If the walking belt has shifted to the left, first remove the key and **UNPLUG THE POWER CORD**. Using the allen wrench, turn the left rear roller adjustment bolt clockwise, and the right bolt counterclockwise, 1/4 of a turn each. Be careful not to overtighten the walking belt. Plug in the power cord, insert the key and run the treadmill for a few minutes. Repeat until the walking belt is centered.

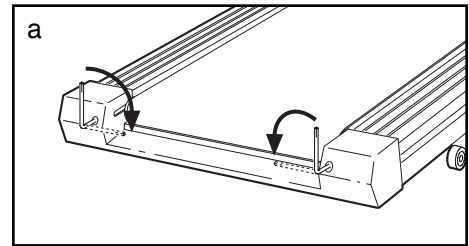

b. If the walking belt has shifted to the right, first remove the key and **UNPLUG THE POWER CORD**. Using the allen wrench, turn the left rear roller adjustment bolt counterclockwise, and the right bolt clockwise, 1/4 of a turn each. Be careful not to overtighten the walking belt. Plug in the power cord, insert the key and run the treadmill for a few minutes. Repeat until the walking belt is centered.

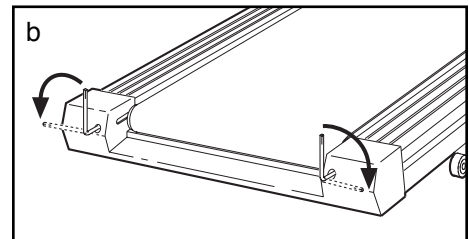

PROBLEM: The walking belt slips when walked on

SOLUTION: a. If the walking belt slips when walked on, first remove the key and **UNPLUG THE POWER CORD**. Using the allen wrench, turn both rear roller adjustment bolts clockwise, 1/4 of a turn. When the walking belt is correctly tightened, you should be able to lift each side of the walking belt 2 to 3 inches off the walking platform. Be careful to keep the walking belt centered. Plug in the power cord, insert the key and carefully walk on the treadmill for a few minutes. Repeat until the walking belt is properly tightened.

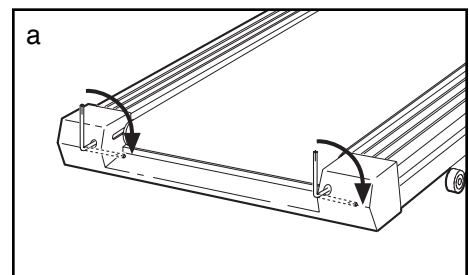

CONDITIONING GUIDELINES

⚠ WARNING: Before beginning this or any exercise program, consult your physician. This is especially important for individuals over the age of 35 or individuals with pre-existing health problems.

The following guidelines will help you to plan your exercise program. Remember—these are general guidelines only. For more detailed exercise information, obtain a reputable book or consult your physician.

EXERCISE INTENSITY

Whether your goal is to burn fat or to strengthen your cardiovascular system, the key to achieving the desired results is to exercise with the proper intensity. The proper intensity level can be found by using your heart rate as a guide. The chart below shows recommended heart rates for fat burning and aerobic exercise. (This chart is also found on the console.)

| HEART RATE TRAINING ZONES (BPM) | | | | | | | | |
|---------------------------------|---|----|----|----|----|----|----|--|
| | PERFORMANCE / 165 / 155 / 145 / 140 / 130 / 125 / 115 | | | | | | | |
| | AEROBIC / 145 / 138 / 130 / 125 / 118 / 110 / 103 | | | | | | | |
| | FAT BURN / 125 / 120 / 115 / 110 / 105 / 95 / 90 | | | | | | | |
| AGE | 20 | 30 | 40 | 50 | 60 | 70 | 80 | |

To find the proper heart rate for you, first find your age at the bottom of the chart (ages are rounded off to the nearest ten years). Next, find the three numbers above your age. The three numbers are your “training zone.” The lower two numbers are recommended heart rates for fat burning; the higher number is the recommended heart rate for aerobic exercise.

Fat Burning

To burn fat effectively, you must exercise at a relatively low intensity level for a sustained period of time. During the first few minutes of exercise, your body uses easily accessible carbohydrate calories for energy. Only after the first few minutes does your body begin to use stored fat calories for energy. If your goal is to burn fat, adjust the speed and incline of the treadmill until your heart rate is near one of the lower two numbers in your

training zone. It may also be helpful to set the speed control on the console to FAT BURN to help you maintain the proper intensity level. (See page 9.)

Aerobic Exercise

If your goal is to strengthen your cardiovascular system, your exercise must be “aerobic.” Aerobic exercise is activity that requires large amounts of oxygen for prolonged periods of time. This increases the demand on the heart to pump blood to the muscles, and on the lungs to oxygenate the blood. For aerobic exercise, adjust the speed and incline of the treadmill until your heart rate is near the highest number in your training zone. It may also be helpful to set the speed control on the console to AEROBIC to help you maintain the proper intensity level. (See page 9.)

High Performance Athletic Conditioning

If your goal is high performance athletic conditioning, set the speed control on the console to PERFORMANCE to help you maintain the proper intensity level. (See page 9.) Note: During the first few weeks of your exercise program, keep your heart rate near the low end of your training zone.

HOW TO MEASURE YOUR HEART RATE

To measure your heart rate, stop exercising and place two fingers on your wrist as shown. Take a six-second heartbeat count, and multiply the result by ten to find your heart

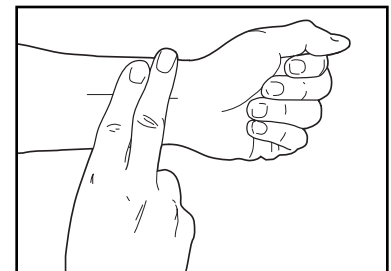

rate. (A six-second count is used because your heart rate drops quickly when you stop exercising.) If your heart rate is too high or too low, adjust the speed or incline of the treadmill accordingly.

WORKOUT GUIDELINES

A well-rounded workout includes the following three important parts:

A Warm-up

Start each workout with 5 to 10 minutes of stretching and light exercise (see SUGGESTED STRETCHES on page 15). A proper warm-up increases your body temperature, heart rate, and circulation in preparation for exercise.

Exercise Frequency

To maintain or improve your condition, complete three workouts each week, with at least one day of rest be-

tween workouts. After a few months, you may complete up to five workouts each week if desired. The key to success is to make exercise a regular and enjoyable part of your everyday life.

SUGGESTED STRETCHES

The correct form for several basic stretches is shown in the drawings at the right. Move slowly as you stretch—never bounce.

1. Toe Touch Stretch

Stand with your knees bent slightly and slowly bend forward from your hips. Allow your back and shoulders to relax as you reach down toward your toes as far as possible. Hold for 15 counts, then relax. Repeat 3 times. Stretches: Hamstrings, back of knees and back.

2. Hamstring Stretch

Sit with one leg extended. Bring the sole of the opposite foot toward you and rest it against the inner thigh of your extended leg. Reach toward your toes as far as possible. Hold for 15 counts, then relax. Repeat 3 times for both legs. Stretches: Hamstrings, lower back and groin.

3. Calf/Achilles Stretch

With one leg in front of the other, reach forward and place your hands against a wall. Keep your back leg straight and your back foot flat on the floor. Bend your front leg, lean forward and move your hips toward the wall. Hold for 15 counts, then relax. Repeat 3 times for both legs. To cause further stretching of the achilles tendons, bend your back leg as well. Stretches: Calves, achilles tendons and ankles.

4. Quadriceps Stretch

With one hand against a wall for balance, reach back and grasp one foot with your other hand. Bring your heel as close to your buttocks as possible. Hold for 15 counts, then relax. Repeat 3 times for both legs. Stretches: Quadriceps and hip muscles.

5. Inner Thigh Stretch

Sit with the soles of your feet together and your knees outward. Pull your feet toward your groin area as far as possible. Hold for 15 counts, then relax. Repeat 3 times. Stretches: Quadriceps and hip muscles.

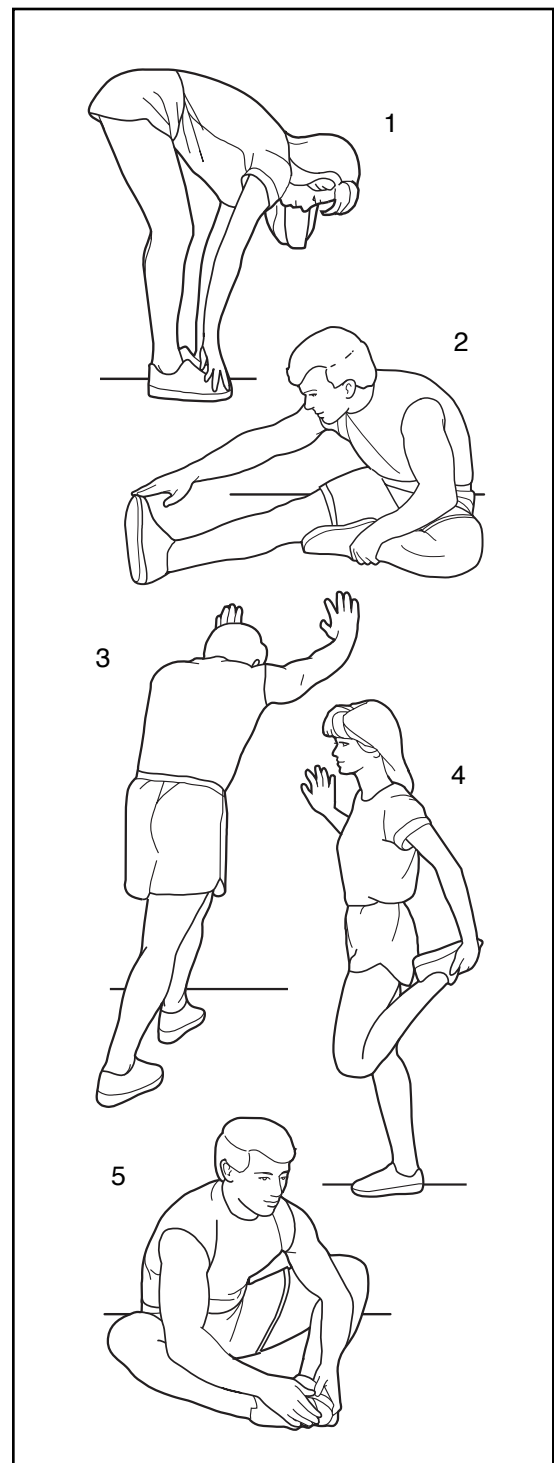

PART LIST—Model No. PFTL38581

R0799A

| Key No. | Qty. | Description | Key No. | Qty. | Description |
|---------|------|---------------------------------|---------|------|-----------------------------------|
| 1 | 1 | Key/Clip | 48 | 1 | Choke |
| 2 | 2 | Handrail | 49 | 1 | Motor Locknut |
| 3 | 2 | Cage Nut | 50 | 2 | Belt Guide |
| 4 | 1 | Left Upright Spacer | 51 | 1 | Belly Pan |
| 5 | 2 | Rear Isolator Screw | 52 | 1 | Releasable Tie |
| 6 | 1 | Console Base | 53 | 1 | Cable Tie Clamp |
| 7 | 1 | Speed Control Knob | 54 | 1 | Motor Belly Pan |
| 8 | 1 | Speed Potentiometer | 55 | 1 | Left Footrail |
| 9 | 1 | Battery Cover | 56 | 4 | 8" Cable Tie |
| 10 | 8 | Isolator Screw | 57 | 1 | Ratchet Spring |
| 11* | 1 | Console Assembly | 58 | 1 | Ratchet |
| 12 | 1 | Storage Latch | 59 | 11 | 3/4" Screw |
| 13 | 2 | 1/2" Screw | 60 | 1 | Ratchet Spring Screw |
| 14 | 1 | Upright/Base | 61 | 2 | Ratchet Screw |
| 15 | 2 | Handrail Bolt | 62 | 1 | Incline Leg Plate |
| 16 | 7 | Washer | 63 | 2 | Roller Guard |
| 17 | 1 | Motor Belt | 64 | 2 | Incline Wheel Bolt |
| 18 | 1 | Motor Swivel Nut | 65 | 2 | Incline Wheel |
| 19* | 1 | Motor/Pulley/Flywheel/Fan | 66 | 4 | Wheel Nut |
| 20 | 1 | Pulley/Flywheel/Fan | 67 | 9 | Belly Pan Screw/Reed Switch Screw |
| 21 | 1 | Motor | 68 | 1 | Ground Wire |
| 22 | 3 | Motor Tension Bolt/Incline Bolt | 69 | 1 | Incline Leg |
| 23 | 1 | Motor Tension Washer | 70 | 1 | Frame |
| 24 | 1 | Motor Tension Star Washer | 71 | 2 | Rear Roller Adj. Bolt |
| 25 | 1 | Motor Swivel Bolt | 72 | 1 | Rear Roller Endcap |
| 26 | 1 | Wire Harness | 73 | 1 | Allen Wrench |
| 27 | 2 | Ground Wire Screw | 74 | 1 | Adhesive Clip |
| 28 | 1 | Hood | 75 | 1 | Right Foot Rail |
| 29 | 1 | Hood Shield | 76 | 1 | Rear Roller |
| 30 | 14 | Screw/Handrail Screw | 77 | 4 | Platform Screw |
| 31 | 1 | Latch Decal | 78 | 1 | Latch Catch |
| 32 | 2 | Frame Pivot Washer | 79 | 1 | Walking Platform |
| 33 | 2 | Frame Pivot Bolt | 80 | 1 | Walking Belt |
| 34 | 2 | Extension Leg Screw | 81 | 1 | Front Roller Adjustment Bolt |
| 35 | 8 | Electronics Screw | 82 | 1 | Incline Leg Spacer (long) |
| 36 | 4 | Base Pad | 83 | 1 | Ratchet Pivot Bolt |
| 37 | 2 | Wheel Bolt | 84 | 1 | Sensor Clip |
| 38 | 2 | Wheel | 85 | 1 | Front Roller/Pulley |
| 39 | 7 | Wheel Nut/Base Pivot Nut | 86 | 1 | Reed Switch |
| 40 | 1 | Controller | 87 | 1 | Magnet |
| 41 | 2 | Extension Leg | 88 | 2 | Incline Leg Spacer (short) |
| 42 | 1 | Circuit Breaker | # | 1 | 8" White Wire, Male/Female |
| 43 | 1 | Power Cord Grommet | # | 1 | User's Manual |
| 44 | 1 | Power Cord | | | |
| 45 | 1 | Right Upright Spacer | | | |
| 46 | 4 | Isolator | | | |
| 47 | 12 | Belly Pan Fastener | | | |

* Includes all parts shown in the box

These parts are not illustrated

EXPLODED DRAWING — Model No. PFTL38581

R0799A

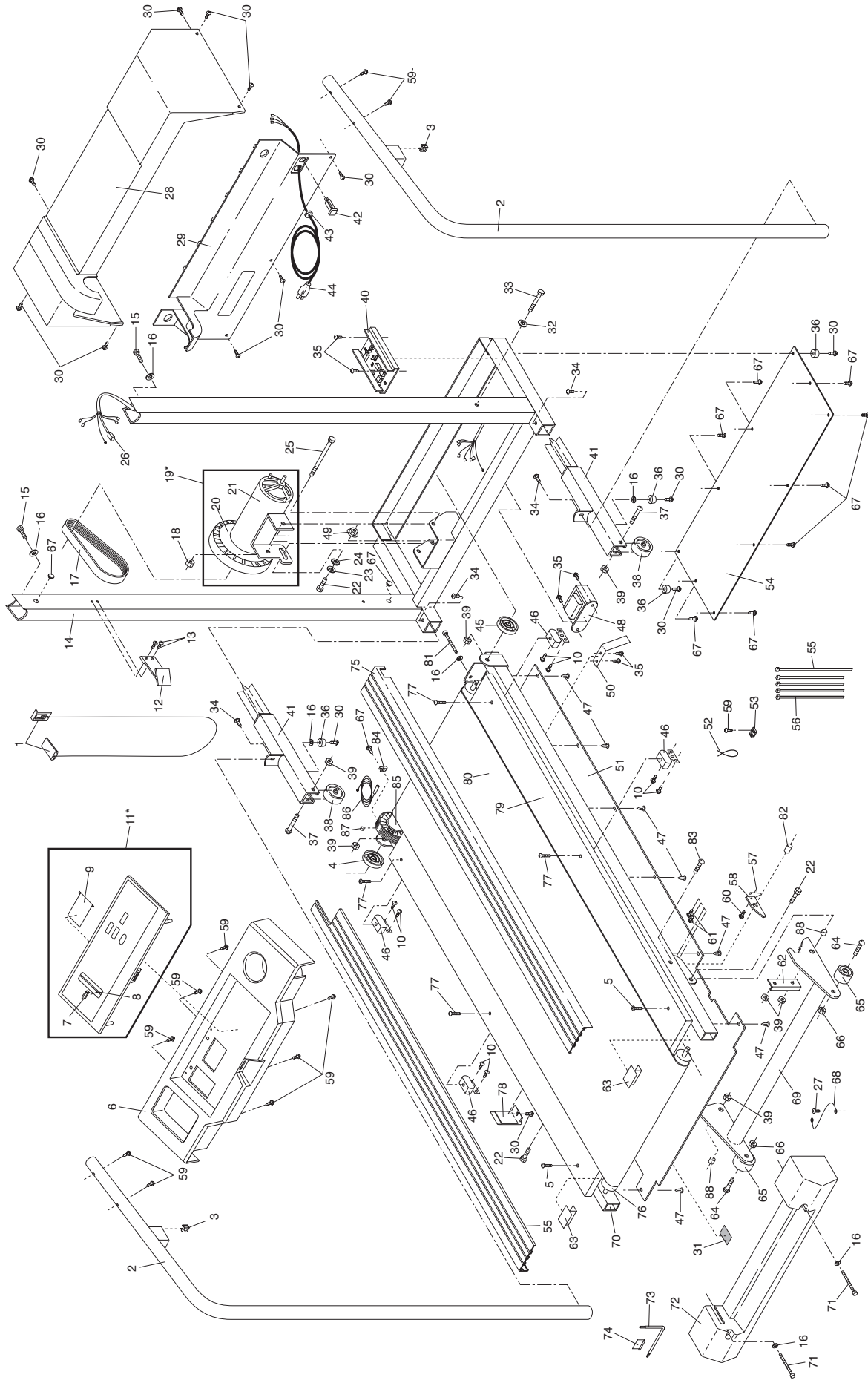

ORDERING REPLACEMENT PARTS

To order replacement parts, call our Customer Service Department toll-free at 1-800-999-3756, Monday through Friday, 6 a.m. until 6 p.m. Mountain Time (excluding holidays). When ordering parts, please be prepared to give the following information:

- The MODEL NUMBER OF THE PRODUCT (PFTL38581).
- The NAME OF THE PRODUCT (PROFORM® 385EX treadmill).
- The SERIAL NUMBER OF THE PRODUCT (see the front cover of this manual).
- The KEY NUMBER AND DESCRIPTION OF THE PART(S) (see the EXPLODED DRAWING and PART LIST attached to the center of this manual).

If possible, place the treadmill near your telephone for easy reference when calling.

LIMITED WARRANTY

ICON Health & Fitness, Inc. (ICON), warrants this product to be free from defects in workmanship and material, under normal use and service conditions, for a period of ninety (90) days from the date of purchase. This warranty extends only to the original purchaser. ICON's obligation under this warranty is limited to replacing or repairing, at ICON's option, the product at one of its authorized service centers. All products for which warranty claim is made must be received by ICON at one of its authorized service centers with all freight and other transportation charges prepaid, accompanied by sufficient proof of purchase. All returns must be pre-authorized by ICON. This warranty does not extend to any product or damage to a product caused by or attributable to freight damage, abuse, misuse, improper or abnormal usage or repairs not provided by an ICON authorized service center, to products used for commercial or rental purposes, or to products used as store display models. No other warranty beyond that specifically set forth above is authorized by ICON.

ICON is not responsible or liable for indirect, special or consequential damages arising out of or in connection with the use or performance of the product or damages with respect to any economic loss, loss of property, loss of revenues or profits, loss of enjoyment or use, costs of removal, installation or other consequential damages of whatsoever nature. Some states do not allow the exclusion or limitation of incidental or consequential damages. Accordingly, the above limitation may not apply to you.

The warranty extended hereunder is in lieu of any and all other warranties and any implied warranties of merchantability or fitness for a particular purpose is limited in its scope and duration to the terms set forth herein. Some states do not allow limitations on how long an implied warranty lasts. Accordingly, the above limitation may not apply to you.

This warranty gives you specific legal rights. You may also have other rights which vary from state to state.

ICON HEALTH & FITNESS, INC., 1500 S. 1000 W., LOGAN, UT 84321-9813