

TO RECEIVE MAXIMUM SERVICE & SUPPORT, COMPLETE AND RETURN THIS WARRANTY CARD TODAY!

WHAT IS COVERED:

This **Life Fitness** consumer product ("Product") is warranted to be free of all defects in material and workmanship.

WHO IS COVERED:

The original purchaser or any person receiving the Product as a gift from the original purchaser.

HOW LONG IS IT COVERED:

Residential: All electrical and mechanical components are covered, after the date of purchase, as listed on the chart. Labor is not covered, except as noted.

Non-Residential: Warranty void (this product is intended for residential use only).

WHO PAYS TRANSPORTATION & INSURANCE FOR SERVICE:

If the Product or any warranted part must be returned to a service facility for repairs, **We, Life Fitness**, will pay all transportation and insurance charges for the first year (within the United States, only). **You** are responsible for transportation and insurance charges during the second and third years (if applicable).

WHAT WE WILL DO TO CORRECT COVERED DEFECTS:

We will ship to you any new or rebuilt replacement part or component, or, at our option, replace the Product. Such replacement parts are warranted for the remaining portion of the original warranty period.

WHAT IS NOT COVERED:

Any failures or damage caused by unauthorized service, misuse, accident, negligence, improper assembly or installation, debris resulting from any construction activities in the Product's environment, rust or corrosion as a result of the Product's location, alterations or modifications without our written authorization or by failure on your part to use, operate and maintain the Product as set out in your Operation Manual ("*Manual*"). **All terms of this warranty are void if this product is moved beyond the continental borders of the United States of America (excluding Alaska, Hawaii and Canada) and are then subject to the terms provided by that country's local authorized Life Fitness Representative.**

WHAT YOU MUST DO:

Retain proof of purchase (*our receipt of the attached registration card assures registration of purchase information but is not required*); **use, operate and maintain** the Product as specified in the Manual; **notify** Customer Support Services of any defect within 10 days after discovery of the defect; if instructed, **return** any defective part for replacement or, if necessary, the entire Product for repair.

OPERATION MANUAL:

It is **VERY IMPORTANT THAT YOU READ THE MANUAL** before operating the Product. Remember to perform the periodic maintenance requirements specified in the Manual to assure proper operation and your continued satisfaction.

WARRANTY REGISTRATION:

Attached is a registration card. **COMPLETE and MAIL this card IMMEDIATELY.** Our receipt assures that your name, address and date of purchase are on file as a registered owner of the Product. Failure to return the card will not affect your rights under this warranty. Being a registered owner assures coverage in the event you lose your proof of purchase. In any event, always retain proof of purchase, such as your bill of sale.

HOW TO GET PARTS & SERVICE:

Simply call Customer Support Services at **(800) 351-3737** or **(847) 451-0036**, Monday through Friday from 8:00 a.m. to 6:00 p.m. Central Standard Time, and tell them your name, address and the serial number of your Product. They will tell you how to get a replacement part, or, if necessary, arrange for service where your Product is located or advise you on how and where to ship the Product for service.

Before shipping:

- ① **obtain** a Return Authorization Number (**RA#**) from Customer Support Services
- ② **securely pack** your Product (*use the original shipping carton, if possible*)
- ③ **write** the **RA#** on the outside of the carton
- ④ **insure** the Product, and
- ⑤ **include** a letter explaining the defect or problem and a copy of your proof of purchase if you believe the service is covered by warranty

EXCLUSIVE WARRANTY:

THIS LIMITED WARRANTY IS IN LIEU OF ALL OTHER WARRANTIES OF ANY KIND EITHER EXPRESSED OR IMPLIED, INCLUDING BUT NOT LIMITED TO THE IMPLIED WARRANTIES OF MERCHANTABILITY AND FITNESS FOR A PARTICULAR PURPOSE, AND ALL OTHER OBLIGATIONS OR LIABILITIES ON OUR PART. We neither assume nor authorize any person to assure for us any other obligation or liability concerning the sale of this Product. Under no circumstances shall we be liable under this warranty, or otherwise, of any damage to any person or property, including any lost profits or lost savings, for any special, indirect, secondary, incidental or consequential damages of any nature arising out of the use of or inability to use this Product. Some states do not allow the exclusion or limitation of implied warranties or of liability for incidental or consequential damages, so the above limitations or exclusions may not apply to you.

CHANGES IN WARRANTY NOT AUTHORIZED:

No one is authorized to change, modify or extend the terms of this limited warranty.

EFFECT OF STATE LAWS:

This warranty gives you specific legal rights and you may have other rights which vary from state to state.

OUR PLEDGE TO YOU:

Our Products are designed and manufactured to the highest standards. We want you completely satisfied with our Products and will do everything possible under the terms of this warranty to keep you secure in knowing you have bought the best!



NO POSTAGE
NECESSARY IF
MAILED IN THE
UNITED STATES

BUSINESS REPLY MAIL
FIRST CLASS MAIL PERMIT NO. 50 FRANKLIN PARK, IL

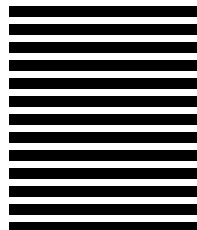

10601 West Belmont Avenue
Franklin Park, IL 60131-9832



... with Our Personal Guarantee



MODEL	LIFETIME	3 YEARS	2 YEARS	1 YEAR
Bikes 6000 Series 5000 Series 4000 Series 3000 Series	N/A	Electrical & Mechanical Parts. Electrical & Mechanical Parts. Electrical & Mechanical Parts.	N/A	Transportation & Insurance Charges. Transportation & Insurance Charges. Transportation & Insurance Charges. Transportation & Insurance Charges, Electrical & Mechanical Parts.
Treadmills 5000 Series 4000 Series 3000 Series	Lifespring™ shock absorbers Lifespring™ shock absorbers Lifespring™ shock absorbers	Motor, Striding Belt, Deck, Electrical and Mechanical Parts. Motor, Striding Belt, Deck, Electrical and Mechanical Parts.	N/A	Transportation, Insurance Charges, & Labor. Transportation, Insurance Charges, & Labor. Motor, Striding Belt, Deck, Electrical and Mechanical Parts, Transportation & Insurance Charges, Labor.
Stairclimbers 5000 Series	N/A	N/A	Electrical & Mechanical Parts.	N/A
Cross-Trainers 5000 Series	N/A	Electrical & Mechanical Parts.	N/A	N/A

Note:

- The Telemetry Heart Rate Kit is warranted for 1 Year on Electrical Parts and 90 Days on the Elastic Strap.
- Shrouds, Product Decals and Console Overlays are warranted for 6 Months.

M051-00K20-D002 (9/99)

WARRANTY REGISTRATION

Please Fill In and Mail This Card Within 10 Days.

YOUR NAME _____

ADDRESS _____

CITY _____ STATE _____ ZIP CODE _____

() _____
PHONE NUMBER _____

BIKE

TREADMILL

STAIRCLIMBER

CROSS-TRAINER

MODEL NUMBER _____

SERIAL NUMBER _____

DATE PURCHASED _____

To help us serve you better, please answer the following questions:

Who will be the primary user of the Product? (circle one)

1. adult male 2. adult female 3. child/children

What is the age of the primary user? (circle one)

1. under 18 2. 18-24 3. 25-34 4. 35-44
5. 45-54 6. 55-64 7. 65 or over

What is your total annual household income range? (circle one)

1. less than \$25,000 2. \$25,000-\$34,999 3. \$35,000-\$44,999
4. \$45,000-\$54,999 5. \$55,000 -74,999 6. \$75,000 or more

What best describes your type of employment? (circle one)

1. skilled tradesman 2. general labor 3. executive 4. professional
5. self-employed 6. retired 7. other

How were you informed about Life Fitness products? (circle one)

1. health club 2. newspaper ad 3. magazine ad 4. television ad
5. doctor 6. personal trainer 7. editorial 8. other

Have you previously purchased a Life Fitness product? (circle one)

1. Yes 2. No

If yes, which product? (circle all that apply)

1. Lifecycle bike 2. Treadmill 3. Stairclimber 4. Other

Were you happy with your purchase? (circle one)

1. Yes 2. No

What is your primary reason for this purchase? (circle one)

1. medical 2. weight loss 3. build muscle tone 4. burn calories
5. cardiovascular 6. healthy mind & body 7. other

Do you belong to a health club? (circle one)

1. Yes 2. No

What types of magazines do you commonly read? (circle all that apply)

1. fitness 2. sports 3. fashion 4. entertainment
5. inflight 6. women's / men's 7. political 8. health

M051-00K20-D002 (9/99)

UNPACKING INSTRUCTIONS

Step 1

Remove all staples from the corrugated shipping container and fold down the four sides of the base tray (A).

Step 2

Lift and open the top flaps of the shipping container sleeve (B). Lift and remove the two front support posts (C).

Step 3

With the help of another person, carefully lift the shipping container sleeve (B) up and off of the base tray (A) and over the Cross-Trainer (D). Remove the ship kit box (E) from the Cross-Trainer and set aside. Remove the remaining corner posts (F) and ship kit support (G).

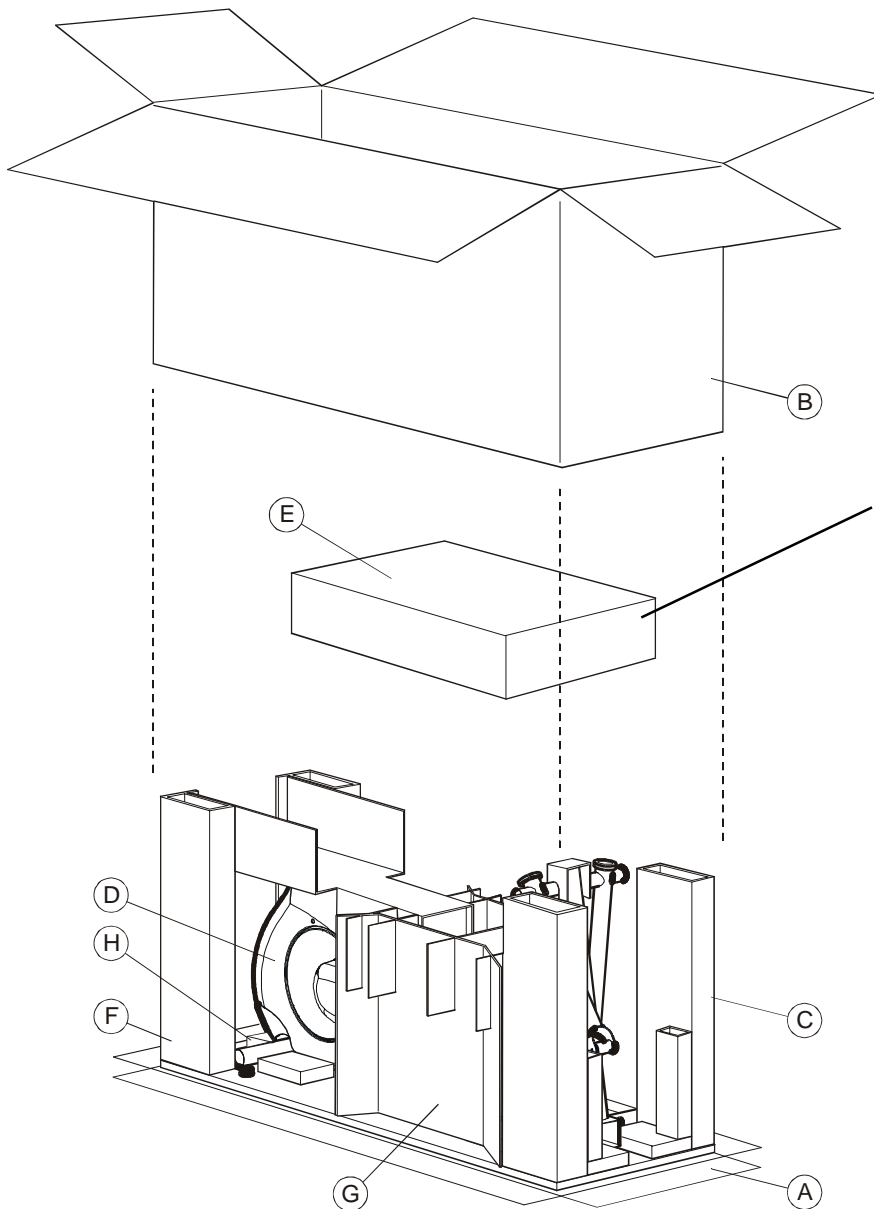

Step 4

Using a screwdriver, remove the rear locator pad (H) from the base tray (A).

Step 5

Carefully lift the front of the unit and slowly roll the unit backward beyond the flattened base tray.

Step 6

Follow the Installation Instructions included in the parts bag to complete the assembly of your Cross-Trainer.

Ship Kit Contents:

- Left & Right User Arms
- Console Support Assembly
- Left & Right Front Covers
- Display Console
- Front & Back Monocolumn Covers
- Hardware Kit
- Installation Instructions
- Polar Receiver Kit

(9100 / 9500HRR Only)

- Reading Rack Assembly

(9500HRR Only)

- Heart Rate Monocolumn Covers

(5500HR Only)

- Line Cord (International Only)

- Power Supply

- Polar Transmitter Kit

IMPORTANT
SAVE YOUR PACKING MATERIALS IN CASE OF RETURN



Cross-Trainer

ASSEMBLY INSTRUCTIONS

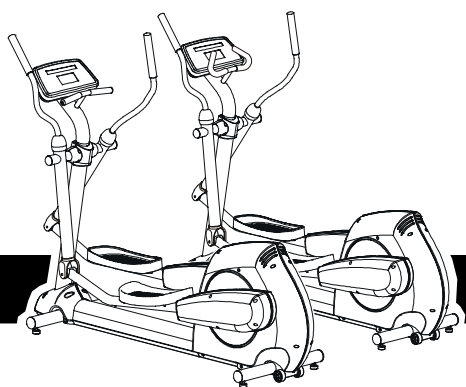

LifeFitness
Rely on it.™

Congratulations...

*and welcome to the world of **Life Fitness***

*and the **Life Fitness 5500HR / 8500 Cross-Trainers.***

The following Parts Identification Listing and the step by step assembly procedures have been assembled to make the set-up of the Cross-Trainer as quick and easy as possible.

Please take special note of the following important points prior to choosing a location and beginning assembly of the Cross-Trainer

IMPORTANT SAFETY INSTRUCTIONS!

DO NOT locate the Cross-Trainer outdoors, near swimming pools, or in areas of high humidity.

DO NOT operate your Cross-Trainer if it has been dropped, damaged, or even partially immersed in water. Contact Life Fitness Customer Support Services at the number in the Operation Manual.

DO NOT locate the Cross-Trainer any closer than 30 inches (76 cm) to a television set.

DO NOT locate additional Cross-Trainers any closer than a minimum of 42 inches (107 cm) from center to center to avoid interference (cross talk) between Heart Rate monitors.

DO keep the area around your Cross-Trainer clear of any obstructions, including walls and furniture.

DO verify the contents of the delivery carton against the accompanying Parts Listing prior to setting the cartons and shipping material aside. If any parts are missing, contact Life Fitness Customer Support Services at the number listed in the Operation Manual. Save the shipping cartons in case of return.

DO read the entire Operation Manual prior to attempting to operate this machine as this is essential for proper use.

TOOLS REQUIRED FOR ASSEMBLY... Magnetic Bit Phillips Screwdriver (provided), Hex Key Wrench (provided)

PARTS DESCRIPTION

1	Hex Key Mounting Bolt 0017-00101-1645	Qty: 8
3	Mounting Screw 0017-00101-1242	Qty: 10
5	Front Monocolumn Cover OK61-06020-0002	Qty: 1
7	Console Support Assembly AK61-00500-0002 (Model 5500HR) AK61-00500-0003 (Model 8500)	Qty: 1
9	Left Front Cover OK61-06200-0000	Qty: 1
11	Left User Arm Assembly AK61-00460-0001	Qty: 1
13	Power Supply (Model 5500HR Only) 118E-00001-0113 (Domestic)(A) 118E-00001-0114 (International)(B)	Qty: 1
15	Foam Isolator (Polar® Receiver) OK36-01059-00002	Qty: 1

2	Display Console Screw 0017-00101-1148	Qty: 4
4	Console Assembly AK61-00022-0001	Qty: 1
6	Back Monocolumn Cover OK61-06010-0002	Qty: 1
8	Flat Washer 0017-00104-0192	Qty: 2
10	Right Front Cover OK61-06210-0000	Qty: 1
12	Right User Arm Assembly AK61-00460-0000	Qty: 1
14	Polar® Receiver AK40-00045-0001	Qty: 1
16	Console Spacer OK61-05009-0000	Qty: 1

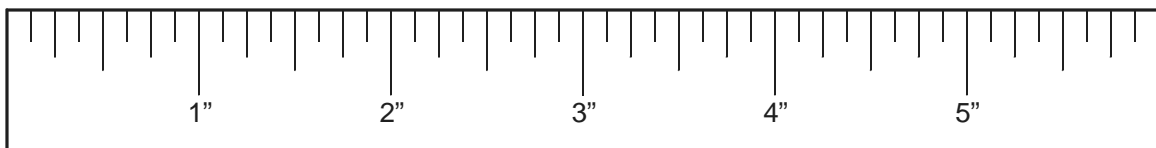
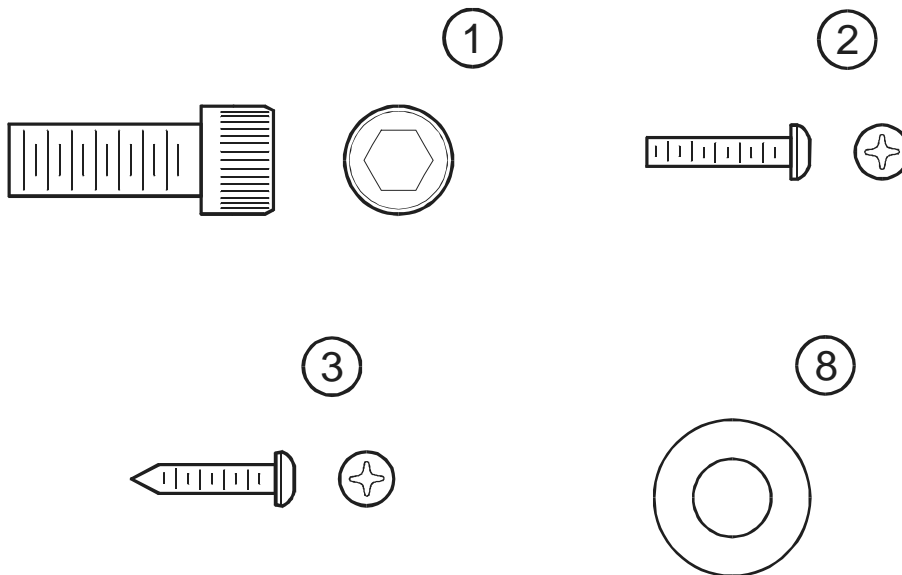

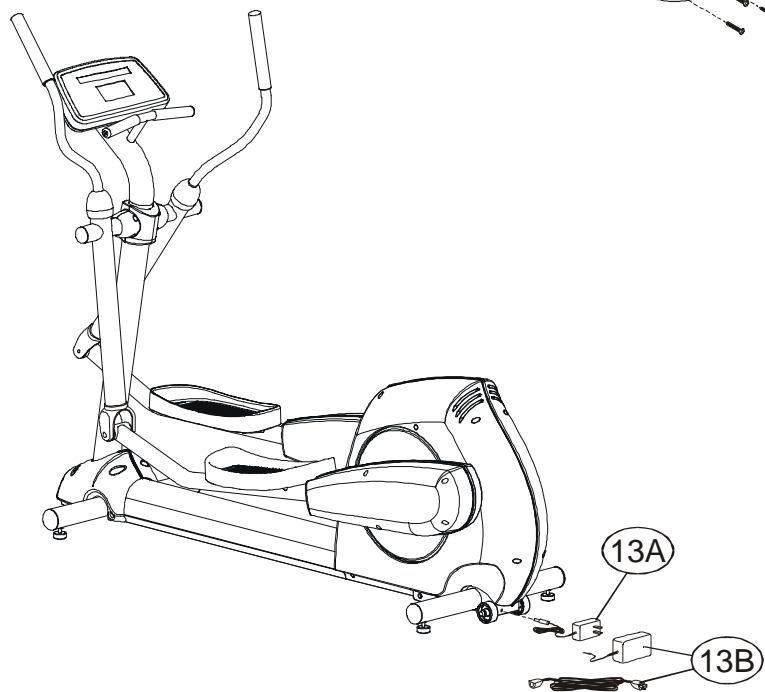
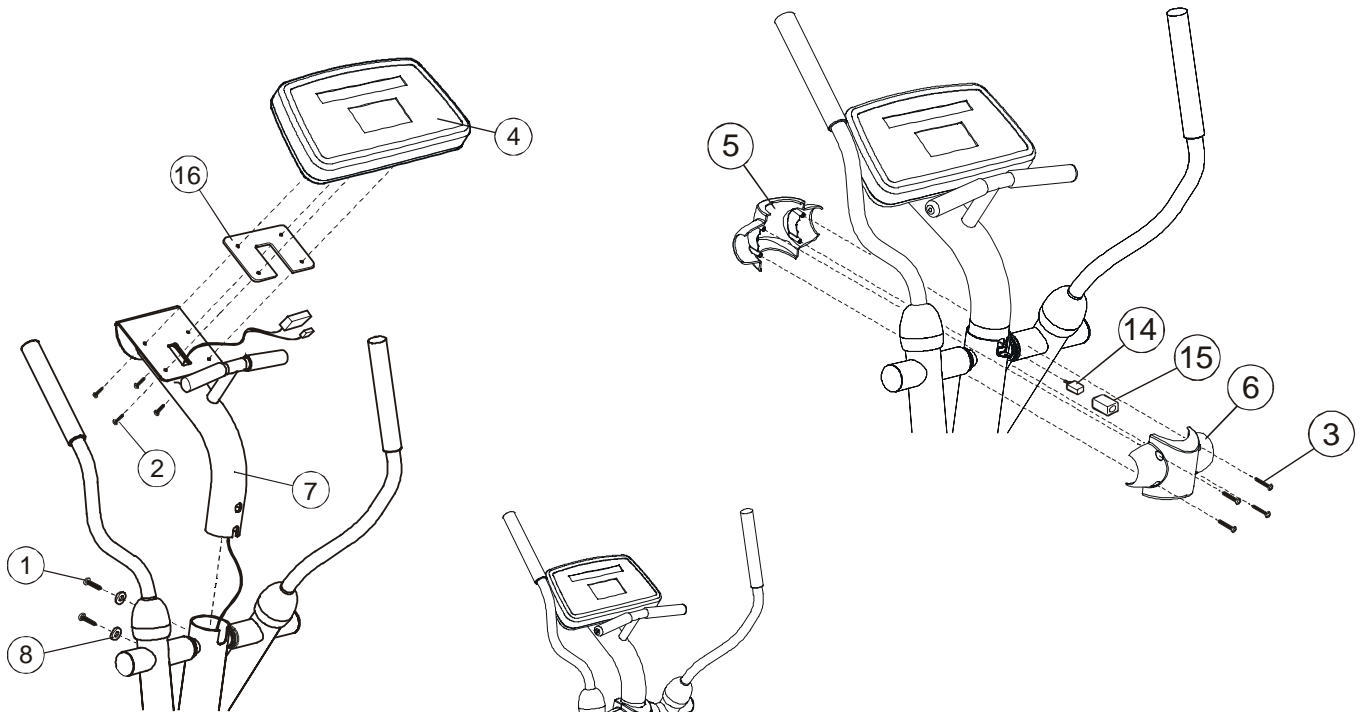
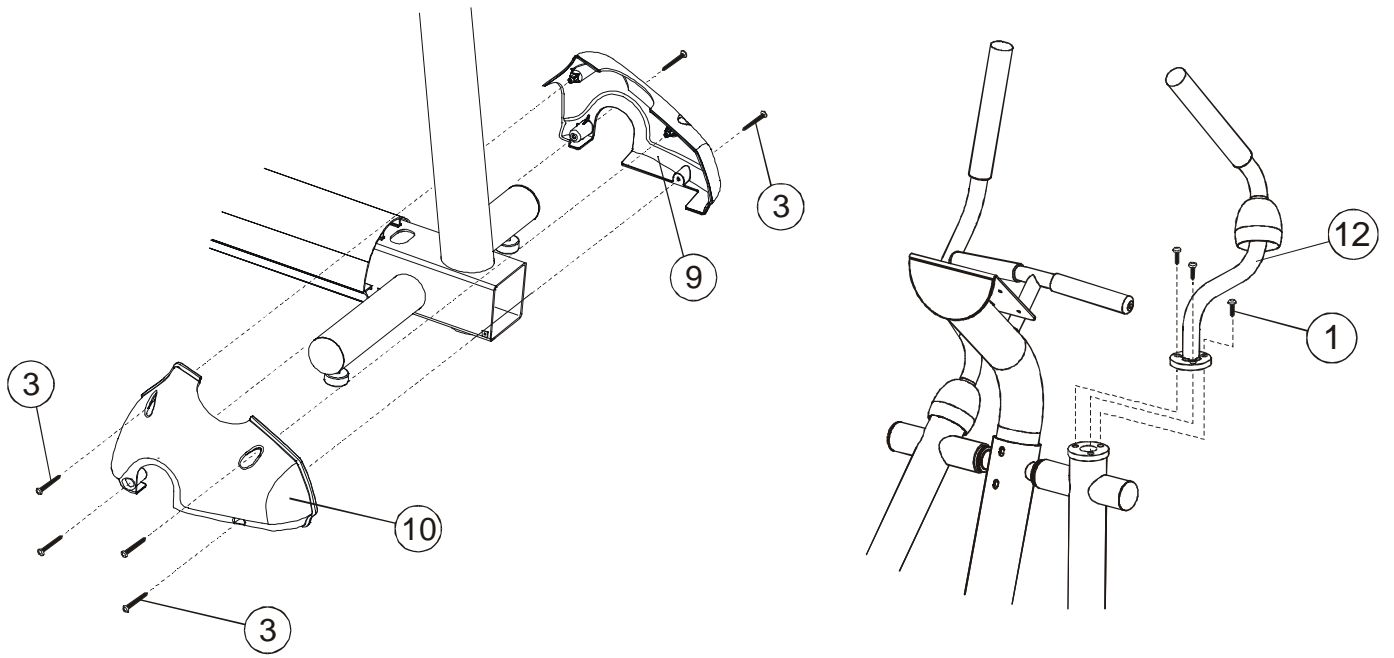

Step 1

Before proceeding, familiarize yourself with the parts of the Cross-Trainer and make sure that you have received all the items described in the Parts List.

Step 2

Locate the left and right FRONT COVER (#9, #10). Using two MOUNTING SCREWS (#3), mount the USER LEFT FRONT COVER (#9) to the FRAME (A). Attach the USER RIGHT FRONT COVER (#10) to the FRAME in the same manner using two MOUNTING SCREWS (#3). Secure the tops of the FRONT COVERS together using two MOUNTING SCREWS (#3).

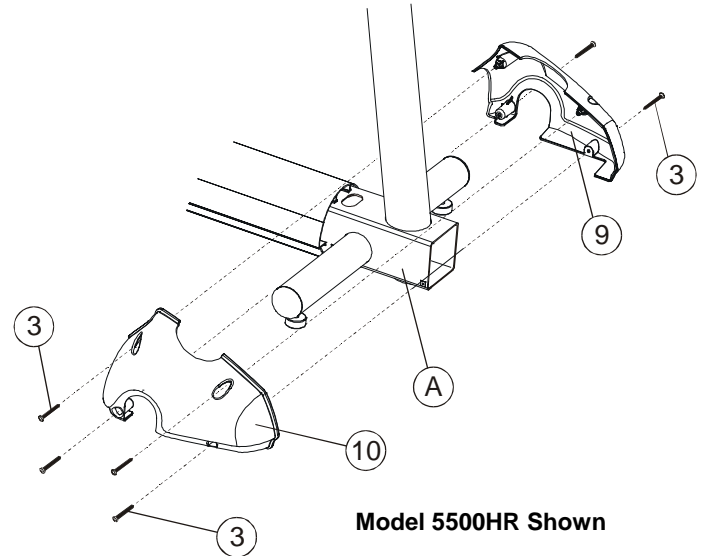

Step 3

Locate the LEFT USER ARM (#11). Secure the LEFT USER ARM to the LEFT ROCKER ARM (B) using three HEX KEY BOLTS (#1). Repeat the procedure for the RIGHT USER ARM (#12). Tighten all bolts securely. Lower the BOOT COVERS (C) down over the mounting plates.

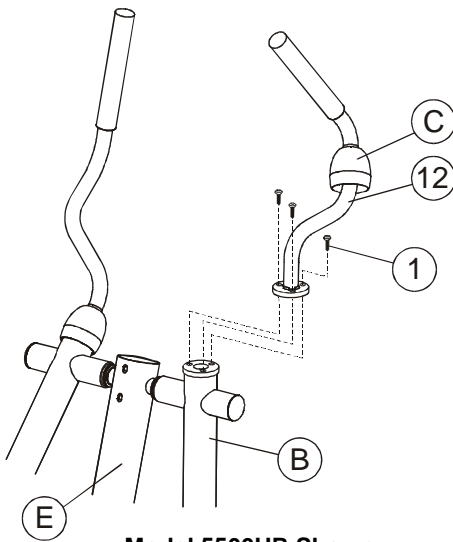

Step 4

Detach and unwrap the WIRE HARNESS located at the top of the MONOCOLUMN. Holding the CONSOLE SUPPORT ASSEMBLY (#7) with the handgrips facing upward, feed the WIRE HARNESS (D) up through the neck and out the top access hole. Carefully lower the CONSOLE SUPPORT ASSEMBLY onto the MONOCOLUMN.

CAUTION: BE CAREFUL NOT TO PINCH THE WIRE HARNESS WHEN ASSEMBLING THE CONSOLE SUPPORT ASSEMBLY (#7) TO THE MONOCOLUMN (E).

Step 5

Using two HEX KEY BOLTS (#1) and 2 FLAT WASHERS (#8), secure the CONSOLE SUPPORT ASSEMBLY to the MONOCOLUMN (E). Tighten the bolts securely.

Step 6

Attach the 3-PIN (3P) and 10-PIN (10P) CONNECTORS to the back of the CONSOLE ASSEMBLY.

Step 7

Place the CONSOLE ASSEMBLY SPACER (#16) onto the CONSOLE SUPPORT ASSEMBLY (#7). Align the mounting holes in the CONSOLE ASSEMBLY SPACER with those in the CONSOLE SUPPORT ASSEMBLY.

Step 8

Secure the CONSOLE ASSEMBLY (#4) to the CONSOLE SUPPORT ASSEMBLY (#7) using four MOUNTING SCREWS (#2). Tighten the screws securely.

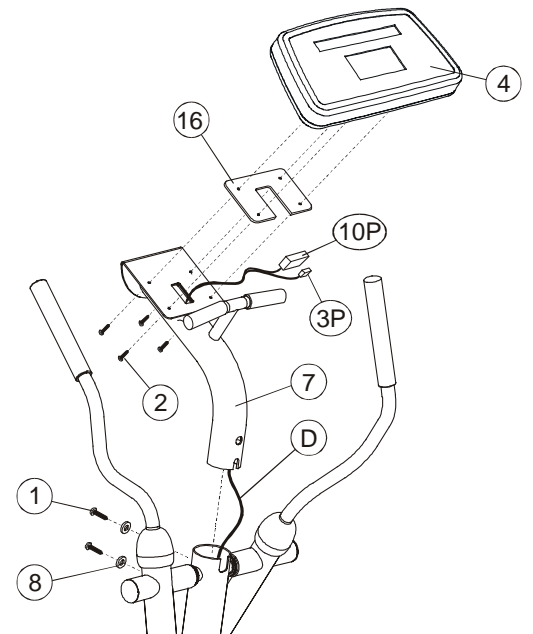

CAUTION: DO NOT OVER-TIGHTEN THE MOUNTING SCREWS (#3).

Model 5500HR Shown

Step 9 (Model 5500HR Only)

Locate the POLAR® RECEIVER (#14). Plug the POLAR RECEIVER into the jack located at the front of the MONOCOLUMN (E) near the DEAD SHAFT (F). Slide the FOAM ISOLATOR (#15) over the POLAR RECEIVER.

Step 10

Locate the front and back MONOCOLUMN COVERS (#5, #6). Place the FRONT MONOCOLUMN COVER (#5) over the PIVOT SHAFT (F) at the top of the MONOCOLUMN (E).

(Model 5500HR Only)

With the wire positioned on top, carefully insert the POLAR RECEIVER between the vertical ribs located inside the REAR MONOCOLUMN COVER.

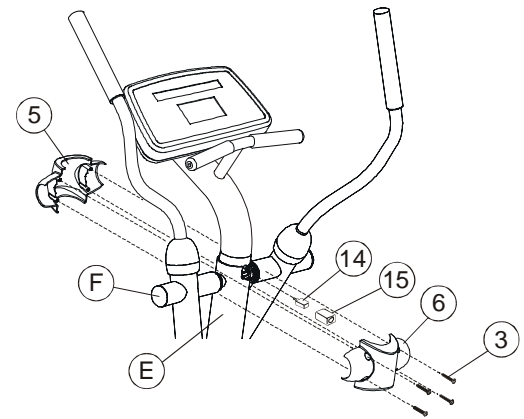

Model 5500HR Shown

NOTE: THE POLAR RECEIVER WIRE MUST BE BE POSITIONED ON TOP WHEN INSERTED INTO THE REAR MONOCOLUMN COVER.

Place the REAR MONOCOLUMN COVER (#6) on the opposite side of the FRONT MONOCOLUMN COVER to cover the PIVOT SHAFT and CONSOLE SUPPORT ASSEMBLY MOUNTING BOLTS. Use four MOUNTING SCREWS (#3) to secure the MONOCOLUMN COVERS together. Tighten the screws securely.

CAUTION: DO NOT OVER-TIGHTEN THE MOUNTING SCREWS (#3).

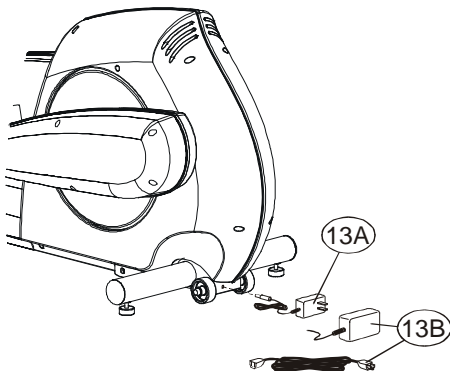

Step 11 (Model 5500HR Only)

Position the Cross-Trainer into the desired location for use. Locate the POWER SUPPLY (#13).

(Domestic Only)

Plug the connector end of the POWER SUPPLY (13A) into the Cross-Trainer at the lower rear of the unit. Plug the POWER SUPPLY into a wall outlet.

(International Only)

Plug the connector end of the TRANSFORMER (13B) into the Cross-Trainer at the lower rear of the unit. Plug the LINE CORD into the TRANSFORMER. Plug the pronged end of the LINE CORD into a wall outlet.

CAUTION: REFER TO THE OPERATION MANUAL FOR PROPER LINE CORD USAGE.

PRE-OPERATION CHECKLIST

- ✓ *Ensure that the USER ARM bolts are tight.*
- ✓ *Make sure the CROSS-TRAINER is properly leveled and stable.*
- ✓ *Ensure that the Leveler Jam Nuts are tight.*
- ✓ *Read the entire Operation Manual before using the Cross-Trainer.*

Before attempting to operate your Cross-Trainer, it is imperative that you familiarize yourself with the contents of the Operation Manual. If your Cross-Trainer does not respond as described in the OPERATION MANUAL, contact the nearest Life Fitness service center as listed in the Operation Manual.

LifeFitness
Rely on it.TM

Copyright 1999 Brunswick Corporation. All rights reserved. Life Fitness is a trademark of Brunswick Corporation.
Polar is a registered trademark of Polar Electro, Inc.

M051-00K20-A167

8/99

Corporate Headquarters

10601 West Belmont Avenue
Franklin Park, Illinois 60131

U.S.A.

847.288.3300 • FAX: 847.288.3703

800.735.3867 (Toll-free within the U.S. and Canada)

International Offices

LIFE FITNESS ASIA PACIFIC LTD

12th Floor, Tower 1, The Gateway
25 Canton Road
Tsimshatsui, Kowloon
HONG KONG
Telephone: 852.2.891.6677
FAX: 852.2.575.6001

LIFE FITNESS ATLANTIC BV

Atlantic Headquarters
Columbusstraat 25
3165 AC Rotterdam
NETHERLANDS
Telephone: 31.10.294.5011
FAX: 31.10.294.5029

LIFE FITNESS DO BRAZIL

Av. Rio Negro, 1084-11A-sala117.
Alphaville-Barueri
Sao Paulo
BRAZIL
Telephone: [55] 11.7295-2217
FAX: [55] 11-7295-2218

LIFE FITNESS AUSTRIA

Vertriebs GmbH
Hintschiggasse 1
1100 Vienna
AUSTRIA
Telephone: 43.1.61 57 198
FAX: 43.1.61 57 198.20

LIFE FITNESS BENELUX NV

Lambrechtshoekenlaan 309-311
B-2170 Antwerpen-Merksem
BELGIUM
Telephone: 32.3.644.4488
FAX: 32.3.644.2480

LIFE FITNESS EUROPE GMBH

Siemensstrasse 3
85716 Unterschleissheim
GERMANY
Telephone: 49.89.31 77 51.0
FAX: 49.89.31 77 51.99

LIFE FITNESS ITALIA S.R.L.

Via Elvas 92
39042 Bressanone (BZ)
ITALY
Telephone: 39.472.835 470
FAX: 39.472.833 150

LIFE FITNESS LATIN AMERICA

10601 West Belmont Avenue
Franklin Park, Illinois 60131
U.S.A.
Telephone: 847.288.3675
FAX: 847.288.3762

LIFE FITNESS UK LTD

Queen Adelaide
Ely, Cambs CB7 4UB
UNITED KINGDOM
Telephone: 44.1.353.666 017
FAX: 44.1.353.666 018

Before using this product, it is essential that this ENTIRE operation manual and ALL installation instructions be read.

This will help in setting up the equipment quickly and in instructing others on how to use it correctly and safely.

FCC Warning - Possible Radio / Television Interference

NOTE: This equipment has been tested and found to comply with the limits for a Class B digital device, pursuant to part 15 of the FCC rules. These limits are designed to provide reasonable protection against harmful interference in a residential installation. This equipment generates, uses and can radiate radio frequency energy, and if not installed and used in accordance with the instructions, may cause harmful interference to radio communications. However, there is no guarantee that the interference will not occur in a particular installation. If this equipment does cause harmful interference to radio or television reception, which can be determined by turning the equipment off and on, the user is encouraged to try to correct the interference by one or more of the following measures:

- Reorient or relocate the receiving antenna.

- Increase the separation between the equipment and the receiver.

- Connect the equipment into an outlet on a circuit different from that to which the receiver is connected.

- Consult the dealer or an experienced radio/TV technician for help.

Class H (Home): Domestic use.

CAUTION: Any changes or modifications to this equipment could void the product warranty!

Any service, other than cleaning or user maintenance, must be performed by an authorized service representative. There are no user serviceable parts.

TABLE OF CONTENTS

Section	Description	Page
1.	Getting Started	5
1.1	Important Safety Instructions	5
1.2	Set-up	6
2.	The Display Console	7
2.1	Display Console Overview	7
2.2	Display Console Descriptions	7
2.3	The Accessory Tray / Reading Rack	8
3.	Heart Rate Zone Training® Exercise	9
3.1	Why Heart Rate Zone Training Exercise	9
3.2	Heart Rate Monitoring.....	9
4.	The Workouts.....	10
4.1	Workout Overviews	10
4.2	Using the Workouts	11
	Select Quick Start // Select Workout Program	
4.3	Workout Descriptions	12
	Fat Burn // Cardio // Hill // Random // Manual // Cross-Train Aerobics // Cross-Train Reverse	
4.4	Workout Modes	14
4.5	Adjusting the Intensity Level	15
5.	Internal Settings	16
5.1	Default Settings	16
5.2	User's Custom Settings	17
6.	Service And Technical Data	19
6.1	Preventive Maintenance Tips	19
6.2	Preventive Maintenance Schedule	19
6.3	Troubleshooting the Heart Rate Chest Strap.....	20
6.4	How to Obtain Product Service.....	21
7.	Specifications	22
7.1	Life Fitness 5500HR Cross-Trainer Specifications	23

© 1999 Life Fitness, a division of Brunswick Corporation. All rights reserved. Life Fitness, and Heart Rate Zone Training exercise are registered trademarks, and Life Pulse and "Rely on It" are trademarks of Brunswick Corporation. Polar is a registered trademark of Polar Electro, Inc. Cardio Theater is a registered trademark of the Cardio Theater Holdings. Fitlinx is a registered trademark of the Integrated Fitness Corp. Any use of these trademarks, without the express written consent of Life Fitness or the corresponding companies is forbidden.

This Operation Manual describes the functions of the following products:

Life Fitness Cross-Trainer:

5500HR

See “Specifications” page in this manual for product specific features.

Life Fitness **STRONGLY** recommends seeing a physician for a complete medical exam before undertaking an exercise program, particularly if the user has a family history of high blood pressure or heart disease, or is over the age of 45, or smokes, has high cholesterol, is obese, or has not exercised regularly in the past year.

If, at any time while exercising, the user experiences faintness, dizziness, pain, or shortness of breath, he or she must stop immediately.

1 GETTING STARTED

1.1 IMPORTANT SAFETY INSTRUCTIONS

To reduce the risk of electrical shock, always unplug this Life Fitness product before cleaning or attempting any maintenance activity.

To reduce the risk of burns, fire, electric shock or injury, it is imperative to connect each product to a properly grounded electrical outlet.

- Never operate a Life Fitness product if it has a damaged power cord or electrical plug, or if it has been dropped, damaged, or even partially immersed in water. Contact Life Fitness Customer Support Services.
- Position this product so the power cord plug is accessible to the user.
- Keep the power cord away from heated surfaces. Do not pull the equipment by the power cord or use the cord as a handle. Do not run the power cord on the floor under or along the side of the Cross-Trainer.
- If the electrical supply cord is damaged it must be replaced by the manufacturer, an authorized service agent, or a similarly qualified person to avoid a hazard.
- Do not use this product in areas where aerosol spray products are being used or where oxygen is being administered. Such substances create the danger of combustion and explosion.
- Always follow the console instructions for proper operation.
- Close supervision is necessary when used by children, invalids or disabled persons.
- Do not use this product outdoors, near swimming pools or in areas of high humidity.
- Never operate a Life Fitness product with the air openings blocked. Keep air openings free of lint, hair or any obstructing material.
- Never insert objects into any opening in this product. If an object should drop inside, turn off the power, unplug the power cord from the outlet and carefully retrieve it. If the item cannot be reached, contact Life Fitness Customer Support Services.
- Never place liquids of any type directly on the unit, except in the optional accessory tray or holder. Containers with lids are recommended.
- Wear shoes with rubber or high-traction soles. Do not use shoes with heels, leather soles, cleats or spikes. Make sure no stones are embedded in the soles.
- Keep all loose clothing, shoelaces and towels away from moving parts.
- Do not use this product in bare feet.
- Do not reach into or underneath the unit while it is plugged in.
- Do not tip the unit on its side during operation.
- Keep the area around the Life Fitness product clear of any obstructions, including walls and furniture. Ensure that there is at least one foot clearance in front of the Cross-Trainer.
- Use caution when mounting or dismounting the Cross-Trainer. Use the stationary handlebar whenever additional stability is required. While exercising, hold onto the user arms.
- Never use the Cross-Trainer while facing backwards.

SAVE THESE INSTRUCTIONS FOR FUTURE REFERENCE

1.2 SETUP

Read the Operation Manual before setting up the Life Fitness Cross-Trainer.

1.2.1 WHERE TO PLACE THE CROSS-TRAINER

Following all Safety Instructions, position the Cross-Trainer where it will be used. When correctly positioned, the Cross-Trainer can be easily mounted from the side and the six foot power adapter cord can be plugged into the back of the Cross-Trainer without binding or being routed across a walkway. Allow 1 foot of clearance in front of the Cross-Trainer to allow for movement of the pedal lever.

1.2.2 HOW TO STABILIZE THE LIFE FITNESS CROSS-TRAINER

After placing the Cross-Trainer where it will be used, check its stability. If there is a rocking motion, even if slight, the unit needs to be stabilized. To level it, check the stabilizing feet on the stabilizing bars to determine which one does not rest fully on the floor. Using a finger, rotate this stabilizing to lower it. Recheck the stability and adjust again as needed until the Cross-Trainer is stable and no longer rocks. The adjustment may be locked into position by tightening the jam nut against the stabilizer bar with an open end 9/16 inch wrench.

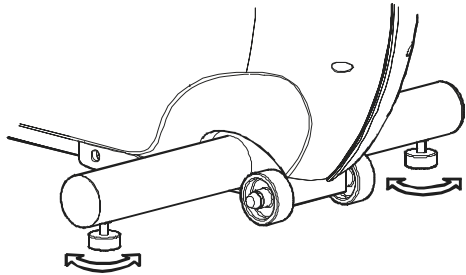

1.2.3 PLUG IN THE CROSS-TRAINER

The Life Fitness Cross-Trainer comes with a standard power supply for the U.S., or a universal power supply that will accept country-specific line cords.

Insert the power adapter jack into the barrel plug on the back of the Cross-Trainer. Then insert the transformer into the wall outlet (or the universal power supply if outside the U.S.). Make sure the cord is routed so that it doesn't bind and will not be walked on.

Check that the console LEDs light up. If not, recheck the plug and wall connections or make sure the wall outlet has power.

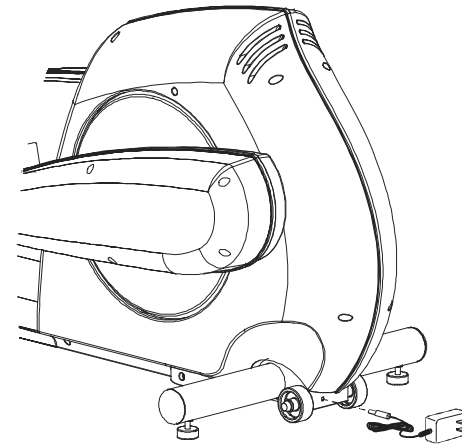

2 THE DISPLAY CONSOLE

2.1 DISPLAY CONSOLE OVERVIEW

The computerized display console is easy to use. It allows an individual to follow the progress of a workout. The on-board computer allows a workout to be tailored to individual fitness capabilities and goals while providing a unique means of measuring fitness improvement from one workout to the next.

2.2 DISPLAY CONSOLE DESCRIPTIONS

- A **ENTER:** This key is used to enter data displayed in the message center.
- B **THE ARROW KEYS:** Use the Up and Down Arrow keys to set the workout program parameters, including length of workout, weight, age, target heart rate, and resistance level. They can also be used to increase or decrease the effort level (or target heart rate if in the Fat Burn or Cardio programs) of a program while it is in progress.
- C **QUICK START:** Allows a user to begin a manual workout quickly, with minimal console inputs.
- D **PAUSE:** Press this key during a workout to pause it. Press it again (or resume pedaling) to reactivate the workout.
- E **CLEAR:** Press this key to clear incorrect data before pressing the ENTER key. Pressing Clear during a workout will end it and show a summary of the workout (total time elapsed, total calories, and distance traveled). Pressing it a second time will prompt for a new workout.
- F **DISPLAY LOCK:** This key allows freezing the message center display on one set of feedback information. To unlock the display, simply push the Display Lock key again.

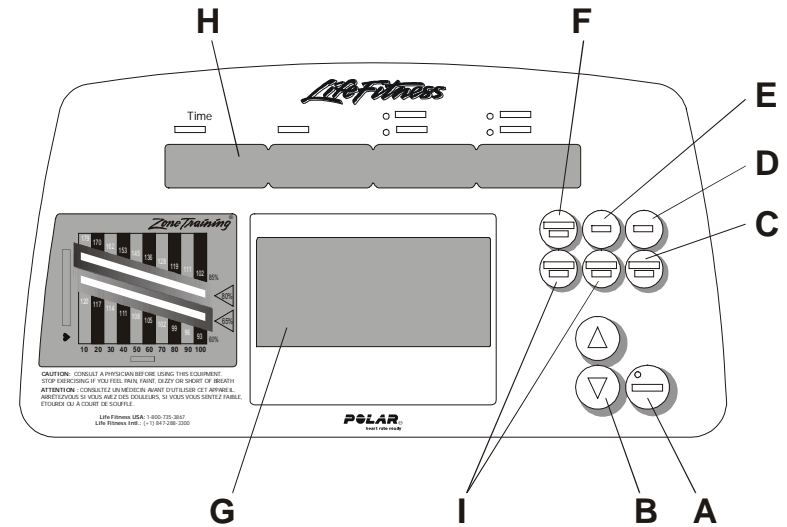

- G **WORKOUT PROFILE WINDOW:** Displays a matrix of lights displaying the current position and the upcoming terrain. While pedaling, the light columns move across the screen from right to left. The higher the column of lights, the greater the workout intensity.

Fat Burn and Cardio are interactive workouts which require use of the Polar® telemetry heart rate chest strap provided with the unit. During these workouts, a heart is displayed in the window at specific points in the workout when the heart rate signal is needed. If the signal is not detected, a message will appear, "NEED HEART RATE – CHECK TELEMETRY STRAP." If the heart rate signal isn't received within 3 minutes, the workout is converted to a Manual workout.

H **MESSAGE CENTER:** Provides simple step-by-step instructions during workout programs. It also displays the following feedback information:

Time displays the time elapsed since beginning the program.

RPM displays the number of pedal revolutions per minute.

Level displays the programmed resistance level. Level is lit only when the Level is changed, and remains on for 3 seconds.

Calories displays the calculated number of calories burned since beginning the program. Calories remains on and toggles to Level only when a change in Level is made.

Heart Rate displays the detected heart rate. If none is detected, only Distance is displayed. Heart Rate toggles to Distance whenever Distance increases another tenth mile.

Distance displays the equivalent distance traveled since beginning the program, based on the RPM and level. Distance toggles to Heart Rate (if detected) after 5 seconds.

I **MODE KEYS:** Two modes are provided:

Aerobics Mode displays prompts on the Message Center to vary the workload and emphasize different muscle groups during the workout. It can be used with the Hill, Random and Manual programs.

Reverse Mode varies the workout by alternating 5 minutes of forward motion with two minutes of reverse motion. It can be used with the Hill, Random and Manual programs.

2.3 THE ACCESSORY TRAY / READING RACK

The optional accessory tray with reading rack supports a water bottle and portable cassette or CD player. It mounts under the console.

The reading rack supports a magazine or book at the bottom edge of the console.

Call the numbers listed in "How to Obtain Product Service" to order this or other parts and accessories.

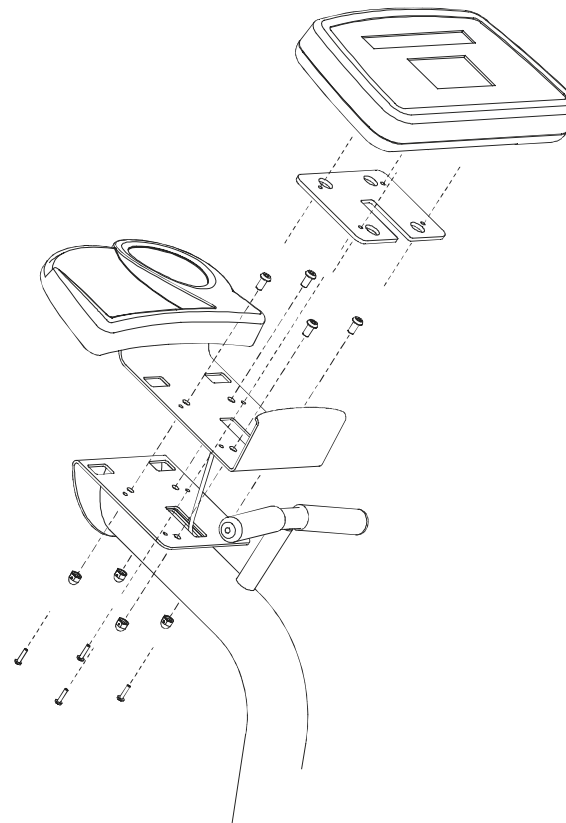

3 HEART RATE ZONE TRAINING® EXERCISE

3.1 WHY HEART RATE ZONE TRAINING EXERCISE?

Research shows that exercising within a specific heart rate is the optimal way to monitor exercise intensity and achieve maximum results. That is the idea behind the Life Fitness Heart Rate Zone Training approach to exercise.

Zone Training Exercise takes the guesswork out of working out by identifying specific ranges, or zones, in which to maintain a heart rate to achieve maximum exercise results according to goals. In short, Zone Training Exercise all but eliminates under- and over-training by targeting heart rate to individual fitness objectives.

For instance, if the primary goal is to burn fat, exercise at a level between 60% and 75% of the theoretical maximum heart rate[†]. To improve cardiovascular condition, work out at 75% to 85% of the theoretical maximum heart rate.

Life Fitness offers two exclusive workouts designed to take full advantage of the benefits of Heart Rate Zone Training Exercise: Fat Burn and Cardio. The focus of the exercise activities can be varied by switching between the Fat Burn and Cardio workouts at any time during a workout or by entering a new target heart rate with the Up or Down Arrow keys.

Both the Fat Burn and Cardio workouts measure heart rate. Wear the telemetry heart rate chest strap and the heart rate will be transmitted to the on-board computer continuously. The resistance level will automatically adjust to maintain the target heart rate based on the actual heart rate.

[†] Defined by the American College of Sports Medicine's "Guidelines for Exercise Testing and Prescription" as 220 minus the user's age.

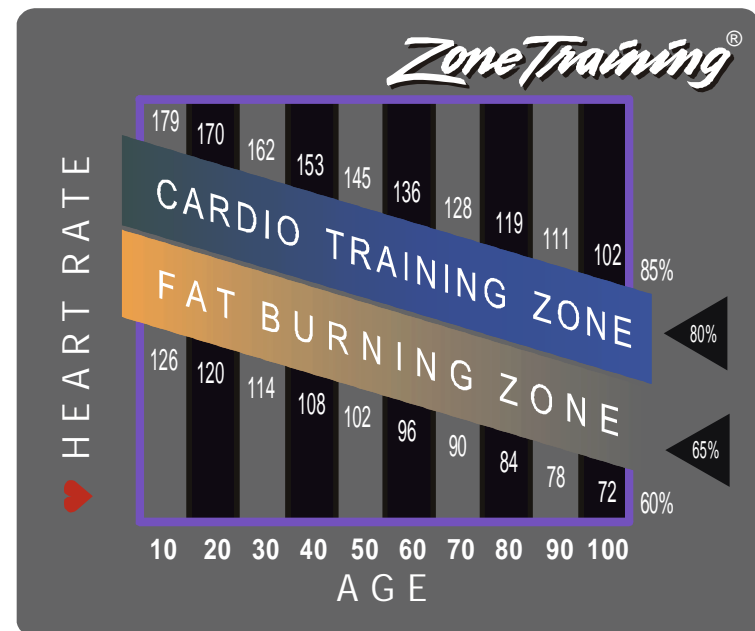

3.2 HEART RATE MONITORING

THE HEART RATE CHEST STRAP

The heart rate chest strap allows the on-board, Polar® telemetry heart rate feature of this product to continuously monitor the heart rate and in many workouts adjusts aspects of the workout such as resistance level.

Wet the transmitter electrodes (the two grooved surfaces on the underside of the strap) and secure the strap as high under the chest muscles as possible. The strap should be snug, but comfortable enough to allow for normal breathing.

The transmitter strap will deliver an optimum heart rate reading when the electrodes are directly in contact with bare skin. However, it will function properly through wet, lightweight clothing.

The key to proper operation is for the electrodes to remain wet to transmit the electrical impulses of the heart back to the receiver.

If it becomes necessary to remoisten the chest strap electrodes, grasp the center of the strap, pull it away from the chest to expose the two electrodes, then moisten them in this position.

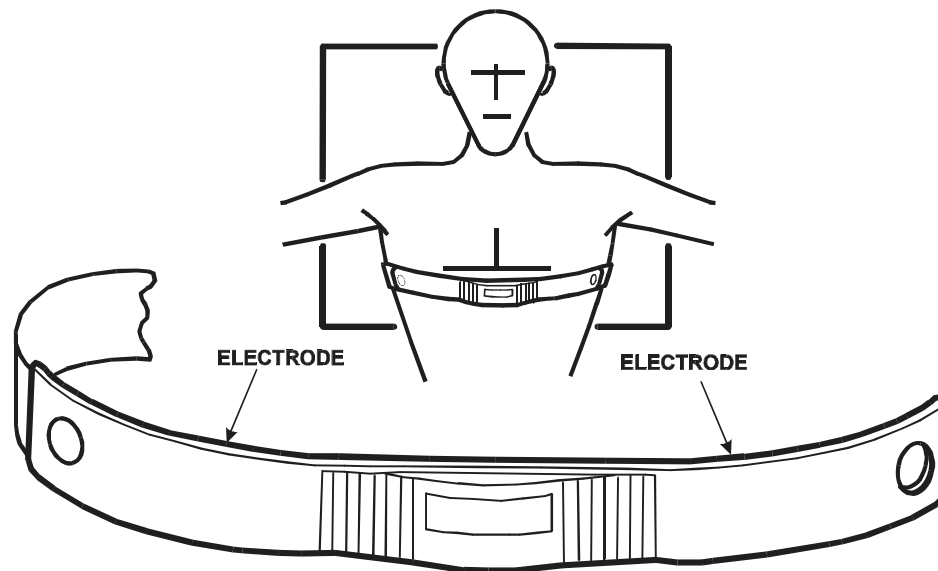

4 THE WORKOUTS

4.1 WORKOUT OVERVIEWS

Selecting a Life Fitness workout is as easy as pressing a key. The following are preprogrammed workouts for this Life Fitness product.

QUICK START is the fastest way to begin exercising. It allows starting a manual workout with minimal console input.

FAT BURN is a workout offering a low intensity way to burn fat. The heart rate chest strap must be used. The Fat Burn workout automatically changes the resistance level to maintain the heart rate at 65% of theoretical maximum.

CARDIO is a higher intensity workout emphasizing cardiovascular benefits and maximum fat burning for more fit users. The heart rate chest strap must be used. The Cardio workout will automatically change the resistance level to maintain the heart rate at 80% of theoretical maximum.

HILL is an interval training workout consisting of a combination of hills and valleys proven to provide effective, time-efficient cardiovascular results.

RANDOM is an interval training workout of varying resistance levels which occur randomly with each exercise session.

MANUAL is a constant effort workout in which the user can change resistance level or speed at any time.

CROSS-TRAIN AEROBICS is a versatile workout which acts like a personal trainer, prompting the user to try pushing, pulling, total body, lower body, speed changes, and forward/reverse motion. This workout allows maximum cross-training benefits.

CROSS-TRAIN REVERSE is a workout alternating forward motion (5 minutes) and backward motion (2 minutes), thereby cross-training different muscle groups.

4.2 USING THE WORKOUTS

To begin a workout, first check that the Message Center is scrolling “PRESS ENTER TO BEGIN.” If it displays a different message, press the Clear key twice in rapid succession.

SELECT QUICK START

Quick Start is the fastest way to begin exercising, allowing a manual workout to begin with minimal console input. To use it, press the Quick Start key, then use the arrow keys to set the weight.

SELECT WORKOUT

First, press Enter. The Message Center now prompts for the weight (default is 150 pounds or 68 kilograms).

Second, enter weight. Use the Up and Down Arrow keys to set the weight as required and press the Enter again. Now the workout program can be selected.

Third, select a workout. The first workout shown is Fat Burn. For a different workout, use the Up and Down Arrow keys to scroll through the choices (see below). Then press Enter.

Fourth, complete workout setup. The Message Center prompts for the remaining setup information required for the workout: the planned workout length and resistance level, or the age and target heart rate. Use the Up and Down Arrow keys to increase or decrease the default values for each, then press the Enter key.

REMEMBER: The Arrow keys can be used at any time during a workout to change the resistance level or the Target Heart Rate.

FAT BURN

Enter Time
Enter Age
Enter Target Heart Rate[†]
Begin Workout

CARDIO

Enter Time
Enter Age
Enter Target Heart Rate[†]
Begin Workout

MANUAL

Enter Time
Enter Level
Begin Workout

RANDOM

Enter Time
Enter Level
Begin Workout

HILL

Enter Time
Enter Level
Begin Workout

CROSS-TRAIN AEROBICS

Enter Time
Enter Level
Begin Workout

CROSS-TRAIN REVERSE

Enter Time
Enter Level
Begin Workout

[†] The Target Heart Rate is calculated based upon the age and can be modified according to the user's personal physical condition.

4.3 WORKOUT DESCRIPTIONS

FAT BURN WORKOUT

The Fat Burn workout brings the benefits and results of Heart Rate Zone Training Exercise to users on a daily basis.

On featured Life Fitness cardiovascular equipment, the Fat Burn workout uses the technology of heart rate monitoring (via an optional heart rate chest strap or the Lifepulse System) to help maintain a specific heart rate (65% of a theoretical maximum heart rate[†]) within a target zone based on age. This maximizes the aerobic benefits of exercise by accessing the body's fat stores for fuel.

The result is a perfect workout every time, eliminating both under- and over-training. Concentration is centered on the workout, because the Life Fitness product responds to the heart rate and adjusts the workout to maintain the target heart rate.

CARDIO WORKOUT

The Cardio workout is virtually identical to the Fat Burn workout. The only difference is that the target heart rate is calculated at 80% of the theoretical maximum heart rate[†] to accentuate cardiovascular improvement by placing a heavier workload on the heart muscle.

To vary the focus of exercise activities, transfer between the Fat Burn and Cardio workouts at any time during a workout.

[†] Defined by the American College of Sports Medicine's "Guidelines for Exercise Testing and Prescription" as 220 minus the user's age.

[‡] Using the heart rate chest strap and telemetry receiver.

HILL WORKOUT

The Life Fitness patented Hill workout offers the ideal configuration for interval training: periods of intense aerobic activity separated by regular intervals of lower-intensity exercise. The computerized interval training workout has been scientifically demonstrated to yield greater cardiorespiratory improvement than steady-pace training. Not only does the Hill workout offer the challenge of alternating periods of high and low intensity, but the levels of intensity become progressively more difficult during the course of the workout. The longer the Hill workout, the more amount of time spent on top of a hill and at the bottom of a valley.

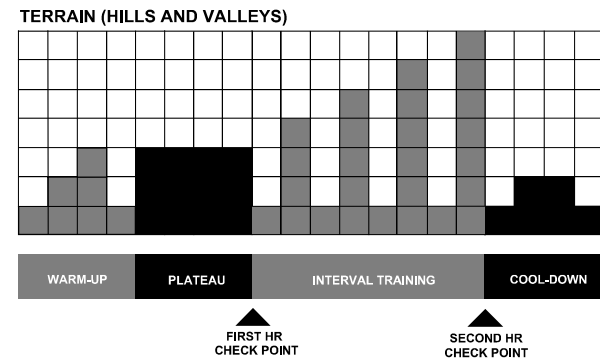

PHASES

Each Hill workout session comprises the following phases: (1) Warm-up, (2) Plateau, (3) Interval Training, and (4) Cool-down.

NOTE: Check the pulse at the Heart Rate (HR) Check Points (following the Plateau and Interval Training phases) to ensure that the heart rate has entered and remained within the target heart rate zone.

Warm-up: Gradually brings the heart rate into the lower portion of the target heart rate zone, increasing respiration and blood flow to working muscles.

Plateau: Increases heart rate so that it is within target zone. Check the heart rate to ensure that it has entered the target zone.

Interval Training: A series of hills and valleys. During this portion of the workout, the user is confronted with a series of successively steeper hills, each separated from the next by a valley or recovery period. Check the heart rate to ensure that it has remained within the target zone.

Cool-down: The cool-down allows the body to begin removing accumulated by-products of exercise, such as lactic acid, which build up in muscles during a workout and contribute to muscle soreness.

Effort and recovery periods are simulated on the display console by columns of red lights in the workout Profile window. Each column represents one interval and 20 intervals comprise the workout. The columns move from right to left during the workout. The higher the column, the higher the resistance. Consequently, the effort must be increased to continue training.

1 to 9 minutes: Because workouts with durations of less than 10 minutes are insufficient for the Hill workout to complete all four phases adequately, the workout condenses at various stages in order to meet the chosen workout time.

10 to 19 minutes: The interval durations are initially set at 30 seconds for a 10-minute workout. For every additional minute of workout duration, the Hill workout lengthens each interval by three seconds. Thus, a 15-minute Hill workout will feature 20 intervals of 45 seconds each.

20 to 99 minutes: All intervals last 60 seconds. As minutes are added, additional hills and valleys are presented beyond the initial four of the interval training phase. The additional hills and valleys will follow the form of the first four, dropping back down to the level of the very first hill encountered and progressing in height every two minutes until the highest hill is reached again. This process repeats until the workout duration is met.

RANDOM AND MANUAL WORKOUTS

RANDOM WORKOUT

The Life Fitness on-board computer randomly selects hill and valley terrain which varies with each and every workout, resulting in more than one million combinations. Because workout levels are greater in this workout than in the Hill workout, it is recommended that the Random workout be set one or two levels lower than the workout level which would normally be selected in the Hill workout.

MANUAL WORKOUT

The Manual workout provides steady pace exercise with resistance levels equal to that of the highest hill encountered in the Hill workout at the same effort level. Because of the greater effort levels of this workout, it is recommended to set the Manual workout about three to four levels lower than the level of effort which would normally be selected on the Hill workout.

A personal interval training workout can be designed using the Manual workout by varying the level of effort during the course of the workout session. To do so, select a high level of effort until the upper end of the target heart rate zone is reached, then pedal at a lower effort level until the heart rate drops to the bottom of the target zone. Then increase the level of effort again until the heart rate rises back to the upper portion of the target zone. Repeating this process will actually create hills and valleys.

AEROBICS AND REVERSE WORKOUTS

CROSS-TRAIN AEROBICS WORKOUT

This workout makes the most of the Life Fitness Cross-Trainer's total body workout. While exercising, the computer console prompts the user to vary the workout.

For an upper body workout that works all the muscles in the arms, the console directs the user to push and pull the handlebar arms at various times. The console will also vary the workout between total body and lower-body-only workouts, during which the user rests his or her hands on the stationary handlebar.

To maximize lower-body workout, forward and reverse motions and speeds are alternated, working all the muscles in the legs in a variety of conditions in one exercise session.

This Cross-Trainer workout is a constant resistance workout. However, it is also available as a variable resistance workout by selecting the Hill, Manual or Random program first. Then, after starting the workout, press the Aerobics Mode key on the console.

CROSS-TRAIN REVERSE WORKOUT

To vary the Cross-Trainer exercise and to maximize the lower-body workout, the Cross-Train Reverse workout prompts the user to use a forward motion for five minutes followed by a backward motion interval for two minutes for a cross-training workout of different muscle groups. This workout makes the most of the Life Fitness Cross-Trainer's forward and reverse feature. While exercising, the computer console prompts the user to vary the workout.

This Cross-Trainer workout is a constant resistance program. However, it is also available as a variable resistance workout by selecting the Hill, Manual or Random program first. Then, after starting the workout, press the Reverse Mode key on the console.

4.4 WORKOUT MODES

THE AEROBICS MODE AND REVERSE MODE KEYS

Cross-Training Aerobics and Cross-Training Reverse are constant resistance workouts. However, the features of these workouts can be applied to variable resistance workouts by use of the Aerobics Mode and Reverse Mode keys.

TO SELECT WORKOUT MODE

Aerobics Mode applies the Cross-Train Aerobics workout features to one of the variable resistance workouts. To use it, select the Hill, Manual, or Random workout, and after it starts press the Aerobics Mode key. Pressing the Aerobics Mode key again will end Aerobics Mode and continue with the original workout.

Reverse Mode applies the Cross-Train Reverse workout features to the Hill, Manual, or Random workout. The workout will alternate forward motion (5 minutes) with reverse motion (2 minutes). To use it, select the Hill, Manual, or Random program, and after it starts press the Reverse Mode key. Pressing the Reverse Mode key again will end Reverse Mode and continue with the original workout.

4.5 ADJUSTING THE INTENSITY LEVEL

Workout intensity is adjusted at any time during the workout by using the arrow keys to increase or decrease either the resistance level or the target heart rate (Fat Burn and Cardio programs).

Changing level. The higher the level (between 1 and 20), the greater the resistance level applied during the workout. The height of the LEDs in the Workout Profile window represent the level of resistance applied to the pedals. Each successive LED represents a higher hill and greater resistance.

Changing target heart rate. The initial target heart rate† shown is based upon the entered age and the workout chosen (Fat Burn or Cardio). The user accepts or adjusts the specified target heart rate during the set-up process. During the workout, the heart rate is transmitted by the chest strap and is used to control the workout resistance in order to keep the user in the correct target heart rate zone. The user can adjust the target heart rate at any time during the workout, using the arrow keys.

† Defined by the American College of Sports Medicine's "Guidelines for Exercise Testing and Prescription" as 220 minus the user's age.

5

USER'S CUSTOM SETTINGS AND SYSTEM TEST

5.1 USER'S CUSTOM SETTINGS

User's Custom Settings allow changing some of the Cross-Trainer operational settings. Through these Settings, various operational parameters can be changed.

The User's Custom Settings and their associated default settings are listed below.

Configuration Setting	Factory Default	Description
	<u>CT 5500HR</u>	
SLEEP MODE DELAY:	OFF	Number of minutes before sleep mode begins. Can be disabled or adjusted from 1-255 minutes.
PAUSE TIMEOUT DURATION:	1 minute	Number of minutes user can pause a workout. Can be adjusted from 1-99 minutes.
TELEMETRY (ON/OFF):	ON	Telemetry allows the product to use the Polar® Heart Rate Zone Training exercise chest strap to monitor the heart rate.
ENGLISH/METRIC UNITS:	ENGLISH	The units of measure used by the equipment (e.g. miles or kilometers).
MAXIMUM WORKOUT DURATION:	60 minutes	The maximum duration of a workout. Can be adjusted from 60 to 99 minutes
STATISTICS:	-	Displays statistics on hours of use and programs used.

To access User's Custom Settings, exit any program so the Message Center displays "PRESS ENTER TO BEGIN." Instead of pressing Enter for a program, press the Up arrow key. "USER'S CUSTOM SETTINGS" will appear.

While in the User's Custom Settings, press Enter to scroll forward through each Setting option, or to exit after the last Setting. Alternately, press the Clear key to scroll backward through the Settings, or to exit at the start. Upon exiting, the Message Center is momentarily blank and then displays "PRESS ENTER TO BEGIN."

The User's Custom Settings are described below.

SLEEP MODE

While not in use, the Enter LED flashes on and off, the workout profile window displays a matrix of lights, and the Message Center continually scrolls the message PRESS ENTER TO BEGIN. The Cross-Trainer can be programmed to go into Sleep Mode instead while not in use. During Sleep Mode, the console LEDs turn off to conserve power. Only the Enter LED remains flashing on and off. When any key is pressed, the console becomes active again. The Cross-Trainer will go into Sleep Mode after a specified time delay.

The Sleep Mode setting is used to disable Sleep Mode or to enable it by setting the amount of time that must elapse before Sleep Mode begins. The value can be set between 1 and 255 minutes. The factory default setting is for Sleep Mode to be disabled (SLEEP MODE OFF).

To enable or disable Sleep Mode, or to change its delay value, enter the User's Custom Settings according to instructions and press the Enter key until the Message Center shows "SLEEP MODE" followed by the current value in minutes. If it shows OFF, then Sleep Mode is disabled.

To change the value, press the Up or Down Arrow key to increase or decrease the delay time. To enable Sleep Mode where it displays "OFF," press the Up arrow key and select the desired time delay for it to begin. To disable Sleep Mode (so that the console doesn't turn off), press the Down arrow key to set the delay less than 1, where "OFF" is displayed.

PAUSE TIMEOUT DURATION

The Pause Timeout Duration is the amount of time the Cross-Trainer will store an active program in memory after the PAUSE key has been pressed. The Cross-Trainer will also go into Pause automatically if pedaling stops.

While paused, the system-controlled resistance is no longer applied to the pedals and the display shows "PAUSED" alternately with the workout data. The user may press the Pause key and continue pedaling without resistance as a short break in the routine, if desired.

To resume the workout program, the user presses the Pause key again or simply resumes pedaling (if pedaling had ceased). The workout must be resumed before the pause duration times out.

The Pause Timeout Duration controls the amount of time the Cross-Trainer will remain paused. After the pause time is elapsed, the active program is cancelled and the console shows "PRESS ENTER TO BEGIN." The factory default value for Pause Timeout Duration is one minute. The value can be set from 1 minute up to a maximum of 99 minutes.

To change the Pause Timeout Duration value, enter the User's Custom Settings according to instructions and press the Enter key until the Message Center shows "PAUSE TIMEOUT" followed by the current timeout value in minutes. To change the value, press the Up or Down Arrow key to increase or decrease the duration.

TELEMETRY

The factory default setting is for Polar® telemetry to be enabled. When enabled, the Cross-Trainer detects signals transmitted from the heart rate chest strap.

To change the setting, enter User's Custom Settings and press the Enter key until the Message Center shows "TELEMETRY" with ON or OFF. To set telemetry ON, press the Up Arrow key. To set telemetry OFF, press the Down Arrow key.

ENGLISH/METRIC UNITS

The factory default setting for the display console measurements, such as weight and distance, is based upon either the English or Metric systems of measure. When set to English, measurements are based on miles and pounds. When set to metric, measurements are based on kilometers and kilograms.

To change the setting, enter User's Custom Settings and press the Enter key until the Message Center shows "ENGLISH" or "METRIC". To set the units to ENGLISH, press the Up Arrow key. To set the units to METRIC, press the Down Arrow key.

MAXIMUM WORKOUT DURATION

Maximum Workout Duration is the maximum amount of time that can be set for a workout program. It also controls the Quick Start session length. The factory default for this setting is 60 minutes. The value can be set from 60 minutes up to 99 minutes.

To change the Max Duration value, enter User's Custom Settings and press the Enter key until the Message Center shows "MAX DURATION" followed by the current timeout value in minutes. To change the value, press the Up or Down Arrow key to increase or decrease the duration.

STATISTICS

The Statistics show how many hours the Cross-Trainer has been used and how many times each of the workouts has been selected.

To access the Statistics data, enter User's Custom Settings and press the Enter key until the Message Center shows "STATISTICS." Each statistic is shown separately. To scroll through the statistics, use the arrow keys. The Up key will advance through the statistics, the Down key will go back.

HOURS = (total accumulated hours of usage)

HILL = (number of times this program was selected)

RANDOM = (number of times this program was selected)

MANUAL = (number of times this program was selected)

FAT = (number of times this program was selected)

CARDIO = (number of times this program was selected)

X-REV = (number of times this program was selected*)

X-AERO = (number of times this program was selected*)

QUICK = (number of times this mode was selected)

The statistics values cannot be changed.

* - The X-REV and X-AERO statistics reflect usage of the Cross-Train Reverse and Cross-Train Aerobics workouts. They do not reflect usage of the Aerobics and Reverse Mode keys during a Hill, Random or Manual workout.

5.2 SYSTEM TEST

System Test mode allows various system components to be tested to confirm proper operation.

To access System Test mode, exit any program so the Message Center displays "PRESS ENTER TO BEGIN." Instead of pressing Enter for a program, press and hold down the Display Lock key and press the Down Arrow key. The Message Center will scroll SYSTEM TEST.

While in System Test mode, press Enter to scroll forward through each Test, or to exit after the last Test. Alternately, press the Clear key to scroll backward through the Tests, or to exit at the start.

Upon exiting, the Message Center is briefly blank and then scrolls "PRESS ENTER TO BEGIN", resuming its normal function.

If any test fails or displays incorrect data, call Life Fitness Customer Service.

ALL LEDs AND KEYPAD TEST

All LEDs and Keypad Test checks that each LED is lit and each key on the console works and sends the correct signal when pressed.

Press each of the following keys in turn, and check that the Message Center displays the correct letter value for it:

KEY	Associated Alpha Character
DISPLAY LOCK	L
AEROBICS MODE	A
REVERSE MODE	R
QUICK START	Q
UP ARROW	U
DOWN ARROW	D
PAUSE	P

INDIVIDUAL LED TEST

In this test, the system automatically scrolls through each LED in the Message Center and Profile Window. During this test, all LEDs must cycle on and off. If any appear stuck, whether on or off, the LED is defective or the LED drive circuitry failed.

FUNCTIONAL TEST

This Test displays the following information:

Software Code Version. The software code version, a four-digit number, is displayed in the Time panel of the Message Center.

RPM. This is displayed in the RPM panel of the Message Center. Pedal the Cross-Trainer to check that it responds, showing the RPM value.

Heart Rate. This is displayed in the third panel (Level/Calories). If it displays HR, and the Heart Rate LED above the fourth panel is not lit, then the Cross-Trainer is not detecting any heart rate signal. Using the Polar[®] telemetry chest strap, check that the heart rate reading is displayed instead of the HR in the third panel and the Heart Rate LED above the fourth panel is lit.

Load Duty Cycle. The fourth panel displays the load duty cycle. It initially reads 0. Begin pedaling at a constant rate at least 45 RPM. While pedaling, press the Up Arrow key to check that the reading increases from 0 up to 250. Check that the pedal resistance increases accordingly. If so, the test is successful.

NOTE: Changes to pedal resistance apply only while in System Test mode and are cancelled upon exiting. Leave it set at 50 or 75 if Field and Alternator-Regulator will be tested.

Software Part Number. The Message Center displays the 13-digit Software Part Number across all four panels. Use the Display Lock key to toggle the Message Center between display of the Software Part Number and the other functional tests described above.

FIELD AND ALTERNATOR-REGULATOR TEST

This tests the Field Voltage and Alternator-Regulator lines to check for problems in pedal resistance. Follow the procedure below:

NOTE: Before beginning this test, set the Load Duty Cycle (one of the Functional Tests described above) to 50 or 75.

1. Press the Enter key until "FIELD/ALTREG TEST" is displayed.
2. Press the Display Lock key. The display will read FIELD. The initial value is OFF.
3. Enable Field Voltage. Use the Up Arrow key to change FIELD=OFF to FIELD=ON.
4. Begin pedaling at a constant rate at least 25 RPM. While pedaling, confirm there is pedal resistance. Stop pedaling. **IMPORTANT:** When switching from FIELD=ON to FIELD=OFF, the pedals must stop completely to allow the pedal resistance control to be reset each time.
5. Disable Field Voltage. Use the Down Arrow key to change FIELD=ON to FIELD=OFF.
6. Pedal the Cross-Trainer again at a constant rate at least 25

RPM and check that there is now no pedal resistance. Continue pedaling.

7. Enable Field Voltage again: FIELD=ON and check again that there is pedal resistance. If so, the Field Voltage line is working properly. Stop pedaling.
8. Press the Display Lock key to change the display to ALT REG. The initial value is OFF.
9. Begin pedaling at a constant rate at least 25 RPM. The pedaling must continue while the console settings are changed, checking for slight differences in pedal resistance.
10. Regulate Alternator-Voltage. Use the Up Arrow key to change ALT REG=OFF to ALT REG = ON. Check that the pedal resistance decreases slightly.
11. Set ALT REG=OFF again and check that the pedal resistance is slightly increased. If pedal resistance is greater when ALT REG=OFF and less when ALT REG=ON, the Alternator-Regulator line is working properly.

NOTE: Field and Alternator-Regulator settings apply only while in System Test mode and are cancelled upon exiting.

6 SERVICE AND TECHNICAL DATA

6.1 PREVENTIVE MAINTENANCE TIPS

The Life Fitness Cross-Trainer is backed by the engineering excellence of Life Fitness and is one of the most rugged and trouble-free pieces of exercise equipment on the market today. Commercial Life Fitness products are among the most popular equipment, regularly standing up to marathon use – 18 hours a day, 7 days a week – in health clubs, colleges and military facilities the world over. This same technology, engineering expertise, and reliability has gone into the Life Fitness Cross-Trainer.

Here are some preventive maintenance tips that will keep your Life Fitness Cross-Trainer operating at peak performance:

Locate the Life Fitness Cross-Trainer in a cool, dry place.

Clean the top surface of the pedals regularly.

Keep the display console free of fingerprints and salt build-up caused by sweat.

Use a 100% cotton cloth, lightly moistened with water and mild liquid detergent, to clean the Cross-Trainer. Other fabrics, including paper towels, may scratch the surface. Do not use ammonia or acid-based cleaners.

Long fingernails may damage or scratch the surface of the console; use the pad of the finger to press the selection buttons on the console.

Clean the housing and arms thoroughly on a regular basis.

NOTE: When cleaning the exterior of the unit, use a non-abrasive cleanser and soft cotton cloth. At no time should cleanser be applied directly to any part of the equipment. Place cleaning solution on a soft cloth and then wipe unit down.

NOTE: Do not move the unit or place hands into the unit while it is plugged into an electrical outlet.

6.2 PREVENTIVE MAINTENANCE SCHEDULE

Follow the schedule below to ensure proper operation of the product.

ITEM	WEEKLY	MONTHLY	BI-ANNUALLY	ANNUALLY
Display Console	C	I		
Console Mounting Bolts			I	
Accessory Tray	C	I		
Frame	C			I
Plastic Covers	C	I		
Power Cord	I			
Alternator Belt				I
Main Drive Belt				I

KEY: C=Clean; I=Inspect

6.3 TROUBLESHOOTING THE HEART RATE CHEST STRAP

HEART RATE READING IS ERRATIC OR ABSENT ENTIRELY

- Repeat the electrode wetting procedure (see How to Use the Optional Heart Rate Monitor Chest Strap). The electrodes must be wet to pick up and transmit accurate heart rate readings.
- Make sure the electrodes are flat against the skin.
- Wash the belt transmitter regularly with mild soap and water.
- Make sure the chest strap transmitter is within three feet (one meter) of the heart rate receiver.

- The chest strap is battery operated and will eventually stop functioning. If the chest strap transmitter battery is depleted, contact **Life Fitness Customer Support Services** at 800.351.3737 for instructions on how to have the chest strap replaced.

HEART RATE READING IS ERRATIC OR EXTREMELY HIGH (ABOVE 200)

When exercising with the optional heart rate chest strap, the user may come within range of electromagnetic signals strong enough to cause abnormally elevated heart rate readings. Possible sources of such signals include

- Television sets and/or antennas, computers, cars, high voltage power lines and motor driven exercise equipment.
- Another heart rate transmitter within three feet (one meter) may also cause abnormal heart rate readings.

6.4 HOW TO OBTAIN PRODUCT SERVICE

1. Verify the symptom and review the operating instructions and How To Solve Basic Operating Problems on the previous page. The problem may be unfamiliarity with the product and its features and workouts.
2. Locate and document the serial number of the unit, which is located on the serial number plate above the power entry area.
3. Contact the nearest Life Fitness Customer Support Services group:

Toll-free within the U.S. and Canada

Telephone: 800.351.3737

Telephone: 847.451.0036

FAX: 847.288.3702

For Product Service Internationally:

Life Fitness Europe GmbH

Telephone: (+49).089.317.751.66

FAX: (+49).089.317.751.38

Life Fitness (UK) LTD

Telephone: (+44).1353.665.507

FAX: (+44).1353.666.018

Life Fitness Benelux

Telephone: (+32).03.644.44.88

FAX: (+32).03.644.24.80

Life Fitness Italia S.R.L.

Telephone: (+39).0472.835.470

FAX: (+39).0472.833.150

Life Fitness Austria Vertriebs GmbH

Telephone: (+43).1615.7198

FAX: (+43).1615.7198.20

Life Fitness Asia Pacific Ltd

Telephone: 852.2891.6277

FAX: 852.2575.6001

Life Fitness Latin America

Telephone: (+1).847.451.0036

FAX: (+1).847.288.3702

Life Fitness Brazil

Telephone: [55] 11.7295-2217

FAX: [55] 11-7295-2218

Life Fitness Rotterdam

Telephone: 31.10.294.5011

FAX: 31.10.294.5029

7 SPECIFICATIONS

7.1 LIFE FITNESS 5500HR CROSS-TRAINER SPECIFICATIONS

Designed use: Residential
Maximum user weight: 300 pounds / 142 kilograms
Power requirements: 120 volt, 1.0 amp (U.S.). See Electrical Requirements for requirements outside the United States.

CONSOLE:

Type: Message Center with arrow keys
Displays: Elapsed time, RPM, calories burned per hour, heart rate, level, distance
Summaries: Total distance, total calories burned, total elapsed time of workout
Character size: 0.54 inches

PROGRAMS:

Workouts: Manual, Random, Hill, Cross-Train Aerobics, Cross-Train Reverse
Interactive HR: Fat Burn, Cardio
Modes: Aerobics and Reverse modes during Manual, Random, and Hill programs
Quick Start: Yes

Heart rate monitor: Polar® telemetry heart rate monitoring system

Resistance Levels: 20

Pedal speed range: 25 – 100 RPM

Drive type: Belt/alternator

Accessory Tray: Upgrade option

Color: Light granite with red and black accents

PHYSICAL DIMENSIONS:

Length: 80 inches / 203 centimeters
Width: 27 inches / 69 centimeters
Height: 66 inches / 168 centimeters
Weight: 235 pounds / 107 kilograms

SHIPPING DIMENSIONS:

Length: 80.75 inches / 205 centimeters
Width: 29.5 inches / 75 centimeters
Height: 48.5 inches / 123 centimeters
Weight: 290 pounds / 132 kilograms