

# FREE RUNNER® 5600

## OWNER'S MANUAL

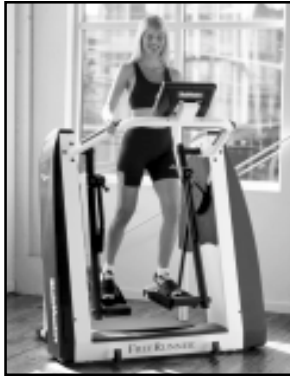

**StairMaster**<sup>®</sup>  
THE RESULTS YOU WANT™



Printed in the United States.

© 2001 StairMaster® Health & Fitness Products, Inc.  
All rights reserved.

**Corporate Headquarters**

12421 Willows Road N.E., Suite 100  
Kirkland, WA 98034

(800) 635-2936

(425) 823-1825

Fax (425) 823-9490

[www.stairmaster.com](http://www.stairmaster.com)

**StairMaster**



**P/N 22870-A**

© 2001 StairMaster Health & Fitness Products, Inc., StairMaster, and FreeRunner are registered trademarks or trademarks of StairMaster Health & Fitness Products, Inc. in the United States and/or other countries. StairMaster is a Rutledge Capital company.

## WARRANTY

This is to certify that the StairMaster® FreeRunner™5600 ESS elliptical system is warranted by StairMaster Health & Fitness Products, Inc. to be free of all defects in materials and workmanship. This warranty does not apply to any defect caused by negligence, misuse, accident, alteration, improper maintenance, or an "act of God." This warranty is nontransferable from the original owner.

If, within three years from the date of purchase, any part of the StairMaster FreeRunner elliptical system should fail to operate properly (except any accessories), contact our Customer Service Department to report the problem. When calling, please be prepared to provide the customer service representative with the following information:

- Your name, shipping address, and telephone number.
- The model and serial number of the inoperable machine.
- The date(s) of purchase for the inoperable machine(s).
- Your billing address.

This information will ensure that you are the only one ordering parts under your warranty agreement. If warranty replacement parts are shipped to you, you may be required to return the inoperable part. To facilitate this process, the following policy has been established:

- Please call our Customer Service Department to receive a Return Materials Authorization (RMA) number prior to shipment.
- StairMaster Health & Fitness Products, Inc. will incur all freight charges for warranty parts for a machine that is less than 45 days old. You will not be responsible for the return shipment of the inoperable parts.
- Some inoperable warranty parts must be promptly returned to our Customer Service Department. We will pay the shipping cost for such inoperable warranty parts. Detailed instructions are included with each warranty replacement part.

StairMaster Health & Fitness Products, Inc. neither makes, assumes, nor authorizes any representative or other person to make or assume for us any other warranty whatsoever, whether expressed or implied, in connection with the sale, service, or shipment of our products. We reserve the right to make changes and improvements in our products without incurring any obligation to similarly alter products previously purchased. In order to maintain your product warranty and to ensure the safe and efficient operation of your machine, only authorized replacement parts can be used. This warranty is void if parts other than those provided by StairMaster Health & Fitness Products, Inc. are used.

*Note: Aerosol products cannot be transported via air.*

Regular use of the StairMaster® FreeRunner® 5600 ESS is a safe and effective way to develop aerobic fitness while conditioning the major muscles of the lower body. In order to get the best results, and to keep your machine in peak operating condition, you should carefully read and follow the guidelines presented in this manual.

### **WHAT IS IN THIS MANUAL?**

The first part of this manual includes sections on safety, installation, operating instructions, and preventive maintenance. The second part contains detailed information on problem troubleshooting and repair procedures. An Appendix at the end of the manual provides important phone numbers, additional instructional illustrations, and wiring diagrams.

Throughout this manual, the console keypad keystrokes are enclosed in [ ]. The names of the keys and special console operational modes are shown in capital letters. For example, your machine is ready to use when the console displays "SELECT WORKOUT". Press the [MANUAL] key to select the MANUAL workout option.

### **WHAT IS THE STAIRMASTER FREERUNNER ELLIPTICAL STRIDING SYSTEM?**

The StairMaster FreeRunner 5600 ESS is an elliptical striding system that allows users to simulate the natural movement path of running without joint impact or trauma. With its patent pending VSL (Variable Stride Length) technology, the FreeRunner permits users to adjust their stride lengths from 10" to 40." The FreeRunner also has retractable handles to provide users with the options of lower body only or total body workouts. Another feature of the FreeRunner is Polar® heart rate monitoring.



# CONTENTS

<b>SAFETY GUIDELINES</b> .....	1
<b>INTRODUCTION</b> .....	3
<b>INSTALLATION INSTRUCTIONS</b> .....	5
<b>BASIC OPERATING PROCEDURES</b> .....	10
General Guidelines for Safe Operation .....	10
Your First Workout .....	11
<b>HEART RATE MONITORING</b> .....	14
Locked/Non-Locked Option .....	14
Error Messages .....	15
<b>TELEMETRY (POLAR®) HEART RATE</b> .....	17
Using the transmitter Belt .....	17
Maintaining the Transmitter Belt .....	18
<b>FREERUNNER 5600 ESS CONSOLE</b> .....	19
The Display Window .....	19
The Numeric Keypad .....	20
The Entertainment Keypad .....	20
The Intensity Level Keys .....	20
The Stop Key .....	20
The Workout Statistics .....	21
The Exercise Program Keypad .....	22
The Quick Start Program .....	22
The Manual Program .....	22
The Fat Burner Program .....	23
The Aerobic Training Program .....	23
The Speed Intervals Program .....	23
The Constant Heart Rate Program .....	24
The Fitness Test Program .....	25
Understanding Submaximal Exercise Testing .....	25
Pretest Screening .....	27
The StairMaster Submaximal Fit Test .....	27
Console Codes .....	31
Custom Codes .....	31

# CONTENTS

Quick Scan Programming .....	32
Machine Status Codes .....	33
Quick Scan Programming .....	34
Configuration Codes .....	34
<b>MAINTENANCE INSTRUCTIONS .....</b>	<b>35</b>
Helpful Hints .....	35
Tool List .....	35
Maintenance Records .....	35
Initial Service .....	36
Preventive Maintenance .....	36
Cleaning .....	36
Inspecting .....	36
Lubrication .....	37
<b>TROUBLESHOOTING .....</b>	<b>39</b>
General Troubleshooting Guidelines .....	39
Basic Electrical Theory .....	39
The Power Control Board .....	39
Systematic Electrical Troubleshooting .....	43
Console Diagnostic Tests .....	46
Systematic Mechanical Troubleshooting .....	51
<b>PARTS REMOVAL AND REPLACEMENT .....</b>	<b>53</b>
Alternator .....	53
Bearings .....	54
Bearing Blocks – Heel Link .....	54
Bearing Blocks – Leg Assembly .....	54
Flange Bearings – Heel Link .....	55
Flange Bearings – Leg Assembly .....	55
Belts .....	55
Upper Poly-V Belt .....	55
Lower Poly-V Belt .....	56
Brake System .....	57
Brake Actuator Arm .....	57
Brake Motor .....	57
Brake .....	58
Cables .....	59

# CONTENTS

Alternator Cable .....	59
Upper Main Cable .....	59
Lower Brake Cable .....	60
Lower Main Cable .....	60
Limit Switch Cable .....	60
Power Connector Cable .....	62
Stride Sensor Cable .....	63
Chains .....	63
Upper Heel Link Chains .....	63
Lower Heel Link Chains .....	64
Front Drive Chain Assembly .....	65
Rear Drive Chain Assembly .....	65
Step Chains .....	66
Console .....	67
Console Handlebar .....	67
Covers .....	68
Base Cover .....	68
Heel Link Pivot Cover .....	68
Safety Panel .....	68
Side Cover .....	68
Drive Shaft Assembly .....	69
Handle Assembly .....	69
Handle Knob Assembly .....	70
Heel Link .....	70
Heel Link Pivot Assembly .....	71
Leg Assembly .....	71
Load Resistor .....	72
Mounting Blocks .....	72
Pedal Assembly .....	73
Pedal Return Springs .....	74
Power Control Board .....	74
Pulleys .....	75
Idle Pulley Assembly .....	75
Intermediate Poly-V Pulley Assembly .....	75
Lower Poly-V Pulley .....	76
Rear Support Bar .....	76
Step .....	77
Stride Sensor .....	77

# CONTENTS

Spring Cartridge .....	77
Sprockets .....	78
Drive Chain Idler Sprockets and Heel Link Idler Sprockets .....	78
Drive Sprockets .....	78
Upper Heel Link Idler Sprockets .....	79
Turnbuckle Assembly Adjustment .....	80

<b>GROUNDING INSTRUCTIONS .....</b>	<b>81</b>
-------------------------------------	-----------

<b>NOTICE OF FCC COMPLIANCE .....</b>	<b>82</b>
---------------------------------------	-----------

## APPENDICES

Important Phone Numbers .....	83
Figures 18-37 .....	84

## LIST OF TABLES

Table 1: Dimensions and Specifications .....	4
Table 2: Fitness Rating Norms ( $VO_{2max}$ ) .....	22
Table 3: Recommended Preventive Maintenance Schedule .....	38

## LIST OF ILLUSTRATIONS

Figure 1: Major Parts .....	3
Figure 2: Shipping Components .....	5
Figure 3: Tywrap Location .....	6
Figure 4: Cable Locations .....	7
Figure 5: Level Adjusting End Caps .....	8
Figure 6: DC Power Connector .....	9
Figure 7: Correct Foot Placement .....	12
Figure 8: Transmitter Belt .....	16
Figure 9: The FreeRunner 5600 ESS Console .....	19
Figure 10: StairMaster Fitness Protocol .....	29
Figure 11: Alternator Mounting .....	53
Figure 12: Belt Location .....	56
Figure 13: Brake Location .....	58
Figure 14: Limit Switch Assembly .....	62
Figure 15: Upper Heel Link Chains .....	64





## CONTENTS

Figure 16: Grounding System .....	81
Figure 17: Final Assembly - Left Side .....	84
Figure 18: Final Assembly - Right Side .....	85
Figure 19: Chain Assemblies .....	86
Figure 20: Belt Tension .....	87
Figure 21: Drive Shaft Assembly .....	88
Figure 22: Leg Assembly .....	89
Figure 23: Heel Link Assembly .....	90
Figure 24: Pedal Mounting .....	91
Figure 25: Pedal Assembly .....	92
Figure 26: Master Links .....	93
Figure 27: Heel Link Pivot Adjustment .....	94
Figure 28: Handle Assembly .....	95
Figure 29: Limit Switch Assembly .....	96
Figure 30: Power Control Board "A" .....	97
Figure 31: LED Panel .....	98
Figure 32: Power Control Board "B" .....	99
Figure 33: Alternator Cable .....	101
Figure 34: Power Supply .....	102
Figure 35: Load Resistor .....	103

WHEN USING ELECTRICAL EQUIPMENT, ALWAYS FOLLOW THESE BASIC PRECAUTIONS:

## IMPORTANT SAFETY INSTRUCTIONS



This symbol appearing throughout this manual means Attention! Be Alert! Your safety is involved.

The following definitions apply to the words “Danger” and “Warning” found throughout this manual:

**DANGER** – Used to call attention to IMMEDIATE hazards which, if not avoided, will result in immediate, serious personal injury or loss of life.

**WARNING** – Used to call attention to POTENTIAL hazards that could result in personal injury or loss of life.

**READ ALL INSTRUCTIONS BEFORE USING THE MACHINE.**



### **DANGER**

To reduce the risk of electrical shock, always unplug the external power supply from the AC wall outlet before cleaning, maintaining, or repairing.



### **WARNING**

To reduce the risk of burns, fire, electric shock, or injury to persons:

1. Close supervision is necessary whenever the machine is used by or near children, invalids, or disabled persons.
2. Do not operate or remove the back cover while the machine is plugged into a power source. Keep your hands away from all moving parts.



## SAFETY GUIDELINES

3. Use this machine only for its intended use as described in this manual. Do not use parts, attachments, or accessories other than those provided by StairMaster® Health & Fitness Products, Inc.
4. Connect the power supply cord to a properly grounded AC wall outlet; refer to the “Grounding Instructions” section. Keep all cords away from heated surfaces.
5. To disconnect, remove the plug from the outlet.
6. Never drop or insert any object into any opening on the machine.
7. Do not operate where aerosol (spray) products are being used or where oxygen is being administered.
8. Do not use the machine outdoors.
9. Never operate this equipment if it has a damaged cord or plug, if it is not working properly, if it has been dropped or damaged, or dropped in water. Contact our Customer Service Department at 1-800-331-3578 for help.
10. This equipment is intended for commercial use.

The design of this equipment provides a safety level that can only be maintained when the equipment is regularly examined for damage and wear. Inoperable components should be replaced immediately and the equipment should be taken out of service until it is repaired.

Failure to follow all guidelines may compromise the effectiveness of the exercise experience, expose anyone on or close to the machine to injury, and reduce the longevity of the machine. Follow all training instructions listed in the manual and/or on the machine. Physical injury may result from incorrect or excessive training.

**SAVE THESE INSTRUCTIONS**

# INTRODUCTION

Before leaving the manufacturing facility in Tulsa, Oklahoma, your StairMaster® FreeRunner® Elliptical Striding System was thoroughly inspected and tested to ensure proper operation. The major parts of the machine are shown in Figure 1.

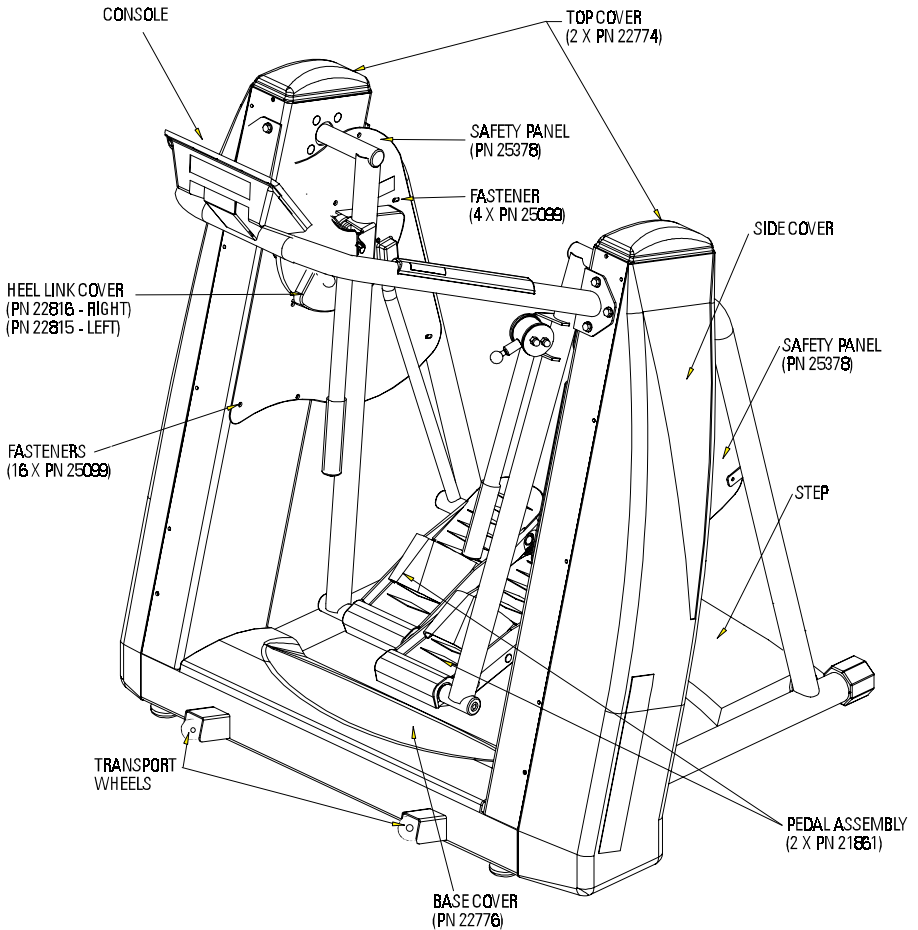

Figure 1: Major Parts

## INTRODUCTION

Throughout this Manual, all references to the left or right side and to the front or back are made as if you were on the machine, ready to exercise. For example, the console is located on the front of the machine. The dimensions and general specifications of the machine are listed in Table 1.

**Table 1. Dimensions and Specifications for the StairMaster® FreeRunner® Elliptical Striding System**

### Physical Dimensions:

Height	64.0" (163 cm)
Depth	
at base	40.0" (102 cm)
w/Console & Back Platform	48.0" (122 cm)
Width	52.0" (132 cm)
Weight	485.0 lbs (220 kg)

### Range of Motion:

Maximum stride length	54"
Peak elliptical pattern	12" - 36"

### Power Supply Specifications\*:

Input Voltage	110-120 VAC, 50/60 Hz
Output Current Capacity	2.5 Amps
Input Power Consumption	55 Watts

\*Optional power supplies, intended for use outside the United States, are available for 220-240 VAC, 50/60 Hz power requirements.

# INSTALLATION INSTRUCTIONS

Your FreeRunner® is shipped complete with all parts required for assembly. Study the assembly instructions carefully. The shipping components are shown below in Figure 2. Contact our Customer Service Department at (800) 331-3578 for assistance. International customers should contact their local distributors.

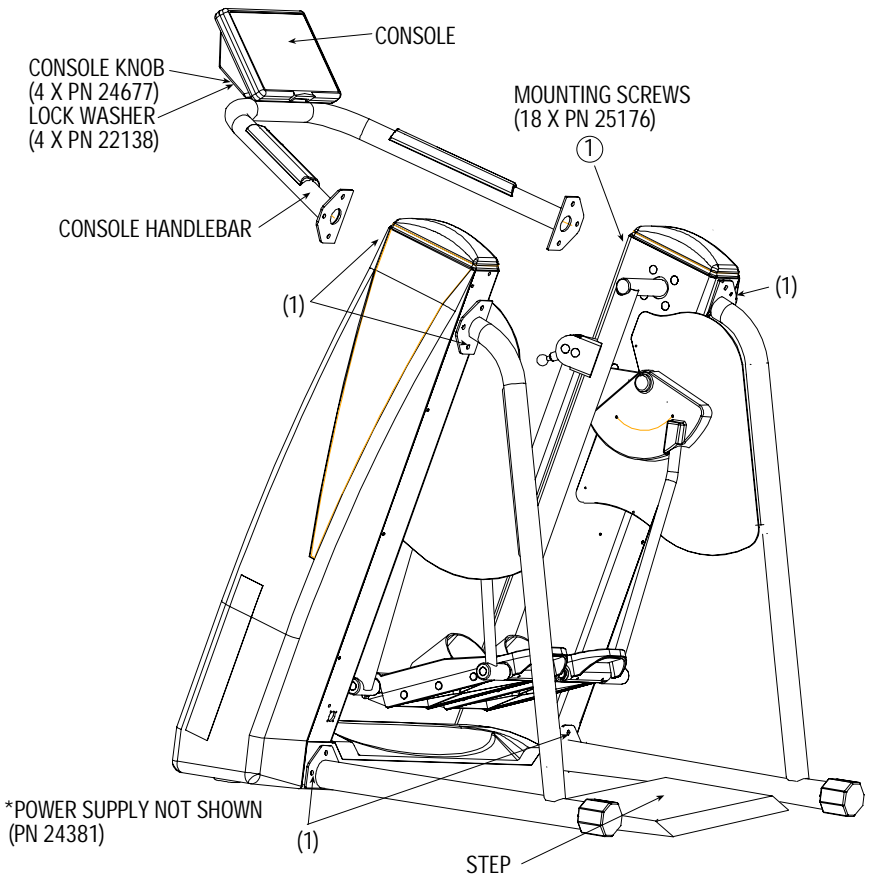
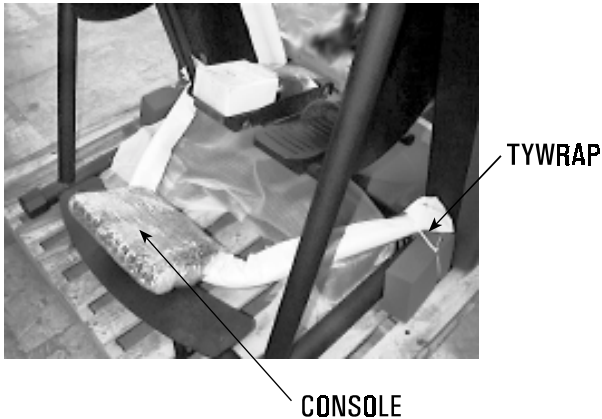

**Figure 2: Shipping Components**

# INSTALLATION INSTRUCTIONS

## A. Assemble the Machine:

1. Cut each tywrap that secures the console handlebar to the rear support bars (see Figure 3). Remove the foam protection from each side of the handlebar. Lift the handlebar out from under the pedals. Set the handlebar with console aside. Remove the step from under the pedals and set the step aside.



**Figure 3: Tywrap Location**

2. Remove the shrink wrap from the pedal, and lift the power supply box, owner's manual, and hardware bag off the pedal. Set the parts aside.
3. Remove the top covers. Use the fastener removal tool from the hardware bag to remove the top cover rivets. Disconnect the Polar® heart rate receiver under the right top cover from the upper Polar heart rate cable (see Figure 4).
4. Have an assistant support the console handlebar. Stand on the right side of the machine and connect the lower Polar heart rate cable from the handlebar to the upper Polar heart rate cable in the frame. Connect the upper Polar heart rate cable to the heart rate receiver and reinstall the top cover.
5. Stand on the left side of the machine and connect the upper main cable coming out from the handlebar to the lower main cable from the frame. Next, connect the upper brake cable from the handlebar to the

# INSTALLATION INSTRUCTIONS

lower brake cable from the frame. Tuck any excess slack in the cables up inside the handlebar.

6. Attach the console handlebar to the frame. To prevent the rivnuts (see Figure 4) from spinning in the frame, hold the rivnuts with pliers while securing the mounting screws to the frame.

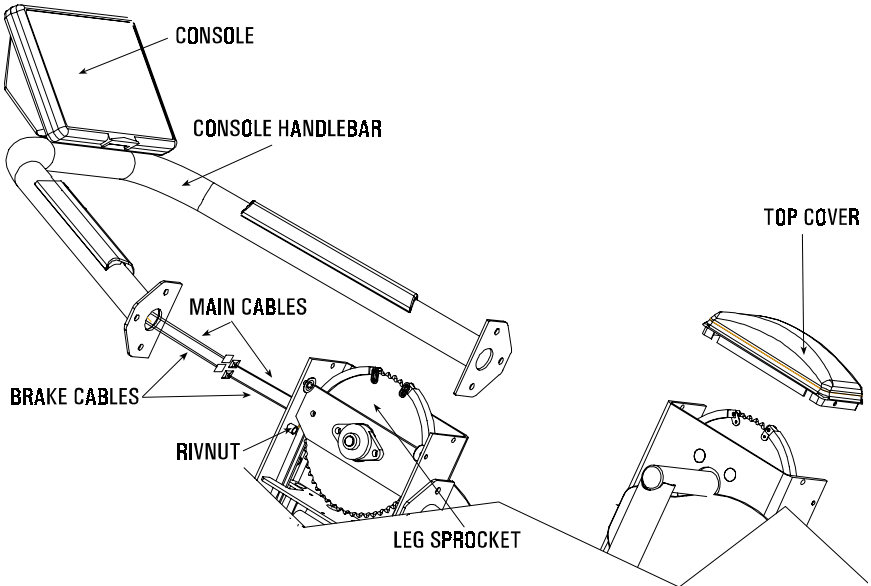

**\*NOTE: KEEP EXCESS SLACK IN CABLES AWAY FROM THE LEG SPROCKETS.**

**Figure 4: Cable Locations**

7. Have an assistant help you slide the machine off the shipping pallet and onto the floor. Use the transport wheels (see Figure 1) to roll the machine into the desired location.
8. Remove the packing material from the console, handlebar, and step. Place the step inside the rear supports and insert a mounting screw and a washer into each step hole. Tighten each screw.



# INSTALLATION INSTRUCTIONS

## B. Level the Machine:

1. Make sure the machine is level before you use it for the first time. The rubber end caps (see Figure 5) are designed to compensate for uneven floors. Each face of the caps is a different thickness. Twist the caps to stabilize the machine.

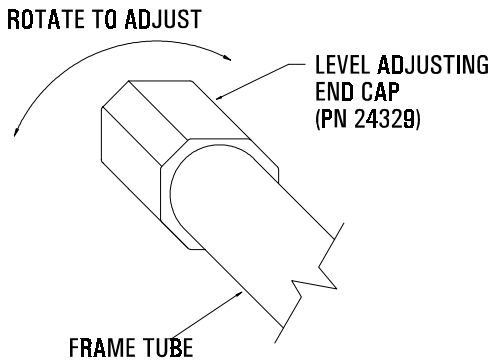

**Figure 5: Level Adjusting End Caps**

## C. Connect the Power Supply:

1. Remove the external power supply from the shipping box. Connect the DC power cable to the DC power connector located on the lower left side (see Figure 6).

### **WARNING**

TO REDUCE THE RISK OF ELECTRICAL SHOCK AND FIRE AND TO PREVENT SEVERE DAMAGE TO THE MACHINE, USE ONLY THE POWER SUPPLY APPROVED FOR USE WITH THIS EQUIPMENT. IN ADDITION, YOUR MACHINE MUST BE PROPERLY GROUNDED.

2. Place the power supply on the floor near an AC wall outlet. To reduce the hazard of electrical shock, place the power supply in a location away from the machine and away from exposure to perspiration. You should not place your power supply on carpet because it may overheat.

## INSTALLATION INSTRUCTIONS

3. Check to be sure that the input AC power rating marked on the power supply matches the available power. If it does not, obtain the matching power supply from StairMaster® Health & Fitness Products, Inc. before proceeding any further.

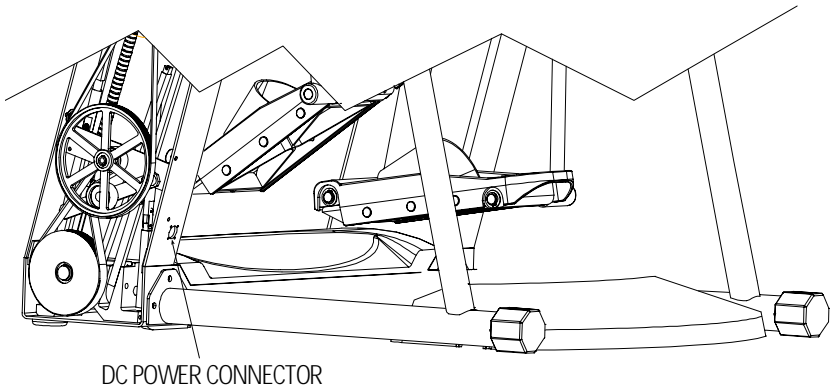

**Figure 6: DC Power Connector**

4. Connect the AC power cord to the AC wall outlet. Refer to the "Grounding Instructions" section if the AC wall outlet does not accept a three-prong plug.
5. Watch the console. The console should display a software revision code and then show "SELECT WORKOUT." If it does not, unplug the power supply, then plug it back in. If the console still does not power up correctly, contact our Customer Service Department. Refer to the Appendix for the appropriate telephone number.
6. The console ready to use when the display "SELECT WORKOUT" is shown.

# BASIC OPERATING PROCEDURES

## GENERAL GUIDELINES FOR SAFE OPERATION



THESE GUIDELINES ARE DIRECTED TO YOU, AS THE OWNER OF THE MACHINE. YOU SHOULD INSIST THAT ALL USERS FOLLOW THE SAME GUIDELINES. YOU SHOULD MAKE THIS MANUAL AVAILABLE TO ALL USERS.

1. Obtain a complete physical examination from your medical doctor, and enlist a health/fitness professional's aid in developing an exercise program suitable for your current health and fitness status.
2. When working out for the first time, use the MANUAL exercise program at a low intensity level until you feel comfortable and capable of higher resistance levels.
3. The intensity and duration of your exercise program should always be subject to how you feel. Never permit peer pressure to influence your personal judgment while exercising.
4. Overweight or severely deconditioned individuals should be particularly cautious when using the machine for the first time. Even though such individuals may not have a history of serious physical problems, they may perceive the exercise to be far less intense than it really is, resulting in the possibility of overexertion or injury.
5. Although all equipment manufactured by StairMaster® Health & Fitness Products, Inc. has been thoroughly inspected by the manufacturing facility prior to shipment, proper installation and regular maintenance are required to ensure safety. Maintenance is the sole responsibility of the owner.

# BASIC OPERATING PROCEDURES

## YOUR FIRST WORKOUT ON THE STAIRMASTER® FREERUNNER® ELLIPTICAL STRIDING SYSTEM

### Basic Instructions for First-Time Users

1. Warm up with light calisthenics and easy stretching exercises for at least five minutes before beginning your exercise program.

### **WARNING**

IF AT ANY TIME DURING YOUR WORKOUT YOU FEEL CHEST PAIN, EXPERIENCE SEVERE MUSCULAR DISCOMFORT, FEEL FAINT, OR SHORTNESS OF BREATH, STOP EXERCISING IMMEDIATELY. IF THE CONDITION PERSISTS, YOU SHOULD CONSULT YOUR MEDICAL DOCTOR IMMEDIATELY.

2. Stand on the step, and then step forward onto the pedals (see Figure 7). Notice that the pedals are braked in position. Pressing a workout key will disengage the brake. The brake can also be disengaged by pushing the pedals apart forcibly. However, this is not recommended as it will cause premature wear on the brake assembly.
3. To raise or lower the retractable handles, pull the handle adjustment knob out on each handle to move the handle (see Figure below). Ensure that each knob is locked into place before beginning your workout.

**Note:** Always hold onto the handles when they are in the upright position.

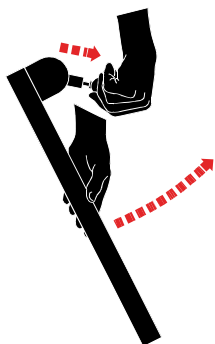

**Pull the pin out to unlock the handle**

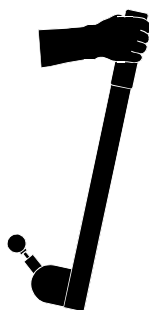

**Swing the handle upwards and release the pin to lock the handle in position**

## BASIC OPERATING PROCEDURES

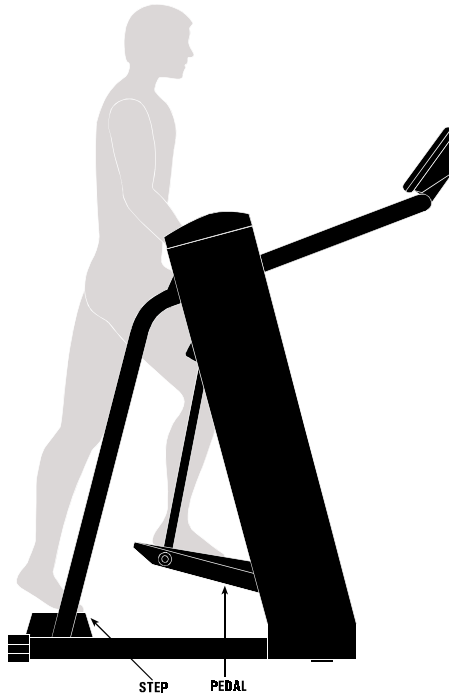

**Figure 7: Correct Foot Placement for Stepping onto the FreeRunner® Pedals**

4. Select the MANUAL exercise program so that you can control the pace of your first workout and get accustomed to the exercise motion. Press [MANUAL] and then press [ENTER]. The console will return to the start screen if you do not press [ENTER] within 60 seconds.
5. The console will prompt you to enter your body weight. Enter your weight in pounds (or kilograms if the console is set to metric). Correct entry errors by pressing [CLEAR] before you press [ENTER].
6. The console will prompt you to enter the workout time in one-minute increments between 5 and 99 minutes. Press [1], [0], [ENTER] to exercise for ten minutes. If you do not start exercising within 60 seconds, the console will return to the start screen.

# BASIC OPERATING PROCEDURES

## Begin Exercising

7. Lean forward and take running strides without overextending your legs. The MANUAL program starts at intensity level 3. Adjust the intensity level up or down as desired.
8. Relax and stand up straight while exercising. Use the handles for balance. If you do not have the handles engaged, use the console handlebar for balance.
9. Select an intensity level that allows you to maintain a comfortable stride. Faster is not always better. Exercise at a level that is consistent with your fitness level.

## Rest Periods

10. You can stop and rest as many times as necessary for up to one minute for each rest period during all programs. To stop, either press [STOP] or step off the machine. The console returns to the start screen if you rest longer than the allotted rest period. Follow the onscreen prompt to continue your work out after a rest period.

## Cool Down

11. When you are finished with your workout, the machine will slow down and the message "GOAL ATTAINED" will be displayed. You can cool down on the machine by continuing to step. The console timer will continue to count up from the selected time to the maximum time, and the intensity level will default to level 3. For example, if the time limit was set for 30 minutes and you worked out for 25 minutes, the cool down period would last for 5 minutes, or until you stepped off the machine. If no time limit is set, the console will count up to 99, return to 0, and start counting up again. Press [STOP] to end the cool down.
12. You can also cool down by getting off the machine walking or stretching for at least five minutes.



# HEART RATE MONITORING

## HEART RATE INPUT

The FreeRunner® 5600 console features telemetry (e.g., Polar®) heart rate signal detection. There is a short “lock out” period at the beginning of each workout session during which the console first detects a signal and then validates the signal type. The lock out period is as follows:

- Telemetry heart rate - after the initial belt signal is detected, the console will enter a validation phase in which four good heart beat signals within four seconds are required before locking on telemetry heart rate signals for the duration of the workout session. During the validation phase the console will not recognize contact heart rate signals.

## LOCKED/NON-LOCKED OPTION

When the “not locked” option is selected the heart rate source signal (telemetry or contact (not available on the 5600)) is not fixed during the exercise. If the “locked” option is selected then the heart rate source signal is locked on the first detected signal during the workout. To set a heart rate signal input, or to turn off the heart rate option all together, perform the following steps:

1. On the console keypad, press [LEVEL: ^], [3], [2]. At this point the screen will display “HR INPUTS.” Press [ENTER] to select this option.
2. There are four options to handle heart rate input signals. Press the [SELECT] key to scroll through the options until you find the one option that suites your needs. Press the [ENTER] key to select that option.

“ **BOTH HR ON** ” - allows either telemetry or contact heart rate signals to be detected. Once the console has detected a valid input signal it will lock out the opposite type of signal for the duration of the workout session. For example, if you start out using contact heart rate then you are limited to using only contact heart rate during your workout session, even if the signal is lost while performing the workout, and vice-versa.

## HEART RATE MONITORING

**" BOTH NOT LOCKED "** - allows either telemetry or contact heart rate signals to be detected. Does not lock out a particular input signal for the entire workout. This option will detect either input signal during a workout session, but only one at a time, and only until the other signal terminates.

**" TELEMETRY ONLY "** - locks out contact heart rate signals and will only detect telemetry signals. ***Your console should be set to this option.***

**" HAND ONLY "** - locks out telemetry signals and will only detect contact heart rate signals. Do not use this option on this machine.

**" BOTH HR OFF "** - turns off the ability to detect any signal at all. Used in rare situations where there is excessive interference with the heart rate signals. This option disables the Constant HR program and the Fitness Test program.

### Error Messages

Text line messages are only seen in the Constant Heart Rate and Fitness Test programs due to the design of the program that necessitates a valid heart rate signal at all times during the program. For these programs, ensure that neither the "BOTH HR OFF" or the "HAND ONLY" option is set as a default option.

**"CHECK HR BELT "** - The heart rate signal has been missing for the last 30 seconds in telemetry signal detection.

**"HR BELT NEEDED"** - No telemetry belt signal been sensed during the initial setup time.

**"HOLD HR SENSORS"** - In contact heart rate signal situations this message will come every 30 seconds to prompt the user to hold the sensors.

**"HR MODE DISABLED"** - No heart rate signal is allowed due to the set up option that was chosen. Heart rate monitoring is not possible.



# TELEMETRY HEART RATE

## TELEMETRY HEART RATE

The StairMaster® FreeRunner® 5600 features telemetry (Polar®) heart rate monitoring. The system consists of the receiver, located in the console and a transmitter belt (purchased separately) worn across your chest. The monitoring function is activated as soon as you strap on the chest belt and step within range of the receiver in the machine. Two electrodes on the underside of the chest belt sense the heart rate signal and send it to the receiver. The heart symbol on the console pulses to indicate that the console is receiving a valid signal. A microprocessor in the console calculates the heart rate and displays it, in beats per minute, on the console.

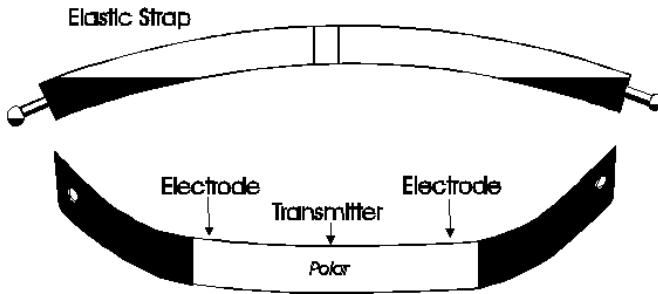

Figure 8: Transmitter Belt

### Using the Transmitter Belt



#### WARNING

PACEMAKER USERS SHOULD NOT USE THE POLAR TRANSMITTER BEFORE CONSULTING THEIR DOCTOR.

Before you put the transmitter belt on, wet the two electrode patches (the grooved rectangles on the reverse side of the belt). Secure the transmitter belt as high under the pectoral muscles (chest) as is comfortable.

## TELEMETRY HEART RATE

The transmitter belt should fit snugly and comfortably, and allow normal breathing. When the console detects a heart rate signal, heart rate is shown in the display automatically. Your heart rate in beats per minute and a pulsing heart icon are displayed

After the initial belt signal is detected, the console will enter a validation phase in which four good heart beat signals lasting four seconds are required before locking on telemetry heart rate signals for the duration of the workout session. During the validation phase the console will not recognize contact heart rate signals. If you do not see a heart rate on the console, try one of the following:

- Move closer to the console.
- Tighten the elastic part of the chest belt.
- Adjust the belt higher or lower on your chest.
- Remoisten the electrodes.
- Test your chest strap with a machine that you know is working, or with a heart rate watch that you know is working.
- If possible, replace or exchange your console with a console (from the same type of machine) that you know is working and retest the machine.

### Maintaining the Transmitter Belt

Clean the chest belt regularly with mild soap and water, then dry thoroughly — residual sweat and moisture keep the transmitter active and drain the battery in the transmitter. Do not use abrasives or chemicals such as steel wool or alcohol for cleaning, as they can damage the electrodes permanently. You can order replacement belts from StairMaster, Polar Electro, Inc., or your local fitness store:

StairMaster	800-331-3578	P/N 64000
Polar Electro, Inc.	800-227-1314	

# FREERUNNER 5600 ESS CONSOLE

The StairMaster® FreeRunner 5600 ESS systems console is divided into seven sections: the display window, the workout options, the numeric keypad, the entertainment keypad, the workout statistics, the stop key, and the intensity level keys (see Figure 9).

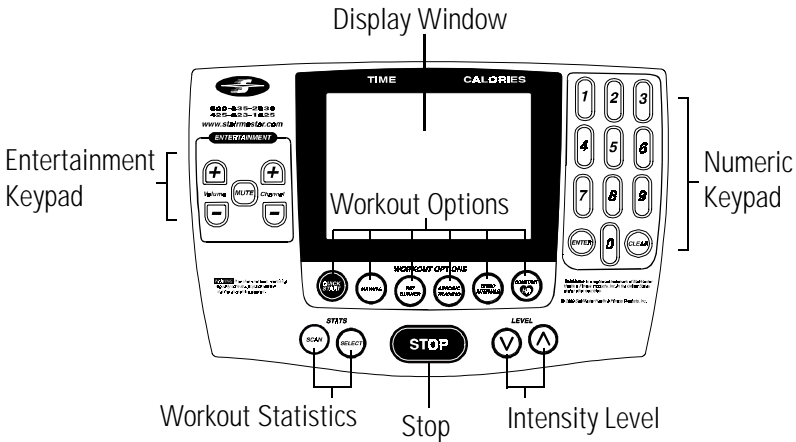

Figure 9: The FreeRunner 5600 ESS Console

## THE DISPLAY WINDOW



- **Time** - The selected workout time is displayed in the upper left section of the display window. Once the time is entered, the timer will count down, in minutes and seconds, until the workout is finished or stopped. If [0] is entered in the MANUAL or CONSTANT HEART RATE program, the timer will count up.
- **Calories** - The real-time amount of calories burned is continually updated and displayed in the upper right section of the display window.
- **Interval Timer** - The interval timer is displayed below the Time. The interval timer counts down time left within each interval.
- **Heart Rate** - Current heart rate is displayed below the Calories, next to the heart icon.
- **Workout Option Profile** - A profile of the selected exercise program appears in the lower section of the display window during a workout. The taller the column, the higher the intensity (watts) for that interval. The flashing column shows your current interval. The flashing column moves from left to right across the display as you complete each interval.

# FREERUNNER 5600 ESS CONSOLE

## THE NUMERIC KEYPAD

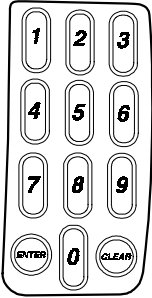

The numeric keypad is located on the right side of the console. Before the exercise program begins, the numbers are used to enter data in response to the console prompts.

- **Enter** - Confirms workout selections and stores the information used by the console to calculate workout statistics.
- **Clear** - Erases information from the console memory if pressed before [ENTER].

## THE ENTERTAINMENT KEYPAD

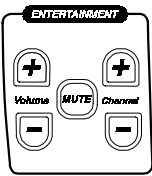

The FreeRunner comes equipped to facilitate the use of commercial entertainment systems. Using any of these keys will send an output signal through the Communication Specification for Fitness Equipment (C.S.A.F.E.) port to a connected C.S.A.F.E. or compatible system. If a system is not connected, pressing these keys will have no effect.

- **Volume Up/Down** - Increases or decreases the volume level of the audio source.
- **Mute** - Removes the audio sound from the headphones.
- **Channel Up/Down** - Changes the channel of the commercial entertainment system.

## THE INTENSITY LEVEL KEYS



The exercise intensity level may be changed at any time during a workout. Pressing the [DOWN ARROW] key decreases the intensity and pressing the [UP ARROW] key increases the intensity.

## THE STOP KEY



Press the [STOP] key any time you want to pause the exercise program for up to one minute. Press [STOP] a second time, or [1], and The console will return to the "SELECT WORKOUT" prompt.

# FREERUNNER 5600 ESS CONSOLE

## WORKOUT STATISTICS

During the exercise program, the Stats keys are used to track workout statistics which are then shown in the display window. Pressing the [SELECT] key turns off the scanning feature and shows the statistic of choice in the display window. Pressing the [SCAN] key will prompt the console to cycle through the following statistics:

- **Distance** - Provides a cumulative total of the equivalent distance, in miles (or kilometers if your console is set to metric units), you would have traveled while riding a bicycle outdoors at the same relative intensity.
- **Calories/Hour** - Provides a calorie rate of energy usage.
- **Length** - Displays the stride length in inches.
- **Speed** - Displays the equivalent running speed, in miles per hour (or kilometers per hour if your console is set to metric units), based on energy expenditure.
- **Level** - Shows the current intensity level between 1 (the easiest) and 20 (the hardest).
- **Watts** - Displays the exercise intensity in watts (746 watts = 1 horsepower).
- **METS** - Gives you the relative energy cost of exercise. MET stands for multiples of the resting metabolic rate. While you are sitting quietly, your body consumes oxygen at the rate of about 3.5 milliliters per kilogram of body mass per minute. When you exercise, your body needs more oxygen in order to function. For example, exercising at 10 METs requires ten times the resting rate of oxygen consumption, or about 35 milliliters per kilogram per minute. During a workout, this key shows the current MET level. During the workout summary, the average MET level is displayed.
- **Target Heart Rate** - Available only during the Constant Heart Rate program. Shows the selected target heart rate.

At the completion of a workout, the statistic averages are calculated based on the accumulation of data during the workout program, and not including the cool down period.

# FREERUNNER 5600 ESS CONSOLE

## EXERCISE PROGRAM KEYPAD

The exercise keypad is located below the display and to the left of the function keypad. While the console is in the "SELECT WORKOUT" mode, press one of the exercise program keys to preview the desired workout. There are six workout programs with the following standard defaults (these values are used in every workout session where user data is not provided):

- **Weight** - 175 lbs.
- **Intensity Level** - 3
- **Workout Time** - The default time in the programmed workouts and Quick Start is 20 minutes. The Manual and Constant Heart Rate programs do not have a specified default time. In these programs, the console timer will count up to the maximum time of 99 minutes, and then return to 0.
- **Age** (Constant Heart Rate program only) - 40 years

Once you have selected a program, the prompts are:

- "**ENTER BODY WEIGHT**" -- type in your body weight in pounds (or kilograms if your console is set to metric units).
- "**ENTER LEVEL 1 - 20**" -- select your intensity level with level 1 being the easiest and level 20 the hardest.
- "**ENTER TIME 5 - 99**" -- select the workout duration in one minute increments from five to 99. Press 0 in the MANUAL and CONSTANT HEART RATE program to workout for an unspecified amount of time.

### The Quick Start Program

Provides an immediate start, without having to enter any user information. This program uses the standard default settings for derivation of calories burned.

### The Manual Program

After pressing the MANUAL key, enter user and workout information. Begin exercising at the selected level. If desired, adjust the workout manually by using the intensity level arrow keys. The profile in the display window is divided up into 15 equal intervals within the workout time. The profile is based

# FREERUNNER 5600 ESS CONSOLE

on the selected intensity level, with 2 levels equating to one vertical bar.

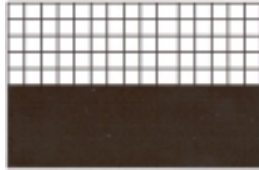

## The Fat Burner Program

The Fat Burner program is a 60 interval workout designed for people just starting a weight control program. The relative intensity level is indicated on the profile and any changes in the intensity level will continue for the remaining program



## The Aerobic Training Program

The Aerobic Training program is a 60 interval workout designed to increase aerobic capacity. The relative intensity level is indicated on the profile and any changes in the intensity level will not change the look of the program profile.



## The Speed Intervals Program

The Speed Intervals program is a workout with 8-rest intervals and 7-exercise intervals that alternate speed/intensity level changes. You can change the REST interval speed/level and the EXERCISE interval speed/level independently, using the level keys. For example, if you decrease the intensity level during a rest interval then subsequent rest intervals will be the same. However, the EXERCISE interval remains at the same intensity level you started with. To change the intensity level of the EXERCISE interval, you must change the intensity level

## FREERUNNER 5600 ESS CONSOLE

during an EXERCISE interval. The intensity level shown during an EXERCISE interval is indicative of your current speed. However, the current speed during a REST interval is equal to a scaled percentage of the displayed intensity level. Note that the program profile does not change at any time during the workout session.

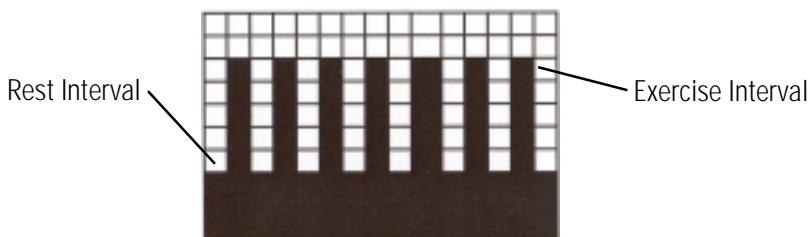

### The Constant Heart Rate Program

The Constant Heart Rate program maintains a chosen target heart rate by automatically varying the climbing speed during each workout. The default target heart rate is equal to 70% of your maximum heart rate which is calculated by the following equation:  $220 - (\text{Age}) \times .70$ . Choose a different target heart rate (between 80 and 180 beats per minute) at any time during the workout by using the numeric keypad to enter the new target heart rate, followed by the [ENTER] key. The following messages may be shown during a workout:

- **“CHECK HR BELT”** - The heart rate signal has been missing for the last 30 seconds in telemetry signal detection.
- **“HR BELT NEEDED”** - No telemetry belt signal has been sensed during the initial setup time.
- **“HOLD HR SENSORS”** - In contact heart rate signal situations this message will come every 30 seconds to prompt the user to hold the sensors. Contact heart is not available on the 5600 ESS.
- **“HR MODE DISABLED”** - No heart rate signal is allowed due to the set up option that was chosen. Heart rate monitoring is not possible.

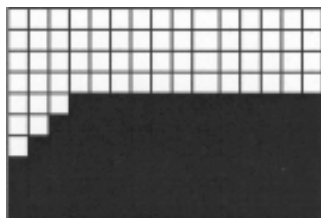



# FREERUNNER 5600 ESS CONSOLE

## The Fitness Test Programs

### Understanding Submaximal Exercise Testing

Before using the StairMaster FreeClimber for submaximal exercise testing, it should be noted that all submaximal fitness tests make several assumptions:

- That a steady-state heart rate is obtained for each exercise workload.
- That a linear relationship exists between heart rate, oxygen up take and workload.
- That the maximal heart rate for a given age is uniform.
- That the mechanical efficiency of the physical activity performed (i.e., oxygen uptake at a given workload) is the same for every one.

It should be kept in mind that any one or all of the above mentioned assumptions may not be met during a submaximal exercise test. If for any reason one of the assumptions is not met, then errors in predicting  $VO_{2max}$  will occur.

Unfortunately, it is often quite difficult to meet all of the requirements for the four listed assumptions. For example, exercising at a given workload for only a few minutes can involve an insufficient amount of time for many individuals to achieve a true steady-state. To ensure that a steady-state has been achieved, the heart rate should be measured after two minutes of exercise at a given workload and again after the third minute of exercise at that workload. These two heart rates should then be compared. If a difference of more than five beats per minute between the two is found, the subject should continue to exercise at one-minute intervals at the same workload until two successive heart rates differ by less than five beats per minute.

It is also important that the submaximal heart rates obtained be between 115 and 150 beats per minute, because it is within this heart rate range that a linear relationship tends to exist between heart rate and oxygen uptake or workload for most adults. When the heart rate is less than 115, many external factors (e.g., talking, laughing, apprehension, etc.) can greatly influence heart rate. Once the heart rate reaches a level between 115 and 150, external factors

## FREERUNNER 5600 ESS CONSOLE

no longer influence heart rate, and a linear relationship exists. As the heart rate rises above 150, the heart rate-oxygen uptake relationship becomes curvilinear.

The third assumption involves maximal heart rate. Maximal heart rate is the greatest heart rate that can be measured when an individual is exercising to the point of volitional fatigue (i.e., exhaustion) during a graded exercise test. Several equations have been developed to estimate the average maximal heart rate for humans:

- Maximal heart rate = 220 minus age (low estimate)
- Maximal heart rate = 210 minus [0.5 x age] (high estimate)
- Maximal heart rate = 226 minus age (estimate for older individuals)

Maximal heart rate can, however, vary greatly among different individuals of the same age. One standard deviation is + 12 bpm, which means that two-thirds of the population varies an average of plus or minus 12 heart beats from the average given by a prediction equation. If an individual's age-predicted maximal heart rate is higher than that person's true maximal heart rate, then his/her estimated  $VO_{2\max}$  will be an overestimation of the correct or actual value.

The final assumption addresses the issue of mechanical efficiency. Because oxygen uptake at any given work rate can vary by approximately 15% between different individuals, individuals vary in the amount of oxygen they require to perform a certain exercise workload. Some individuals are more efficient at performing a given task than others. As a result, the average oxygen consumption associated with a given workload may vary significantly from one person to another. Thus,  $VO_{2\max}$  predicted by submaximal exercise tests tends to be overestimated for those who are mechanically efficient and underestimated for those who are inefficient.

The point to remember is that submaximal exercise testing, though not as precise as maximal exercise testing, is not without advantages. For example, the results of such testing can provide a fairly accurate reflection of an individual's fitness status without the cost, risk, effort (on the part of the subject) and time involved in max testing. If an individual is given repeated

## FREERUNNER 5600 ESS CONSOLE

submaximal exercise tests and that person's heart rate response to a fixed workload is found to decrease over time, it is reasonably safe to conclude that the individual has made improvements in aerobic (cardiorespiratory) fitness, irrespective of the accuracy of the  $VO_{2\max}$  prediction.

### Pretest Screening

Prior to any exercise test (maximal or submaximal), participants should complete a brief health/medical questionnaire, have their resting blood pressure and heart rate measured, and provide an informed consent form.

The Physical Activity Readiness Questionnaire (PAR-Q) is an example of a valid health/medical questionnaire for screening individuals prior to submaximal exercise testing. Canadian health and fitness practitioners have extensively (and quite successfully) used the PAR-Q to determine whether individuals should be given an exercise test. A "yes" answer to any of the seven questions on the PAR-Q would disqualify a participant from taking part in an exercise test until appropriate medical clearance was obtained.

#### PHYSICAL ACTIVITY READINESS QUESTIONNAIRE (PAR-Q)

1. Has your doctor ever said you have a heart condition and recommended only medically supervised physical activity?
2. Do you have chest pain brought on by physical activity?
3. Have you developed chest pain within the past month?
4. Do you tend to lose consciousness or fall over as a result of dizziness?
5. Do you have a bone or joint problem that could be aggravated by the proposed physical activity?
6. Has a doctor ever recommended medication for your blood pressure or a heart condition?
7. Are you aware, through your own experience or a doctor's advice, of any other physical reason against your exercising without medical supervision?

### The StairMaster Submaximal Fit Test

The StairMaster branching protocol is a series of 3-minute stages of continuous exercise at increasing intensity. The first stage is a warm-up at approximately 4 METs. The intensity of the remaining stages is based on the heart rate response to the warm-up. The test is designed to raise the steady

## FREERUNNER 5600 ESS CONSOLE

state heart rate of the subject to 110 to 150 beats/min for two consecutive stages. It is important to remember that two consecutive heart rate measurements must be obtained in the 110 to 150 beats/min range to predict  $VO_{2max}$ . The test typically lasts from 9 to 15 minutes.

In the StairMaster protocol, each work rate is performed for 3 minutes, with heart rates recorded during the final 4 seconds of the second and third minutes of each stage. If the heart rates are within 5 beats/min, then the heart rate during the last minute is plotted against the work rate, and the program advances to the next 3-minute stage. The program continues for two to four stages until two steady state heart rates between 110 to 150 beats/min are obtained in two consecutive stages. The line generated from the plotted points is then extended to the age-predicted maximal heart rate. A corresponding maximal work rate and  $VO_{2max}$  can then be calculated.

At the end of the 3<sup>rd</sup> minute of each stage, if the heart rates at the end of the 2<sup>nd</sup> and 3<sup>rd</sup> minute are not within 5 beats/min of each other, then that work rate is maintained for an additional minute. At the end of the 4<sup>th</sup> minute, the heart rate is compared to the heart rate at the end of the 3<sup>rd</sup> minute. If the heart rates are within 5 beats/min, then the heart rate during the 4<sup>th</sup> minute is plotted against the work rate. If the heart rate at the end of the 3<sup>rd</sup> and 4<sup>th</sup> minute are not within 5 beats/min, then the work rate is maintained for one more additional minute. If the heart rate at the end of the 4<sup>th</sup> and 5<sup>th</sup> minutes are within 5 beats/min, then the heart rate at the end of the 5<sup>th</sup> minute is plotted against the work rate. If the heart rate at the end of the 4<sup>th</sup> and 5<sup>th</sup> minutes are not within 5 beats/min, then the test failed.

Once two consecutive heart rate measurements are obtained in the 110 to 150 beats/min range, then the test ends successfully and the results are displayed. Estimate maximum aerobic capacity is shown in ml/kg/min and METs. Next, the results are compared to normative values for others of the same age range and gender (see Table 2). Results are stored in the console until the next person starts an exercise program. Press [STATS SCAN] to review the results in addition to being displayed at the end of the test.

# FREERUNNER 5600 ESS CONSOLE

Figure 10: StairMaster® Fitness Protocol

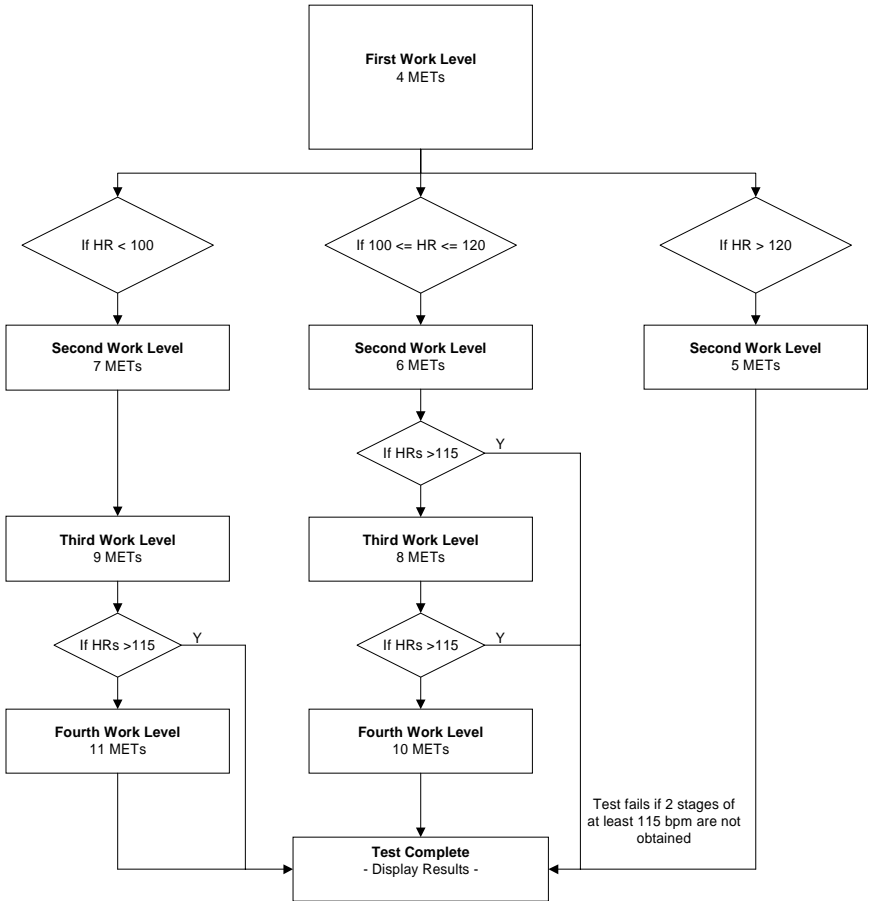

# FREERUNNER 5600 ESS CONSOLE

Table 2. Fitness Rating Norms ( $VO_{2max}$ )

<b><u>MEN</u></b>					
<b>Age</b>	<b>High</b>	<b>Good</b>	<b>Average</b>	<b>Fair</b>	<b>Low</b>
20 – 29	>51	51 – 47	47 – 43	42 – 40	<39
30 – 39	>50	50 – 45	45 – 41	41 – 37	<37
40 – 49	>48	48 – 42	42 – 38	38 – 35	<35
50 – 59	>45	45 – 39	38 – 35	35 – 32	<32
60+	>43	42 – 35	35 – 32	32 – 29	<29
<b><u>WOMEN</u></b>					
<b>Age</b>	<b>High</b>	<b>Good</b>	<b>Average</b>	<b>Fair</b>	<b>Low</b>
20 – 29	>44	44 – 38	38 – 35	35 – 32	<32
30 – 39	>41	41 – 37	37 – 34	34 – 31	<30
40 – 49	>40	39 – 34	34 – 31	31 – 28	<28
50 – 59	>35	35 – 31	31 – 28	28 – 26	<25
60+	>35	35 – 39	29 – 26	26 – 24	<24

# FREERUNNER 5600 ESS CONSOLE

## CONSOLE CODES

There are three groups of console codes which are differentiated according to function. The first group of codes are customization codes and are used to set defaults such as units, language, heart rate input type, etc. The second group of codes are machine status codes and are used to track hours and other general usage patterns for maintenance purposes. The third group of codes are diagnostic codes and are used for troubleshooting. The following key actions are valid in each group of console codes:

- Pressing [LEVEL ^], [ 1<sup>st</sup> # ], [ENTER] displays what group of codes is being accessed.
- Pressing [SELECT] or [LEVEL ^] at that point allows you to view all possible selections. Once in this mode pressing [LEVEL v] backs up through the selections; pressing [ENTER] then selects that item. If another test level is available at this point, the [SELECT] / [ENTER] process is repeated.
- Pressing [^] [1<sup>st</sup> #, or 2<sup>nd</sup> #], [ENTER ] selects that item directly.
- Pressing [CLEAR] exits any of the special access modes.

### Custom Codes

[ ^ ][ 3 ][ 0 ]	change workout time limit between 5 to 99 minutes
[ ^ ][ 3 ][ 1 ]	change units (MPH or KMH)
[ ^ ][ 3 ][ 2 ]	choose type of heart rate input and priority (telemetry or contact)
[ ^ ][ 3 ][ 3 ]	- N/A -
[ ^ ][ 3 ][ 4 ]	choose console language
[ ^ ][ 3 ][ 5 ]	change contrast on console
[ ^ ][ 3 ][ 6 ]	- N/A -
[ ^ ][ 3 ][ 7 ]	- N/A -
[ ^ ][ 3 ][ 8 ]	- N/A -
[ ^ ][ 3 ][ 9 ]	reset to factory defaults

1. Change the workout time by pressing [LEVEL: ^], [ 3 , [0]. The console will display "MAX TIME." Press [ENTER]. The console will then display the current time limit. Use the keypad to enter the desired time, then press [ENTER]. For no time limit, press [0]. The console will display "TIME LIMIT OFF."

## FREERUNNER 5600 ESS CONSOLE

2. Change the units to either Metric or USA units by pressing [LEVEL: ^], [3], [1], [ENTER]. The console will display the current units - either "USA UNITS" or "METRIC UNITS." Use the [SELECT] key to change option, and then press [ENTER].
3. Choose the desired heart rate input preference by pressing [LEVEL: ^], [3], [2]. The console will then display "HR INPUTS." Press [ENTER]. The console will then display the current heart rate input selection. Press the [SELECT] key to scroll through the other options. Press [ENTER] after the desired option.
4. Change the language by pressing [LEVEL: ^], [3], [4]. The console will display "LANGUAGE." Press [ENTER]. The console will then display the current language. Press the [SELECT] key to scroll through the other options. Press [ENTER] to change the option.
5. Adjust the contrast on the LCD screen by pressing [LEVEL: ^], [3], [5]. The console will display "CONTRAST ADJ." Press [ENTER]. The console will then display the current contrast number. Press the [LEVEL: ^], and [LEVEL: v] keys to increase or decrease the contrast. The changed value will remain on exit.
6. Reset the console to factory defaults by pressing [LEVEL: ^], [3], [9]. The console will display "SET DEFAULTS ." Press [ENTER]. Then console will rest itself and then display "DONE."

### Quick Scan Programming

You can quickly access any of the custom menus by pressing [LEVEL: ^], [3], [ENTER]. The console will then display "CUSTOMIZE." Scroll through the following options:

[SELECT] "MAX TIME"	0
[SELECT] "CHANGE UNITS"	1
[SELECT] "HR INPUTS"	2
[SELECT] "LANGUAGE"	4



# FREERUNNER 5600 ESS CONSOLE

[SELECT] "CONTRAST ADJ"	5
[SELECT] "MAX SPEED" - <b>N/A</b> -	6
[SELECT] "CLINICAL MODE" - <b>N/A</b> -	7
[SELECT] "SET DEFAULTS "	9

## Machine Status Codes

[ ^ ][ 4 ][ 0 ]	display machine run time in hours
[ ^ ][ 4 ][ 1 ]	display number of workouts
[ ^ ][ 4 ][ 2 ]	display distance traveled
[ ^ ][ 4 ][ 3 ]	display software rev
[ ^ ][ 4 ][ 4 ]	display machine type
[ ^ ][ 4 ][ 5 ]	<b>-N/A-</b>
[ ^ ][ 4 ][ 6 ]	display machine run time in hours since last cleared (used for maintenance)

1. Display the machine run time by pressing [LEVEL: ^], [4], [0]. The console will display "RUN HOURS XXXXX".
2. Display the number of workouts by pressing [LEVEL: ^], [4], [1]. The console will display "WORKOUTS XXXX."
3. Display the total distance covered up to date by pressing [LEVEL: ^], [4], [2]. The console will then display "DISTANCE XXXX."
4. Display the console software revision number by pressing [LEVEL: ^], [4], [3]. The console will display "CONS 92111-XXX."
5. Display the machine type by pressing [LEVEL: ^], [4], [4]. The console will display "STEPPER (or other machine type)."
6. Display the machine run time since last cleared by pressing [LEVEL: ^], [4], [6]. The console will display "MAINT HOURS XXXX."

# FREERUNNER 5600 ESS CONSOLE

## Quick Scan Programming

You can quickly access any of the custom menus by pressing [LEVEL: ^], [4], [ENTER]. The console will then display "MACHINE STATUS". Scroll through the following options:

[ SELECT ]	" RUN HOURS	XXXX"	0
[ SELECT ]	" WORKOUTS	XXXX"	1
[ SELECT ]	" DISTANCE	XXXX"	2
[ SELECT ]	" CONS	90211- XXX "	3
[ SELECT ]	" FREERUNNER"		4
[ SELECT ]	<b>-N/A-</b>		
[ SELECT ]	" MAINT HOURS	xxxx"	6

## Resetting the Maintenance Hour Counter

For ease of maintenance records, the console has a maintenance timer that will clock the number of hours, workouts, and time between last servicing. After each maintenance period reset the counter.

[ ^ ] [ 7 ] [ 1 ]      Reset Service

1. Reset the maintenance hour counter by pressing [LEVEL: ^], [7], [1]. The console will display "RESET SERVICE." Press [ENTER]. The console will display "DONE." Press [CLEAR] to return to the starting screen.

## Configuration Code

The FreeRunner® console supports other StairMaster® exercise systems. It is important to verify that machine configuration code matches the type of machine you have.

[ ^ ] [ 8 ] [ 0 ]      Change Machine

1. Change the machine type by pressing [LEVEL: ^], [8], [0]. The console will display "CHANGE MACHINE." Press [ENTER]. The console will then display the current machine type. Use the [SELECT] key to toggle between options. Press [ENTER] for the desired option.

# MAINTENANCE INSTRUCTIONS

## HELPFUL HINTS

Read all maintenance instructions thoroughly before beginning work. In some cases, an assistant is required to perform the necessary tasks. All references to the left or right side, and to the front or back, are made as if you were on the machine ready to exercise. For example, the console is located on the front of the machine. Major component names and locations are shown in Figures 18 and 19 in the appendix.

## TOOL LIST

The following tools are needed to perform service and maintenance:

- Standard screwdriver
- Phillips screwdriver
- Alligator Clips
- External snap ring pliers
- Multimeter
- Allen wrench set (sizes 5/64 - 1/4")
- Eye protection
- Torx screwdriver
- Socket set or nut driver set (sizes 1/4 - 3/4")
- Combination wrenches (sizes 7/16 - 3/4")

## MAINTENANCE RECORDS

For ease of maintenance the FreeRunner console will keep track of hours, number of workouts, time between last servicing, etc. You can quickly access any of the custom menus by pressing [LEVEL: ^], [4], [ENTER]. The console will then display "MACHINE STATUS". Scroll through the following options:

[ SELECT ]	" RUN HOURS	XXXX"*	0
[ SELECT ]	" WORKOUTS	XXXX"	1
[ SELECT ]	" DISTANCE	XXXX"	2
[ SELECT ]	" CONS 90211- XXX "		3
[ SELECT ]	" FREERUNNER"		4
[ SELECT ]	<b>-N/A-</b>		
[ SELECT ]	" MAINT HOURS	xxxx"	6

\*The machine may show a few hours of use due to testing at the manufacturing facility.

# MAINTENANCE INSTRUCTIONS

## INITIAL SERVICE

Upon receiving your machine, use a soft, clean towel to wipe off the dust that may have accumulated during shipping. Your new machine will require minor assembly. Refer to the "Installation Instructions" section for details.

## PREVENTIVE MAINTENANCE

A schedule for the recommended preventive maintenance is shown in Table 4. This schedule assumes moderate to heavy usage in a commercial health club environment. Always unplug the power prior to working on the machine. Refer to the "Parts Removal and Replacement" section for all disassembly and assembly instructions.

### Cleaning

1. DO NOT USE GLASS CLEANERS OR ANY OTHER HOUSEHOLD CLEANER ON THE CONSOLE. Clean the console daily with a water-dampened cloth and wipe dry after cleaning.
2. Clean the exterior of the machine daily using soap and water or a diluted household cleaner such as Fantastic®.
3. Thoroughly clean the entire machine, including the interior, at least once a week.

### Inspection

1. Inspect the exposed frame for any rust, bubbling, or paint chips during the weekly cleaning. The salt in perspiration can damage any unpainted surfaces. Repair the damaged area with touch-up paint (PN 22181).
2. Remove the left side cover, and inspect the belts for undue wear and/or fraying during quarterly lubrication. Adjust the alternator belt tension if necessary.

## MAINTENANCE INSTRUCTIONS

3. Carefully turn each of the Poly-V pulleys counterclockwise, and check for smoothness of operation during quarterly lubrication. Reinstall the left side cover.

### Lubrication

The following components need periodic lubrication: the drive chain assemblies, the step chains, the heel link chains, the pedal return springs, pedal shafts, sprockets, and the pedal bushings. Remove the covers to access the components.

1. Place a protective mat on the floor while you lubricate your machine. A rubber floor mat is available from StairMaster® Health & Fitness Products, Inc.
2. Each week lubricate the entire length of the chains, and around each sprocket with an aerosol synthetic chain lubricant (e.g. PJ-1®).
3. Thoroughly clean all of the chains every 3 months. Use a mild degreaser and a stiff brush to remove dirt and corrosion from the chains. Remember to lubricate the chains after cleaning them.
4. To protect the pedal return springs from corrosion, wipe the entire length of each pedal spring with a cloth dampened with 30W motor oil. Replace the spring if it is rusty or otherwise damaged.
5. Remove the pedals every 3 months. Clean the pedal bushings and the pedal shafts. Protect the pedal shafts from corrosion with a thin coat of mineral oil before reassembling.



## WARNING

TO REDUCE THE POSSIBILITY OF SLIPPING, BE SURE THE PEDAL AREA IS FREE OF GREASE OR OIL. WIPE ANY EXCESS OIL OFF THE MACHINE SURFACES.

# MAINTENANCE INSTRUCTIONS

Table 3. Recommended Preventive Maintenance Schedule

PART	RECOMMENDED ACTION	FREQUENCY	CLEANER	LUBRICANT
Belts	Inspect and adjust tension	Every 3 months or 900 hours	N/A	N/A
Covers	Clean and inspect	Daily	Soap and water, diluted household cleaner	N/A
Console	Wipe clean	Daily	Water	N/A
Contact heart rate sensors	Clean and inspect	Each week, or after every 70 hours of use	Clean, dry rag	N/A
Chain assemblies	Lubricate	Each week, or after every 70 hours of use	N/A	Chain lube (e.g. PJ-1®)
	Remove, clean, and lubricate	Every 3 months, or 900 hours of use	Degreaser	Chain lube (e.g. PJ-1)
Pedal shafts	Clean and lubricate	Every 3 months, or 900 hours	Clean, dry rag	Mineral oil
Pedal bushings	Clean and inspect	Every 3 months, or 900 hours	Clean, dry rag	N/A
Sprockets	Clean and lubricate	Each week, or after every 70 hours of use	N/A	Chain lube (e.g. PJ-1)

**Note: Use of lubricants other than those specified will result in diminished performance and a shorter life span for that part.**

# **TROUBLESHOOTING**

## **GENERAL TROUBLESHOOTING GUIDELINES**

This troubleshooting section is organized into five basic sections: Basic Electrical Theory, the Power Control Board, the Systematic Electrical Troubleshooting, Console Diagnostic Tests, and Systematic Mechanical Troubleshooting. Perform the tests in exactly the same order as written. Refer to the "Parts Removal and Replacement" section of this manual for any assembly and disassembly instructions. To order a replacement part or to get help with the troubleshooting process, contact our Customer Service Department at (800) 331-3578. International customers should contact their local distributor or call (425) 823-1825.

## **BASIC ELECTRICAL THEORY**

The power supply takes 110 VAC from the outlet and converts it to 12 VDC for the machine to use. The 12 VDC is then routed up the power supply cable to the power control board, where it is dispersed to perform various duties. The important electrical paths to remember are the 12 VDC path to the alternator, and the 12 VDC path that travels up to the console via the main cable. The power from the main cable turns on the console. Inside the console, a smaller power control board takes the 12 VDC and redirects 5 VDC back down to the lower power control board where it is used to run items that require lower voltages, such as the brake motor. Meanwhile, the voltage routed to the alternator is used to generate a field current. This current is sent back to the power control board, where it is stored and utilized by the console to "pulse" the load resistor. Depending on the input from the user, the console varies the duty cycle of the load resistor. The duty cycle refers to the length of time that the console allows the resistor to collect and dissipate electrical energy. The more it absorbs and disperses the harder the workout for the machine user.

## **THE POWER CONTROL BOARD**

The power control board on the 5600 ESS is equipped with a 10-segment Light Emitting Diode (LED) bar graph to be used as a troubleshooting tool. These 10 LEDs are designated from right to left. Nine of the ten LEDs will be illuminated while the machine is at rest and the brake is engaged. The tenth LED will never be illuminated. The LED bar graph can help in giving you direction toward troubleshooting and repairing the 5600 ESS.

### **LED #1 - V Supply**

The purpose of this LED is to show whether or not power is reaching the power control board. If this LED is not illuminated, then there is no power to the power control board. The console will be off and the other nine LEDs will not be illuminated. Test the outlet for proper voltage first, then test the power supply. Next check the power connector cable and then the power control board itself.

### **LED #2 - VCC**

The purpose of this LED is to indicate whether or not power is going from the power control board to the console and back down to the power control board. If it is not lit then 12 VDC is not leaving the power control board to the console and returning as 5 VDC. Under this condition, the console will have nothing on display. Check for continuity and proper voltage in the upper and lower main cables first. If the cables are good, then check the console. If the console is good then check the power control board.

### **LED #3 - Alt Off**

The purpose of this LED is to show if the alternator is being activated. The LED will remain illuminated. When an exercise program begins, the LED will turn off, indicating that the alternator's field has been engaged, providing workout resistance. If the LED is off and no workout program is being executed, then check the console and the upper and lower main cables. If the LED is illuminated and you still experience resistance problems, then check the power control board, alternator cable, and the alternator.

### **LED #4 - RLOAD**

The purpose of this LED is to indicate that the power control board is receiving a signal from the alternator and the load resistor. This LED is different from the others because it will dim and brighten. The LED will be at its brightest when the machine is at rest. You will notice during a workout program the brightness of the LED will begin to fade as the



## TROUBLESHOOTING

intensity level increases. If the LED is off, check the console and the upper and lower main cables. If the LED is illuminated and you still experience resistance problems, check the power control board, load resistor wires, load resistor, and the alternator.

### **LED #5 - SS**

The purpose of the "SS," or "Stride Sensor" LED is to indicate whether or not the stride sensor magnet is aligned with the stride sensor control board. The stride sensor magnet will be in alignment with the stride sensor control board every time the pedals are at their lowest point. If the LED is not lit and the pedals are at their lowest point, then there is a problem with the stride sensor board alignment, the stride sensor cable, the leg sprocket magnet, the power control board, or possibly the console or other cables. Verify that the stride sensor board is .25 - .30 inches away from the leg sprocket magnet, then systematically go through the other possible causes.

### **LED #6 - Mtr Dir**

The purpose of this LED is to indicate that the console software is correctly controlling the brake motor. If you press one of the workout keys on the console the brake will disengage, and this LED will turn off and remain off until the brake is engaged again at the end of the workout. If the LED is off while the brake is engaged, check the console and upper and lower main cables. If the LED functions properly when a key is pressed but the pedals remain locked, check the power control board, brake motor, upper and lower limit switches.

### **LED #7 - Motor On**

This LED is used to indicate that the brake motor is being activated to rotate the brake cam between the upper and lower limit switches. Each time the brake motor is activated the LED will momentarily turn off. If the LED is off check the console and the upper and lower main cables. If the LED functions properly and the motor does not activate, check the power control board, brake motor, and upper and lower limit switches.

### **LED #8 and LED #9**

These last two LEDs are used for indicating that the brake system is being activated using the upper and lower limit switches. The LEDs remain illuminated at all times (except while the brake motor is in motion). If a workout key on the console is pressed, LED #9 will momentarily turn off while the brake cam rotates to the upper limit switch. When a workout program is completed or is exited, the LED #8 momentarily turns off and the brake motor cam rotates to the lower limit switch engaging the brake system. A software code can also be used to test the limit switches (see Brake Test pg.48).

### **LED #10 - Not Used**

This LED is not used for troubleshooting. It will remain off at all times.

# TROUBLESHOOTING

## SYSTEMATIC ELECTRICAL TROUBLESHOOTING

The electrical system has six major components: the power supply, the power cables, the alternator, the power control board, the console, and the load resistor. In order to identify the component that is causing the problem, you must systematically test the entire system. You will need a multimeter to conduct portions of the following procedures. The console, power supply, and power control board are not user serviceable. If any of these parts are inoperable, they must be replaced. Opening the console or the power supply will void the warranty.



TO REDUCE THE RISK OF ELECTRICAL SHOCK, A QUALIFIED ELECTRICIAN SHOULD PERFORM ALL ELECTRICAL TESTS THAT INVOLVE CHECKING AC POWER.

1. Disconnect the AC power cord (from the power supply) from the AC wall outlet.
2. Use a multimeter to verify that the AC line voltage of the wall outlet is between 108 and 130 VAC (208 and 240 VAC, if applicable). Consult an electrician for further assistance if the voltage is outside the range specified or if an alternate AC device (a lamp, for example) does not work when plugged into the AC wall outlet.
3. Plug the AC power cord back into the wall outlet.
4. Disconnect the power supply from the machine. Use a multimeter to verify approx. 15-16 VDC at the end of the power supply cable. Pin #1 is negative, and pin #2 is positive. Replace the power supply if the reading is under the specified range or no voltage reading at all.
5. Remove the left side cover and reconnect the power supply to the machine.

## TROUBLESHOOTING

6. Locate the black and white power connector wires on the power control board. Unplug the connector from the board and verify approx. 15-16 VDC between pin #1 (negative) and pin #2 (positive). Replace the power connector if the reading is under the specified range or no voltage reading at all.
7. Verify that all of the alternator connections are tight and in the correct location.
8. Inspect the power control board for loose connections.
9. Remove the console and use a multimeter to measure approx 15-16 VDC between pin #1 (negative) and pin #10 (positive) of the upper main cable (see diagram below). If no voltage is displayed, look at LED #1 (Vsupply) on the lower power board and verify that it is lit (see page 40). If it is lit, disconnect the main cable from the power board and measure approx. 15-16 VDC between pin #10 (negative) and pin #2 (positive) on the main cable connector J1 of the power board. If the voltage is correct, replace the upper and lower main cables. If there is no voltage, replace the power board.

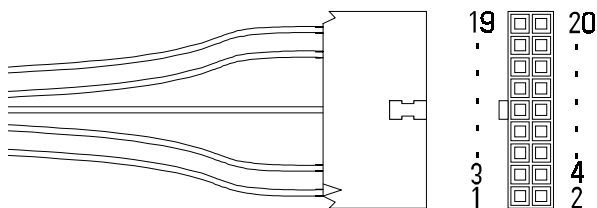

10. If all voltage readings have been within the specified range and the console will not power up, the console should be replaced.
11. Perform the following Positive Output to Field test on the alternator:
  - Turn the power off.
  - Disengage the brake.
  - Remove the white wire from the B+ terminal on the alternator.
  - Remove the brown wire from the field (FLD) terminal on the alternator.



## TROUBLESHOOTING

- Place alligator clips on the B+ terminal and the field terminal of the alternator.
  - Step on the machine for 15 - 20 seconds.
  - If resistance is achieved during this time, your alternator has correct current flow.
  - If no resistance builds up during this time, you either have a bad alternator or bad alternator brushes.
12. Unplug the diode from the FLD terminal of the alternator.
  13. Use a multimeter set to ohms to test the diode. A good diode will show a high resistance reading in one direction and a low resistance reading when the multimeter leads are reversed.
  14. Unplug the load resistor from the power control board. Set your multimeter to ohms. Insert the multimeter leads into the load resistor plug.
  15. A load resistor in proper working condition should read approximately 0.5 ohms. If there is no resistance when measured by a multimeter, replace the load resistor.
  16. Check the main cable assemblies for continuity and cross check each wire in the cables to test for shorts in the cable.
  17. Contact our Customer Service Department at (800) 331-3578 for assistance. International customers should contact their local distributors.

## CONSOLE CODES

The following tests are performed while the console is in the "SELECT WORKOUT" mode. If the console fails any test, the console should be replaced or exchanged. To return to the "SELECT WORKOUT" mode, press either [CLEAR] or [STOP] while in the DIAGNOSTIC mode. Please note that there may be additional verbiage on the display other than is listed in this manual. The FreeRunner console is used on other StairMaster® equipment.

### Diagnostic Codes

- [^][6][0] Test display
- [^][6][1] Test keyboard
- [^][6][2] Test serial port
- [^][6][3] Test alternator
- [^][6][4] Test continuous brake cycle
- [^][6][5] Test brake on/off position
- [^][6][6] - [6][9] -N/A-

### The Display Test

During the display test, the console screen alternates between all LCD segments turned on, and sample program profile screen at a 2-second rate.

1. Press [LEVEL: ^], [6], [0], [ENTER]. The console will display "DISPLAY TEST".
2. All LCD segments will turn on for 2 seconds and then a sample program profile will be displayed for 2 seconds. Press [CLEAR] to end the test.

### The Keypad Test

Perform this test if you are having trouble entering data into the console. During the test, pressing any key displays that key name on the message line. Press [CLEAR] to exit.

1. Press [LEVEL: ^], [6], [1], [ENTER] to start the test.

## TROUBLESHOOTING

2. Firmly press each button except [CLEAR]. The name of the key will be shown in the display window. Press [CLEAR] to end the test.

### The Serial Port Test

This test verifies that the RS 232 port used for linking to commercial entertainment systems is working. You must have the loop-back cable assembly, pn 040051-001 to perform this test.

1. Insert the loop-back cable assembly into the RS 232 port on the back of the console.
2. Press [ LEVEL: ^ ], [ 6 ], [ 2 ], [ENTER]. The console will display "C.S.A.F.E. TEST." Press [ENTER] a second time.
3. The console will run a diagnostic test and then display either "PASS" or "FAIL". Replace the console if it fails this test.

### The Alternator Test

Use this test to verify the alternator field routines of the console. You will need to briefly exercise on the machine for this test.

1. Press [ LEVEL: ^ ], [ 6 ], [ 3 ], [ENTER] to start the test.
2. For "Field on" press [ LEVEL: ^]. Step on the machine for approximately 10 to 15 seconds. If full resistance is achieved during this time, your console has correct current flow. If no resistance is achieved, either the console or the alternator is bad. See the electrical troubleshooting portion of this manual to isolate and test the alternator. Replace the console if the alternator is good.
3. For "Field off" press [ LEVEL: V]. Step on the machine for approximately 10 to 15 seconds. You should not get resistance with the field turned off. Press [CLEAR] to end the test.

## The Brake Tests

Use this test to verify that the brake limit switches are triggered correctly. Adjust the limit switches if these tests fail. For replacement procedures refer to the cable section of "Parts Removal and Replacement."

### Continuous cycle verification:

1. Remove the left side cover.
2. Position pedals so that they are bottom-dead-center. The software picks up a signal from the stride sensor and will not allow braking if the stride sensor detects that the pedals are apart.
3. Press [ LEVEL: ^ ], [ 6 ], [ 4 ], [ ENTER ] to cycle the motor continuously. Verify that the brake cam is triggering the upper and lower limit switches and that the cam is not hitting the mechanical stops (see Figure 30).
4. Press [ CLEAR ] to end the test.

### Brake "ON" and Brake "OFF" verification:

5. Press [ LEVEL: ^ ], [ 6 ], [ 5 ], [ ENTER ] to start the test. Press the [ LEVEL: ^ ] key. Verify that the "Motor Dir" LED (#6) turns on and stays on, and that the "Motor On" LED (#7) turns off for approximately 2 seconds and then turns on and stays on.
6. Press the [ LEVEL: v ] key. Verify that the "Motor Dir" LED (#6) turns off and stays off, and that the "Motor On" LED (#7) turns off for approximately 2 seconds and then turns on and stays on.
7. Press [ CLEAR ] to end the test. Reinstall the side cover.





## TROUBLESHOOTING

### Error Reporting

The console will display various error messages in the display window. The total amount of errors will be displayed in the upper right numeric window. Note that only the highest priority reported error will be displayed. Errors are handled in two ways. One as a non-fatal "WARNING" which will display the text message but continue system operation until the user presses the [CLEAR] key. The second way is as a fatal "ERROR" which will stop the exercise and return the system to an idle intensity state. The console will display the error text and not let the user restart the programs unless power has been turned off and then back on.

The following microprocessor errors require a console replacement; ALU ERROR, TIMER ERROR, and STATIC RAM ERROR.

Resetting the power may clear the following microprocessor errors; EEPROM ERROR, and PROGRAM ERROR. If resetting the power doesn't work, the console may need to be replaced.

### Telemetry (Polar®) Heart Rate

The telemetry heart rate system is made up of the console, the heart rate receiver, and the chest strap (available separately). You can test each component by performing the following steps:

1. You will need to put a chest strap on in order to test the telemetry heart rate. Before you put on the chest strap, wet the two contact patches. Secure the chest strap as high under your pectoral muscles (chest) as is comfortable. The chest strap should fit snugly, comfortably, and allow normal breathing.
2. A flashing ♥ should be displayed on the console. Your heart rate, in beats per minute, will show next to the heart icon. If the heart icon does not show, or if your heart rate is not displayed on the console then you have a problem with either the console, chest strap, or heart rate receiver.
3. Verify that the console software has been set up to receive telemetry (see the heart rate monitoring section of this manual). Note that holding the contact heart rate sensors (if enabled) can inhibit the telemetry heart rate input from working.
4. Test your chest strap with a machine that you know is working, or with a heart rate watch that you know is working.
5. External interference caused by nearby televisions, personal CD players, or air conditioners may also inhibit the telemetry heart rate pickup. Move the machine away from interference sources if possible.
6. If possible, replace or exchange your console with a console that you know is working and retest the machine.
7. Excess false heart rate detection: the telemetry receiver located inside the console is susceptible to mechanical vibration as well as external electrical interference. Hitting the console or the frame may momen-



## TROUBLESHOOTING

tarily cause errant heart beat detection - this is normal. If excessive false heart beats appear only during workouts, remove the console and verify that the main cable is not curled up behind it. Tuck as much of the main cable length inside the handlebar as possible before replacing the console. False heart beats while the machine is idle are most likely due to external interference. Try plugging the machine into a different electrical outlet, or moving the machine to a different location.

## SYSTEMATIC MECHANICAL TROUBLESHOOTING

If you hear a grinding or clicking noise or experience excessive vibration during exercise, a problem exists in the drive train of your machine. Isolate the problem area by performing the following tests in precisely the order listed below. Refer to the appropriate "Parts Removal and Replacement" section of this manual for all disassembly and assembly instructions.



**TO REDUCE THE RISK OF INJURY, DO NOT OPERATE THE MACHINE WHILE THE COVERS ARE REMOVED. DO NOT MOVE THE PEDALS WHILE ANYONE'S HANDS ARE INSIDE THE MACHINE.**

1. Remove the base and side covers.
2. Remove the upper and lower Poly-V belts, and inspect the belts for cracks and/or fraying. A worn belt could cause the loss of resistance - replace if necessary.
3. Verify that the brake is off, and spin the alternator pulley. The pulley should spin freely four to five revolutions without any clicking or grinding noises. Replace the alternator if any noises within the alternator are heard.
4. Spin the intermediate and lower Poly-V pulleys. The pulleys should spin freely without any clicking or grinding. Replace the pulley(s) if any noises are heard.
5. Inspect the step chains, heel link chains, and the drive chain assemblies for frozen links and/or corrosion. Pay particular attention to areas of high wear. For example, the section of chain that contacts the sprockets during operation. Replace a chain if any problems are found.
6. Inspect the pedal return springs for corrosion. Clean corrosion off the springs with fine steel wool. Replace the springs if the metal is pitted.



## TROUBLESHOOTING

7. Rotate the drive sprockets (see Figure 19). Each sprocket should lock in one direction and rotate freely in the reverse direction. Inspect the drive shaft for wear when replacing a failed clutch sprocket.
8. Check the pedal shafts and bushings by removing the pedal (see Figure 22). Inspect the shafts and bushings for signs of wear and corrosion. Clean corrosion off the pedal shafts with fine steel wool and replace any worn bushings before reassembling. **DO NOT SAND THE PEDAL SHAFT.**
9. Reinstall all parts, ensuring proper tension of the Poly-V pulley belts and that the top edge of the heel link pivot assembly is parallel with the floor (see Figure 25). Lubricate all chain assemblies.
10. Contact our Customer Service Department at (800) 331-3578 for assistance. International customers should contact their local distributors.

# PARTS REMOVAL AND REPLACEMENT

## ALTERNATOR

1. Remove the left side cover.
2. Mark the location of each wire attached to the alternator (see Figure 34). Remove the wires and the diode from the alternator.
3. Remove the brake mounting bolt from the alternator (see Figure 11).
4. Remove the alternator adjusting bolt from the slotted brace (see Figure 11). Loosen the pivot bolt on the alternator. Pivot the alternator down.
5. Remove the upper Poly-V belt. Inspect the belt for wear and replace the belt if it is cracked, cut, or otherwise damaged.
6. Remove the pivot bolt from the alternator, and then remove the alternator from the frame.
7. Reverse the removal procedures to install the new alternator. Remember to verify the wiring.
8. Pivot the alternator up or down as necessary to allow  $\frac{1}{4}$ " (0.6 cm) of belt deflection at the midpoint between the two pulleys.

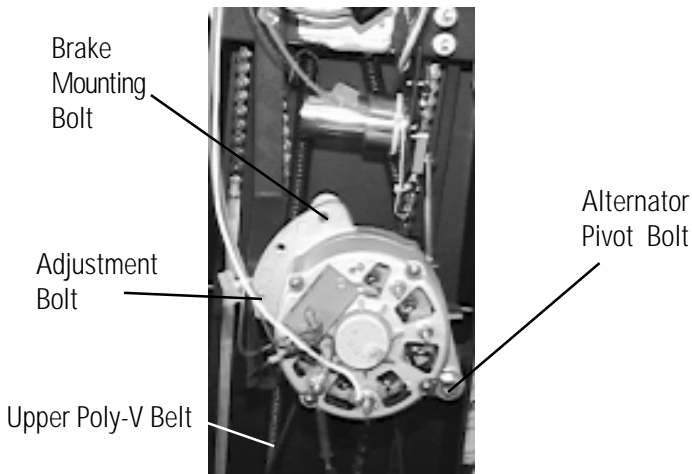

Figure 11: Alternator Mounting



# PARTS REMOVAL AND REPLACEMENT

## BEARINGS

### **Bearing Block – Heel Link**

1. Remove the side cover.
2. Remove the pedal shaft housing from the pedal and pivot the pedal forward.
3. Remove the heel link flange bearing, jam nut, and heel link sprocket. Use the heel link turnbuckle to loosen the heel link chain. Keep track of the shaft key.
4. Remove the heel link from the bearing block assembly.
5. Remove the four mounting screws from the bearing block assembly and set the bearing block assembly aside.
6. Install the new bearing block assembly, reassemble the machine, and adjust the top edge of the heel link pivot assembly so that it is parallel with the floor (see Figure 27).

### **Bearing Block – Leg Assembly**

1. Remove the pedal and the side cover.
2. Loosen the drive chain turnbuckle.
3. Remove the leg link flange bearing. Remove the jam nut and washer from the leg assembly shaft.
4. Remove the leg assembly from the bearing block assembly.
5. Remove the four mounting screws from the bearing block assembly.
6. Install the new bearing block assembly, reassemble the machine, and adjust the top edge of the heel link pivot assembly so that it is parallel with the floor (see Figure 27).

## PARTS REMOVAL AND REPLACEMENT

### Flange Bearing – Heel Link

1. Remove the appropriate side cover.
2. Loosen the two set screws on the flange bearing.
3. Remove the two mounting screws and washers from the bearing housing and slide the flange bearing assembly off the heel link shaft.
4. Install the new flange bearing assembly in the bearing housing and tighten the set screws. Reinstall the side cover.

### Flange Bearing – Leg Assembly

1. Remove the appropriate side cover.
2. Loosen the two set screws on the flange bearing.
3. Remove the two mounting screws and washers and slide the flange bearing assembly off the leg shaft.
4. Install the new flange bearing assembly and tighten the set screws.
5. Reinstall the side cover.

## BELTS



THE BELTS MUST BE PROPERLY TENSIONED. A BELT THAT IS TOO TIGHT WILL CAUSE SLOW AND SLUGGISH OPERATION. A BELT THAT IS TOO LOOSE WILL CAUSE EXCESSIVE NOISE AND BELT WEAR.

### Upper Poly-V Belt

1. Remove the left side cover.



## PARTS REMOVAL AND REPLACEMENT

2. Loosen the alternator screw and mounting bolt. Pivot the alternator down.
3. Remove the upper Poly-V belt (see Figure 12).
4. Reinstall the belt. Pivot the alternator up or down as necessary to allow  $\frac{1}{4}$ " (0.6 cm) deflection at the midpoint between the two pulleys (see Figure 20).
5. Reinstall the cover.

### Lower Poly-V Belt

1. Remove the left side cover and then remove the upper Poly-V belt.
2. Push the idler pulley away from the belt (see Figure 12) and remove the lower Poly-V belt. Install the new belt, and then reinstall the upper Poly-V belt. Verify proper tension on the upper belt (see Figure 20).
3. Ensure that the belt grooves are seated in the pulley grooves, and that the outside edge of the lower belt is flush with the outside face of the lower Poly-V pulley. Reinstall the cover.

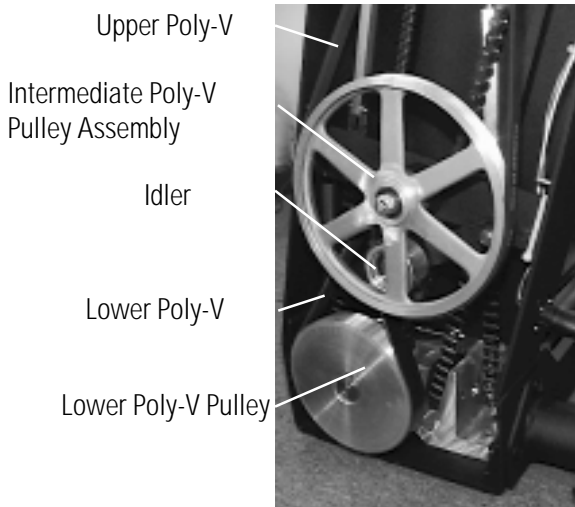

Figure 12: Belt Location

# PARTS REMOVAL AND REPLACEMENT

## BRAKE SYSTEM

### Brake Actuator Arm

1. Remove the left side cover.
2. Remove the brake cam mounting screw from the top of the brake actuator arm.
3. Loosen the jam nut from the center of the actuator arm, and remove the lower screw (see Figure 13).
4. Install the new arm.
5. Use the brake actuator spring nut and /or the lower mounting nut to adjust the throw on the arm to properly engage/disengage the brake (see Figure 13).

### Brake Motor

1. Remove the left side cover.
2. Remove the brake actuator arm.
3. Remove the brake cam mounting screw and slide the cam off the brake motor shaft (see Figure 13).
4. Unplug the motor cable from the power control board, remove the mounting bolts from the motor, and remove the motor from the frame.
5. Install the new motor and reassemble the machine.
6. Use the brake actuator spring nut and/or the lower mounting nut to adjust the throw on the arm to properly engage/disengage the brake (see Figure 13).

## PARTS REMOVAL AND REPLACEMENT

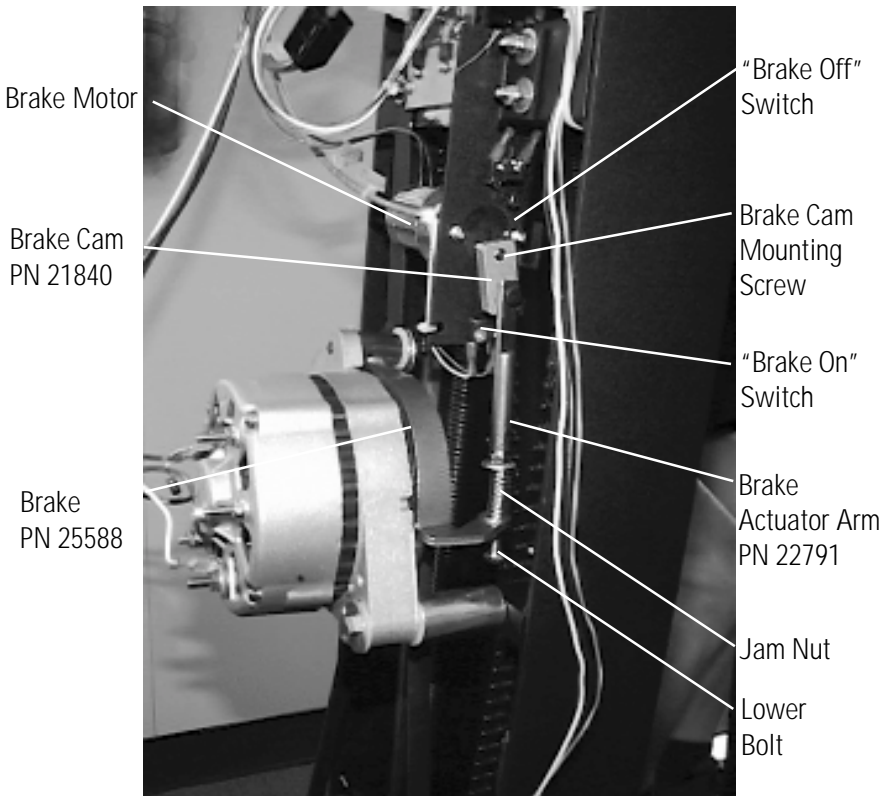

**Figure 13: Brake Location**

### Brake

1. Remove the left side cover. Remove the brake actuator arm from the brake.
2. Remove the mounting bolt from the brake and lift the brake off the alternator flywheel.
3. Install the new brake and reassemble the machine.
4. Use the brake actuator spring nut and/or the lower mounting nut to adjust the throw on the arm to properly engage/disengage the brake (see Figure 13).

# PARTS REMOVAL AND REPLACEMENT

## CABLES

### Alternator Cable

1. Remove the left side cover.
2. Unplug the alternator cable from the power control board.
3. Remove the wiring from the alternator, noting the origin and color of the wires removed from each terminal.
4. Install the new cable and verify the wiring connections (see Figure 34).
5. Reinstall the cover.

### Upper Main Cable

1. Remove the left side cover and the console.
2. The upper main cable splits into two cable assemblies at the bottom of the cable assembly. Disconnect the upper main cable from the lower main cable inside the left frame. Disconnect the brake cable (part of the main cable assembly) from the lower brake cable inside the left frame.
3. Pull the upper main cable out through the console handlebar.
4. Thread the new cable through the console handlebar, and connect the upper and lower main cables, and the upper and lower brake cables.
5. Connect the upper main cable to the console. Reinstall the console and the cover.

# PARTS REMOVAL AND REPLACEMENT

## Lower Brake Cable

1. Remove the left side cover.
2. Disconnect the upper brake cable from the lower brake cable. Unplug the lower motor cable from the power control board.
3. Install the new cable and reinstall the side cover.

## Lower Main Cable

1. Remove the left side cover and disconnect the upper main cable from the lower main cable.
2. Unplug the lower main cable from the power control board and pull the cable away from the machine.
3. Install the new lower main cable and use a tie wrap to secure the cable away from the leg sprocket.
4. Reinstall the cover.

## Limit Switch Cable

1. Turn the power off and remove the left side cover.
2. Unplug the motor cable and the limit switch cable from the power control board (see Figure 31).
3. Remove the mounting screws from the upper and lower limit switches and remove the limit switch assembly.
4. Install the new limit switch assembly.

***Note: The " Brake On" switch is positioned on the machine below the "Brake Off" switch. Do not reverse the switches during installation - see Figure 27.***



## PARTS REMOVAL AND REPLACEMENT

5. Use the mounting screws to adjust the upper and lower limit switches so that the brake cam triggers the limit switches first before it hits the mechanical stops (see Figure 14).
6. Turn the power on. Press [ LEVEL: ^ ], [ 6 ], [ 5 ], [ ENTER ] to start the test. Press the [ LEVEL: ^ ] key. Verify that the "Motor Dir" LED (#6) turns on and stays on, and that the "Motor On" LED (#6) turns off for approximately 2 seconds and then turns on and stays on.
7. Press the [ LEVEL: ∨ ] key. Verify that the "Motor Dir" LED (#6) turns off and stays off, and that the "Motor On" LED (#6) turns off for approximately 2 seconds and then turns on and stays on.
8. Press [ CLEAR ] to end the test.
8. If necessary, use the actuator arm spring nut and/or the lower mounting nut on the actuator arm to adjust the throw of the arm to rotate the brake cam correctly. Reinstall the cover.

## PARTS REMOVAL AND REPLACEMENT

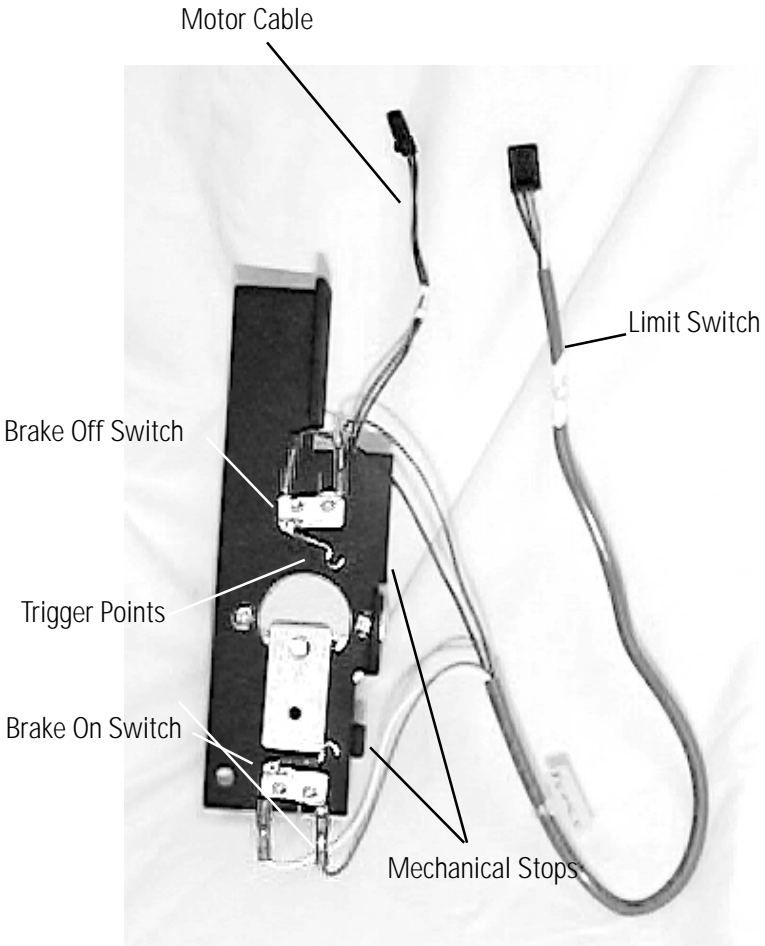

**Figure 14: Limit Switch Assembly**

### **Power Connector Cable**

1. Remove the left side cover.
2. Unplug the power connector from the power control board.



## PARTS REMOVAL AND REPLACEMENT

3. Remove the four mounting screws and grounding screw from the frame. Remove the power connector cable from the frame.
4. Install the new cable, secure the grounding screw, and reinstall the side cover.

### Stride Sensor Cable

1. Remove the left side cover.
2. Unplug the cable from the stride sensor board. Remove it from the power control board.
3. Install the new cable and reinstall the side cover.

## CHAINS

### Upper Heel Link Chains

1. Remove the pedal and the appropriate side cover.
2. Remove the power control board (left side only).
3. Loosen the heel link turnbuckle.
4. Remove the heel link flange bearing.
5. Unhook the extension spring from the spring hanger.
6. Remove the jam nut and washer from the heel link shaft (see Figure 23).
7. Support the upper heel link sprocket and remove the heel link from the heel link bearing block.
8. Disconnect the master links from the upper heel link chains and install the new chains.



## PARTS REMOVAL AND REPLACEMENT

9. Reinstall the heel link and ensure that the heel link shaft key is fully inserted into the key way. Reconnect the extension spring to the frame.
10. Adjust top edge of the heel link pivot assembly so that it is parallel with the floor (see Figure 27).

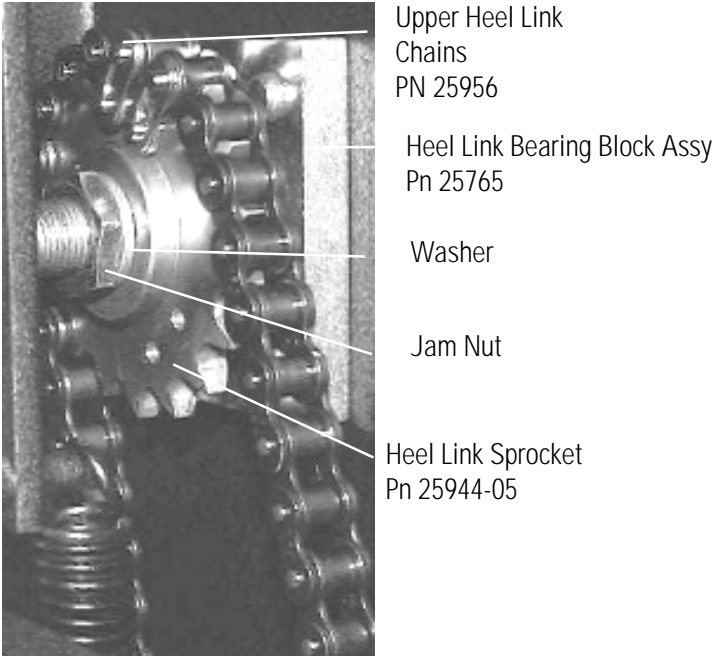

**Figure 15: Upper Heel Link Chains**

### Lower Heel Link Chains

1. Remove the base and side covers.
2. Rotate the heel link turnbuckle to slacken the chain.

***Note: It may be necessary to rotate the heel link turnbuckle both directions to see which way will loosen the chain.***

## PARTS REMOVAL AND REPLACEMENT

3. Disconnect the single pitch master links from each end of the chain. Pull the chain away from the lower heel link sprocket.
4. Install the new chain. Adjust the top edge of the heel link pivot assembly so that it is parallel with the floor (see Figure 27).
5. Reinstall the covers.

### Front Drive Chain Assembly

1. Remove the side and base covers.
2. Rotate the drive chain turnbuckle to loosen the drive chain. Remove the front drive chain master link from each leg sprocket.
3. Disconnect the master links from the turnbuckle and from the chain adapter link.
4. Pull the lower chain out from under the drive chain idler sprockets (see Figure 21).
5. Install the new drive chain assembly. Adjust the drive chain turnbuckle so that the chain does not slap the frame during a moderate paced workout.

***Note: Do not over-tighten – over-tensioning the turnbuckle will cause the machine to feel rough and cause premature wear of components.***

6. Reassemble the machine, and adjust the top edge of the heel link pivot assembly so that it is parallel with the floor (see Figure 27).

***Note: There are two types of master links. Do not interchange single pitch master links with the double pitch master links (see Figure 26).***

### Rear Drive Chain Assembly

1. Remove the side and base covers.



## PARTS REMOVAL AND REPLACEMENT

2. Rotate the drive chain turnbuckle to loosen the drive chain assembly.
3. Remove the rear drive chain master links from each leg sprocket.
4. Remove each pedal spring from the spring hanger and disconnect each step chain from each drive chain adapter link.
5. Disconnect the master links from each end of the chain adapter links, and pull the lower chain out from under the drive chain idler sprockets (see Figure 21).
6. Install the new chain assembly, and adjust the drive chain turnbuckle so that the chain does not slap the frame during a moderate paced workout.

***Note: Do not over-tighten – over-tensioning the turnbuckle will cause the machine to feel rough and cause premature wear of components.***

7. Reassemble the machine, and adjust the top edge of the heel link pivot assembly so that it is parallel with the floor (see Figure 27).

***Note: There are two types of master links. Do not interchange single pitch master links with double pitch master links (see Figure 26).***

### Step Chains

1. Remove the side cover.
2. Reach between the alternator and the main frame (left side only) to pull up on the spring and remove it from the spring hanger.
3. Detach the spring from the step chain by removing the single pitch master link.
4. Detach the step chain from the drive chain adapter link by removing the single pitch master link.



## PARTS REMOVAL AND REPLACEMENT

5. Pull the chain away from the drive sprocket and install the new chain.
6. Reinstall the spring and verify that the spring is seated in the spring hanger groove.

***Note: If you are having difficulty removing the left spring, remove the power control board for more accessibility.***

### CONSOLE

1. Remove the four mounting knobs and lock washers from the back of the console.
2. Lift up the console and disconnect the main cable and the left and right contact heart rate cables (if applicable).

### CONSOLE HANDLEBAR

1. Remove the console and the side covers.
2. Disconnect the upper main cable from the lower main cable and the lower brake cable.
3. Remove the main cable and the Polar heart rate cable from the console handlebar.
4. Have an assistant support the handlebar. Remove the bolts and washers from each end of the handlebar. Gently pull the handlebar away from the machine.
5. Install the new handlebar and connect all cables. Ensure that the cables are not pinched between the frame and the handlebar, and are not in the way of moving parts.
6. Reinstall the console and the covers.

# PARTS REMOVAL AND REPLACEMENT

## COVERS



TO REDUCE THE RISK OF INJURY, DO NOT OPERATE THE MACHINE WHILE THE COVERS ARE REMOVED. DO NOT MOVE THE PEDALS WHILE ANYONE'S HANDS ARE INSIDE THE MACHINE.

### Base Cover

1. Remove the side covers.
2. Remove the two mounting rivets located on the lower front side of the frame.
3. Lift the bottom cover up to detach it from the frame.
4. Pull the cover out and away from the frame.

### Heel Link Cover

1. Remove the two mounting screws from the cover, and then remove the old cover.
2. Install the new cover using the two mounting screws.

### Safety Panel

1. Remove the fasteners from the inside edge of the safety panel.
2. Slide the panel out from behind the heel link pivot assembly and install the new panel.

### Side Cover

1. Remove the top cover.
2. Loosen the wing nuts holding the top of the side cover in place.

## PARTS REMOVAL AND REPLACEMENT

3. Lift the side cover up and remove it from the frame.
4. Install the new side cover by aligning the cover hooks with the frame pins and tightening the wing nuts. Reinstall the top cover.

### DRIVE SHAFT ASSEMBLY

1. Remove all the covers.
2. From the left side, remove the lower Poly-V belt.
3. Remove the snap ring from the drive shaft, back the lower Poly-V pulley set screw out and slide the pulley off the drive shaft (see Figure 21).



TO REDUCE THE RISK OF EYE INJURY, WEAR EYE PROTECTION WHEN REMOVING SNAP RINGS.

4. Disconnect the left and right spring from their respective spring hangers. Disengage the step chain from the drive sprockets.
5. Remove the drive sprocket, thrust washers, thrust bearings, and spacers from the drive shaft (see Figure 21).
6. From the right side, remove the snap ring, washers, bearings, drive sprocket from the drive shaft and slide the shaft out from the frame.
7. Install the new shaft and reassemble the machine.

### HANDLE ASSEMBLY

1. Remove the two bolts from the handle.
2. Remove the handle from the leg assembly.

# PARTS REMOVAL AND REPLACEMENT

## HANDLE KNOB ASSEMBLY

1. Remove the handle assembly.
2. Remove the shoulder washer from each side of the handle yoke (see Figure 28).
3. Pull the handle adjustment knob out and slide the yoke out of the handle.
4. Remove the knob. Do this by inserting a phillips screwdriver or small shaft into the handle knob pin to prevent it from spinning while you rotate the knob counterclockwise. Remove the o-ring from the knob pin.
5. Remove the knob pin from the inside of the handle. Slide the spring off the knob pin.
6. Install the new handle knob assembly on the handle and align the handle yoke groove with the knob pin. Ensure that the groove on the yoke faces out, towards the console (see Figure 28).
7. Slide the yoke into the handle and verify that the knob shaft locks into each handle position.

## HEEL LINK

1. Remove the pedal (see Figure 24).
2. Remove the snap ring from the heel link pivot assembly.



TO REDUCE THE RISK OF EYE INJURY, WEAR EYE PROTECTION WHEN REMOVING SNAP RINGS.

3. Separate the heel link from the pivot assembly.

## PARTS REMOVAL AND REPLACEMENT

4. Install the new heel link and reinstall the pedal. Remember to lubricate the pedal shaft with mineral oil before installing the pedal.

### Heel Link Pivot Assembly

1. Remove the pedal.
2. Remove the safety panel and side cover.
3. Remove the heel link flange bearing and unhook the extension spring.
4. Remove the jam nut and washer from the pivot assembly shaft (see Figure 23).
5. Remove the heel link sprocket, with the chain attached, from the pivot assembly shaft.
6. Pull the pivot assembly out from the heel link bearing block.
7. Install the new pivot assembly, and ensure that the pivot shaft key is fully inserted into the key way. Reassemble the machine in reverse order.
8. Adjust the top edge of the heel link pivot assembly so that it is horizontal with the floor (see Figure 27).

### LEG ASSEMBLY

1. Remove the pedal assembly.
2. Remove the side cover.
3. Remove the spring from the spring hanger, and loosen the drive chain assembly turnbuckle (see Figure 19).
4. Loosen the leg sprocket set screws (see Figure 20).





## **PARTS REMOVAL AND REPLACEMENT**

5. Remove the leg assembly flange bearing.
6. Remove the jam nut and washer from the leg assembly shaft.
7. Stand by the leg assembly, and pull the leg shaft out from the bearing block. The leg sprocket will drop onto the frame brace.
8. Install the new leg assembly and ensure that the leg assembly shaft key is fully inserted into the key way.
9. Reassemble the machine by reversing steps 1 through 8, and adjust the top edge of the heel link pivot assembly so it is parallel with the floor (see Figure 27).

## **LOAD RESISTOR**

1. Remove the left side cover and unplug the load resistor from the power control board.
2. Remove the two mounting screws from the resistor and remove the load resistor.
3. Install the new load resistor.
4. Plug the load resistor back into the power control board and reinstall the side cover.

## **MOUNTING BLOCKS**

1. Remove the covers. Have an assistant help you prop the front of the machine up approximately 4 - 8 inches with wooden blocks. Be careful not to block access to the mounting screws!
2. Remove the front and rear drive chain assemblies.
3. Remove the step chains and heel link chains.

## PARTS REMOVAL AND REPLACEMENT

4. Remove the drive shaft assembly.
5. Remove the mounting block screws and washers from the bottom of the machine, and remove the mounting blocks.
7. Remove the heel link idler sprockets and the drive chain idler sprockets from the mounting blocks.
8. Attach the drive chain idler sprockets and the heel link idler sprockets to the new mounting blocks.
9. Install the new mounting blocks. Do not reverse the right and left mounting blocks.
10. Reassemble the machine in reverse order, and adjust the top edge of the heel link pivot assembly so it is parallel with the floor (see Figure 27).

### PEDAL ASSEMBLY

1. Disengage the brake and push the pedals apart.
2. Remove the six cover fasteners from the pedal cover, and lift the cover, with the foot strap, off the pedal support (see Figure 25).
3. Remove the foot strap mounting fasteners from under the pedal cover.
4. Remove the four mounting screws from the rear bearing block of the pedal support.
5. Remove the snap rings and washers from the pedal shafts.



TO REDUCE THE RISK OF EYE INJURY, WEAR EYE PROTECTION WHEN REMOVING SNAP RINGS.

## PARTS REMOVAL AND REPLACEMENT

6. Slide the pedal assembly off the pedal shafts and remove the remaining washers.
7. Install the new pedal assembly in reverse order.

### PEDAL RETURN SPRINGS

1. Remove the appropriate side cover.
2. Reach between the alternator and the main frame (left side only) to pull up on the spring and remove it from the spring hanger.

***Note: If you are having difficulty removing the left spring, remove the power control board for more accessibility.***

3. Detach the spring from the step chain by removing the single pitch master link.
4. Reinstall the spring and verify that it is seated in the spring hanger groove.



## WARNING

DO NOT TWIST THE SPRING DURING INSTALLATION. IT WILL WEAR EXCESSIVELY AND REDUCE THE LIFE OF THE SPRING.

### POWER CONTROL BOARD

1. Remove the left side cover.
2. Unplug the lower brake cable, alternator cable, lower main cable, stride sensor cable, load resistor cable, brake motor cable, and power connector from the power control board (see Figure 30).
3. Remove the two mounting screws from the board, and set the board aside.

## PARTS REMOVAL AND REPLACEMENT

4. Apply a thin coat of heat sink grease on the aluminum block of the new power control board, and attach the board to the frame.
5. Reconnect all the cables, and reinstall the side cover.

### PULLEYS

#### Idler Pulley Assembly

1. Remove the side cover.
2. Disconnect the idler spring from the frame.
3. Remove the snap ring from the idler pulley assembly mount and remove the assembly from the frame.



### WARNING

TO REDUCE THE RISK OF EYE INJURY, WEAR EYE PROTECTION WHEN REMOVING SNAP RINGS.

4. Remove the snap ring from the pulley, and slide the bearings off the shaft.
5. Install the new bearings on the idler pulley bracket.
6. Reassemble the idler pulley assembly on the frame, and ensure that the lower Poly-V belt aligns with the idler pulley. Reinstall the side cover.

#### Intermediate Poly-V Pulley Assembly

1. Remove the left side cover.
2. Remove the upper and lower Poly-V belts.
3. Remove the mounting bolt and washer from the pulley, freeing the assembly from the frame.

## PARTS REMOVAL AND REPLACEMENT

4. Install the new pulley assembly, and install the belts.
5. Install the upper Poly-V belt and pivot the alternator up or down as necessary to allow  $\frac{1}{4}$ " of deflection at the midpoint between the two pulleys (see Figure 20).
6. Reinstall the side cover.

### Lower Poly-V Pulley

1. Remove the left side cover.
2. Remove the lower Poly-V belt.
3. Remove the snap ring and washers from the drive shaft, loosen the two lower pulley set screws and slide the pulley off the shaft.



TO REDUCE THE RISK OF EYE INJURY, WEAR EYE PROTECTION WHEN REMOVING SNAP RINGS.

4. Verify that the drive shaft key is fully inserted into the key way when installing the new pulley.

### REAR SUPPORT BAR

1. Remove the safety panel.
2. Remove the step cover.
3. Have an assistant help you tilt the machine forward onto the console handlebar.
4. Remove the step.
5. Remove the mounting bolts and washers from the rear support bar



## PARTS REMOVAL AND REPLACEMENT

and remove the rear support bar from the frame.

6. Install the new rear support bar, and have an assistant help you tilt the machine back into place.
7. Reassemble the machine in reverse order.

### STEP

1. Remove the two bolts and washers from each end of the step.
2. Remove the step.
3. Reattach the step in reverse order.

### STRIDE SENSOR

1. Remove the left side cover.
2. Unplug the stride sensor from the power control board and remove the mounting screw from the stride sensor board.
3. Install the new board, ensuring that the leg sprocket magnet is aligned between the two drilled holes in the stride sensor board. The distance between the leg sprocket magnet and the board should be approximately .25 - .30 inches.

### SPRING CARTRIDGE

1. Remove the covers.
2. Prop the rear of the pedals up and remove both lower heel link chains from the spring cartridge.
3. Have an assistant help you tilt the machine forward, resting the console handlebar on the floor.
4. Loosen and remove the spring cartridge mounting bolts from the frame. Remove the spring cartridge.

## PARTS REMOVAL AND REPLACEMENT



THE SPRING CARTRIDGE IS UNDER HIGH PRESSURE. DO NOT OPEN THE SPRING CARTRIDGE.

5. Install the new spring cartridge, connect the lower heel link chains and have an assistant help you tilt the machine back into place.
6. Tension the heel link turnbuckles and adjust the top edge of the heel link pivot assembly so that it is parallel with the floor (see Figure 27).
7. Reinstall the covers.

### SPROCKETS

#### Drive Chain Idler Sprockets and Heel Link Idler Sprockets

1. Remove all of the covers.
2. Remove the drive chain assemblies from the drive chain sprockets.
3. Remove the drive shaft assembly.
4. Remove the heel link chains from the heel link sprockets.
5. Remove the mounting blocks.
6. Remove the idler mounting bolts and install the new sprocket(s).
7. Reassemble the machine in reverse order, and adjust the top edge of the heel link pivot assembly so that it is parallel with the floor (see Figure 27).

#### Drive Sprocket

1. Remove the appropriate side cover.

## PARTS REMOVAL AND REPLACEMENT

2. Remove the lower Poly-V belt, and remove the snap ring, washers, and lower Poly-V pulley from the drive shaft.



### WARNING

TO REDUCE THE RISK OF EYE INJURY, WEAR EYE PROTECTION WHEN REMOVING SNAP RINGS.

3. Remove the spring from the spring hanger, and disengage the pedal arm spring chain from the sprocket.
4. Remove the snap ring and washers from the drive shaft (right side only).



### WARNING

TO REDUCE THE RISK OF EYE INJURY, WEAR EYE PROTECTION WHEN REMOVING SNAP RINGS.

5. Rotate the sprocket off the drive shaft.
6. Install the right sprocket with the teeth facing the mounting block and the left sprocket with the teeth facing the side cover (see Figure 21).
7. Reattach the spring and verify that it is seated in the spring hanger groove. Reinstall the side cover.

### Upper Heel Link Idler Sprockets

1. Remove the appropriate pedal, side cover, and safety panel.
2. Remove the power control board (left side only).
3. Loosen the heel link turnbuckle (see Figures 17 and 18), and remove the heel link flange bearing.





## **PARTS REMOVAL AND REPLACEMENT**

4. Unhook the extension spring from the spring hanger.
5. Remove the jam nut and washer from the heel link assembly shaft.
6. Support the sprocket with chains attached, and remove the heel link assembly from the bearing block.
7. Lower the sprocket and remove the upper heel link chains from the sprocket.
8. Install the new sprocket and reassemble the machine in reverse order. Adjust the top edge of the heel link pivot assembly so that it is parallel with the floor (see Figure 27).

## **TURNBUCKLE ASSEMBLY ADJUSTMENTS**

1. Remove the side cover and loosen the turnbuckle jam nut.
2. Rotate the center link to the desired tension, and tighten the jam nut.

## GROUNDING INSTRUCTIONS

This equipment must be grounded. If it should malfunction or breakdown, grounding provides a path of least resistance for electric current to reduce the risk of electric shock. This equipment has a cord having an equipment-grounding conductor and a grounding plug. The plug must be plugged into an appropriate outlet that is properly installed and grounded in accordance with all local codes and ordinances.



IMPROPER CONNECTION OF THE EQUIPMENT-GROUNDING CONDUCTOR CAN RESULT IN THE RISK OF ELECTRIC SHOCK. CHECK WITH A QUALIFIED ELECTRICIAN OR SERVICE PERSON IF YOU ARE IN DOUBT AS TO WHETHER THE EQUIPMENT IS PROPERLY GROUNDED. DO NOT MODIFY THE PLUG PROVIDED WITH THIS EQUIPMENT — IF IT WILL NOT FIT THE AVAILABLE OUTLET, HAVE A PROPER OUTLET INSTALLED BY A QUALIFIED ELECTRICIAN.

This equipment is for use on a nominal 120-volt circuit, and has a grounding plug that looks like the plug illustrated in sketch A in Figure 17. A temporary adapter that looks like the adapter illustrated in sketches B and C may be used to connect this plug to a temporary 2-prong receptacle as shown in sketch B if a properly grounded outlet (sketch A) is not available. The temporary adapter should only be used until a properly grounded outlet can be installed by a qualified electrician. The green colored rigid ear, lug, or the like extending from the adapter must be connected to a permanent ground such as a properly grounded outlet box cover. Whenever the adapter is used, it must be held in place by a metal screw.

\* This may vary for International power supplies.

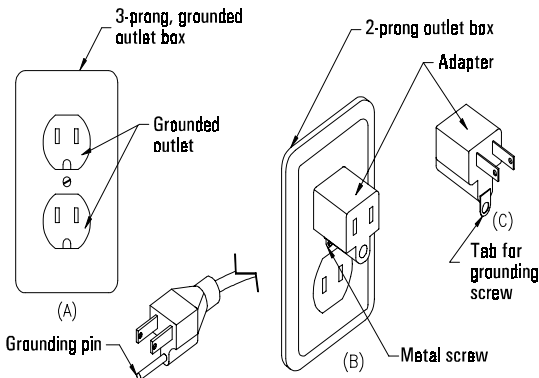

Figure 16: Grounding System

## FCC COMPLIANCE

This equipment has been tested and found to comply with the limits for a Class B digital device, pursuant to Part 15 of the FCC rules. These limits are designed to provide reasonable protection against harmful interference in a residential installation. This equipment generates, uses, and can radiate radio frequency energy and, if not installed and used in accordance with the instructions, may cause harmful interference to radio communications. However, there is no guarantee that interference will not occur in a particular installation. If this equipment does cause harmful interference to radio or television reception, which can be determined by turning the equipment off and on, the user is encouraged to try to correct the interference by one or more of the following measures:

- Reorient or relocate the receiving antenna.
- Increase the separation between the equipment and receiver.
- Connect the equipment to an outlet on a circuit different from that to which the receiver is connected.
- Consult the dealer or an experienced radio/TV technician for help.



### **WARNING**

CHANGES OR MODIFICATIONS TO EQUIPMENT NOT EXPRESSLY APPROVED BY STAIRMASTER® HEALTH & FITNESS PRODUCTS, INC. COULD VOID THE USER'S AUTHORITY TO OPERATE THIS EQUIPMENT.

## CANADIAN DOC CLASS B COMPLIANCE

This digital apparatus does not exceed the Class B limits for radio emissions from digital apparatus set out in the radio interference regulations of the Canadian Department of Communications.

---

La présent appareil numérique ne dépasse pas les limites établies pour les bruits radioélectriques applicables aux appareils numériques de la Class B prescrites dans les règlement sur le brouillage radioélectrique édicté par le Ministère des Communications du Canada.

**IMPORTANT PHONE NUMBERS**

If you need assistance, please have both the serial number of your machine and the date of purchase available when you contact the appropriate StairMaster® Health & Fitness Products, Inc. office listed below.

**CORPORATE HEADQUARTERS**

12421 Willows Road NE #100  
Kirkland, WA 98034  
(800) 635-2936 or (425) 823-1825  
FAX: (425) 823-9490  
www.stairmaster.com

**CUSTOMER SERVICE**

12421 Willows Road NE #100  
Kirkland, WA 98034  
(800) 331-3578  
FAX: (425) 814-0601  
E-mail: customerservice@  
stairmaster.com

**INTERNATIONAL OFFICES AND DISTRIBUTORS****INTERNATIONAL DIVISION**

(425) 823-1825  
FAX: (425) 820-7505  
E-Mail: intlservice@stairmaster.com

**ASIA PACIFIC HEADQUARTERS**

Telephone/Fax: +81-45-590-5686  
E-mail: stairintl@aol.com

**EUROPE: HEADQUARTERS**

+41-91-827-3801  
FAX: +41-91-827-3802  
E-Mail: stairmasterch@swissonline.ch

**GERMANY: HEADQUARTERS**

+49-2204/610-27  
FAX: +49-2204/628-90  
E-Mail: stairmaster.de@t-online.de

**U.K.: HEADQUARTERS**

+44-1908/267-345  
FAX: 44-1908/267-346  
E-mail: stairmasteruk@msn.com

# APPENDIX

## Figure 17: Final Assembly - Left Side

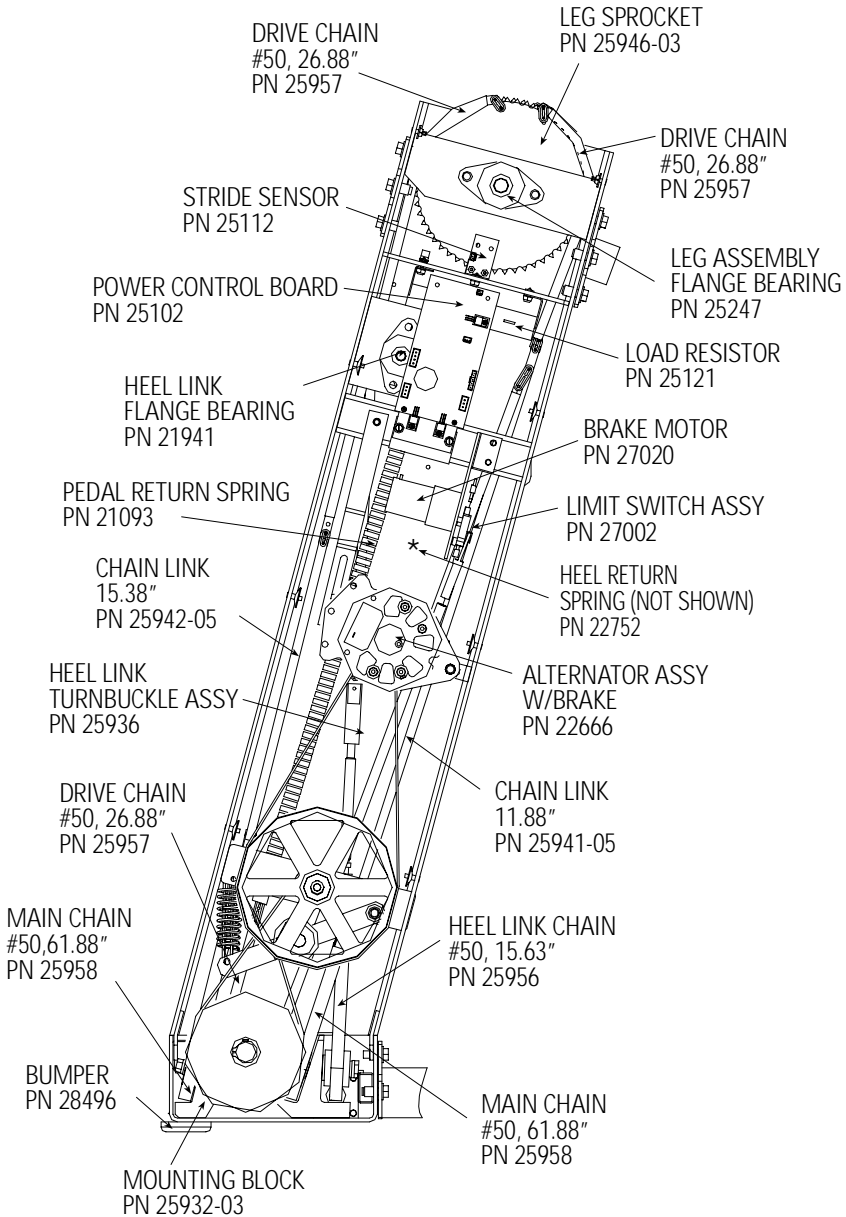
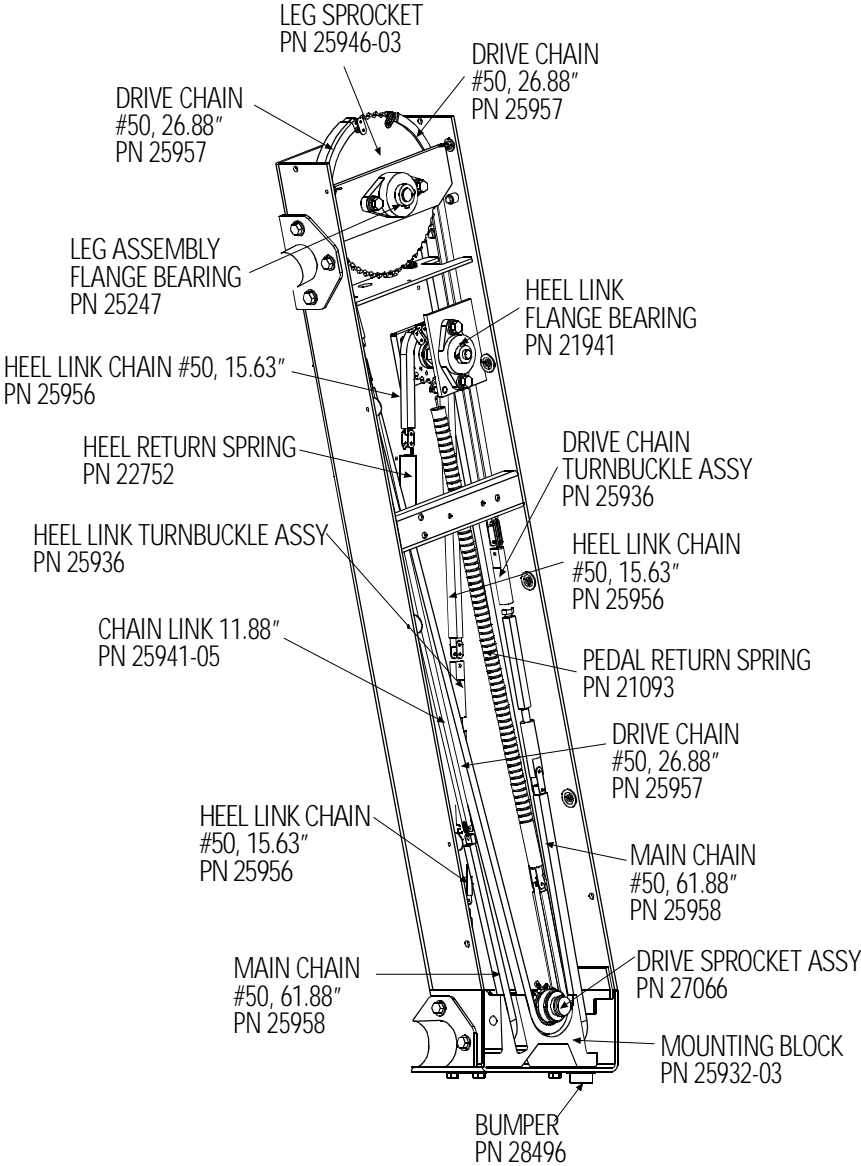

Figure 18: Final Assembly - Right Side



# APPENDIX

## Figure 19: Chain Assemblies

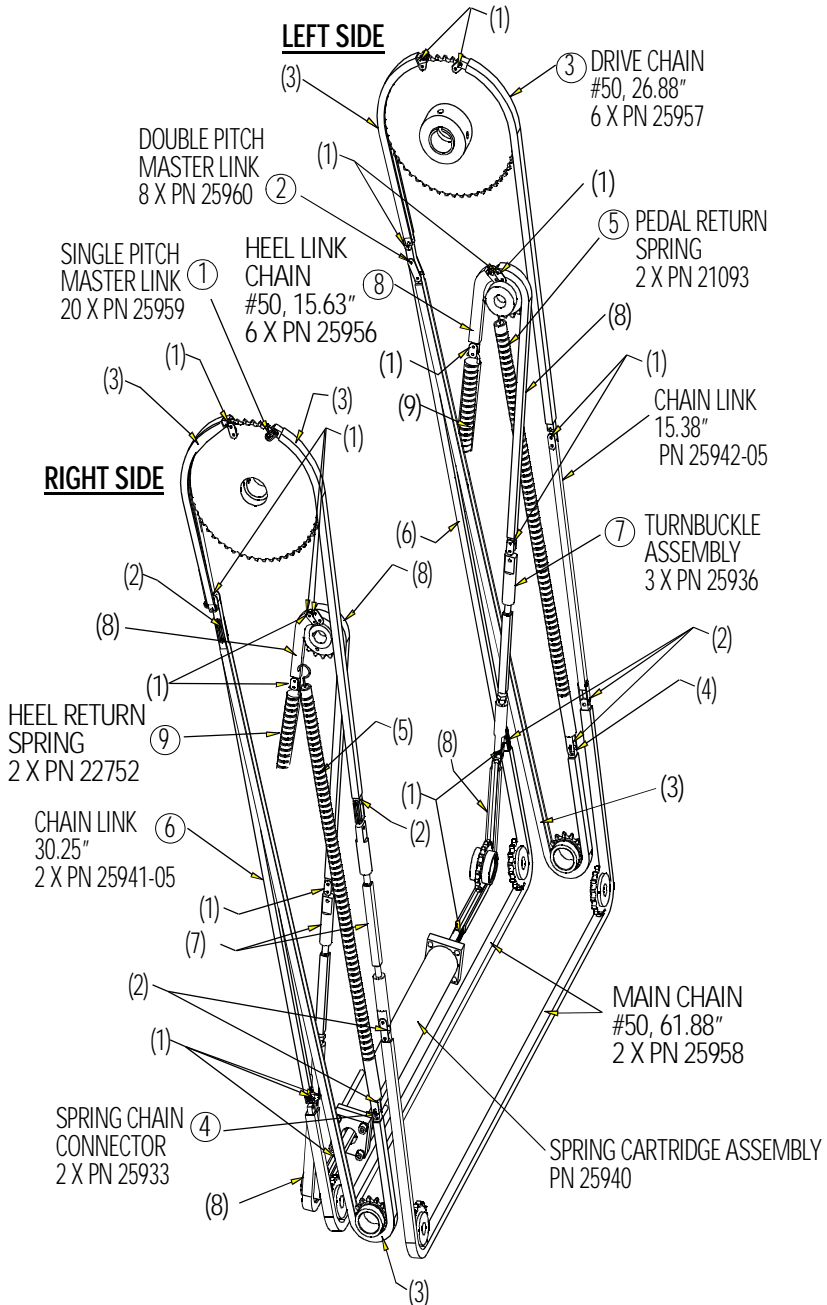

Figure 20: Belt Tension

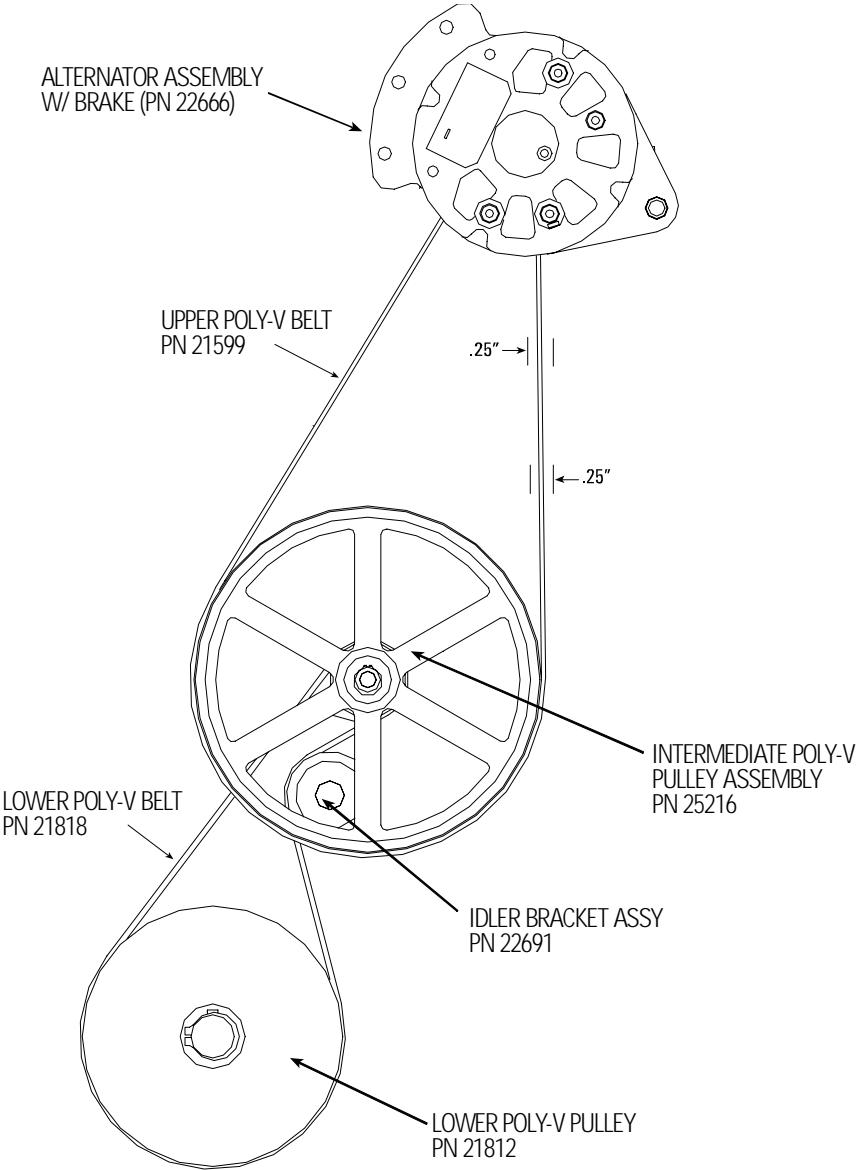



Figure 21: Drive Shaft Assembly

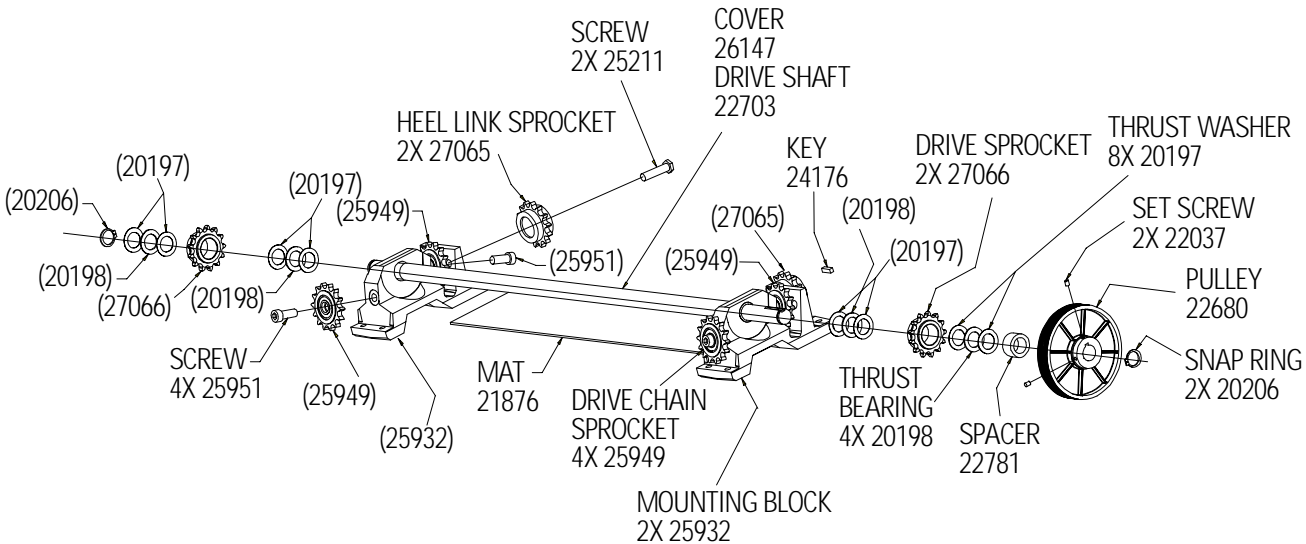
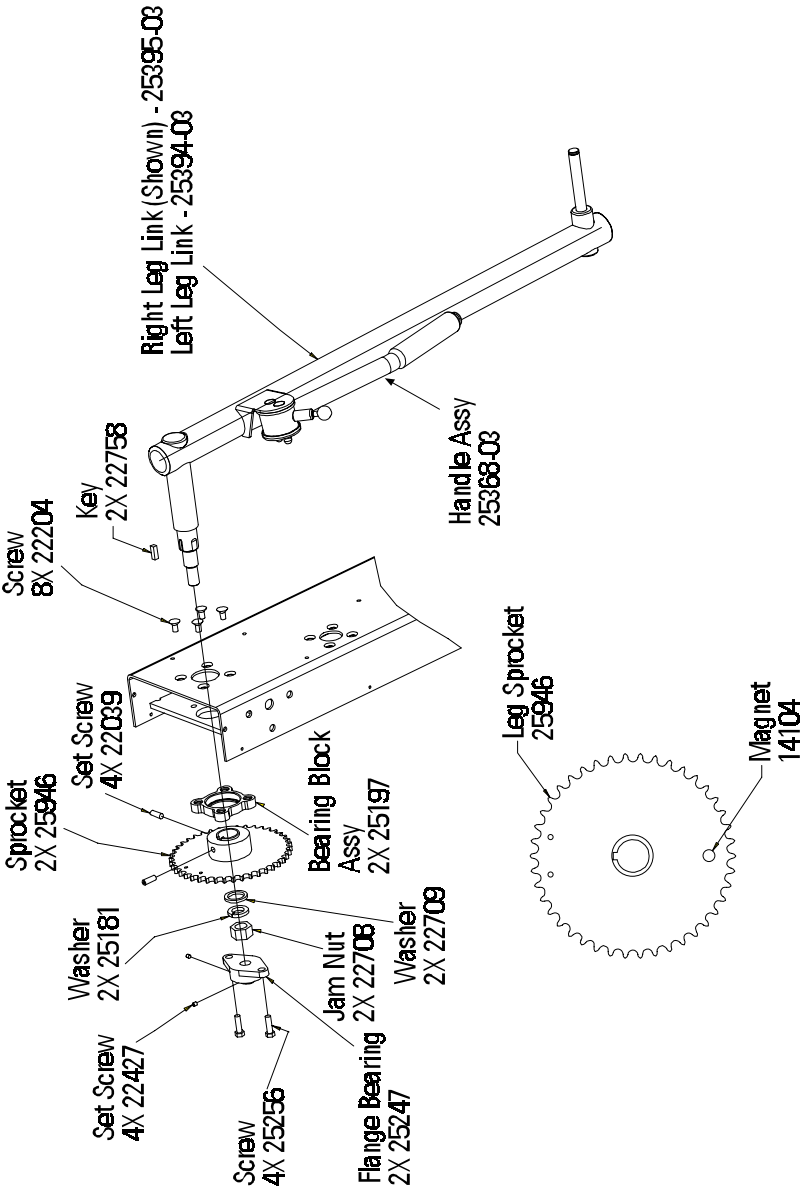
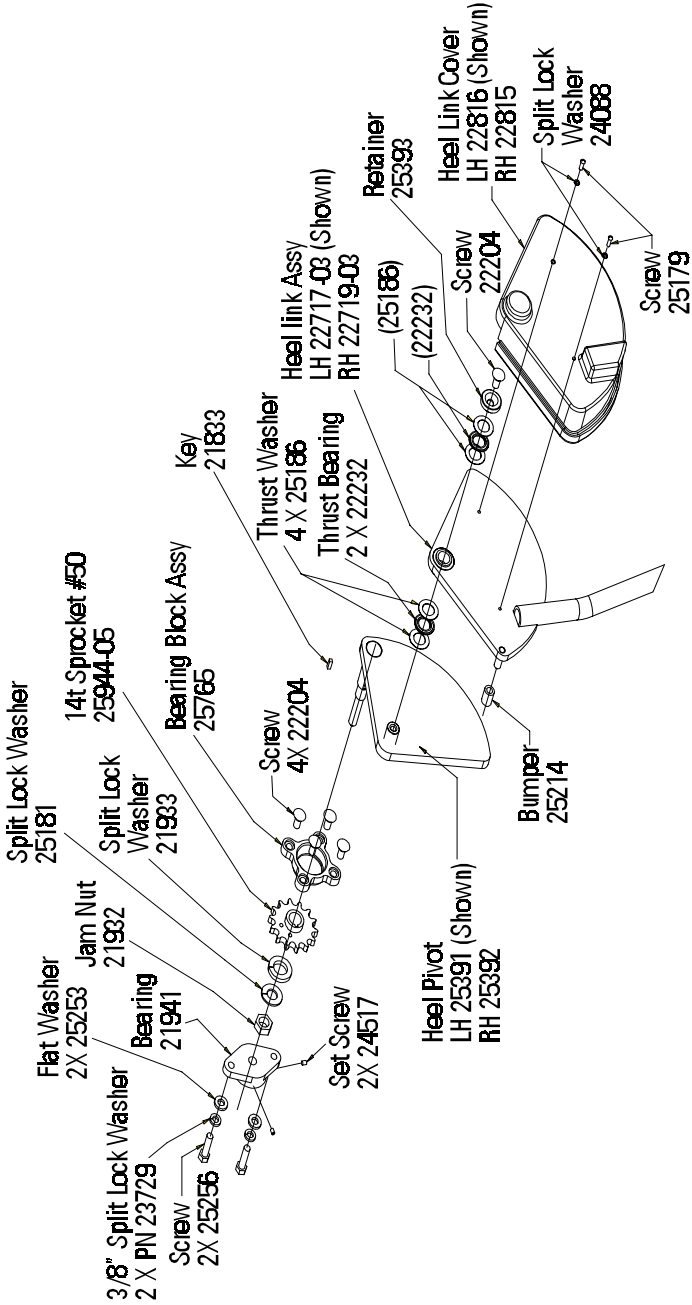

Figure 22: Leg Assembly



# APPENDIX

Figure 23: Heel Link Assembly



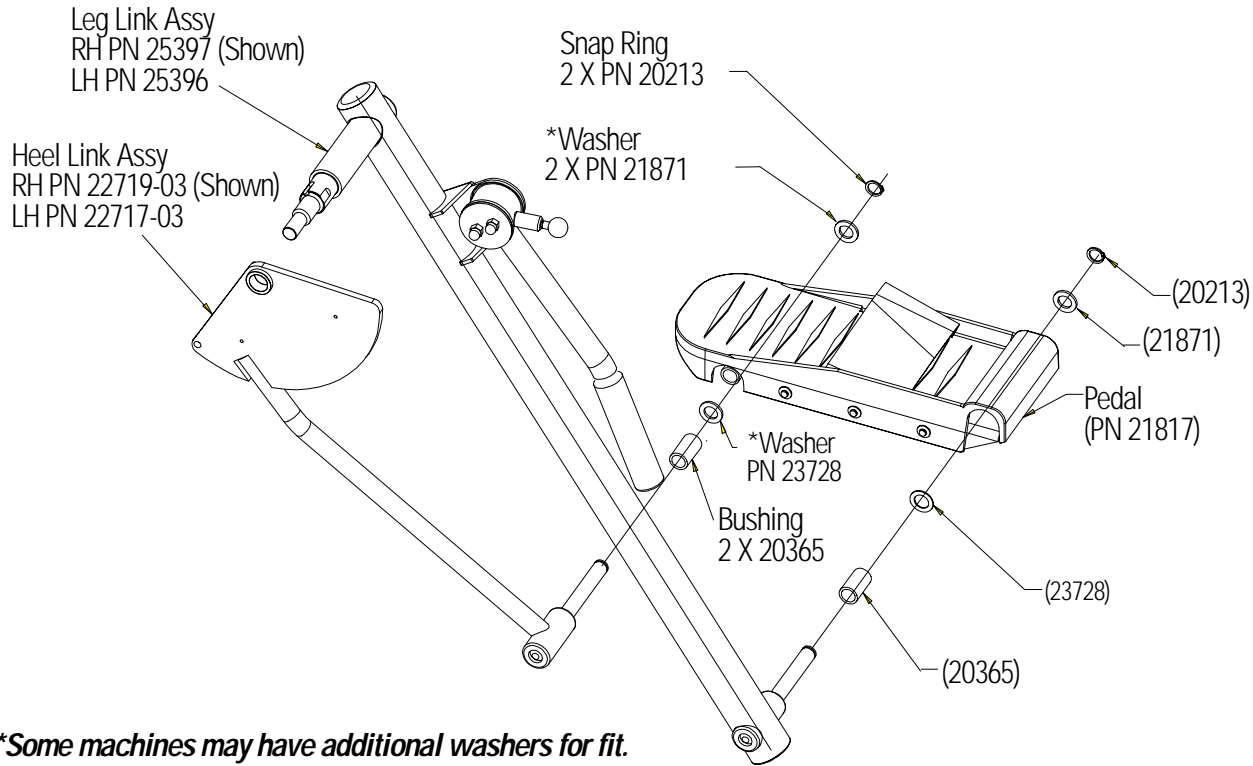

*\*Some machines may have additional washers for fit.*

Figure 24: Pedal Mounting

# APPENDIX

## Figure 25: Pedal Assembly

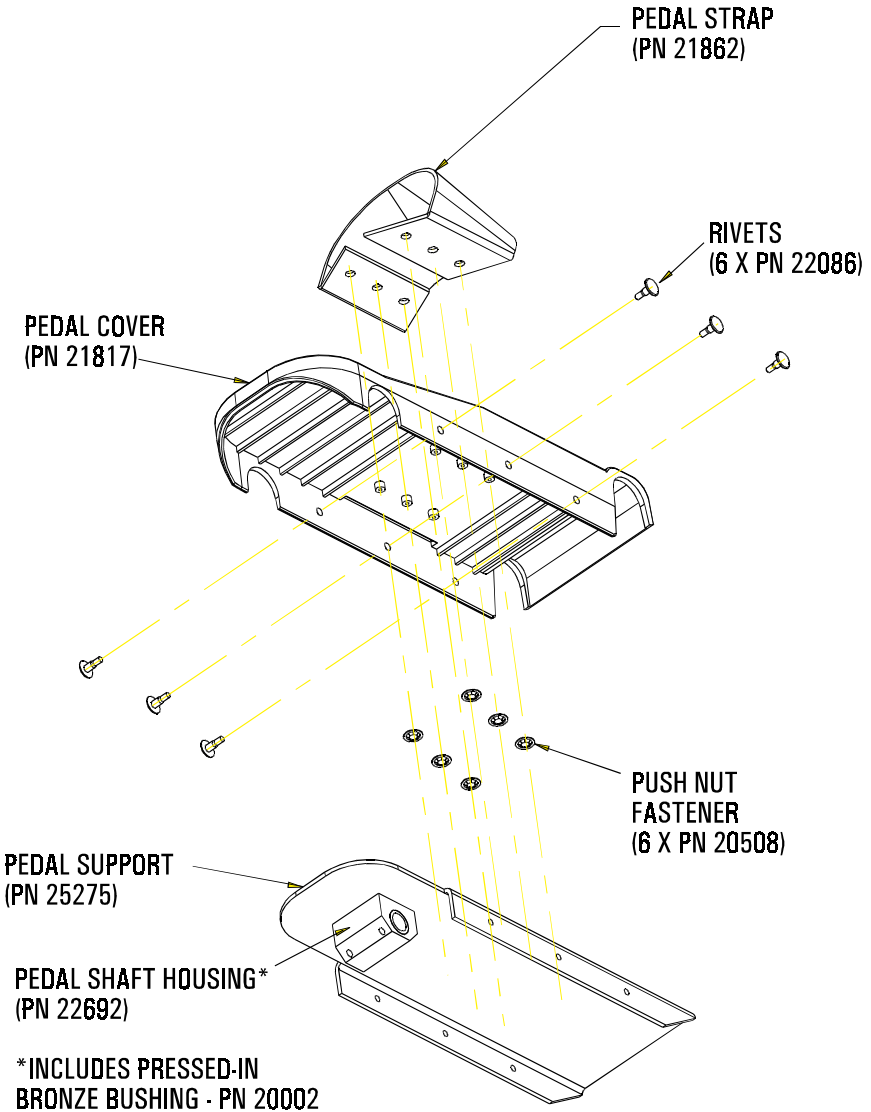
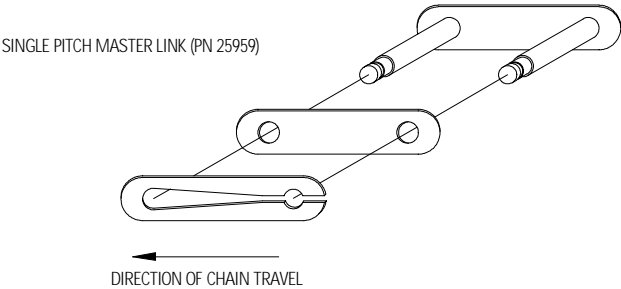
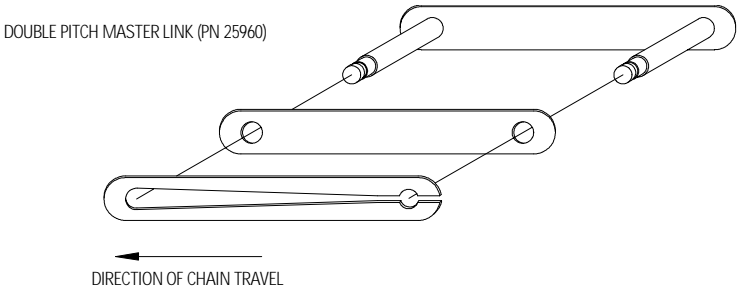

Figure 26: Master Links



# APPENDIX

## Figure 27: Heel Link Pivot Adjustment

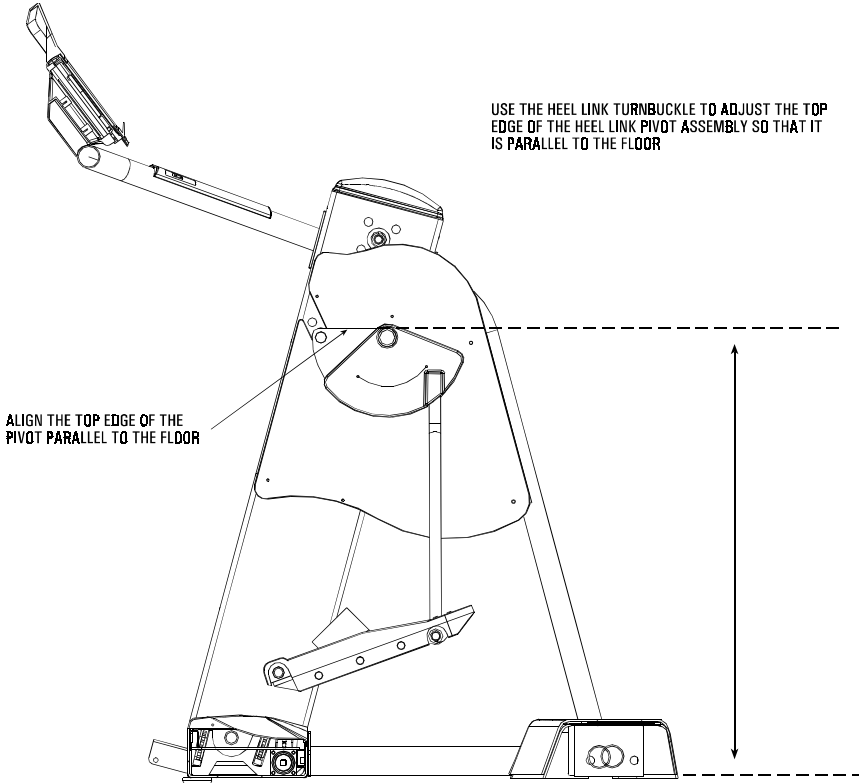
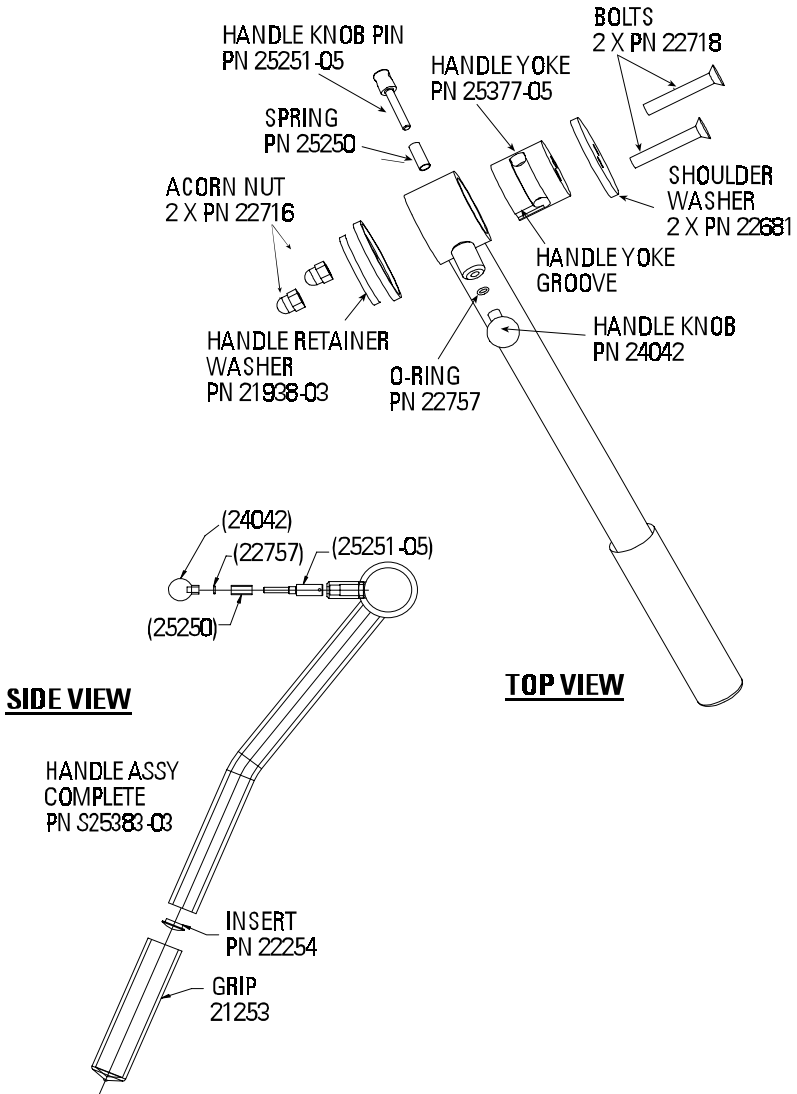

Figure 28: Handle Assembly





# APPENDIX

## Figure 29: Limit Switch Assembly

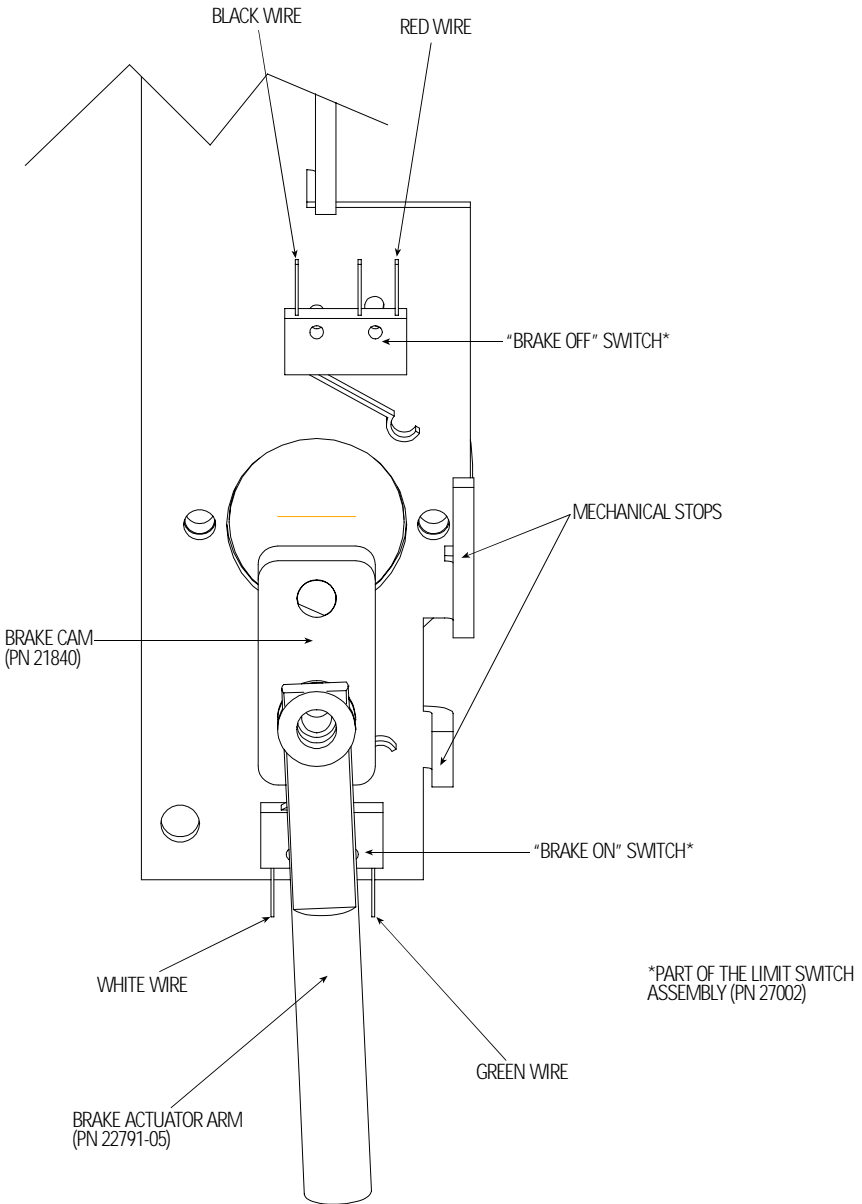
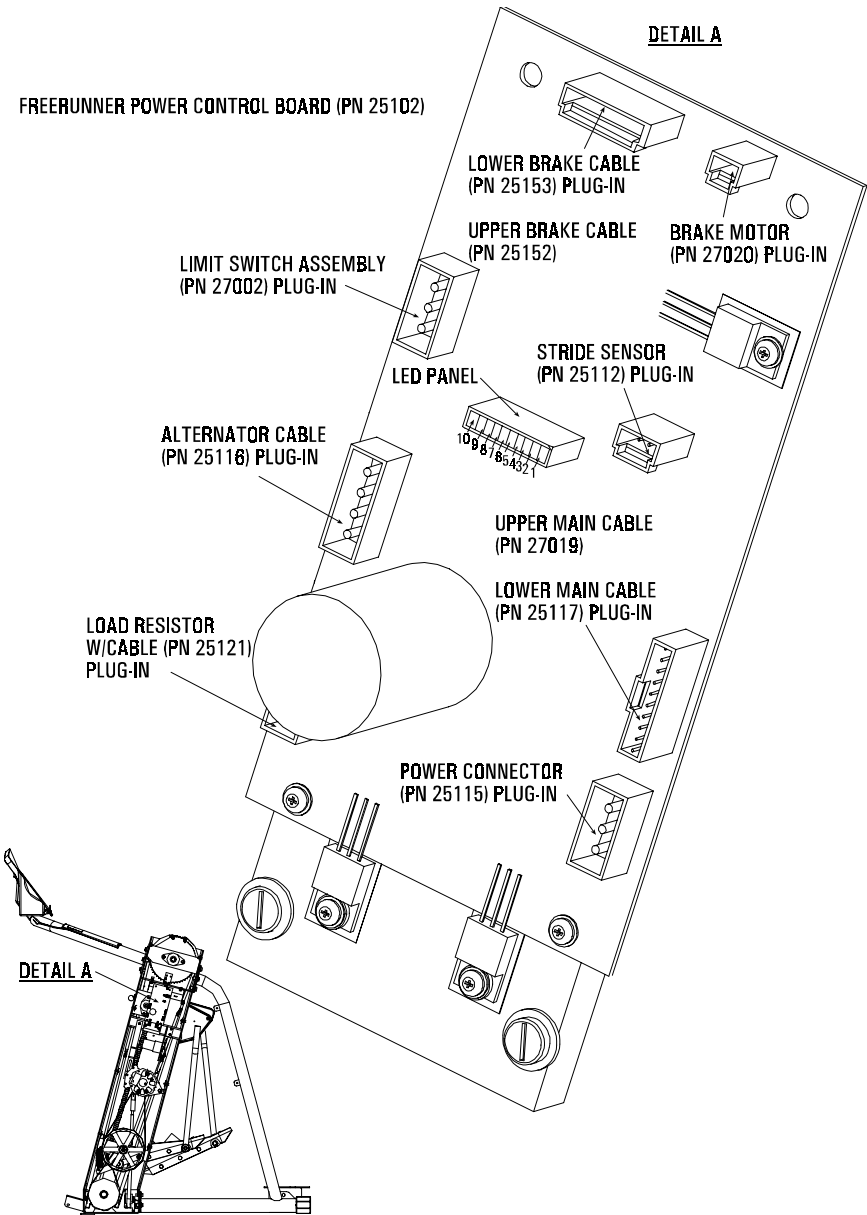
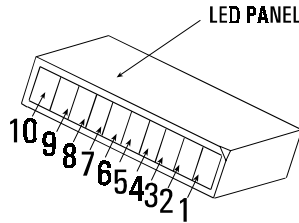

Figure 30: Power Control Board "A"



# APPENDIX

## Figure 31: LED Panel



### POWER CONTROL BOARD - LIGHT EMITTING DIODES (LEDs)

- #1 - **V Supply** - Indicates that there is power from the power supply.
- #2 - **VCC** - Indicates that 5VDC is supplied from the console.
- #3 - **Alt Off** - Remains illuminated, until workout program is executed. LED will then turn OFF indicating that the alternator field is being engaged.
- #4 - **Load Resistor** - Remains illuminated when the console is in the ATTRACT mode. The LED fades out as intensity level increases during an exercise program.
- #5 - **Stride Sensor** - Illuminates when pedals are aligned. Will turn ON and OFF as pedals are moved back and forth during an exercise program.
- #6 - **Motor Dir** - Remains illuminated. ONLY when the brake system is disengaged will the LED turn off.
- #7 - **Motor On** - LED will momentarily turn OFF every time the brake motor is activated.
- #8 - **"Brake On"** - Momentarily turns OFF when the brake cam is rotated to the lower limit switch to engage the brake system.
- #9 - **"Brake Off"** - Momentarily turns OFF when the brake cam is rotated to the upper limit switch to disengage the brake system.
- #10 - **Not Used** - This LED should never be on.

**\*\*\*AT REST, WITHOUT ANYONE ON THE MACHINE, NINE LEDS SHOULD BE ON\*\*\***

Figure 32: Power Control Board "B"

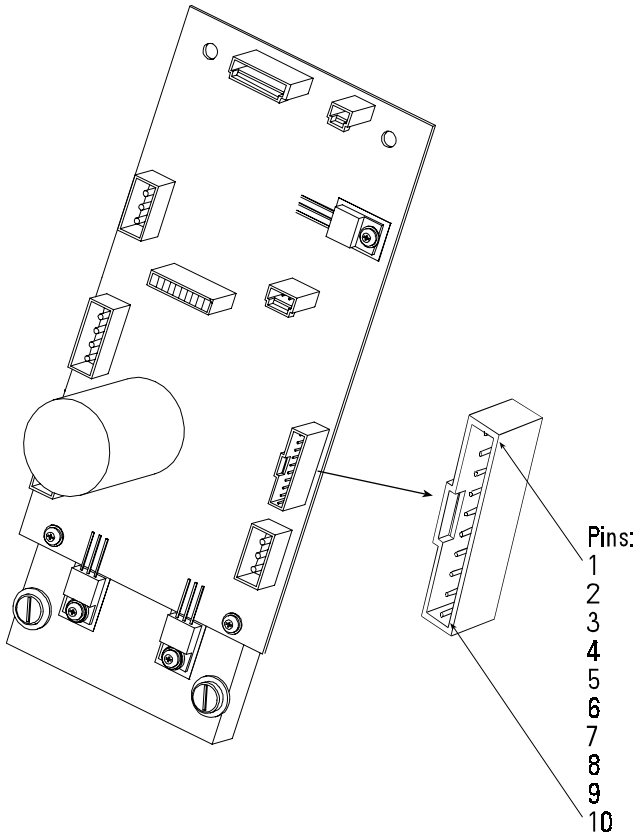

**CONSOLE PLUG-IN**  
**(On the PCB Board)**

- Pin 1 - Alt Off
- Pin 2 - V Supply
- Pin 3 - B+ Scaled
- Pin 4 - Resistor Control
- Pin 5 - VCC
- Pin 6 - N/C
- Pin 7 - Tach
- Pin 8 - N/C
- Pin 9 - Stride Sensor
- Pin 10 - Ground

Figure 33: Alternator Cable

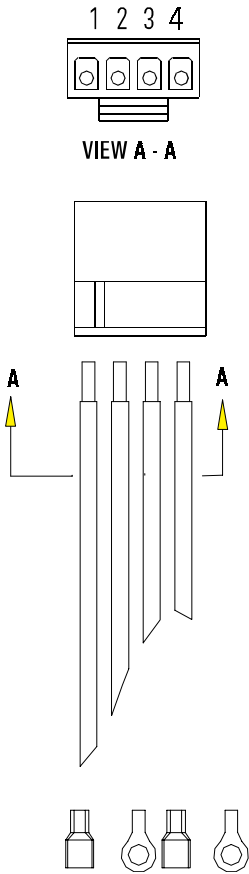

**ALTERNATOR CABLE**

- Pin 1 - B+ (White Wire)
- Pin 2 - Ground (Black Wire)
- Pin 3 - Field (Brown Wire)
- Pin 4 - Tach (Blue Wire)

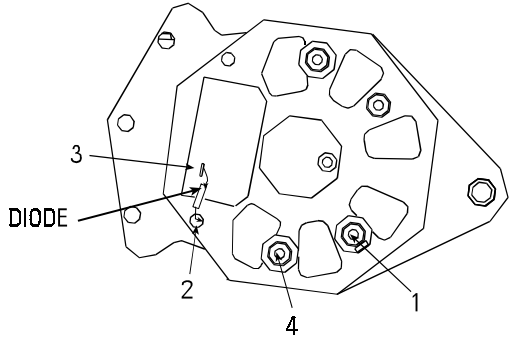
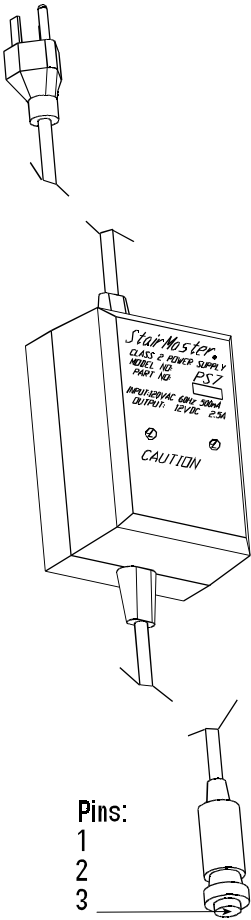

Figure 34: Power Supply



**POWER SUPPLY**

- Pin 1 - V Supply
- Pin 2 - Ground
- Pin 3 - Earth Ground

# APPENDIX

Figure 35: Load Resistor

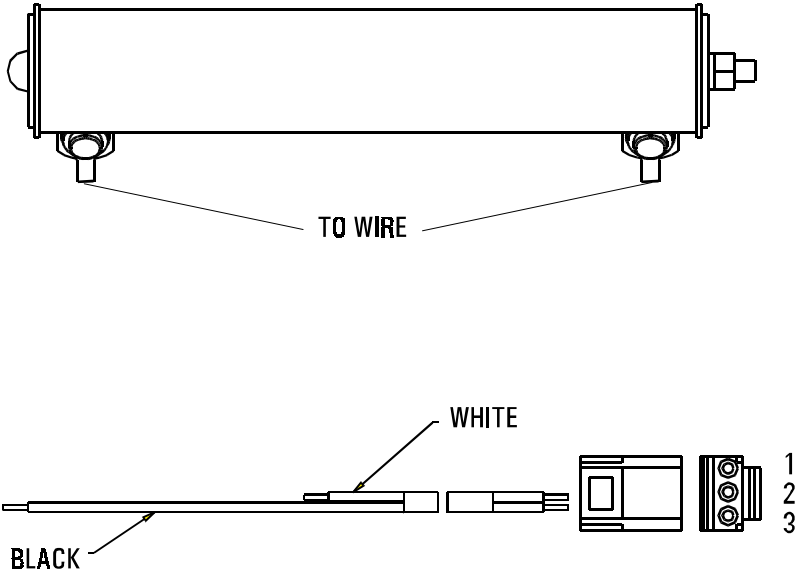

## **LOAD RESISTOR**

1/2 Ohm 240 Watt  
1/2 Ohm measured at Pins 1 and 3