

NordicTrack[®] *9800 Incline Trainer*

Model No. _____

Serial No. _____

The model number and serial number are found in the location shown below. Write the model number and serial number in the space above.

Serial Number Decal

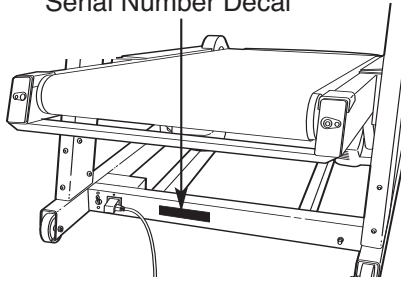

QUESTIONS?

At FreeMotion Fitness, Inc., we're committed to providing complete customer satisfaction. For assistance, please contact your distributor.

CAUTION

Read all precautions and instructions in this manual before using this equipment. Keep this manual for future reference.

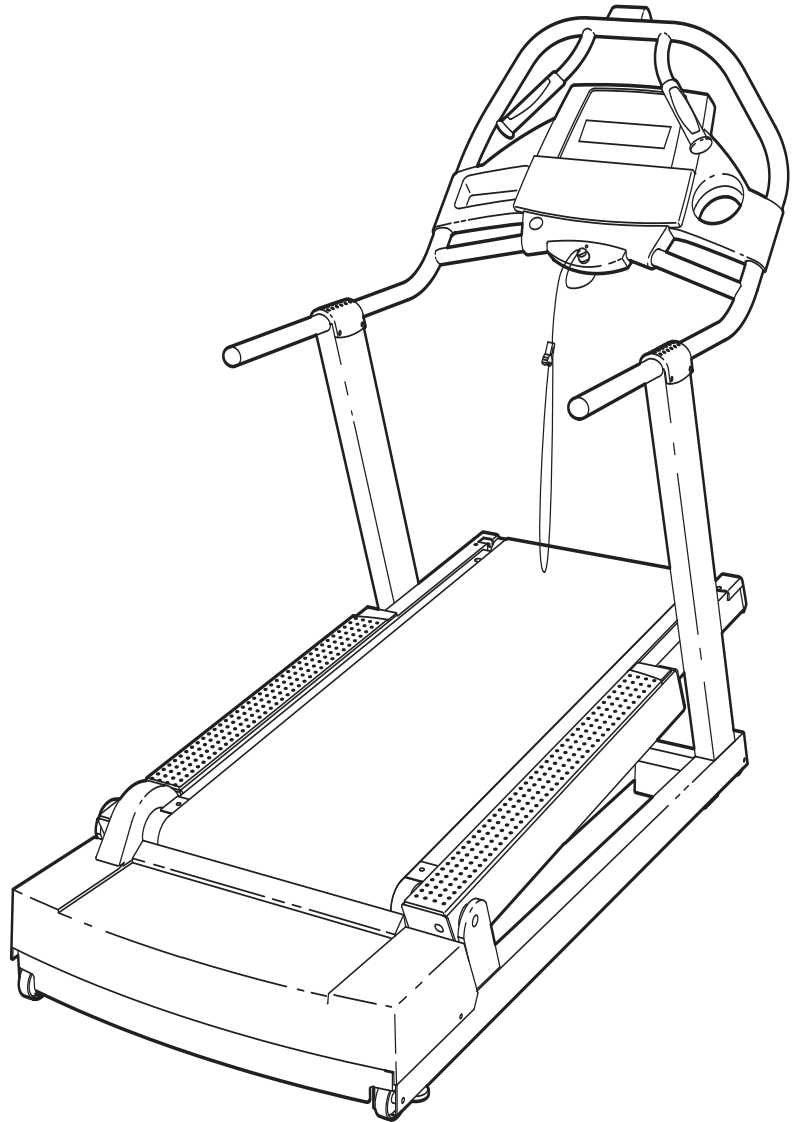

USER'S MANUAL



NordicTrack[®]

9800 Incline Trainer

TABLE OF CONTENTS

SECTION 1

Important Precautions	3
Warning Decal Placement	5
Before You Begin	6
How to Set Up the INCLINE TRAINER	7
How to Move the INCLINE TRAINER	9
How to Connect the INCLINE TRAINER	10
How to Upgrade your Console	11

SECTION 2

How to Use the Basic Console	13
How to Use the Workout TV Console	25

SECTION 3

Preventive Maintenance	27
Six-month Preventive Maintenance Record	29
Troubleshooting	31

SECTION 4

Exercise Guidelines	33
-------------------------------	----

SECTION 5

Part List	37
Exploded Drawing	39
How to Order Replacement Parts	42

IMPORTANT PRECAUTIONS

⚠ WARNING: To reduce the risk of burns, fire, electric shock, or injury to persons, read the following important precautions and information before operating the INCLINE TRAINER.

1. It is the responsibility of the owner to ensure that all users of the INCLINE TRAINER are adequately informed of all warnings and precautions.
2. Use the INCLINE TRAINER only as described in this manual.
3. Place the INCLINE TRAINER on a level surface, with at least eight feet of clearance behind it. Do not place the INCLINE TRAINER on any surface that blocks air openings. To protect the floor or carpet from damage, place a mat under the INCLINE TRAINER.
4. Keep the INCLINE TRAINER indoors, away from moisture and dust. Do not place the INCLINE TRAINER in a garage or covered patio, or near water.
5. Do not operate the INCLINE TRAINER where aerosol products are used or where oxygen is being administered.
6. Do not operate the INCLINE TRAINER until it is properly assembled (see HOW TO SET UP THE INCLINE TRAINER on page 7).
7. Regularly inspect and tighten all parts of the INCLINE TRAINER.
8. Keep children under the age of 12 and pets away from the INCLINE TRAINER at all times.
9. The INCLINE TRAINER should not be used by persons weighing more than 160 kg (350 lbs.).
10. Never allow more than one person on the INCLINE TRAINER at a time.
11. Wear appropriate exercise clothes when using the INCLINE TRAINER. Do not wear loose clothes that could become caught in the INCLINE TRAINER. Athletic support clothes are recommended for both men and women. *Always wear athletic shoes. Never use the INCLINE TRAINER with bare feet, wearing only stockings, or in sandals.*
12. When connecting the power cord (see page 10), plug the power cord into a grounded circuit capable of carrying 10 or more amps. No other appliance should be on the same circuit. Do not use an extension cord.
13. Keep the power cord away from heated surfaces.
14. Never move the walking belt whilst the power is turned off. Do not operate the INCLINE TRAINER if the power cord or plug is damaged or if the INCLINE TRAINER is not working properly. (See BEFORE YOU BEGIN on page 6 if the INCLINE TRAINER is not working properly.)
15. Never start the INCLINE TRAINER whilst you are standing on the walking belt. Always hold the handrails whilst using the INCLINE TRAINER.
16. The INCLINE TRAINER is capable of high speeds. Adjust the speed in small increments to avoid sudden jumps in speed.
17. The pulse sensor is not a medical device. Various factors, including the user's movement, may affect the accuracy of heart rate readings. The pulse sensor is intended only as an exercise aid in determining heart rate trends in general.
18. Never leave the INCLINE TRAINER unattended whilst it is running. Always remove the key, unplug the power cord, and switch the on/off circuit breaker to the off position when the INCLINE TRAINER is not in use.
19. Do not change the incline of the INCLINE TRAINER by placing objects under it.
20. Never insert or drop any object into any opening.
21. Make sure to perform all maintenance procedures outlined in this manual. Failure to do so will void the warranty and may result in damage to the INCLINE TRAINER.

22. **DANGER:** Always unplug the power cord immediately after use, before cleaning the INCLINE TRAINER, and before performing the maintenance and adjustment procedures

described in this manual. Servicing other than the procedures in this manual should be performed by an authorized service representative only.

⚠ WARNING: Before beginning this or any exercise program, consult your physician. This is especially important for persons over the age of 35 or persons with pre-existing health problems. Read all instructions before using. ICON assumes no responsibility for personal injury or property damage sustained by or through the use of this product.

SAVE THESE INSTRUCTIONS

WARNING DECAL PLACEMENT

The decals shown below are found on the INCLINE TRAINER. If any decal is missing or illegible, please contact your distributor to order a free replacement decal. Apply the decal in the location shown.

⚠ WARNING: HIGH VOLTAGE!

Please do not attempt to service this unit without contacting distributor.

Note: This decal is shown at 75% of actual size.

⚠ CAUTION

KEEP HANDS AND FEET AWAY FROM THIS AREA WHILE THE TREADMILL IS IN OPERATION.

Note: This decal is shown at 80%.



Note: This decal is shown at 85%.

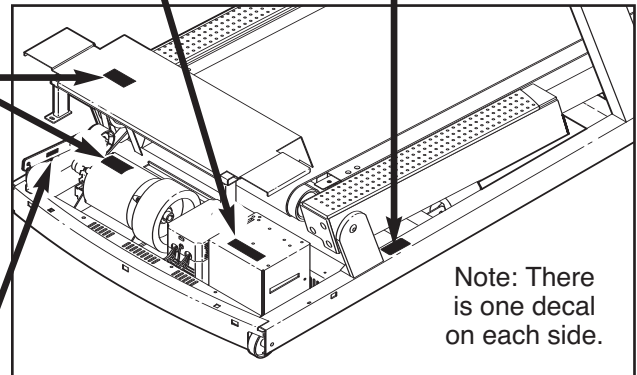

Note: There is one decal on each side.

⚠ CAUTION

Overtightening of J-bolt may result in severe motor damage. Refer to the service manual for proper tensioning procedure, or contact Customer Care.

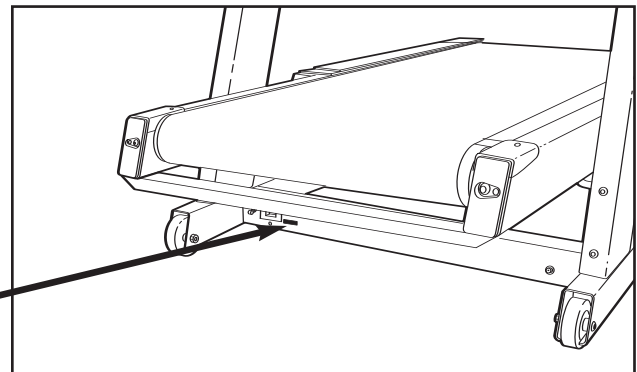

⚠ CAUTION: HIGH VOLTAGE Disconnect line cord from outlet before servicing.

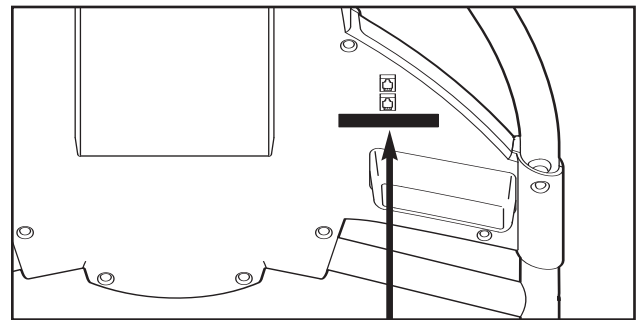

⚠ WARNING

Do not remove or insert this plug while the key is inserted in the console. Static sensitive components

⚠ WARNUNG

Dieser Stecker darf nicht entfernt oder eingesteckt werden während der Schlüssel im Computer eingesteckt ist. Statik empfindliche Komponente könnten beeinflusst werden.

⚠ ATTENZIONE

Non rimuovere o inserire questa presa mentre la chiave è inserita nella consolle. I componenti satico-sensibili potrebbero esserne compromessi.

⚠ AVERTISSEMENT

Ne retirez pas ou n'insérez pas la prise si la clé est insérée dans la consolle. Certaines des pièces électroniques peuvent être sensibles à la statique.

⚠ ADVERTENCIA

No quite o inserte este enchufe mientras que la llave esté insertada en la consola. Componentes sensibles a la estática pueden ser afectadas.

BEFORE YOU BEGIN

Congratulations for selecting the revolutionary NordicTrack® 9800 INCLINE TRAINER. The NordicTrack 9800 INCLINE TRAINER offers an impressive array of features to make your workouts more effective and enjoyable.

For your benefit, read this manual carefully before using the 9800 INCLINE TRAINER. If you have questions after reading the manual, please contact your distributor.

Before reading further, please familiarise yourself with the parts that are labeled in the drawing below.

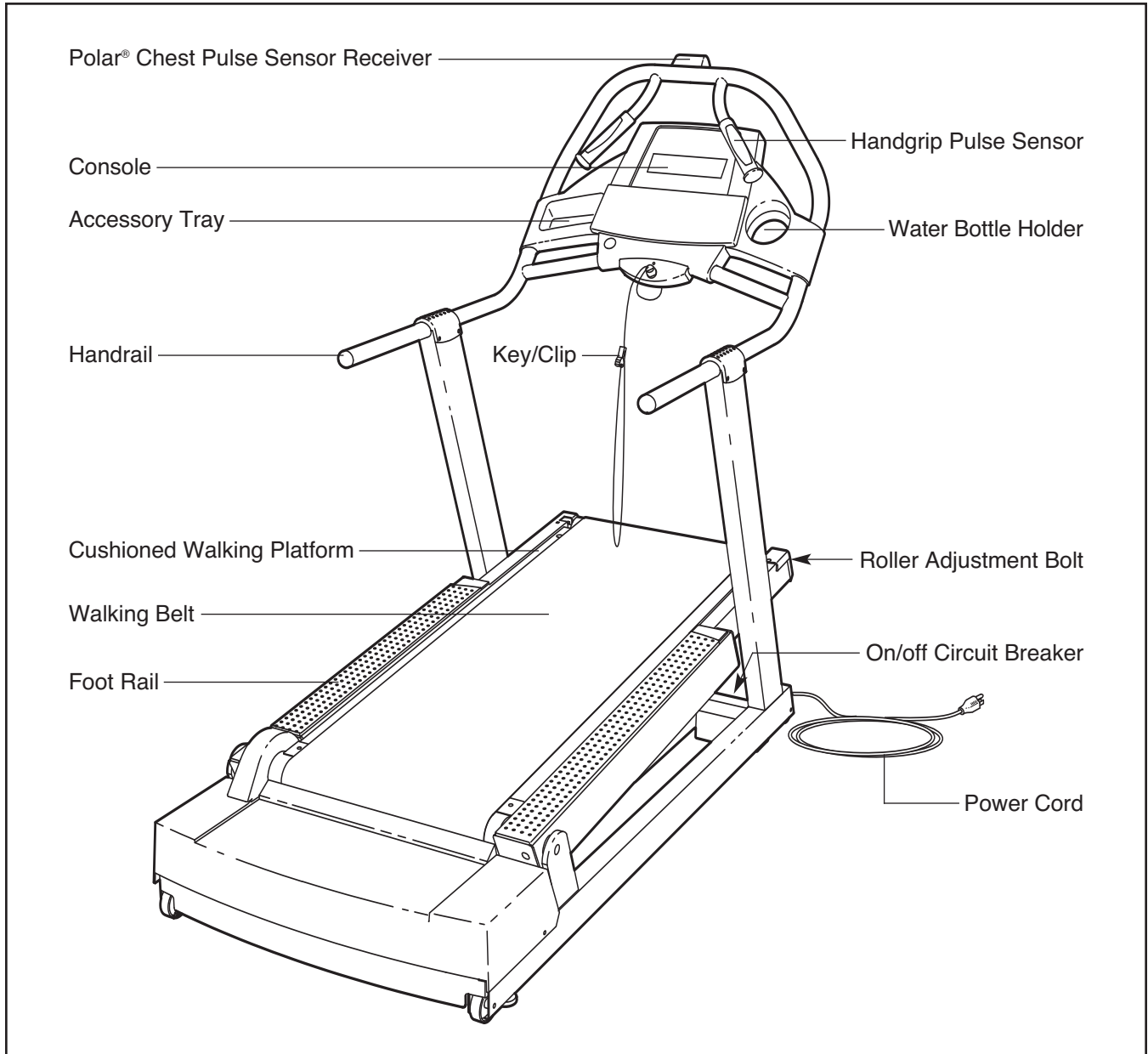

HOW TO SET UP THE INCLINE TRAINER

Assembly requires two persons. Set the INCLINE TRAINER in a cleared area and remove all packing materials. Do not dispose of the packing materials until assembly is completed. **Assembly can be completed using the included hex keys.**

Note: The underside of the INCLINE TRAINER walking belt is coated with high-performance lubricant. During shipping, a small amount of lubricant may be transferred to the top of the walking belt or the shipping carton. This is a normal condition and does not affect INCLINE TRAINER performance. If there is lubricant on top of the walking belt, simply wipe off the lubricant with a soft cloth and a mild, non-abrasive cleaner.

1. Slide the Right and Left Uprights (96, 107) onto the brackets near the front of the Base Frame (52). **Make sure that the Uprights are on the correct sides; the indicated holes must be facing the INCLINE TRAINER.**

Raise the Left Upright (107) until the lower hole in the front of the Left Upright is aligned with the upper hole in the bracket as shown. Thread an Upright Bolt (106) into the Left Upright and the bracket. **Do not fully tighten the Upright Bolt yet.**

Repeat this step with the Right Upright (96).

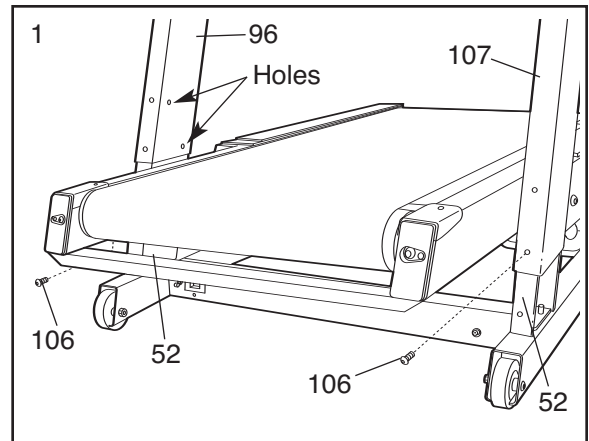

2. Whilst a second person holds the Handrail (94) near the Uprights (96, 107), feed the wires in both sides of the Handrail down into the Uprights. Pull the ends of the wires out of the lower ends of the Uprights and remove the wire ties from the ends of the wires.

Finger tighten four Handrail Bolts (93) into the Handrail (94) and the Uprights (96, 107) as shown. **Be careful to avoid pinching the wires in the Handrail.**

Note: The Accessory Holder (142) and the Cup Holder (10) are replaceable. If these parts become dislodged from the Console (89), press them back into place.

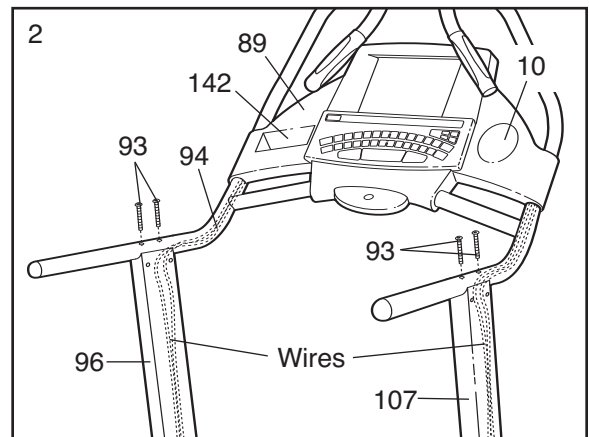

3. Connect the Right Upright Wire Harness (105), the TV Cable (33), and the Left Upright Wire Harness (131) in the indicated locations. **The connectors should slide together easily and snap into place.** If they do not, turn the connectors and try again. **IF THE CONNECTORS ARE NOT CONNECTED PROPERLY, THE CONSOLE MAY BE DAMAGED WHEN THE POWER IS TURNED ON.** Push all of the excess wire up into the Uprights (96, 107). **Make sure that all wires are fully connected.** **Note: Regardless of which console your INCLINE TRAINER has, connect all wires so that the console can later be upgraded if desired.**

See step 1. Whilst a second person holds the Uprights (96, 107), remove the Upright Bolts (106). Slide the Uprights fully onto the Base Frame (52). **Be careful to avoid pinching your hands or the wires.**

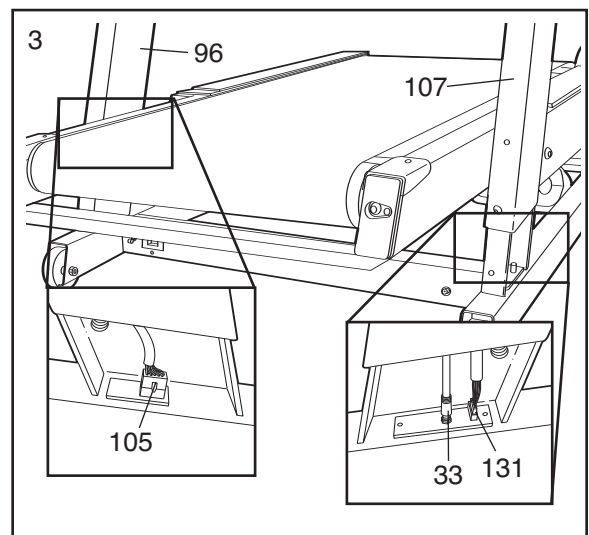

- Thread two Upright Bolts (106) into each Upright (96, 107) in the indicated locations. **Do not tighten the Upright Bolts yet.**

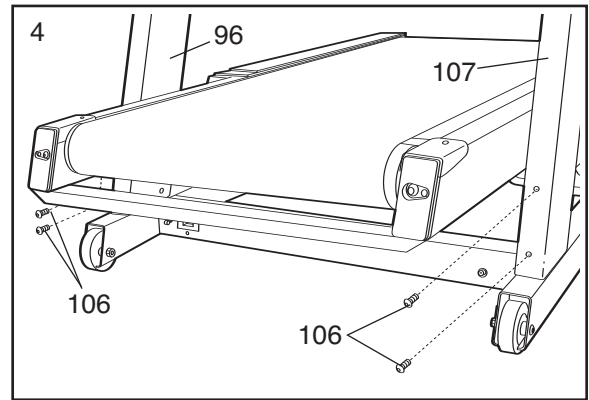

- Next it will be necessary to adjust the incline of the INCLINE TRAINER. First, plug in the power cord (see page 10). Next, make sure that the on/off circuit breaker is in the on position (see step 2 on page 14).

Place the Key (90) in the Console (89). Press the QUICK INCLINE button labeled “21” to adjust the incline to 21%. Then, remove the Key.

Move the on/off circuit breaker to the off position and unplug the power cord.

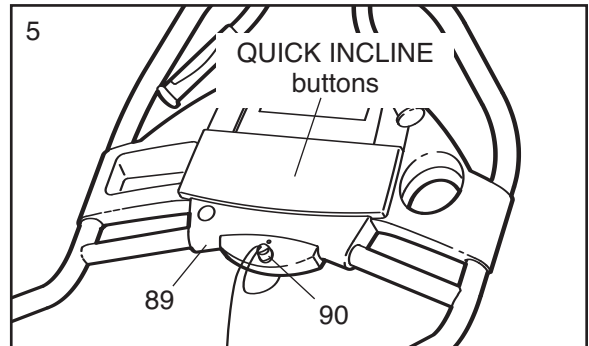

- Thread two additional Upright Bolts (106) into each Upright (96, 107) in the indicated locations. **Tighten all eight Upright Bolts in the Uprights.**

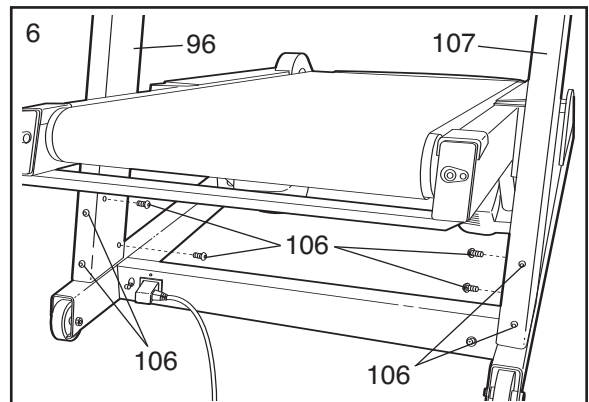

- See step 2 on page 7 and tighten the four Handrail Bolts (93).

Place the Upright Caps (92) over the Handrail (94) and the upper ends of the Uprights (96, 107). Press the Handrail Caps against the hook-and-loop fastener strips on the Uprights. Attach each Handrail Cap with four Upright Cap Screws (91). **Do not overtighten the Upright Cap Screws.**

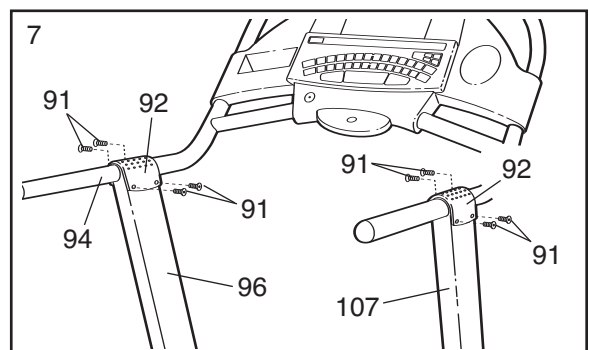

8. After the INCLINE TRAINER is placed in the location where it will be used (see HOW TO MOVE THE INCLINE TRAINER below), make sure that both Rear Feet (66) and both front Wheels (not shown) rest firmly on the floor. If the INCLINE TRAINER rocks even slightly, turn the right Rear Foot clockwise or counter-clockwise until the rocking motion is eliminated.

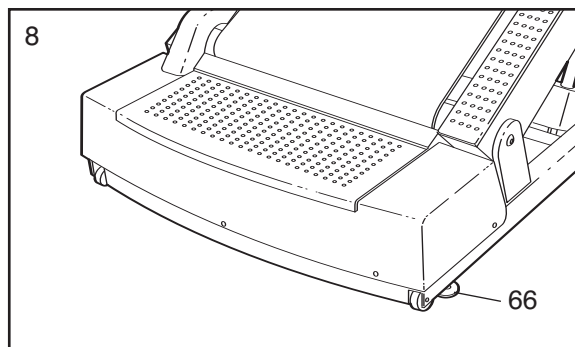

9. **Make sure that all parts are properly tightened before you use the INCLINE TRAINER.** Keep the included allen wrenches for adjustment purposes. To protect the floor or carpet from damage, place a mat under the INCLINE TRAINER.

HOW TO MOVE THE INCLINE TRAINER

Before moving the INCLINE TRAINER, adjust the incline to 30% and then unplug the power cord.

Note: It may be necessary to disconnect the CATV cable and the network wire from the INCLINE TRAINER, depending on how far the INCLINE TRAINER will be moved.

Due to the size and weight of the INCLINE TRAINER, moving it requires two persons. Whilst one person lifts the indicated end of the INCLINE TRAINER, firmly hold the handrails and tip the INCLINE TRAINER forward until it rolls on the front wheels. Carefully move the INCLINE TRAINER to the desired location and then lower it back to the level position. Note: Another way to move the INCLINE TRAINER is to have one person stand on each side of it, lift the frame, and move it on the rear wheels.

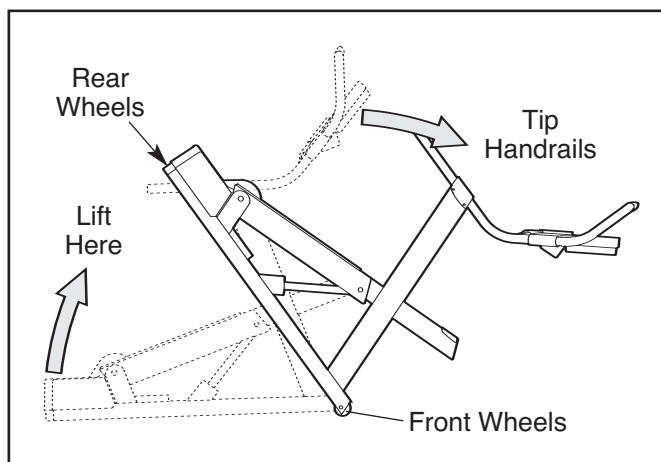

CAUTION: To reduce the risk of injury, use extreme caution whilst moving the INCLINE TRAINER. Do not attempt to move the INCLINE TRAINER over uneven surfaces.

HOW TO CONNECT THE INCLINE TRAINER

HOW TO CONNECT THE POWER CORD

This product must be grounded. If it should malfunction or break down, grounding provides a path of least resistance for electric current to reduce the risk of electric shock. **Note: These instructions describe how the power cord should be connected in the UK, Germany, Italy, Spain, or France. To connect the power cord in other countries, see the instruction sheet accompanying this manual.**

⚠ DANGER: Improper connection of the equipment-grounding conductor can result in an increased risk of electric shock. Check with a qualified electrician or serviceman if you are in doubt as to whether the product is properly grounded. Do not modify the plug provided with the product—if it will not fit the outlet, have a proper outlet installed by a qualified electrician. Do not use an adapter to connect the plug to an improper receptacle.

This product is for use on a dedicated circuit. **In the UK, Germany, Italy, Spain, or France, use a dedicated 10-amp, 240-volt circuit.** No other appliance should be on the same circuit. The product is equipped with a cord having an equipment-grounding conductor and a grounding plug. Plug one end of the cord into the INCLINE TRAINER as shown in drawing 1. Attach the cord bracket over the cord with the included hex key and the two bracket screws.

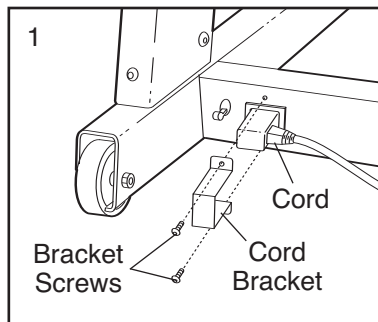

Next, plug the grounding plug into a receptacle as shown in drawing 2 at the right. Do not modify the plug or the receptacle. Do not use an adapter or an extension cord.

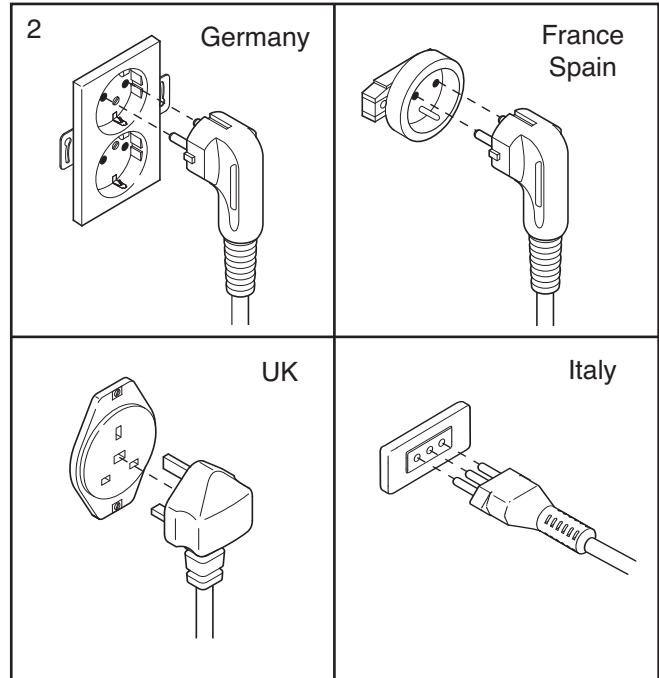

HOW TO CONNECT A CATV CABLE

If your **INCLINE TRAINER** has the **Workout TV console**, a CATV cable must be connected to the **INCLINE TRAINER** for cable TV stations to be viewed.

Locate the cable jack on the front of the **INCLINE TRAINER**. Connect the CATV cable to the cable jack using the PAL adapter. Route the cable so that it will not be pinched or crushed by the wheels when the incline is changed.

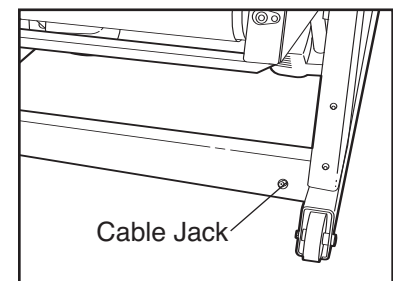

A satellite receiver, VCR, or DVD player can also be connected to the **INCLINE TRAINER**. Connect a CATV cable from the coaxial output on your equipment (usually labeled TV OUT or RF OUT) to the cable jack on the front of the **INCLINE TRAINER**.

Note: Audio/video equipment without coaxial outputs (some satellite receivers and DVD players) requires a RF modulator to work correctly with the **INCLINE TRAINER**. RF modulators are not available from FreeMotion Fitness, but are available at electronics stores. See the owner's manual for the equipment you wish to connect to determine if an RF modulator is needed, or contact your local audio/visual service provider.

HOW TO UPGRADE YOUR CONSOLE

Your INCLINE TRAINER has been pre-configured to operate with the Basic console and the Workout TV console (see the drawings below).

For information about the features of the Basic console, see page 13. To learn about the state-of-the-art Workout TV console, see page 25.

To upgrade your console whenever you choose, simply contact your local FreeMotion Fitness Sales Representative.

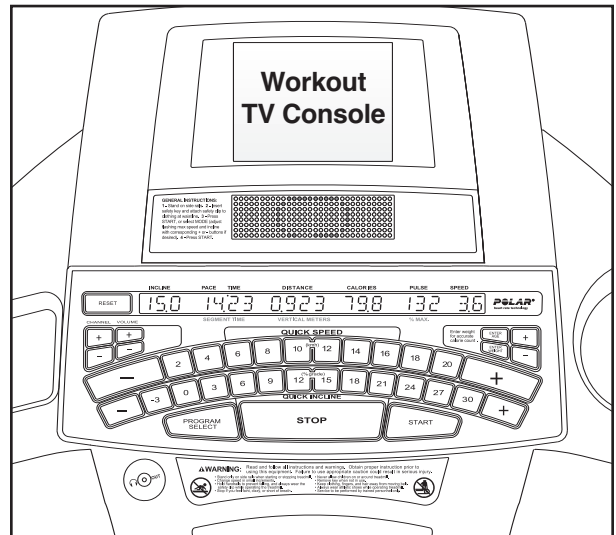
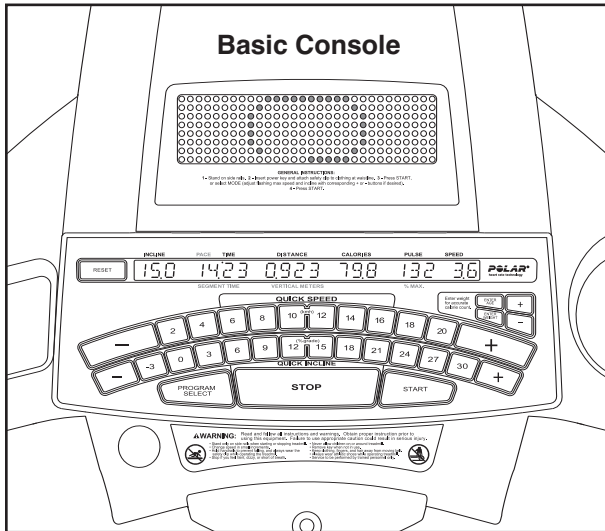

HOW TO USE THE BASIC CONSOLE

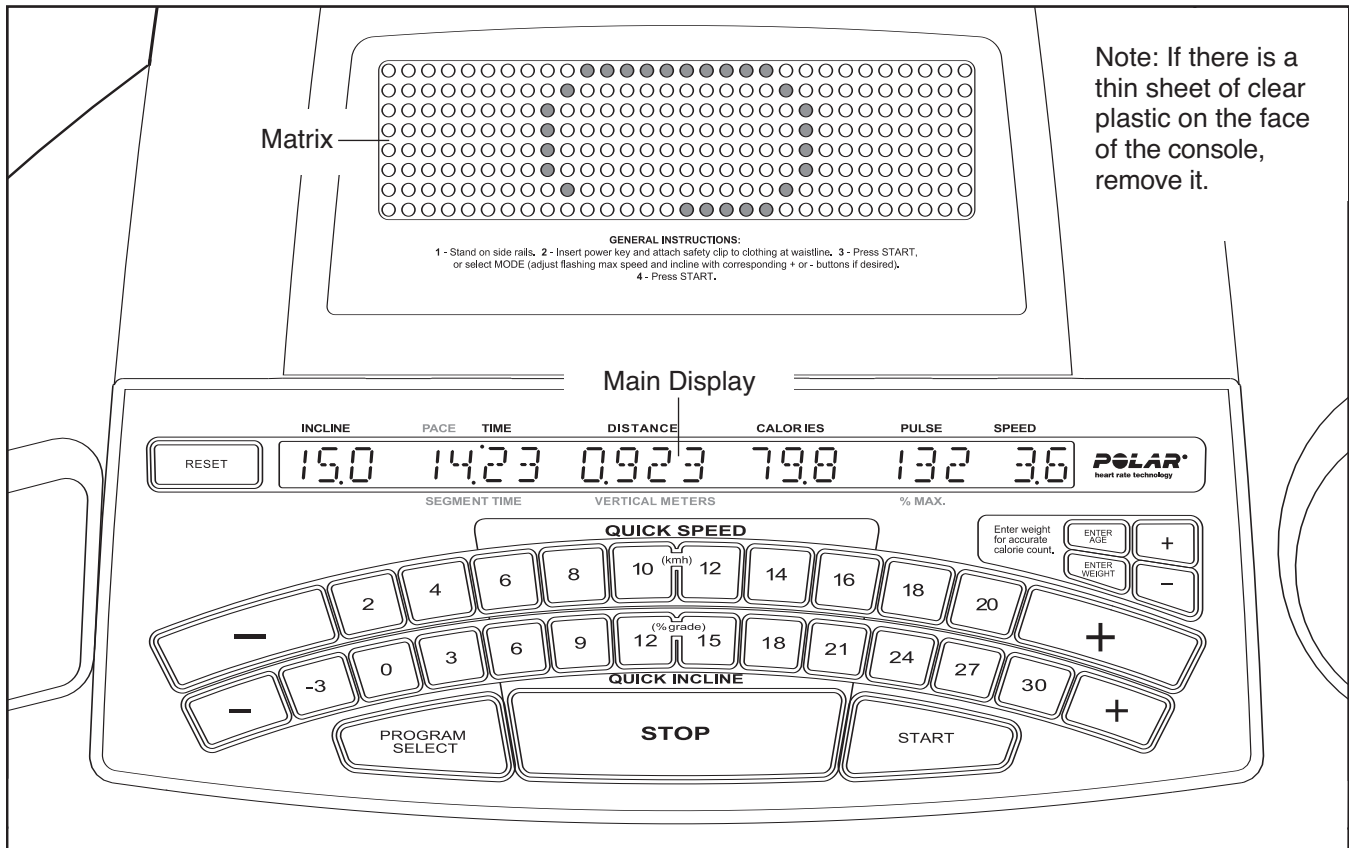

FEATURES OF THE CONSOLE

The Basic console offers an impressive array of features to help you get the most from your exercise.

When the manual mode of the console is selected, the speed and incline of the INCLINE TRAINER can be changed with a touch of a button. As you exercise, the console will provide continuous exercise feedback. You can even measure your heart rate using the built-in pulse sensor.

Six preset workout programs are also offered. Each program automatically controls the speed and incline of the INCLINE TRAINER to give you an effective workout.

In addition, the console offers three pulse-driven programs that adjust the speed and incline of the INCLINE TRAINER to keep your heart rate near target levels during your workouts, and a unique fitness test program that measures your relative fitness level. Note: The pulse-driven programs and the fitness test program require the use of a Polar®-compatible chest pulse sensor (not included).

CAUTION: Before operating the console, read the following precautions.

- Do not stand on the walking belt when turning on the power.
- Always wear the clip (see the drawing at the right) whilst operating the INCLINE TRAINER.
- Adjust the speed in small increments to avoid sudden jumps in speed.
- The pulse sensor is not a medical device. Various factors may affect the accuracy of heart rate readings. The pulse sensor is intended only as an exercise aid in determining heart rate trends in general.
- If you have heart problems, or if you are over 60 years of age and have been inactive, do not use the pulse-driven programs. If you are taking medication regularly, consult your physician to find whether the medication will affect your exercise heart rate.
- To reduce the possibility of electric shock, keep the console dry. Avoid spilling liquids on the console and place only a sealed water bottle in the water bottle holder.

GETTING STARTED

1 Plug in the power cord.

See HOW TO CONNECT THE POWER CORD on page 10.

2 Move the on/off circuit breaker to the on position.

Locate the on/off circuit breaker on the INCLINE TRAINER near the power cord. Switch the on/off circuit breaker to the on position.

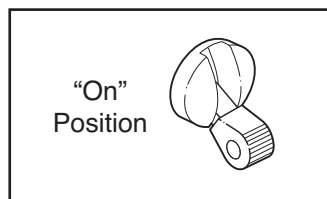

3 Insert the key into the console.

Note: The console can be set to be used without the key. See step 11 on page 23 for instructions. **If the console is set to be used without the key, go to step 4.**

Find the key and the clip on the console and attach the clip to the waistband of your clothes.

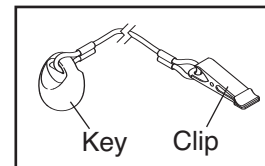

Next, insert the key into the console.

Test the clip by carefully taking a few steps backward until the key is pulled from the console. If the key is not pulled from the console, adjust the position of the clip as needed.

Insert the key into the console again. After a moment, various displays and indicators on the console will light.

4 Enter your weight.

Although you can use the console without entering your weight, the console will count the Calories that you burn more accurately if you enter your weight. To enter your weight, first press the ENTER WEIGHT button. The words ENTER WEIGHT and the current weight setting will appear in the main display.

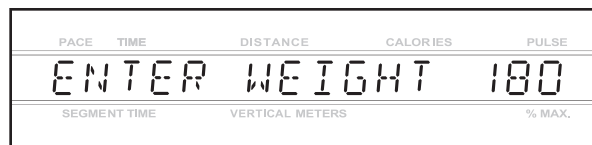

Press the + and – buttons beside the ENTER WEIGHT button to enter your weight. The buttons can be held down to enter your weight quickly.

To use the manual mode of the console, follow the steps beginning on page 15. **To use a preset program,** see page 17. **To use a pulse-driven program,** see page 19. **To use the fitness test program,** see page 20. **To use the maintenance mode,** see page 22.

HOW TO USE THE MANUAL MODE

1 Insert the key into the console.

See GETTING STARTED on page 14.

2 Select the manual mode.

When the key is inserted, the manual mode will automatically be selected. If a program has been selected, press the PROGRAM SELECT button repeatedly until the main display appears as shown below.

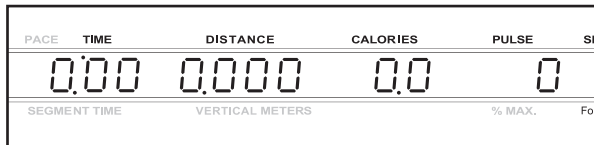

3 Press the START button or the SPEED + button to start the walking belt.

A moment after the button is pressed, the walking belt will begin to move at 3 kph. Hold the handrails and begin walking.

As you exercise, change the speed of the walking belt as desired by pressing the SPEED + and - buttons. Each time a button is pressed, the speed setting will change by 0.1 kph; if a button is held down, the speed setting will change in increments of 0.5 kph. To change the speed quickly, press the QUICK SPEED buttons. The speed range is 0.8 kph to 20 kph. Note: After the buttons are pressed, it may take a moment for the INCLINE TRAINER to reach the selected speed setting.

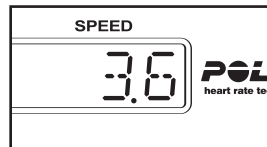

To stop the walking belt, press the STOP button. The time will begin to flash in the main display. To restart the walking belt, press the START button or the SPEED + button and then adjust the speed as desired.

4 Change the incline of the INCLINE TRAINER as desired.

To change the incline of the INCLINE TRAINER, press the INCLINE + and - buttons. Each time a button is

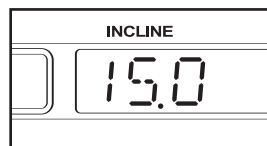

pressed, the incline will change by 0.5%. To change the incline quickly, press the QUICK INCLINE buttons. The incline range is -3% to 30%. Note: After the buttons are pressed, it may take a moment for the INCLINE TRAINER to reach the selected incline setting.

5 Follow your progress with the matrix and the main display.

The matrix—When the manual mode is selected, the matrix will display a 400-metre track. As you exercise, the indicators around the track will light in sequence to show your position on the track. Each time you complete a 400-metre lap, a new lap will begin.

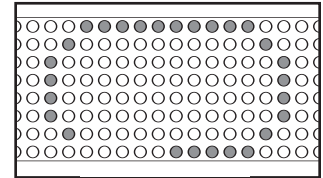

The main display—The main display will show the following information:

Incline—The left end of the main display will show the incline level of the INCLINE TRAINER.

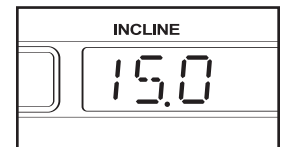

Pace/Time—When the manual mode is selected, this section of the main display will show the elapsed time. When a preset program or a pulse-driven program is selected, the display will show the time remaining in the program and the time remaining in the current segment of the program. The display will change from one number to the other every seven seconds. During the fitness test program, the display will show the elapsed time and the time remaining in the current segment of the program. Note: Any time that the speed setting changes, the display will show your current pace (in *minutes per kilometre*) for seven seconds.

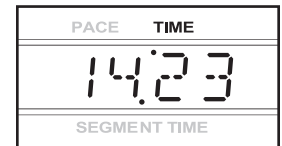

Distance/Vertical

Meters—The centre of the main display will show the distance that you have walked and the number of vertical meters you have climbed. The display will change from one number to the other every seven seconds.

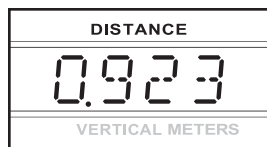

Calories—This section of the main display will show the approximate number of Calories you have burned.

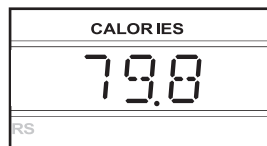

Pulse/% Max—When you are using the handgrip pulse sensor or a Polar®-compatible chest pulse sensor (not included), this section of the main display will show your heart rate (see step 6). When a pulse-driven program is selected, the display will show your heart rate and the corresponding *percentage* of your *estimated maximum heart rate*. (See step 5 on page 19 for an explanation of your estimated maximum heart rate.) The display will change from one number to the other every seven seconds.

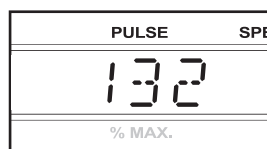

Speed—The right end of the main display will show the speed of the walking belt.

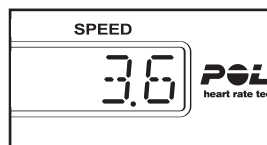

To reset the displayed time, distance, vertical meters, and Calories at any time, press the RESET button.

6 Measure your heart rate if desired.

To measure your heart rate, **stand on the foot rails** and hold the handgrip pulse sensor with both hands. Your palms must be resting on the upper contacts and your fingers must be touching the lower contacts—**avoid moving your hands**.

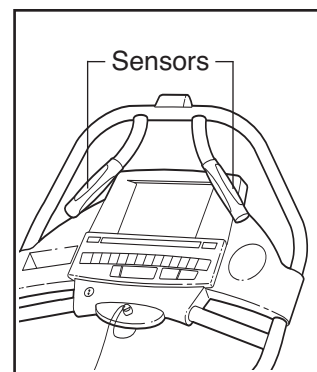

When your pulse is detected, the words ACQUIRING PULSE will appear in the main display and then your heart rate will be shown. **For the most accurate heart rate reading, continue to hold the contacts for at least 15 seconds.** Note: Using a cell phone near the pulse sensors may cause a false heart rate reading.

7 When you are finished exercising, stop the walking belt and remove the key.

Step onto the foot rails and press the STOP button. Next, remove the key from the console and put the key in a secure place.

When the INCLINE TRAINER is not in use, switch the on/off circuit breaker near the power cord to the off position and unplug the power cord.

HOW TO USE PRESET PROGRAMS

1 Insert the key into the console.

See GETTING STARTED on page 14.

2 Select one of the six preset programs.

When the key is inserted, the manual mode will be selected. To select one of the six preset programs, press the PROGRAM SELECT button repeatedly until the words **CARDIO WALK 1**, **CARDIO WALK 2**, **ENDURANCE 1**, **ENDURANCE 2**, **FINISH LINE 1**, or **FINISH LINE 2** appear in the main display. Note: **CARDIO WALK 1** is a level one (low-intensity) walking program; **CARDIO WALK 2** is a level one walking program; **ENDURANCE 1** is a level two (medium-intensity) walking program; **ENDURANCE 2** is a level two running program; **FINISH LINE 1** is a level three (high-intensity) walking program; and **FINISH LINE 2** is a level three running program.

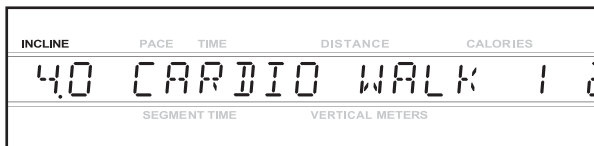

When a preset program is selected, the maximum incline setting for the program will flash at the left end of the main display and the maximum speed setting will flash at the right end. After three seconds, the name of the selected program, the level of the program, and the total program time will begin to scroll across the main display. If desired, you can change the maximum incline setting or the maximum speed setting by pressing the **INCLINE** or **SPEED** buttons. If you increase either setting, the difficulty level of the entire program will increase; if you decrease either setting, the difficulty level of the entire program will decrease.

When a preset program is selected, the matrix will show a graph representing the speed settings for the program.

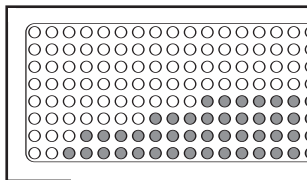

3 Press the **START** button or the **SPEED +** button to start the program.

A moment after the button is pressed, the **INCLINE TRAINER** will automatically adjust to the first speed and incline settings for the program. Hold the handrails and begin walking.

Each program is divided into several time segments of different lengths. The main display will show both the time remaining in the program and the time remaining in the current segment of the program. One speed setting and one incline setting are programmed for each segment. The speed setting for the first segment is shown in the flashing **CURRENT SEGMENT** column of the matrix. (The incline settings are not shown in the matrix.) The speed settings for upcoming segments are shown in the columns to the right.

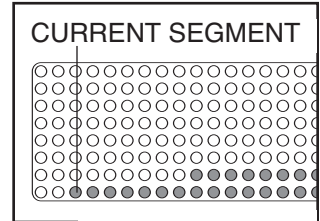

When only three seconds remain in the first segment of the program, both the **CURRENT SEGMENT** column and the column to the right will flash and a series of tones will sound. In addition, if the speed and/or incline of the **INCLINE TRAINER** is about to change, the speed setting and/or the incline setting will flash in the main display to alert you. When the first segment is completed, *all speed settings will move one column to the left*. The speed setting for the second segment will then be shown in the flashing **CURRENT SEGMENT** column and the **INCLINE TRAINER** will automatically adjust to the speed and incline settings for the second segment. Note: If all of the indicators in the **CURRENT SEGMENT** column are lit after the speed settings have moved to the left, *the speed settings will move downward* so that only the highest indicators appear in the matrix. If some of the indicators in the **CURRENT SEGMENT** column are not lit when the speed settings move to the left again, the speed settings will move back up.

The program will continue in this way until the speed setting for the last segment is shown in the **CURRENT SEGMENT** column and no time remains in the program. The walking belt will then slow to a stop.

Note: You can manually override the speed or incline setting for the current segment by pressing the **SPEED** or **INCLINE** buttons. Every few times a **SPEED** button is pressed, an additional indicator will light or darken in the **CURRENT SEGMENT** column. (If any of the columns to the right of the **CURRENT SEGMENT** column have the same number of lit indicators as the **CURRENT SEGMENT** column, an additional indicator may light or darken in those columns as well.) If you manually adjust the speed setting so that all of the

indicators in the CURRENT SEGMENT column are lit, the speed settings in the matrix will *not* move downward as described above. **Important:** **When the next segment of the program begins, the INCLINE TRAINER will automatically adjust to the speed and incline settings for the next segment.**

To stop the program, press the STOP button. The time will begin to flash in the main display. To restart the program, press the START button or the SPEED + button. The walking belt will begin to move at 3 kph. When the next segment of the program begins, the INCLINE TRAINER will automatically adjust to the speed and incline settings for the next segment.

4 Follow your progress with the main display.

See step 5 on page 15.

5 Measure your heart rate if desired.

See step 6 on page 16.

6 When the program is completed, remove the key.

Step onto the foot rails. Remove the key from the console and put the key in a secure place.

When the INCLINE TRAINER is not in use, switch the on/off circuit breaker near the power cord to the off position and unplug the power cord.

HOW TO USE PULSE-DRIVEN PROGRAMS

Pulse-driven programs automatically control the incline and speed of the INCLINE TRAINER to keep your heart rate near a target level whilst you exercise. Follow the steps below to use a pulse-driven program.

- 1 Put on a Polar®-compatible chest pulse sensor (not included).** Note: Using a cell phone near the chest pulse sensor may cause a false heart rate reading.

You must wear a chest pulse sensor to use a pulse-driven program. See the instructions included with your chest pulse sensor.

- 2 Insert the key into the console.**

See GETTING STARTED on page 14.

- 3 Select one of the three pulse-driven programs.**

When the key is inserted, the manual mode will be selected. To select one of the three pulse-driven programs, press the PROGRAM SELECT button repeatedly until the words **CARDIO WALK PULSE**, **ENDURANCE PULSE**, or **MANUAL PULSE** appear in the main display. Note: The **CARDIO WALK PULSE** program will keep your heart rate near 65% of your *estimated maximum heart rate* (see step 5 at the right for an explanation of your estimated maximum heart rate). The **ENDURANCE PULSE** program will keep your heart rate near 80% of your estimated maximum heart rate. The **MANUAL PULSE** program will keep your heart rate near a percentage that you select.

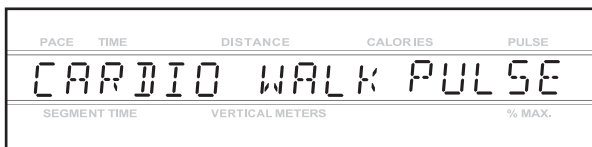

When a pulse-driven program is selected, the name of the selected program and the total program time will scroll across the main display. The words **ENTER AGE** and the current age setting will then be shown.

During pulse-driven programs, the matrix will show a moving graphic that represents your heart rate. Each time a heart-beat is detected, an additional peak will appear in the graphic.

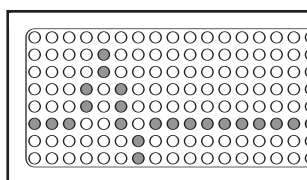

- 4 Enter your age.**

You must enter your age to use a pulse-driven program. To enter your age, press the + and – buttons beside the **ENTER AGE** button. The buttons can be held down to enter your age quickly. The age range is 20 to 80 years. When your age is shown, press the **ENTER AGE** button.

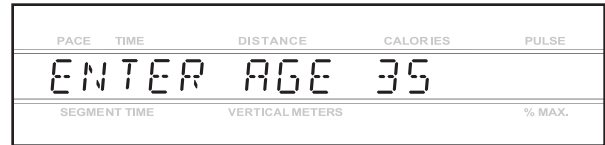

If you have selected the **CARDIO WALK PULSE or **ENDURANCE PULSE** program, go to step 6. If you have selected the **MANUAL PULSE** program, go to step 5.**

- 5 Enter a target heart rate setting.**

After you have entered your age, the words **ENTER PERCENT** and the target heart rate setting for the program will be shown in the main display. The target heart rate setting represents a *percentage* of your *estimated maximum heart rate*. Your estimated maximum heart rate is 220 minus your age. For example, if you are 30 years old, your estimated maximum heart rate is 190 beats per minute ($220 - 30 = 190$). If you are 30 years old, a target heart rate setting of 50 is equal to 95 beats per minute (50% of 190 is 95).

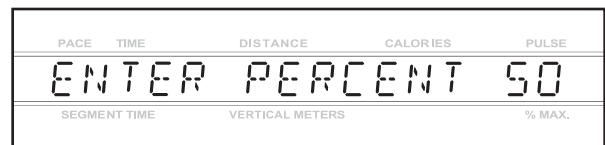

If desired, you can change the target heart rate setting by pressing the + and – buttons beside the **ENTER AGE** button. The buttons can be held down to change the target heart rate setting quickly. The target heart rate setting can be from 50% to 85% of your estimated maximum heart rate.

- 6 Press the **START** button or the **SPEED +** button to start the program.**

A moment after the button is pressed, the INCLINE TRAINER will automatically adjust to the first speed and incline settings for the program. Hold the handrails and begin walking.

Each pulse-driven program is divided into one-minute segments. (The main display will show both the time remaining in the program and the time remaining in the current segment of the program.) One target heart rate setting is programmed for each segment. (During the MANUAL PULSE program, the same target heart rate setting will be programmed for all segments.)

When only three seconds remain in the first segment of the program, a series of tones will sound and the speed and/or incline of the INCLINE TRAINER will change, if needed, to bring your heart rate closer to the target heart rate setting for the next segment. The speed and/or incline setting will flash in the main display to alert you before the speed and/or incline changes. The program will continue until no time remains in the program. The walking belt will then slow to a stop.

If the speed or incline setting for the current segment is too high or too low, you can adjust the setting with the SPEED or INCLINE buttons. However, if you *decrease* the speed, the incline will automatically *increase*; if you *increase* the speed, the incline will *decrease*. If you *increase* the incline, the speed will *decrease*; if you *decrease* the incline, the speed will *increase*. The INCLINE TRAINER will always attempt to keep your heart rate near the target heart rate setting for the current segment. Note: When the incline reaches the lowest setting, the speed cannot be increased any further. When the incline reaches the highest setting, the speed cannot be decreased any further.

If your pulse is not detected during the program, the letters PLS will flash in the main display and the incline and speed of the INCLINE TRAINER may automatically decrease until your pulse is detected. If this occurs, see the instructions included with your chest pulse sensor.

To stop the program at any time, press the STOP button. Pulse-driven programs should not be stopped temporarily and then restarted. To use a pulse-driven program again, reselect the program and start it at the beginning.

7 Follow your progress with the main display.

See step 5 on page 15.

8 When the program is completed, remove the key.

See step 6 on page 18.

HOW TO USE THE FITNESS TEST PROGRAM

The fitness test program measures your relative fitness level. For the best results, the program should be used at a time when your energy level is high; the program should not be used if you have already exercised during the day. Follow the steps below to use the program.

1 Put on a Polar®-compatible chest pulse sensor (not included).

You must wear a chest pulse sensor to use the fitness test program. See the instructions included with your chest pulse sensor.

2 Insert the key into the console.

See GETTING STARTED on page 14.

3 Select the fitness test program.

When the key is inserted, the manual mode will be selected. To select the fitness test program, press the PROGRAM SELECT button repeatedly until the words FITNESS TEST appear in the main display.

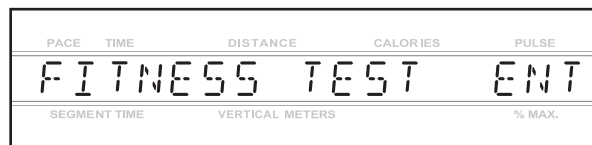

When the fitness test program is selected, the words FITNESS TEST will scroll across the main display. The words ENTER AGE and the current age setting will then be shown.

During fitness test program, the matrix will show a moving graphic that represents your heart rate. Each time a heart-beat is detected, an additional peak will appear in the graphic.

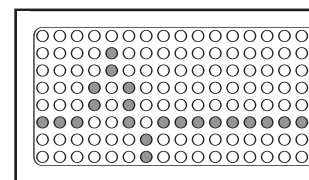

4 Enter your age.

You must enter your age to use the fitness test program. To enter your age, see step 4 on page 19.

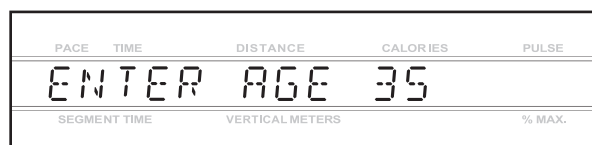

5 Press the START button to start the program.

When the button is pressed, the walking belt will begin to move at 2.4 kph and the incline of the INCLINE TRAINER will automatically adjust to 3%. Hold the handrails and begin walking.

The fitness test program is divided into seven, four-minute levels. One speed setting and one incline setting are programmed for each level. At the end of each minute of the program, the words LEVEL 1 will appear in the main display and then a tone will sound.

PACE	TIME	DISTANCE	CALORIES	PULSE	SP
0:35	LEVEL	1		118	
SEGMENT TIME	VERTICAL METERS	% MAX.	For		

When the first four-minute level of the program is completed, the second four-minute level will begin. The speed of the walking belt will then increase to 4 kph and the incline will change to 4%.

At the beginning of each four-minute level, the speed and/or incline of the INCLINE TRAINER will automatically increase. The fitness test program will continue in this way until your heart rate reaches 70% of your estimated maximum heart rate and the current four-minute level is completed. *The fitness test program will then end, regardless of how many levels remain.*

When the fitness test program is completed, the word COOL-DOWN will be shown in the main display and a two-minute cool-down period will begin. The incline and speed will then decrease.

PACE	TIME	DISTANCE	CALORIES	PULSE	SP
1:49	COOL	DOWN		118	
SEGMENT TIME	VERTICAL METERS	% MAX.	For		

When the cool-down period is completed, the walking belt will slow to a stop and your fitness level will be shown in the main display. There are ten fitness levels; fitness level 10 is the highest.

PACE	TIME	DISTANCE	CALORIES	PULSE
FIT LEVEL 06				
SEGMENT TIME	VERTICAL METERS	% MAX.		

Note: The SPEED and INCLINE buttons will not function whilst the fitness test program is selected. If your pulse is not detected during the program, the letters PLS will flash in the main display. If your pulse is not detected at the end of any four-minute level, the fitness test program will end and the main display will show a fitness level of 0.

The fitness test program cannot be stopped temporarily and then restarted. However, the program can be stopped at any time with the STOP button. The main display will then show an estimated fitness level.

6 When the program is completed, remove the key.

See step 6 on page 18.

HOW TO USE THE MAINTENANCE MODE

The console features a maintenance mode that allows you to access information and to view and change various default settings. Follow the steps below to use the maintenance mode.

1 Insert the key into the console.

See GETTING STARTED on page 14.

2 Hold down the ENTER AGE button and the RESET button simultaneously for two seconds to select the maintenance mode.

When the maintenance mode is selected, the words MAINTENANCE MODE will appear in the main display.

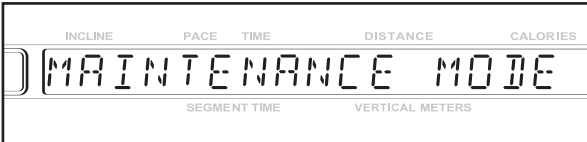

3 Press the ENTER AGE button to view the total number of hours that the INCLINE TRAINER has been used.



4 Press the ENTER AGE button again to view the total distance that the walking belt has moved.

Note: Disregard the word MILES in the main display; the number in the main display is the total number of kilometres.



5 Press the ENTER AGE button again and set the delay time for the timeout mode.

Any time that the INCLINE TRAINER is not used for several minutes, the console will enter a timeout mode and the words PUSH ANY BUTTON TO START A NEW PROGRAM will begin to scroll across the main display. To set the number of min-

utes before the console will enter the timeout mode, press the + and – buttons beside the ENTER AGE button. The delay time can be from 1 to 15 minutes.



6 Press the ENTER AGE button again and set the program time for the CARDIO WALK 1, ENDURANCE 1, and FINISH LINE 1 programs.

The CARDIO WALK 1, ENDURANCE 1, and FINISH LINE 1 programs can be set to last for 20, 30, or 40 minutes. To change the setting, press the + and – buttons beside the ENTER AGE button.



7 Press the ENTER AGE button again and set the program time for the CARDIO WALK 2, ENDURANCE 2, and FINISH LINE 2 programs.

The CARDIO WALK 2, ENDURANCE 2, and FINISH LINE 2 programs can be set to last for 20, 30, or 40 minutes. To change the setting, press the + and – buttons beside the ENTER AGE button.



8 Press the ENTER AGE button again to check for controller errors.

If there are no controller errors, the words NO CONTROLLER ERRORS will appear in the main display. If there is a controller error, the name of the error will appear in the main display. If this occurs, press the RESET button. If the same controller error appears repeatedly, please contact your distributor.



9 Press the ENTER AGE button again to check for system errors.

If there are no system errors, the words NO SYSTEM ERRORS will appear in the main display. If the words LUBRICATE DECK appear in the main display, the walking platform should be checked for adequate lubricant. Follow the instructions in step 4 on page 27 to lubricate the walking platform if necessary. Then, see HOW TO RESET THE LUBE REMINDER on page 24. If the words INCLINE OVERHEAT ERROR appear in the main display, press the RESET button. If the same system error appears repeatedly, please contact your distributor.

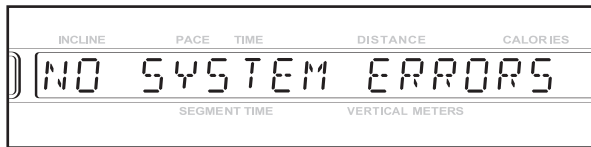

10 Press the ENTER AGE button again and enable or disable the lubrication reminder.

The console can be set to display the words LUBRICATE DECK every five minutes when the walking platform needs to be lubricated. Press the + or – button beside the ENTER AGE button until the words LUBE REMINDER ENABLED appear in the main display. To turn off the lubrication reminder, press the + or – button until the words LUBE REMINDER DISABLED appear.



11 Press the ENTER AGE button again and enable or disable the safety key.

To require the use of the safety key with the console, press the + or – button beside the ENTER AGE button until the words SAFETY KEY ENABLED appear in the main display. To allow the INCLINE TRAINER to be used without the key, press the + or – button until the words SAFETY KEY DISABLED appear. **CAUTION: If the safety key is missing or damaged, please contact your distributor.**



If you have the Basic console, go to step 16. If you have the Workout TV console, go to step 12.

12 Press the ENTER AGE button again and enable or disable the TV.

To make the TV available for use, press the + or – button beside the ENTER AGE button until the words TV POWER ON appear in the main display. To prevent the TV from being used, press the + or – button until the words TV POWER OFF appear.



If you have disabled the TV, go to step 16. If you have enabled the TV, go to step 13.

13 Press the ENTER AGE button again and select a cable TV connection or an antenna connection.

If you are using a cable TV connection, press the + or – button beside the ENTER AGE button until the words TV MODE CABLE STATIONS appear in the main display. If you are using an antenna connection, press the + or – button until the words TV MODE AIR STATIONS appear.



14 Press the ENTER AGE button again and program TV channels.

The console has the capability to find and store in memory all of the valid TV channels in your area. Whilst the words PRESS CHANNEL UP TO SCAN TV CHANNELS are scrolling across the main display, press the CHANNEL + button to start the channel scanning process.



The console will begin scanning all TV channels. If no broadcast signal is detected on a channel, the channel will be skipped; if a signal is detected, a tone will sound and the channel will be stored in memory. This process will continue until the highest channel is reached. The lowest channel stored in memory will then appear in the main display.

15 Press the **ENTER AGE** button again and delete or add TV channels.

After all valid TV channels have been stored in the console's memory, you can delete unwanted channels or add other channels. To delete or add a channel, first press the **CHANNEL +** and **-** buttons until the channel appears in the main display.



If the word **DELETE** appears beside the channel, press the **+** or **-** button beside the **ENTER AGE** button to delete the channel. If the word **ADD** appears beside the channel, press the **+** or **-** button beside the **ENTER AGE** button to add the channel. Then, select the next channel that you want to delete or add. Repeat this process until you have finished deleting or adding channels.

16 Hold down the **ENTER AGE** button and the **RESET** button simultaneously for two seconds to exit the maintenance mode.

To exit the maintenance mode at any time, hold down the **ENTER AGE** button and the **RESET** button simultaneously for two seconds.

HOW TO RESET THE LUBE REMINDER

If the words **LUBRICATE DECK** appear in the main display when the maintenance mode is selected (see step 9 on page 23), follow the steps below to reset the lube reminder.

1 Insert the key into the console.

See **GETTING STARTED** on page 14.

2 Hold down the **STOP** button and the **RESET** button simultaneously for three seconds.

HOW TO USE THE WORKOUT TV CONSOLE

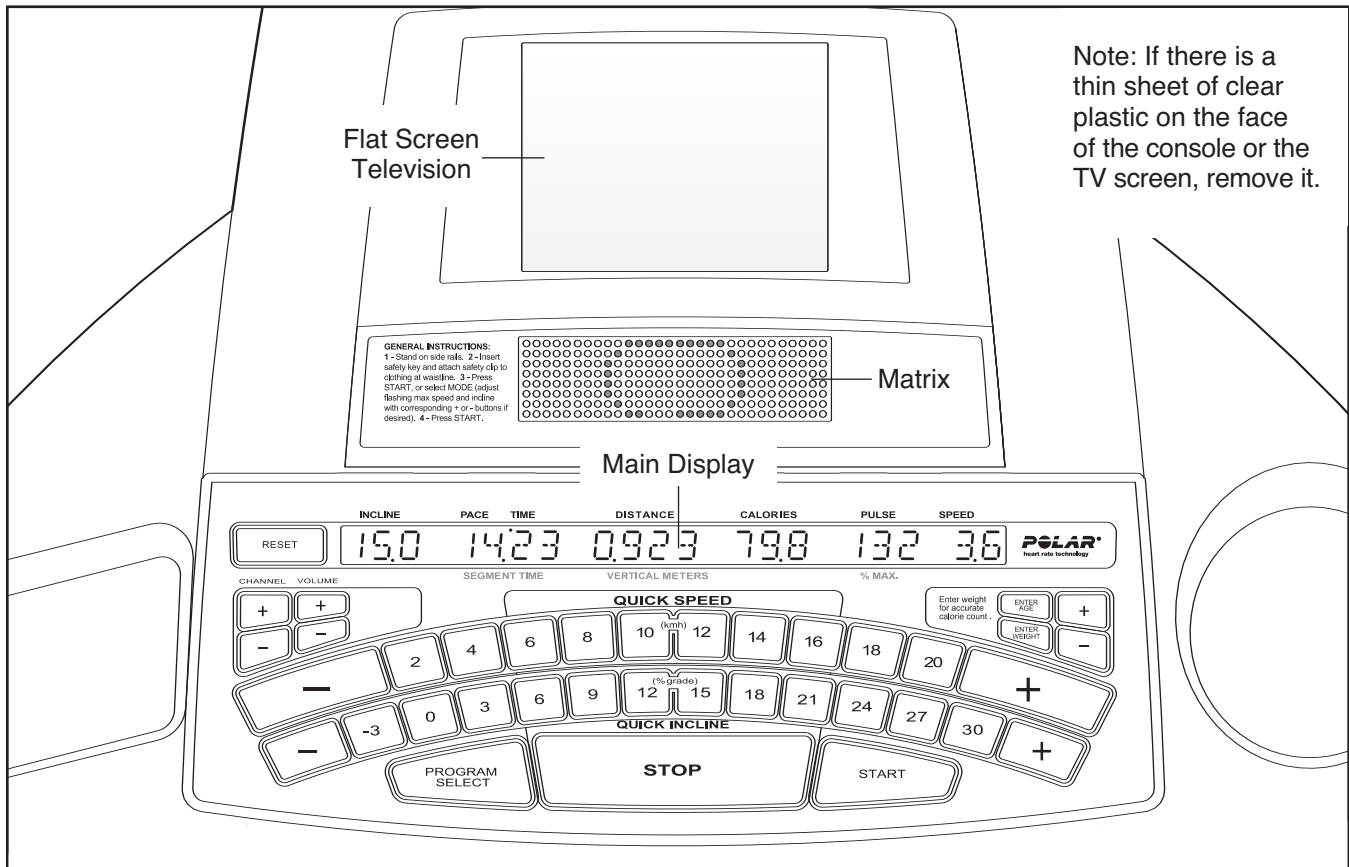

FEATURES OF THE CONSOLE

The state-of-the-art Workout TV console offers an impressive array of features to make your workouts more effective and enjoyable.

When the manual mode of the console is selected, the speed and incline of the INCLINE TRAINER can be changed with a touch of a button. As you exercise, the console will provide instant exercise feedback. You can even measure your heart rate using the built-in pulse sensor.

Six preset workout programs are also offered. Each program automatically controls the speed and incline of the INCLINE TRAINER to give you an effective workout.

In addition, the console offers three pulse-driven programs that adjust the speed and incline of the INCLINE TRAINER to keep your heart rate near target levels during your workouts, and a unique fitness test program that measures your relative fitness level. Note: The pulse-driven programs and the fitness test program require the use of a Polar®-compatible chest pulse sensor (not included).

As you exercise, the personal TV will allow you to enjoy the programs of your choice.

To upgrade your INCLINE TRAINER with the Workout TV console, contact your distributor.

HOW TO USE THE WORKOUT TV CONSOLE

The Workout TV console offers exactly the same features as the Basic console, but incorporates a built-in personal TV in addition. Note: The console has the capability to find and store in memory all of the valid TV channels in your area. You can even screen out unwanted channels. See pages 22 to 24 for instructions.

Note: A CATV cable must be connected to the INCLINE TRAINER in order for cable TV stations to be viewed. See HOW TO CONNECT A CATV CABLE on page 10 for instructions.

To use the Workout TV console, follow the instructions on pages 14 to 24 of this manual. To use the personal TV, follow the instructions below.

1 Select the desired channel.

Press the CHANNEL + and – buttons to select a channel. The selected channel will appear in the main display.



Note: If a satellite receiver, VCR, or DVD player is connected, the channel must be changed at the satellite receiver, VCR, or DVD player.

2 Put on headphones (not included) if desired.

To listen to television programs using headphones, plug your headphones into the jack on the left side of the console. Note:

Use only headphones with padded earcups.

Do not use ear buds that fit inside the ear.

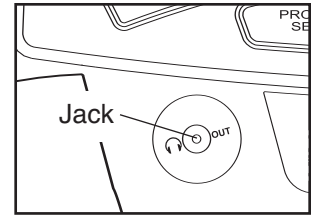

3 Adjust the volume.

Press the VOLUME + and – buttons to select the desired volume. The selected volume setting will appear in the main display.



PREVENTIVE MAINTENANCE

Regular maintenance is necessary for the optimal performance and long life of the INCLINE TRAINER. Please read and follow all instructions below. If the INCLINE TRAINER is not maintained as described, components may wear excessively and the INCLINE TRAINER may be damaged. If you have questions about maintenance, please contact your distributor. **CAUTION: Make sure to remove the key and unplug the power cord before performing any maintenance procedures.**

WEEKLY MAINTENANCE

1. **Unplug the power cord.** Inspect and properly tighten all external parts of the INCLINE TRAINER.
2. Apply a mild multi-purpose cleaner to a 100% cotton cloth and remove any dust and grime from the handrails, uprights, foot rails, frame, and motor hood. In addition, wipe the walking platform along the sides of the walking belt. **Do not wipe under the walking belt.** Apply a small amount of mild multi-purpose cleaner to a 100% cotton cloth and wipe the console and the screens. **Do not spray cleaner directly onto the INCLINE TRAINER or use ammonia or acid-based cleaners.**
3. Make sure that the walking belt is centred and properly tightened. If it is centred and runs smoothly, do not make any adjustments. If the walking belt needs to be adjusted, see pages 33 and 34.

MONTHLY MAINTENANCE

1. **Unplug the power cord.** Remove the screws attaching the motor hood and lift off the motor hood. Using a hand-held vacuum, clean the area under the electronics cover. **Be careful to avoid touching any components.**
2. Plug in the power cord and insert the key into the console. Raise the INCLINE TRAINER to the highest incline level. **Remove the key and unplug the power cord.** Check the motor belt for wear and cracks. If the motor belt needs to be replaced, see page 44 to order a new motor belt.

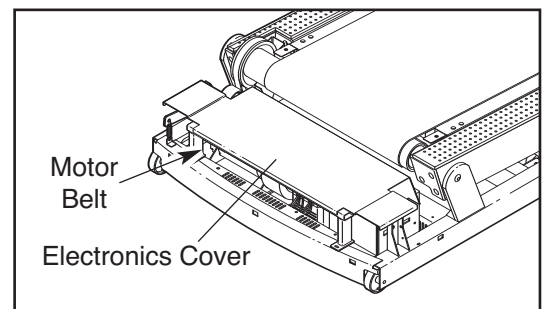

3. Plug in the power cord and insert the key into the console. Press the START button. **Be careful to avoid injury; keep your hands away from moving parts and make sure that your clothing cannot become caught in moving parts.** Whilst the walking belt is moving, check the motor for arcing. Next, check the INCLINE TRAINER for unusual noises or odors. If any of these problems exists, contact your distributor. **Remove the key and unplug the power cord.** Reattach the motor hood with the screws.

4. The walking platform should **not** be lubricated before the INCLINE TRAINER is used. However, lubricant should be applied at least once every month. To purchase a lubricant pump or lubricant packets, please contact your distributor. **Use only FreeMotion Fitness lubricant. Using other lubricants may damage the walking belt and will void the warranty. CAUTION: Before applying lubricant, remove the key and unplug the power cord.**

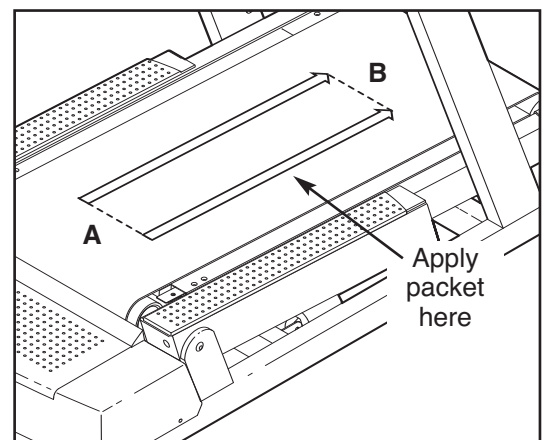

To use lubricant packets, open one packet, reach under one side of the walking belt as far as you can, and apply the entire packet between dotted line A and dotted line B. Then, apply a second packet under the opposite side of the walking belt in the same way. **After you have applied lubricant, plug in the power cord, insert the key, adjust the speed to 3 mph, and walk on the walking belt for two minutes to spread the lubricant.**

TURNING THE WALKING PLATFORM

Both sides of the walking platform are designed to be used as walking surfaces. Inspect the walking platform periodically for wear. If there is any wood showing through the phenolic coating, or if the surface is damaged, the walking platform should be turned over. The walking platform will need to be turned over after every 9,500 to 12,000 km (6,000 to 7,500 miles). Follow the instructions below to turn over the walking platform.

1. **Remove the key and unplug the power cord.** Remove the Endcap Screws (6) and the Left and Right Front Endcaps (64, 18). Remove the Roller Adjustment Bolt (16) and the Washer (17) from each side of the Front Roller (180).
2. Remove the six Front and Rear Platform Screws (8, 122). **(Note: Be very careful to avoid chipping or damaging the phenolic coating on the Walking Platform (21).** Lift the Front Roller (180) and slide it out of the Walking Belt (20). Lift the Walking Platform and the Walking Belt to the position shown by the dotted lines. Slide the Walking Platform out of the Walking Belt, turn it, and then slide it back into the Walking Belt.

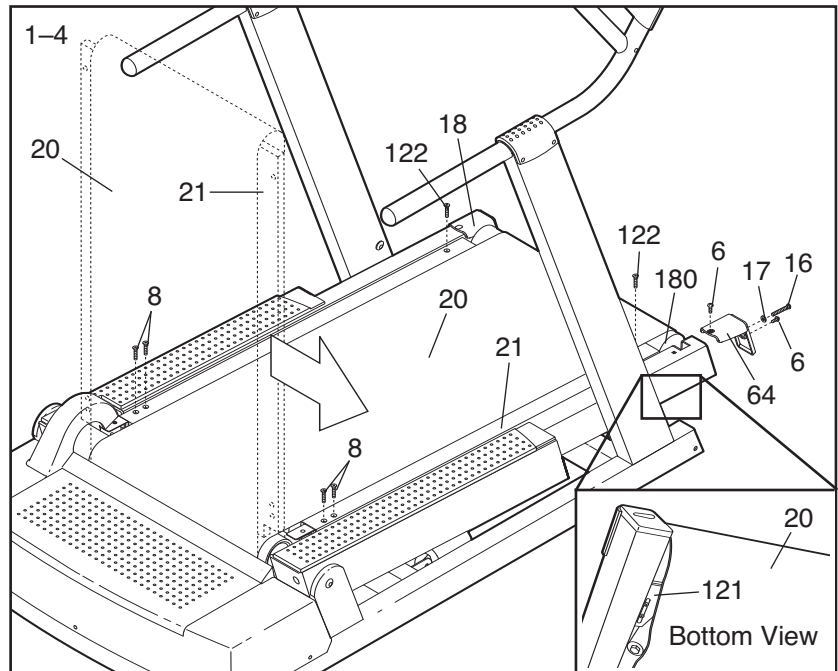

3. Lay down the Walking Platform (21) and the Walking Belt (20). Slide the Front Roller (180) back into the Walking Belt. Look under the Walking Platform and make sure that the Front Roller Guards (121) are between the Walking Belt and the Walking Platform (see the inset drawing).
4. Reattach the six Front and Rear Platform Screws (8, 122). Thread the Roller Adjustment Bolts (16) with the Washers (17) into the Roller (180). Reattach the Front Endcaps (64, 18) with the Endcap Screws (6).
5. Next, the Walking Belt (20) will need to be adjusted to the proper tension. Using chalk, make two marks on the Walking Belt exactly 1.52 m (60 in.) apart, as shown in the drawing. Tighten both Roller Adjustment Bolts (16, shown in the drawing above) until the two chalk marks move apart an additional 5 to 6 mm (3/16 to 1/4 in.). As you tighten the Roller Adjustment Bolts, the Front Roller (180) will move. **If the Front Roller stops moving, do not further tighten the Roller Adjustment Bolts—contact your distributor.** Make sure to keep the Walking Belt centred.

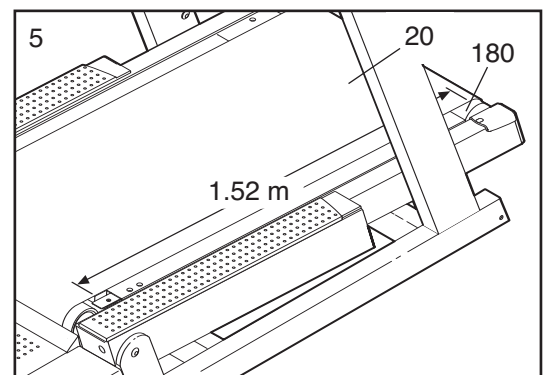

REPLACING THE WALKING PLATFORM

When both sides of the walking platform become worn, the walking platform should be replaced. The walking platform will need to be replaced after every 19,000 to 24,000 km (12,000 to 15,000 miles). See page 44 to order a new walking platform. Follow the instructions above to replace the walking platform.

REPLACING THE WALKING BELT

When the walking belt becomes worn, it should be replaced. The walking belt will need to be replaced after every 19,000 to 24,000 km (12,000 to 15,000 miles). See page 42 to order a new walking belt.

SIX-MONTH PREVENTIVE MAINTENANCE RECORD

Photocopy this form and use it to record the preventive maintenance performed on the INCLINE TRAINER. Each copy of the form can be used for six months (26 weeks). When maintenance is performed, write the date in the appropriate spaces. **Make sure to perform each maintenance procedure as described on pages 27 and 28. If the procedures are not performed as described, components may wear excessively, and the INCLINE TRAINER may be damaged.** Note: An additional copy of this form is found on page 30.

	Weekly Maintenance			Monthly Maintenance		
	Inspect and tighten all external parts of the INCLINE TRAINER.	Clean the INCLINE TRAINER.	Check the walking belt for proper tension and alignment.	Remove the motor hood and vacuum the motor compartment.	Check the motor belt for cracks and other wear.	Lubricate the walking platform.
Week 1	/ /	/ /	/ /			
Week 2	/ /	/ /	/ /			
Week 3	/ /	/ /	/ /			
Week 4	/ /	/ /	/ /	/ /	/ /	/ /
Week 5	/ /	/ /	/ /			
Week 6	/ /	/ /	/ /			
Week 7	/ /	/ /	/ /			
Week 8	/ /	/ /	/ /	/ /	/ /	/ /
Week 9	/ /	/ /	/ /			
Week 10	/ /	/ /	/ /			
Week 11	/ /	/ /	/ /			
Week 12	/ /	/ /	/ /			
Week 13	/ /	/ /	/ /	/ /	/ /	/ /
Week 14	/ /	/ /	/ /			
Week 15	/ /	/ /	/ /			
Week 16	/ /	/ /	/ /			
Week 17	/ /	/ /	/ /	/ /	/ /	/ /
Week 18	/ /	/ /	/ /			
Week 19	/ /	/ /	/ /			
Week 20	/ /	/ /	/ /			
Week 21	/ /	/ /	/ /	/ /	/ /	/ /
Week 22	/ /	/ /	/ /			
Week 23	/ /	/ /	/ /			
Week 24	/ /	/ /	/ /			
Week 25	/ /	/ /	/ /			
Week 26	/ /	/ /	/ /	/ /	/ /	/ /

Walking Platform Turned/Replaced	/ /	/ /	Walking Belt Replaced	/ /
----------------------------------	-----	-----	-----------------------	-----

SIX-MONTH PREVENTIVE MAINTENANCE RECORD

Photocopy this form and use it to record the preventive maintenance performed on the INCLINE TRAINER. Each copy of the form can be used for six months (26 weeks). When maintenance is performed, write the date in the appropriate spaces. **Make sure to perform each maintenance procedure as described on pages 27 and 28. If the procedures are not performed as described, components may wear excessively, and the INCLINE TRAINER may be damaged.**

	Weekly Maintenance			Monthly Maintenance		
	Inspect and tighten all external parts of the INCLINE TRAINER.	Clean the INCLINE TRAINER.	Check the walking belt for proper tension and alignment.	Remove the motor hood and vacuum the motor compartment.	Check the motor belt for cracks and other wear.	Lubricate the walking platform.
Week 1	/ /	/ /	/ /			
Week 2	/ /	/ /	/ /			
Week 3	/ /	/ /	/ /			
Week 4	/ /	/ /	/ /	/ /	/ /	/ /
Week 5	/ /	/ /	/ /			
Week 6	/ /	/ /	/ /			
Week 7	/ /	/ /	/ /			
Week 8	/ /	/ /	/ /	/ /	/ /	/ /
Week 9	/ /	/ /	/ /			
Week 10	/ /	/ /	/ /			
Week 11	/ /	/ /	/ /			
Week 12	/ /	/ /	/ /			
Week 13	/ /	/ /	/ /	/ /	/ /	/ /
Week 14	/ /	/ /	/ /			
Week 15	/ /	/ /	/ /			
Week 16	/ /	/ /	/ /			
Week 17	/ /	/ /	/ /	/ /	/ /	/ /
Week 18	/ /	/ /	/ /			
Week 19	/ /	/ /	/ /			
Week 20	/ /	/ /	/ /			
Week 21	/ /	/ /	/ /	/ /	/ /	/ /
Week 22	/ /	/ /	/ /			
Week 23	/ /	/ /	/ /			
Week 24	/ /	/ /	/ /			
Week 25	/ /	/ /	/ /			
Week 26	/ /	/ /	/ /	/ /	/ /	/ /

Walking Platform Turned/Replaced	/ /	/ /	Walking Belt Replaced	/ /
----------------------------------	-----	-----	-----------------------	-----

TROUBLESHOOTING

Most INCLINE TRAINER problems can be solved by following the steps outlined in this section. Find any symptoms that apply, and follow the steps listed. If further assistance is needed, please contact your distributor.

1. SYMPTOM: THE POWER DOES NOT TURN ON

- a. Make sure that the power cord is plugged into a properly grounded outlet. (See page 10.)
- b. Make sure that the key is inserted into the console.
- c. Check the on/off circuit breaker located on the INCLINE TRAINER near the power cord. Make sure that the on/off circuit breaker is switched to the on position.

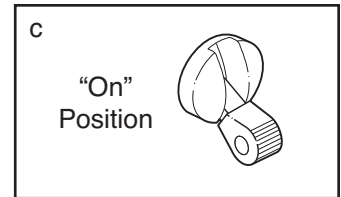

2. SYMPTOM: THE POWER TURNS OFF DURING USE

- a. Check the on/off circuit breaker located on the INCLINE TRAINER near the power cord. (See drawing 1. c. above.) Make sure that the on/off circuit breaker is switched to the on position.
- b. Make sure that the power cord is plugged in.
- c. Remove the key from the console. Reinsert the key into the console.
- d. Check the walking belt and the walking platform for excessive wear. Replace the walking belt or the walking platform if necessary.
- e. If the power still turns off during use, please contact your distributor.

3. SYMPTOM: THE WALKING BELT SLOWS WHEN WALKED ON

- a. If the walking belt is overtightened, performance may decrease and the walking belt may be damaged. If the walking belt is properly tightened, you should be able to lift each side of the walking belt 2.5 to 5 cm (1 to 2 in.) off the walking platform. **If adjustments need to be made, first remove the key and unplug the power cord.** Using the included hex key, turn both roller adjustment bolts counterclockwise 1/4 of a turn. Be careful to keep the walking belt centred. Plug in the power cord, insert the key, and use the INCLINE TRAINER for a few minutes. Repeat until the walking belt is properly tightened. Note: To tighten the walking belt, see step 7. c. on page 32.

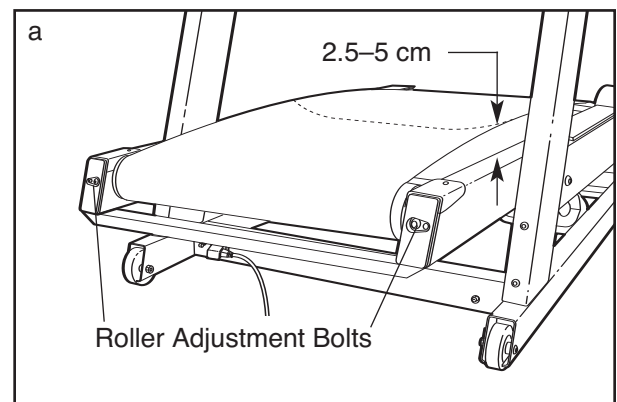

- b. Make sure that the walking platform is properly lubricated. (See step 4 of MONTHLY MAINTENANCE on page 27.)
- c. If the walking belt still slows when walked on, please contact your distributor.

4. SYMPTOM: THE WALKING BELT IS OFF-CENTRE OR SLIPS WHEN WALKED ON

a. **If the walking belt has shifted to the left: Remove the key and unplug the power cord.** Using the included hex key, turn the roller adjustment bolts in the directions shown, 1/4 of a turn each. Be careful not to overtighten the walking belt. Plug in the power cord, insert the key and use the INCLINE TRAINER for a few minutes. Repeat until the walking belt is centred.

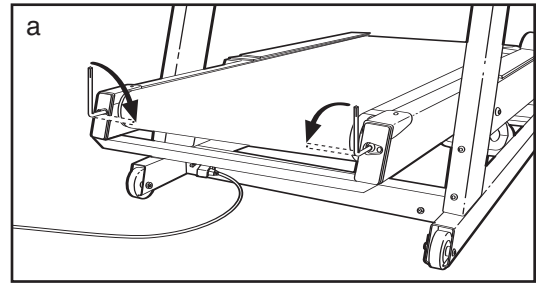

b. **If the walking belt has shifted to the right: Remove the key and unplug the power cord.** Using the included hex key, turn the roller adjustment bolts in the directions shown, 1/4 of a turn each. Be careful not to overtighten the walking belt. Plug in the power cord, insert the key and use the INCLINE TRAINER for a few minutes. Repeat until the walking belt is centred.

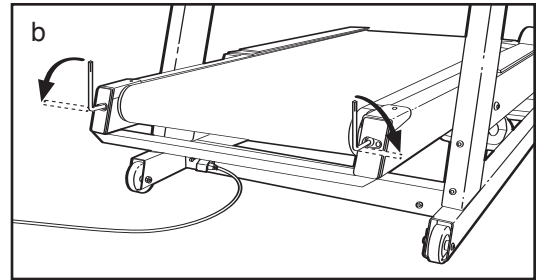

c. **If the walking belt slips when walked on: Remove the key and unplug the power cord.** Using the included hex key, turn both roller adjustment bolts clockwise 1/4 of a turn. When the walking belt is properly tightened, you should be able to lift each side of the walking belt 2.5 to 5 cm (1 to 2 in.) off the walking platform. The centre of the walking belt should just touch the walking platform. Make sure to keep the walking belt centred. Plug in the power cord, insert the key and run the INCLINE TRAINER for a few minutes. Repeat until the walking belt is properly tightened. Note: As you tighten the roller adjustment bolts, the front roller will move. **If the front roller stops moving, do not further tighten the roller adjustment bolts; contact your distributor.**

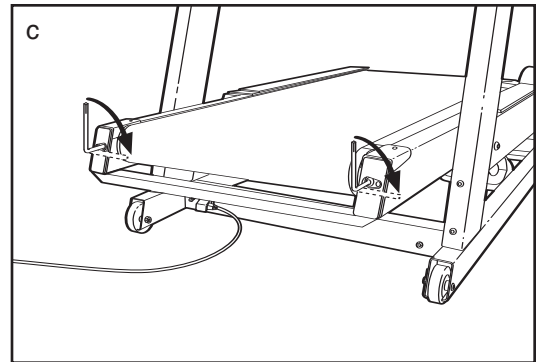

5. SYMPTOM: THE WALKING BELT STOPS OR THE INCLINE CANNOT BE ADJUSTED EVEN THOUGH THE CONSOLE REMAINS LIT

a. This indicates that a controller error may have occurred. To correct the problem, see step 8 on page 22.

6. SYMPTOM: THE INCLINE SYSTEM DOES NOT FUNCTION PROPERLY OR THE INCLINE SYSTEM DOES NOT APPEAR TO BE AT THE INCLINE LEVEL SHOWN IN THE MAIN DISPLAY

a. The incline system may need to be calibrated. To initiate the calibration routine, hold down the SPEED + button and the SPEED – button simultaneously for three seconds. During the calibration routine, the INCLINE TRAINER will automatically travel to the lowest incline setting and then return to level.

b. If the incline system still does not function properly, contact your distributor.

7. SYMPTOM: THE WORDS LUBRICATE DECK APPEAR EVERY FEW MINUTES IN THE MAIN DISPLAY

a. If the words LUBRICATE DECK appear in the main display, the walking platform should be checked for adequate lubricant. Follow the instructions in step 4 on page 27 to lubricate the walking platform if necessary. After you have lubricated the walking platform, see HOW TO RESET THE LUBE REMINDER on page 24. **If this is not done, the words LUBRICATE DECK will continue to appear.**

EXERCISE GUIDELINES

FACTORS IN A SENSIBLE DIET

- Choose high-fiber, low-fat, and low-sugar foods: fruits, vegetables, and whole grains.
- Eat at least five servings of fruits and vegetables daily.
- Reduce red meat consumption; eat lean meat, white meat, and fish.
- Choose healthful snacks; bring healthful foods with you to work or in the car.
- Eat regular meals or mini-meals. Control your portion size—don't binge or overeat. Eat slowly.
- Reduce fast food and pre-packaged meals.
- Pay attention to fat content and calories.
- Limit alcoholic beverages and caffeine.
- Drink at least eight to ten glasses of water daily.

EXERCISE STEPS

The following nine steps for designing your exercise program were developed by exercise physiologists at NordicTrack. The actual exercise you perform is only a part of a safe and effective training program. There are many other aspects to developing a life-long commitment to physical fitness.

1 Consult your physician before beginning any exercise program.

A medical examination or consultation with your physician is essential.

2 Establish personal fitness goals.

Set attainable, realistic goals. Reward yourself when you meet your goals. Remember, your goals should act as a guide for your workout program.

3 Determine your target heart rate.

Your *target heart rate* (THR), is the rate at which you would like your heart to work during aerobic exercise. It is expressed as a percentage of your *maximum heart rate* (MHR). MHR is the maximum number of times that your heart can pump during one minute. To determine your approximate MHR, subtract your age (in years) from 220. This is only an estimation of your MHR—only clinical stress testing can provide an actual MHR reading.

Once you have determined your MHR, you can establish your target heart rate zone. Beginning exercisers may wish to start at 60 to 70 percent of their MHR. This level is called the *Health* level. Exercise at 70 to 85 percent of your MHR for the optimal training, aerobic, or cardiovascular level—the *Fitness* level. Advanced exercisers, or those wishing to do sports, athletic conditioning, or interval training workouts should exercise at 80 to 85 percent of the MHR for short periods of time. The chart below shows Target Heart Rate Zones for Health, Fitness, and Advanced exercisers.

Be sure to check your heart rate at least twice during an aerobic conditioning session. First, check your heart rate five minutes into your workout to be sure that you are at the proper intensity. Then, check it again near the end of your workout to verify that you have maintained your target heart rate for the recommended period of time.

TARGET HEART RATE ZONES

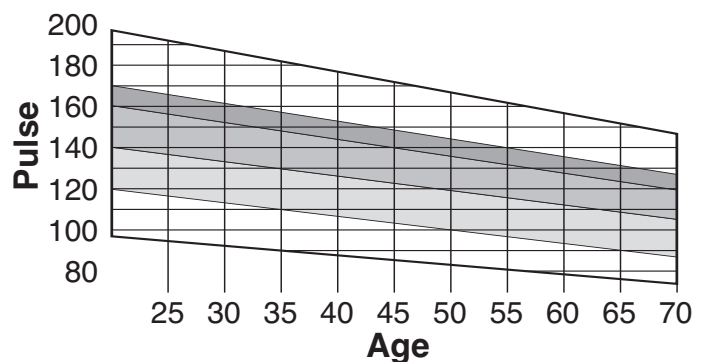

Health	Fitness	Advanced
Beginner, low-intensity + long duration = fat burning	Optimal training, aerobic or cardiovascular	Sports, athletic conditioning, interval training

WEIGHT LOSS TIPS

At least four, 30-minute workouts per week, along with a reduced-calorie diet, are recommended if you are trying to lose weight. However, be sure to stay within your target heart rate zone and exercise a maximum of 5 days per week for 60 minutes per workout.

Good posture is the key to safe, comfortable workouts. Keep your chin up and your head facing forward. Align your head and shoulders with your hips. Avoid leaning forward. Keep your back straight.

4 Warm up before you begin.

A warm-up routine prepares your body and mind for vigorous exercise. It also helps provide insurance against injury and soreness. Warm up with two to five minutes of slow exercise, at minimal intensity.

5 Stretch after your warm-up.

A pliable, well-stretched muscle is less susceptible to injury. Perform the recommended stretches on a smooth, flat surface.

The correct form for several stretches is described below (see the drawings at the right). Be sure to move slowly as you stretch—never bounce.

1. Toe Touch Stretch—Sit with your knees bent slightly and slowly bend forward from your hips. Allow your back and shoulders to relax as you reach toward your toes as far as possible. Hold for 15 to 30 seconds, then relax. Repeat 3 times. Stretches: Hamstrings, back of knees, and back.

2. Calf/Achilles Stretch—With one leg in front of the other, reach forward and place your hands against a wall. Keep your back leg straight and your back foot flat on the floor. Bend your front leg, lean forward, and move your hips toward the wall. Hold for 15 to 30 seconds, then relax. Repeat 3 times for each leg. To cause further stretching of the achilles tendons, bend your back leg as well. Stretches: Calves, achilles tendons, and ankles.

3. Hamstring Stretch—Sit with one leg extended. Bring the sole of the opposite foot toward you and rest it against the inner thigh of your extended leg. Reach toward your toes as far as possible. Hold for 15 to 30 seconds, then relax. Repeat 3 times for both legs. Stretches: Hamstrings, lower back, and groin.

4. Inner Thigh Stretch—Sit with the soles of your feet together and your knees outward. Pull your feet toward your groin area as far as possible. Hold for 15 to 30 seconds, then relax. Repeat 3 times. Stretches: Quadriceps and hip muscles.

5. Quadriceps Stretch—With one hand against a wall for balance, reach back and grasp one foot with your other hand. Bring your heel as close to your buttocks as possible. Hold for 15 to 30 seconds, then relax. Repeat 3 times for each leg. Stretches: Quadriceps and hip muscles.

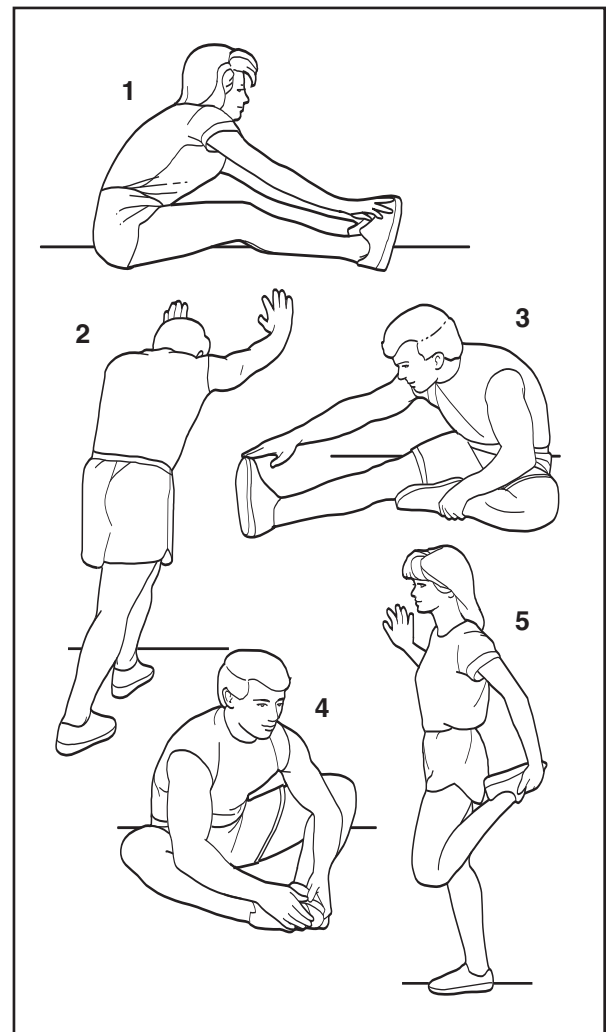

BENEFITS OF AEROBIC EXERCISE

- Effective weight loss and management
- Added protection from heart disease
- Increased strength and health of bones
- Higher levels of energy for greater productivity during the day
- Healthy stress relief from a pressure-packed day
- Greater intellectual capacity and productivity

6 Get FIT with NordicTrack

Effective aerobic exercise has three major parts: *frequency*, *intensity*, and *time*. The acronym "FIT" may help you to remember these three parts:

F "F" stands for the frequency of your workouts. Three to five workouts per week are recommended. Exercise at least four times a week for weight loss.

I "I" refers to the intensity of your workout. Check your heart rate at least twice during your aerobic exercise session: once during the session and once again at the end. Maintain a workout intensity level within your Target Heart Rate Zone. You can measure your heart rate using the handgrip pulse sensor or the method described below:

1. Lower your wrist below your heart level. This will make your heart rate stronger and easier to feel.

2. Using the tips of the index and middle fingers of your right hand, touch your left wrist, one-fourth inch from your wrist joint, at the base of your thumb.

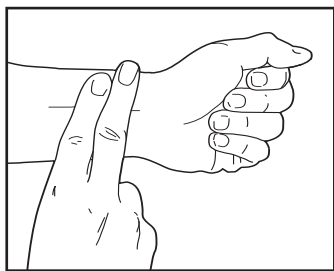

3. Apply minimal pressure with both fingers—let the beat come to your fingers. If you can't find your pulse, use the opposite wrist and hand.

T "T" is for the time or duration of your workout. Beginning exercisers may wish to start with 5 to 10 minutes of aerobic activity. Those in average physical condition should exercise for 20 to 30 minutes. Highly fit people, or people who want to lose weight, should exercise for 30 to 60 minutes. The key is to maintain your target heart rate for the duration of the workout period.

Remember to take it slowly. Fitness is a lifelong commitment. If you can't go the full 20 minutes from the start, which is common, try to exercise for five minutes at a time, a couple of times a day. Recent research indicates that several short workouts in one day can also provide fitness benefits. Gradually, your stamina will increase and it will become easier to exercise for longer periods of time.

7 Cool down after aerobic exercise.

Keep moving! It is important that you cool down properly to allow your heart rate to decrease slowly after it has been elevated. This helps the blood flow from your extremities back to your heart. Keep your legs moving on the INCLINE TRAINER at a slower pace for at least five minutes following the aerobic phase.

8 Stretch again at the end of your exercise session.

Stretching after exercise reduces muscle soreness. See step 5 on page 34.

9 Participate in strength training.

"Balanced fitness, including both strength training and aerobic exercise, can do more to ensure a happy life than just about anything else known to medical science today."

—Kenneth Cooper, M.D., M.P.H., founder of The Cooper Institute For Aerobic Research, Dallas, Texas.

A strength-training program increases your lean muscle mass. Lean muscle mass aids in burning body fat. With additional muscle mass and strength, you will receive the full benefits of an exercise program. You will also be less prone to injuries during the aerobic phase of your workout.

WORKOUT TIPS

Full-body conditioning helps take care of many of life's aches and pains. However, it takes time for your body to adapt to any new routine. Below are some tips that will help ease you into your new NordicTrack routine.

- Begin and end each exercise session with the stretches on page 36. Stretch in a smooth, controlled manner. Hold each stretch for 15 to 30 seconds. You may experience some initial muscle soreness and discomfort as a result of exercising inactive or poorly stretched muscles. For maximum benefit, a stretching routine must be performed every day.
- Be aware of your body's signals and react to them accordingly. At your correct exercise intensity, you should be able to whistle or maintain a normal conversation. If during exercise you feel tired, light-headed, dizzy, or nauseated, stop exercising immediately and consult your physician. Your heart rate may also be affected by such things as stress, caffeine, nicotine, or prescription drugs.

WORKOUT PROGRAMS

The *Health* level typically lasts four to six weeks. At this level you should be concerned with slowly improving your fitness level and endurance.

Take it slowly. Set mini-goals for yourself. You may want to begin your fitness routine with three or four short, 5- or 10-minute workouts in a day.

Move on to the *Fitness* Level only when you feel ready and your heart rate has moved below your target heart rate zone.

The *Fitness* level usually lasts 12 to 20 weeks. (It may last longer, depending on your fitness goals.) At this level you should strive to achieve your fitness goals.

Set realistic short- and long-term goals for yourself. Frequently re-evaluate your fitness goals and reward yourself as you are successful.

Move on to the *Advanced* Level when you have reached your fitness goals and your heart rate has moved below your target heart rate zone.

Work out at the *Advanced* level once you have reached your desired fitness goals. It is intended to be a maintenance program and should continue on a regular, long-term basis.

You may wish to add *Interval Training* to your maintenance program as well. Interval training will add variety to your workout routine and further condition your cardiovascular system. Interval training has been shown to promote higher levels of aerobic conditioning. It consists of spurts of high-intensity activity followed by active rest periods of exercise at a lower intensity. For example, a one-minute spurt of high-resistance, fast exercise is followed by a two- to three-minute active rest period of low-resistance, slow exercise. The duration of these periods should be based more on how you feel rather than time. A sequence such as this should be repeated 5 to 20 times during your workout session.

Heart Rate Intensity								
HEART RATE INTENSITY	Age	20	30	40	50	60	70	80
60% - 70% HEALTH	b.p.m.	120-140	114-133	108-126	102-119	96-112	90-105	84-98
70% - 85% FITNESS	b.p.m.	140-170	133-162	126-153	119-145	112-136	105-128	98-119
80% - 85% ADVANCED	b.p.m.	160-170	152-162	144-153	136-145	128-136	120-128	112-119

To locate the parts listed below, see the EXPLODED DRAWING on pages 39 to 41.

Key No.	Qty.	Description	Key No.	Qty.	Description
1	1	Left Foot Pad	51	2	Base Pad
2	1	Hood	52	1	Base Frame
3	1	Rear Endcap (Left)	53	2	Incline Motor Bolt (Lower)
4	1	Drive Roller	54	2	Caution Decal
5	2	Rear Roller Guard (Right)	55	1	Roller Pulley
6	25	Guard/Endcap Screw	56	2	Belt Guide Bolt
7	4	Incline Motor Bushing	57	1	Power Supply Box
8	4	Platform Screw (Rear)	58	1	High Voltage Decal
9	2	Incline Motor Bolt	59	1	Electronics Cover
10	1	Cup Holder	60	2	Frame Pivot Bolt
11	2	Mid Frame Endcap	61	2	Frame Pivot Bushing
12	1	Power Cord Bracket	62	2	Frame Spacer
13	4	Roller Guard Cage Nut (Front)	63	1	J-Bolt Caution Decal
14	2	Belt Guide	64	1	Front Endcap (Right)
15	33	Bracket Screw	65	8	Handrail Cover Cage Nut
16	2	Front Roller Adj. Bolt	66	2	Rear Leveling Leg
17	2	Front Roller Adj. Washer	67	4	Motor Bolt
18	1	Front Endcap (Left)	68	4	Motor Bushing
19	1	Right Foot Pad	69	1	Drive Motor
20	1	Walking Belt	70	4	Motor Nut
21	1	Walking Platform	71	1	Hazardous Voltage Decal
22	1	Lift Frame	72	1	Motor Isolator
23	6	Incline Motor Nut	73	5	Hood Screw
24	4	Resistor Washer	74	2	Sensor Bracket Screw
25	2	Resistor Nut	75	1	Sensor Bracket
26	1	Controller Box	76	1	Speed Sensor
27	1	Torsion Bar	77	1	Speed Disk
28	2	Resistor Screw	78	1	Front Roller
29	2	Incline Motor	79	1	Motor Belt
30	1	Cord Caution Decal	80	1	Idler Pulley Bolt
31	3	Speed Disk Screw	81	1	Idler Pulley
32	2	Ferrite Box	82	4	Incline Motor Washer
33	1	TV Cable (Long)	83	1	Motor Pulley
34	1	Strain Relief Bracket	84	1	Idler Pivot Bolt
35	4	Access Cover Screw	85	1	Idler Arm
36	2	Receptacle Bolt	86	1	J-Bolt
37	1	TV Cable (Short)	87	4	Wire Tie Clip
38	1	Wiring Plate (Left)	88	1	Green Ground Wire (12")
39	4	Wheel Bolt	89	1	Console Assembly
40	4	Wheel	90	1	Key/Clip
41	2	Chest Pulse Foam	91	8	Upright Cap Screw
42	1	Jack	92	2	Upright Cap
43	1	Power Cord	93	4	Handrail Bolt
44	1	Power Cord Receptacle	94	1	Handrail
45	2	Receptacle Nut	95	2	Handrail Endcap
46	1	On/Off Circuit Breaker	96	1	Left Upright
47	2	Incline Motor Spacer	97	4	Pulse Sensor
48	1	Wiring Plate (Right)	98	26	Small Screw
49	1	Power Wire Harness (Right)	99	4	Pulse Sensor Screw
50	4	Base Pad Screw	100	2	Pulse Housing Screw

Key No.	Qty.	Description	Key No.	Qty.	Description
101	1	Pulse Sensor Housing	150	1	Resistor Wire
102	1	Pulse Wire	151	2	Motor Insert
103	1	Pulse Sensor	152	5	Rear Base Inserts
104	5	Releasable Wire Tie	153	2	Fastener Receptacle
105	1	Right Upright Wire Harness (Upper)	154	2	Plastic Spacer
106	8	Upright Bolt	155	2	Incline Pivot Bushing
107	1	Right Upright	156	2	Incline Bushing (Short)
108	1	Hex Key (5/16")	157	2	Incline Bushing (Long)
109	1	Hex Key (7/32")	158	1	Cable Bushing
110	1	Hex Key (5/32")	159	2	Fastener Spring
111	18	Cable Tie	160	2	Fastener Retainer
112	1	Hex Key (1/8")	161	2	Roller Guard Screw
113	4	Pulse Sensor Base	162	2	On/Off Switch Screw
114	4	Incline Bolt	163	6	Console Screw
115	2	Electronics Cover Fastener	164	2	Belt Guide Lock Washer
116	1	Rear Endcap (Right)	165	1	Incline Link Bar
117	2	Torsion Bar Bushing (Lower)	166	2	Nylon Washer
118	4	Pulley Screw	167	1	Access Cover
119	4	Base Pad U-Nut	168	1	Large Cover Plate
120	2	Small Incline Bushing	169	1	J-bolt Nut
121	2	Front Roller Guard	170	2	Incline Motor Cover (Top)
122	2	Platform Screw (Front)	171	1	Hood Cover
123	2	Front Isolator	172	4	Wheel Nut
124	1	Left Pulley Endcap	173	4	Motor Washer
125	4	1 1/4" Bumper	174	2	Torsion Bar Bolt
126	1	Flywheel	#	2	Sensor Nut
127	4	Controller Box Screw	#	1	97" Power Board Wire
128	1	Incline Wire Harness (Short)	#	1	110" Power Board Wire
129	2	Spacer	#	1	4" Black Wire, 2F
130	2	Foam Grip	#	1	4" White Wire, M/F
131	1	Left Upright Wire Harness (105")	#	1	10" White Wire. 2F
132	1	Static Decal	#	1	22" White Wire. 2F
133	2	Incline Motor Cover (Bottom)	#	1	20" White Wire. 2F
134	2	Black Torsion Bar Washer	#	1	7" Green Wire, M/Ring
135	1	Foam Pad	#	1	12" Green Wire, F/R
136	1	Resistor	#	1	12" Green Wire, 2 Ring
137	6	5/16" Flat Washer	#	1	12" Wire Harness, 6 Wire
138	6	1/2" Nylon Washer	#	1	20" Wire Harness, 3 Wire
139	1	Cup Holder Pad	#	1	50" Wire Harness, 3 Wire
140	1	Accessory Holder Pad	#	1	76"Wire Harness, 15 Wire
141	1	Warning Decal	#	1	77" Wire Harness, 4 Wire
142	1	Accessory Holder	#	1	20" Controller Wire
143	2	Sensor Screw	#	1	User's Manual
144	1	Filter Wire			
145	1	Power Wire Harness (Left)			
146	1	Roll Pin			
147	2	Front Isolator Nut			
148	50	Small Insert			
149	2	Pulse Housing Clip			

* Includes all parts shown in the box

These parts are not illustrated

Specifications are subject to change without notice.

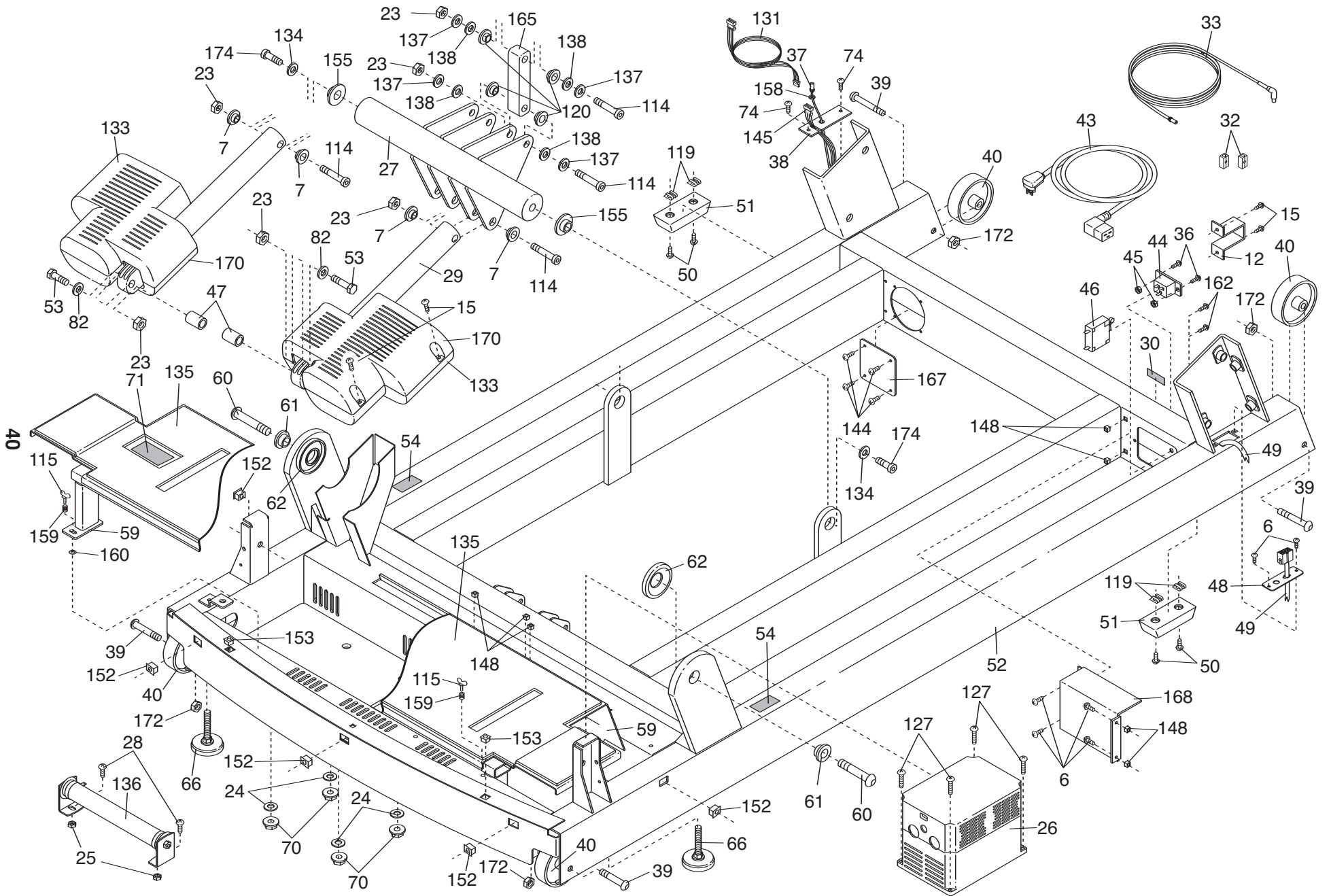

HOW TO ORDER REPLACEMENT PARTS

To order replacement parts, please contact your distributor. Be prepared to give the following information:

- The MODEL NUMBER OF THE PRODUCT (see the front cover of this manual)
- The NAME OF THE PRODUCT (NordicTrack® 9800 INCLINE TRAINER)
- The SERIAL NUMBER OF THE PRODUCT (see the front cover of this manual for the location)
- The KEY NUMBER and DESCRIPTION OF THE PART(S) (see the PART LIST and the EXPLODED DRAWING on pages 37 to 41)



FreeMotion Fitness, Inc. • 1096 Elkton, Suite 600 • Colorado Springs, CO 80907