

PRO-FORM[®]

SpaceSaver DX

Model No. PFEL77908.2

Serial No. _____

Write the serial number in the space above for reference.

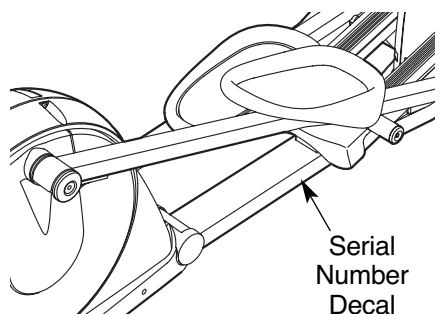

USER'S MANUAL

QUESTIONS?

As a manufacturer, we are committed to providing complete customer satisfaction. If you have questions, or if parts are missing, **PLEASE DO NOT CONTACT THE STORE;** please contact Customer Care.

IMPORTANT: You must note the product model number and serial number (see the drawing above) before contacting us:

CALL TOLL-FREE:

1-888-533-1333

Mon.–Fri. 6 a.m.–6 p.m. MST

Sat. 8 a.m.–4 p.m. MST

ON THE WEB:

www.proformservice.com

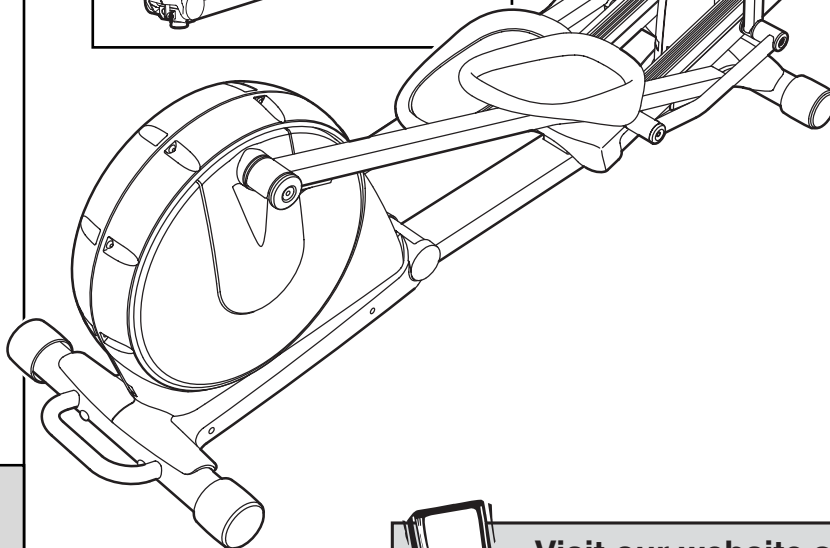
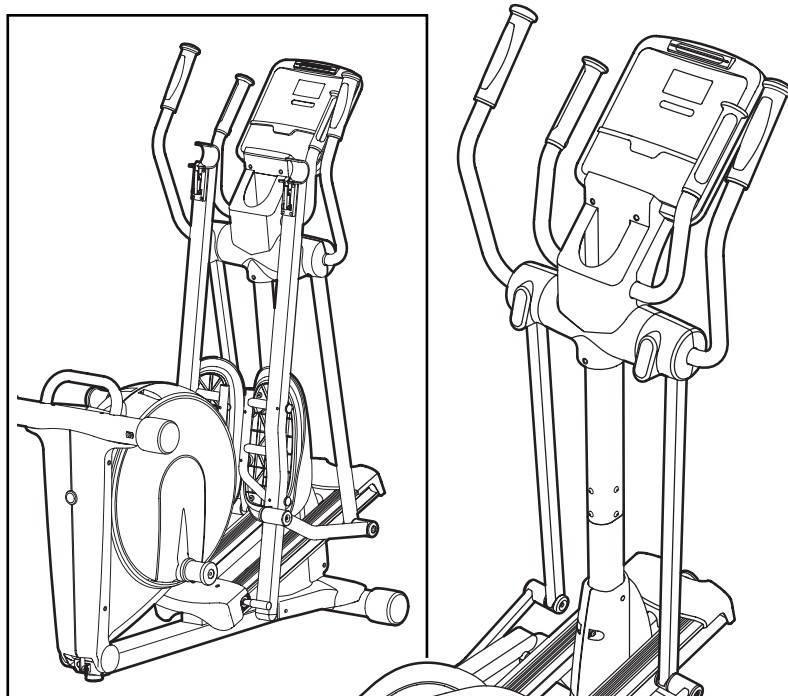

CAUTION

Read all precautions and instructions in this manual before using this equipment. Keep this manual for future reference.



Visit our website at

www.proform.com

new products, prizes,
fitness tips, and much more!

TABLE OF CONTENTS

WARNING DECAL PLACEMENT2
IMPORTANT PRECAUTIONS3
BEFORE YOU BEGIN4
ASSEMBLY5
HOW TO USE THE ELLIPTICAL EXERCISER12
MAINTENANCE AND TROUBLESHOOTING20
EXERCISE GUIDELINES21
PART LIST24
EXPLODED DRAWING26
ORDERING REPLACEMENT PARTSBack Cover
LIMITED WARRANTYBack Cover

WARNING DECAL PLACEMENT

The warning decals shown here have been applied in the locations shown. **If a decal is missing or illegible, call the telephone number on the front cover of this manual and request a free replacement decal. Apply the decal in the location shown.** Note: The decals may not be shown at actual size.

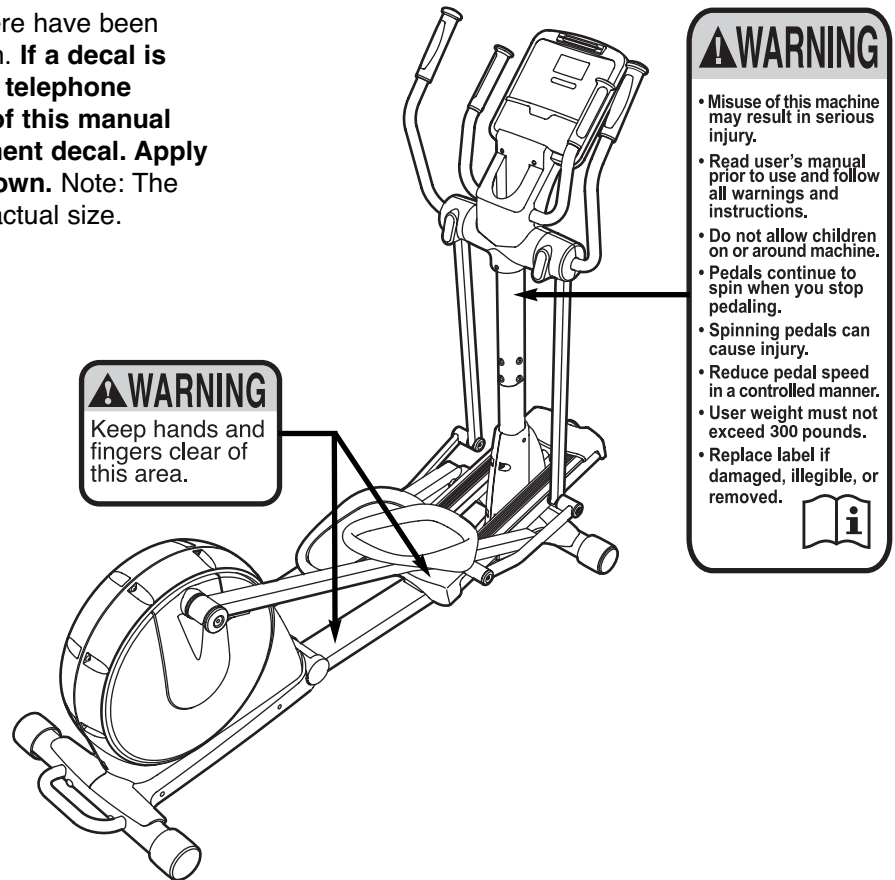

IMPORTANT PRECAUTIONS

⚠️ WARNING: To reduce the risk of serious injury, read all important precautions and instructions in this manual and all warnings on your elliptical exerciser before using your elliptical exerciser. ICON assumes no responsibility for personal injury or property damage sustained by or through the use of this product.

1. Before beginning any exercise program, consult your physician. This is especially important for persons over the age of 35 or persons with pre-existing health problems.
2. It is the responsibility of the owner to ensure that all users of the elliptical exerciser are adequately informed of all precautions.
3. Your elliptical exerciser is intended for home use only. Do not use your elliptical exerciser in a commercial, rental, or institutional setting.
4. Keep your elliptical exerciser indoors, away from moisture and dust. Place your elliptical exerciser on a level surface, with a mat beneath it to protect the floor or carpet. Make sure that there is enough clearance around your elliptical exerciser to mount, dismount, and use it.
5. Inspect and properly tighten all parts regularly. Replace any worn parts immediately.
6. Keep children under age 12 and pets away from your elliptical exerciser at all times.
7. Your elliptical exerciser should not be used by persons weighing more than 300 lbs. (136 kg).
8. Wear appropriate exercise clothes when exercising; do not wear loose clothes that could become caught on your elliptical exerciser. Always wear athletic shoes for foot protection.
9. Hold the handgrip pulse sensor or the upper body arms when mounting, dismounting, or using your elliptical exerciser.
10. Keep your back straight while using your elliptical exerciser; do not arch your back.
11. The pulse sensor is not a medical device. Various factors, including the user's movement, may affect the accuracy of heart rate readings. The pulse sensor is intended only as an exercise aid in determining heart rate trends in general.
12. When you stop exercising, allow the pedals to slowly come to a stop.
13. If you feel pain or dizziness while exercising, stop immediately and cool down.
14. Use your elliptical exerciser only as described in this manual.

BEFORE YOU BEGIN

Thank you for purchasing the revolutionary PROFORM® SPACESAVER DX elliptical exerciser. The SPACESAVER DX elliptical exerciser provides a wide array of features designed to make your workouts at home more effective and enjoyable—and when you're not exercising, the unique elliptical exerciser can be folded out of the way.

For your benefit, read this manual carefully before you use the elliptical exerciser. If you have questions after reading this manual, please see the front cover of this manual. To help us assist you, note the

product model number and serial number before contacting us. The model number and the location of the serial number decal are shown on the front cover of this manual.

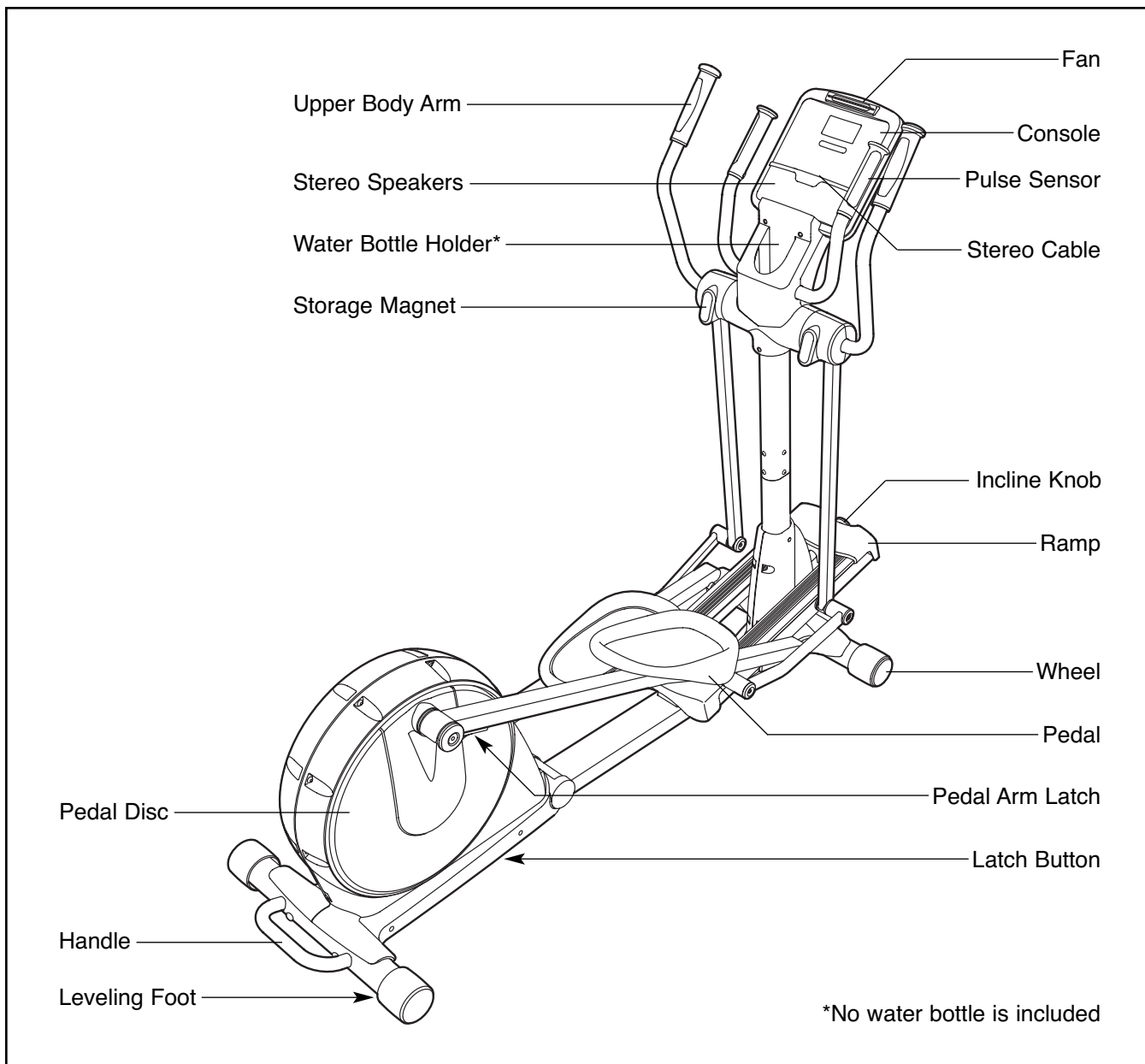

To avoid a registration fee for any service needed under warranty, you must register the elliptical exerciser at www.proformservice.com/registration.

Before reading further, please familiarize yourself with the parts that are labeled in the drawing below.

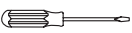

ASSEMBLY

To hire an authorized service technician to assemble the elliptical exerciser, call 1-800-445-2480.

Assembly requires two persons. Place all parts of the elliptical exerciser in a cleared area and remove the packing materials. Do not dispose of the packing materials until assembly is completed. **In addition to the included hex keys, assembly requires a Phillips screwdriver** , **an adjustable wrench** , and **a rubber mallet** .

As you assemble the elliptical exerciser, use the drawings below to identify small parts. The number in parentheses below each drawing is the key number of the part, from the PART LIST near the end of this manual. The number following the parentheses is the quantity needed for assembly. **Note: Some small parts may have been pre-assembled. If a part is not in the hardware kit, check to see if it has been pre-assembled.**

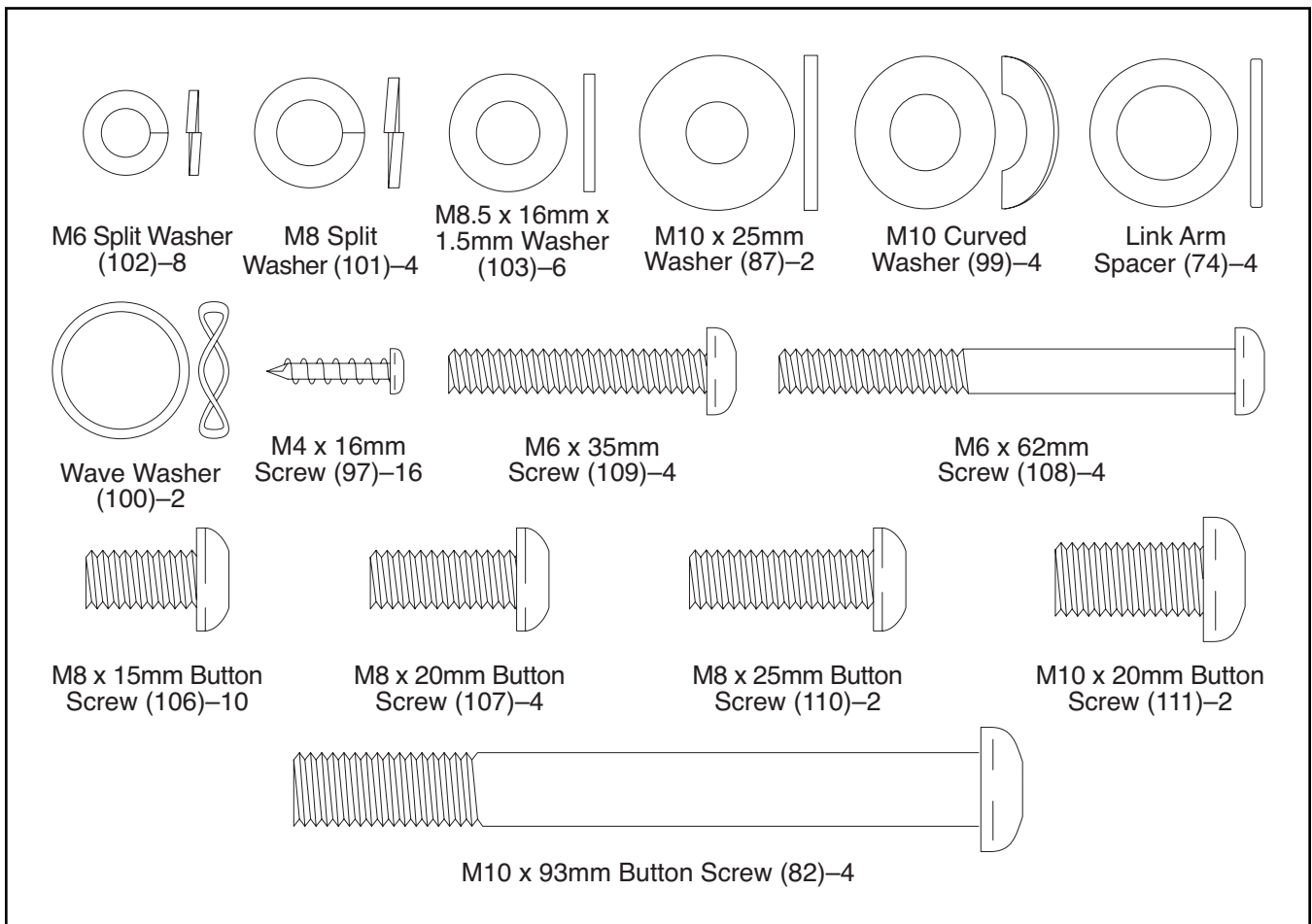

1.

To make assembly easier, read the information on page 5 before you begin assembling the elliptical exerciser.

See **HOW TO FOLD AND UNFOLD THE ELLIPTICAL EXERCISER** on page 12 and unfold the elliptical exerciser.

While another person lifts the front of the Frame (1), attach the Front Stabilizer (4) to the Frame with two M10 x 93mm Button Screws (82) and two M10 Curved Washers (99).

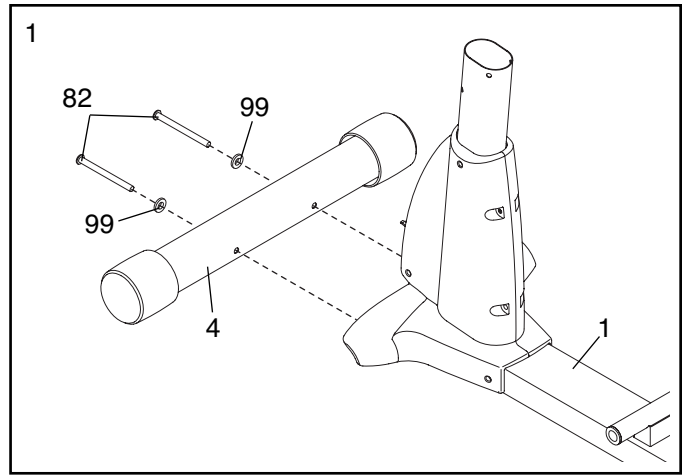

2. While another person lifts the Folding Frame (2), attach the Rear Stabilizer (3) to the Folding Frame with two M10 x 93mm Button Screws (82) and two M10 Curved Washers (99).

Next, tighten the Center Foot (95) into the Frame (1).

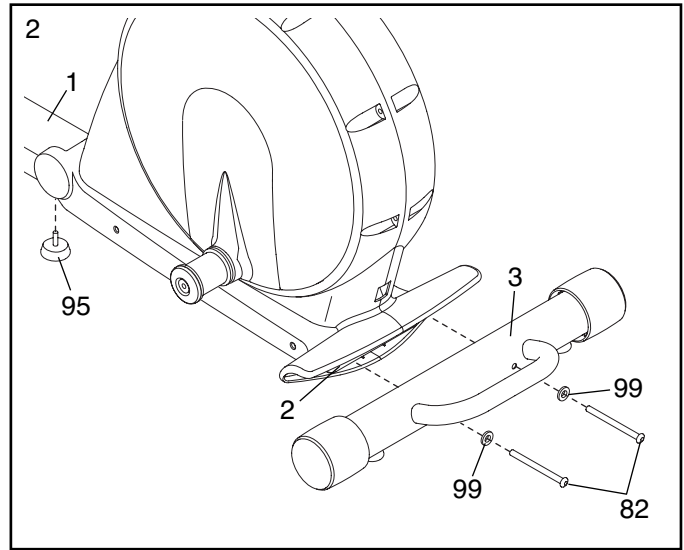

3. Attach the Front Ramp Cover (6) to the Ramp (5) with four M4 x 16mm Screws (97).

Slide an M10 x 25mm Washer (87) onto an M10 x 20mm Button Screw (111). Tighten the Button Screw into one end of the Ramp Axle (72). Apply a small amount of the included grease to the Ramp Axle.

Orient the Ramp (5) as shown. Align the lower end of the Ramp with the welded tube on the Frame (1). Insert the Ramp Axle (72) into the Ramp and the welded tube. Then, pull the Ramp Knob (9), lower the Ramp, and engage the Ramp Pin (62) into one of the three adjustment holes in the front of the Frame.

Slide an M10 x 25mm Washer (87) onto an M10 x 20mm Button Screw (111). Tighten the Button Screw into the open end of the Ramp Axle (72).

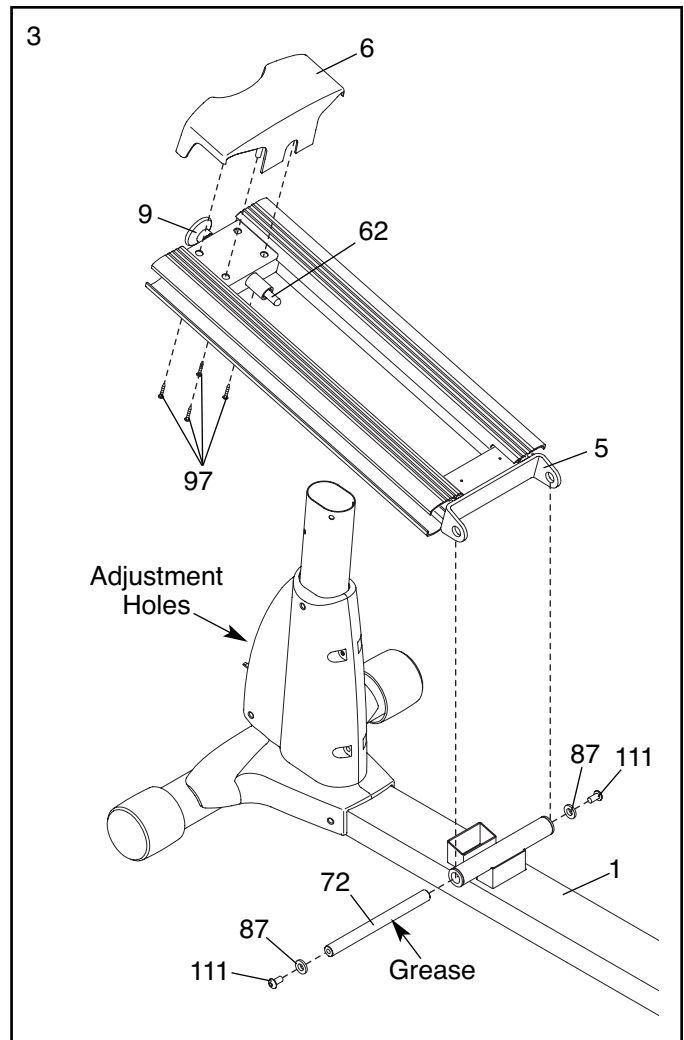

4. Identify the Left Pedal (34) and the Left Pedal Arm (32), which are marked with stickers.

Attach the Left Pedal (34) to the Left Pedal Arm (32) with two M6 x 62mm Screws (108), two M6 x 35mm Screws (109), and four M6 Split Washers (102).

Attach the Right Pedal (not shown) to the Right Pedal Arm (not shown) in the same way.

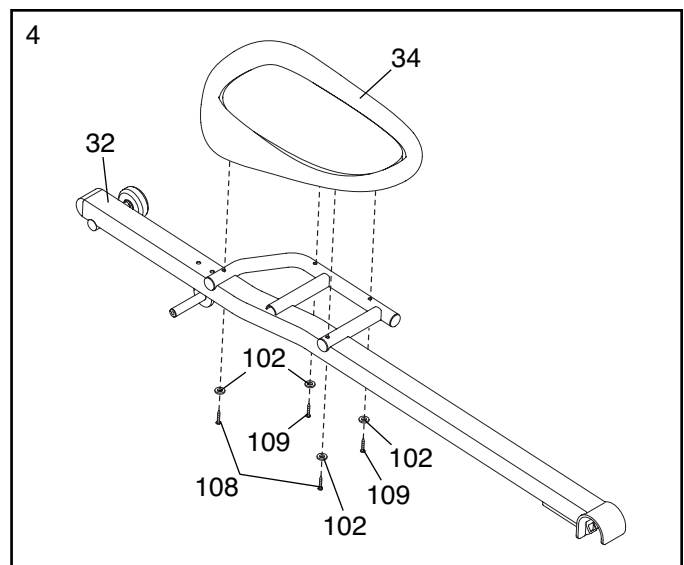

5. Insert the Roller (38) on the Left Pedal Arm (32) and the Roller on the Right Pedal Arm (33) into the sides of the Ramp (5).

Attach the Rear Ramp Cover (7) to the Ramp (5) with two M4 x 16mm Screws (97).

See the inset drawing. Lift the Pedal Arm Latch (41) on the Left Pedal Arm (32), and set the end of the Left Pedal Arm on the left Crank Bushing Sleeve (54). Release the Pedal Arm Latch, and make sure that the Left Pedal Arm is securely connected to the Crank Bushing Sleeve.

Connect the Right Pedal Arm (not shown) to the right Crank Bushing Sleeve (not shown) in the same way.

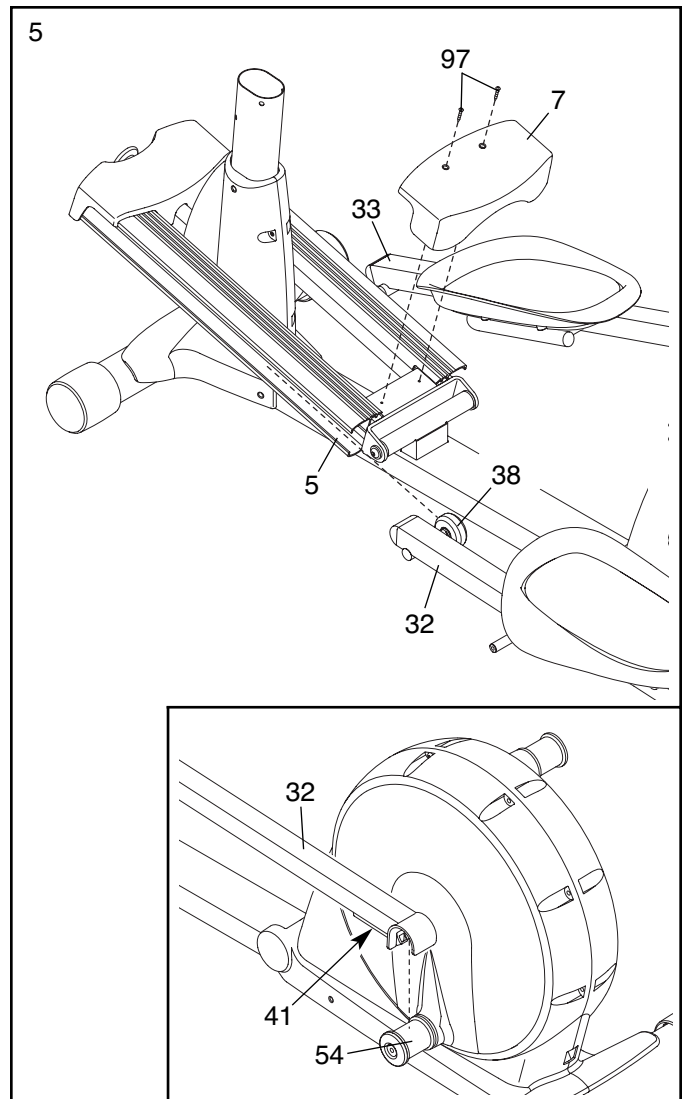

6. While another person holds the Upright (10) near the Frame (1), connect the ends of the Upper Wire Harness (65) to the ends of the Lower Wire Harness (64).

Carefully insert the Upright (10) into the Frame (1); **be careful not to damage the Wire Harnesses (64, 65)**. Attach the Upright with four M8 x 20mm Button Screws (107) and four M8 Split Washers (101).

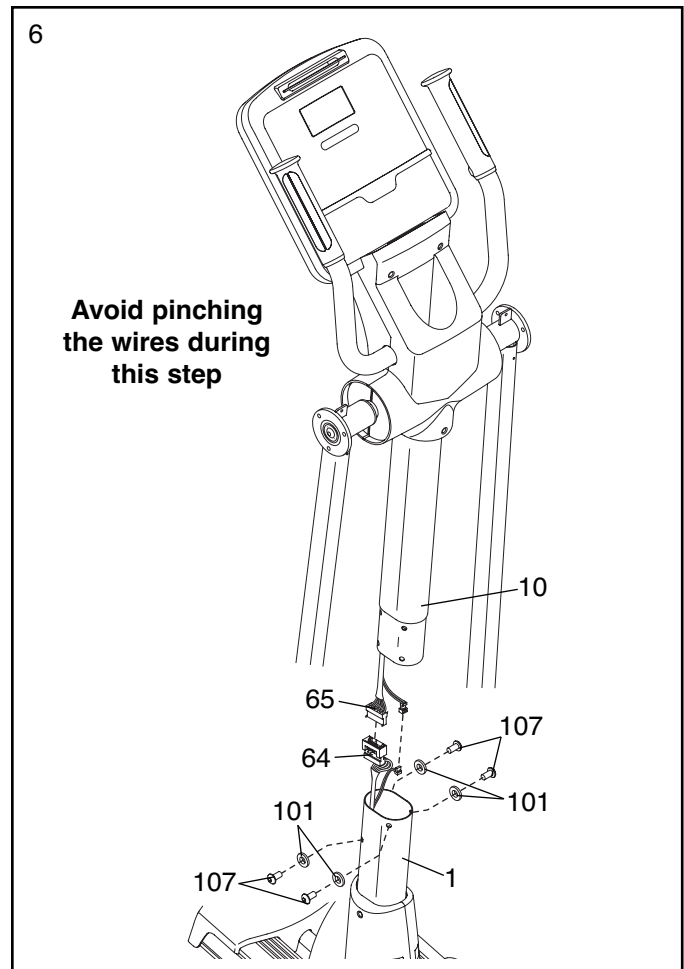

7. Attach the Left Upper Body Arm (22) to the left Upper Body Leg (24) with three M8 x 15mm Button Screws (106).

Attach the Right Upper Body Arm (23) in the same way.

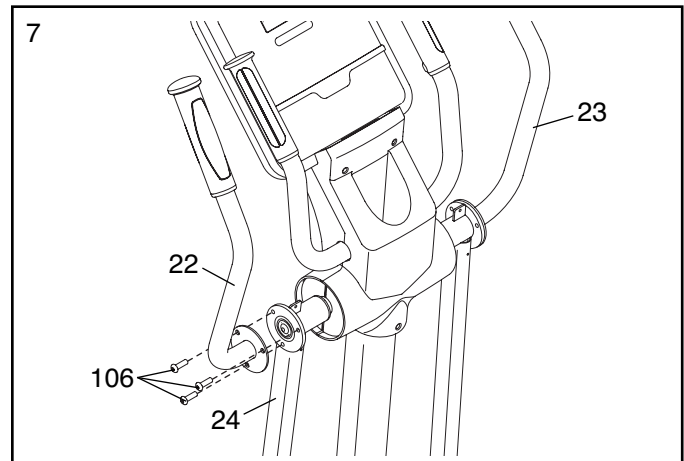

8. Hold the Left Rear Upper Body Cover (26) and the Left Front Upper Body Cover (27) around the left Upper Body Leg (24). Attach the Upper Body Covers with five M4 x 16mm Screws (97).

Attach the Right Rear Upper Body Cover (28) and the Right Front Upper Body Cover (29) in the same way.

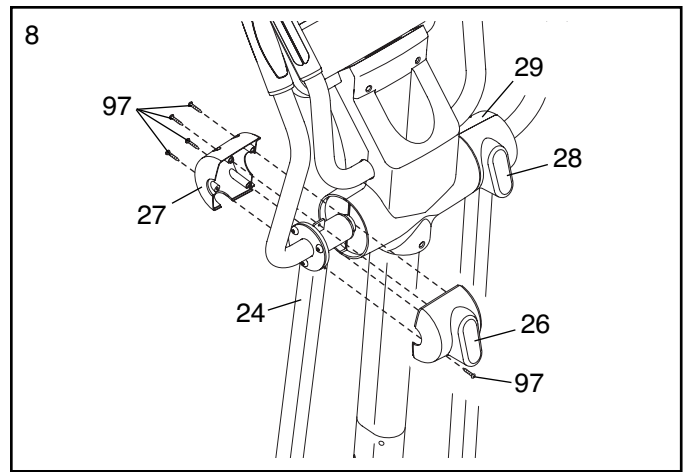

9. Apply a small amount of grease to the axle on the Left Link Arm (30), to the axle on the Left Pedal Arm (32), and to a Wave Washer (100).

Slide the Wave Washer (100) onto the axle on the Left Pedal Arm (32). Next, slide a Link Arm Spacer (74) onto the axle on the Left Link Arm (30).

Then, insert the axle on the Left Link Arm (30) into the left Upper Body Leg (24) while sliding the Left Link Arm onto the axle on the Left Pedal Arm (32).

Repeat this step with the Right Link Arm (31).

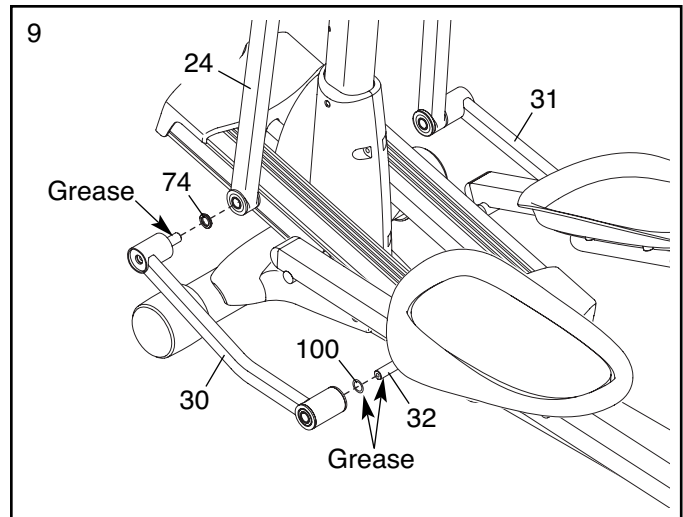

10. Attach the Left Link Arm (30) to the Left Pedal Arm (32) with an M8 x 15mm Button Screw (106), an M8.5 x 16mm x 1.5mm Washer (103), and an Axle Cover (66).

Attach the Left Link Arm (30) to the left Upper Body Leg (24) with an M8 x 25mm Button Screw (110), two M8.5 x 16mm x 1.5mm Washers (103), two Axle Covers (66), a Link Arm Spacer (74), and an M8 x 15mm Button Screw (106) as shown.

Attach the Right Link Arm (31) in the same way.

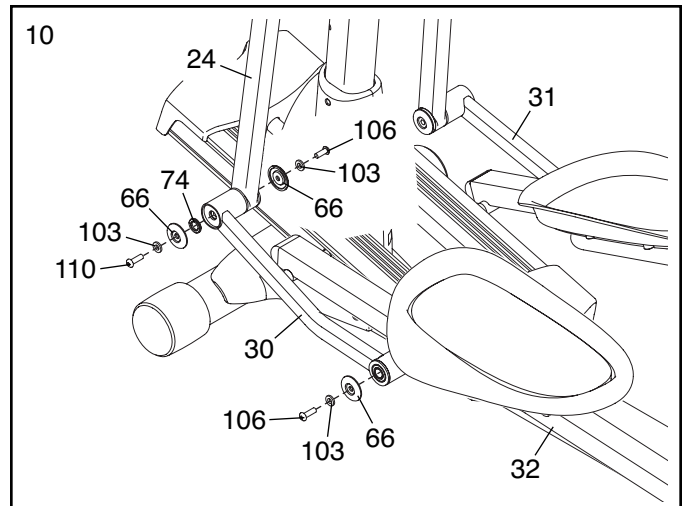

11. The Console (11) can be operated with four 1.5V "D" batteries (not included); alkaline batteries are recommended. Locate the two battery covers on the back of the Console. Press the tabs on the battery covers, and remove the battery covers. Next, insert two batteries into each battery compartment; **make sure that the batteries are oriented as shown by the symbols inside the battery compartments.** Then, reattach the battery covers.

The Console (11) can also be operated with a regulated 6-volt DC 2-amp power supply (not included). **To purchase a power supply, call the telephone number on the front cover of this manual. To avoid damaging the console, use only a manufacturer-supplied power supply.** Plug one end of the power supply into the jack on the elliptical exerciser; plug the other end into an outlet installed in accordance with all local codes and ordinances.

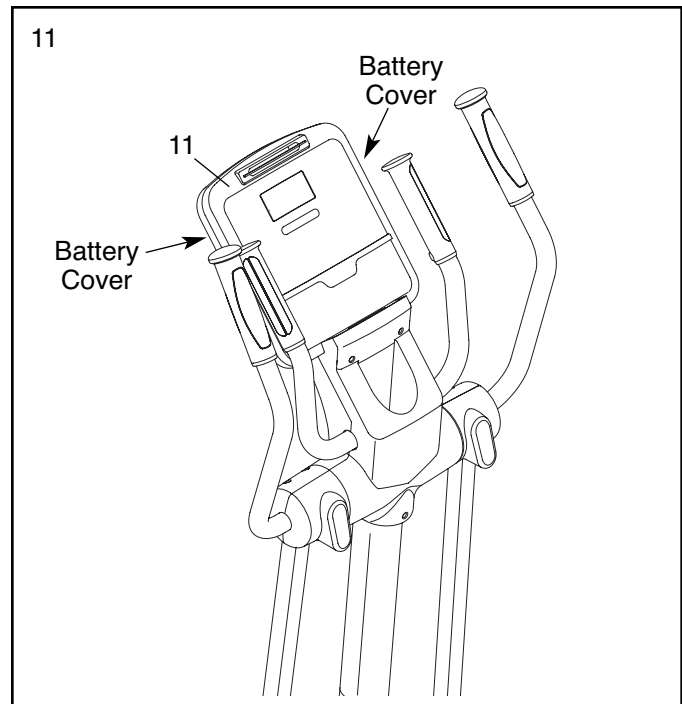

12. **Make sure that all parts of the elliptical exerciser are properly tightened.** Note: Some hardware may be left over after assembly is completed. To protect the floor or carpet from damage, place a mat under the elliptical exerciser.

HOW TO USE THE ELLIPTICAL EXERCISER

HOW TO FOLD AND UNFOLD THE ELLIPTICAL EXERCISER

When the elliptical exerciser is not in use, the frame can be folded out of the way. First, lift the latch under each pedal arm, and lift the pedal arms off the sleeves on the crank arms.

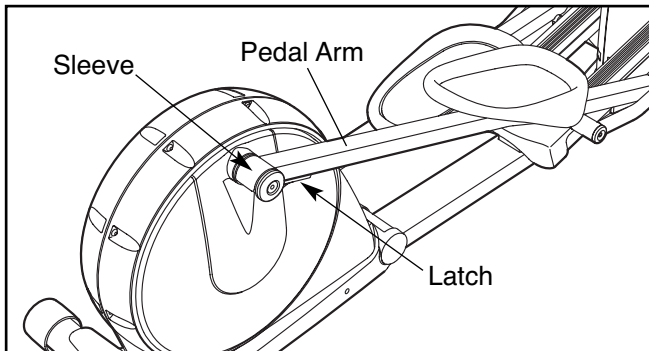

Next, raise the pedal arms until they touch the magnets on the upper body legs; the magnets will hold the pedal arms in place. Then, hold the handle and lift the frame until it locks in a vertical position.

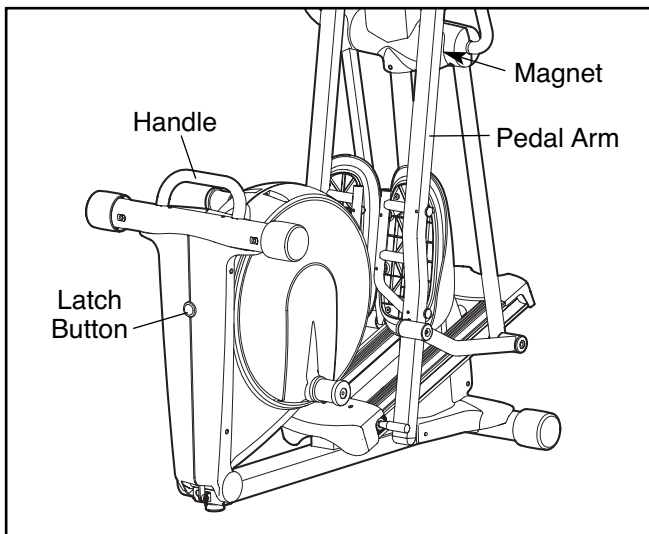

To use the elliptical exerciser, first hold the handle, press the latch button, and lower the frame.

Next, pull the pedal arms off the magnets on the upper body legs. Then, **lift the latches under the pedal arms**, and set the pedal arms on the sleeves on the crank arms. Release the latches, and make sure that the pedal arms are securely connected to the crank arms.

HOW TO MOVE THE ELLIPTICAL EXERCISER

To move the elliptical exerciser, first fold it as described at the left. Next, stand in front of the elliptical exerciser, hold the handgrip pulse sensors, and place one foot against the center of the front stabilizer. Pull the pulse sensors until the elliptical exerciser will roll on the front wheels. Carefully move the elliptical exerciser to the desired position, and then lower it.

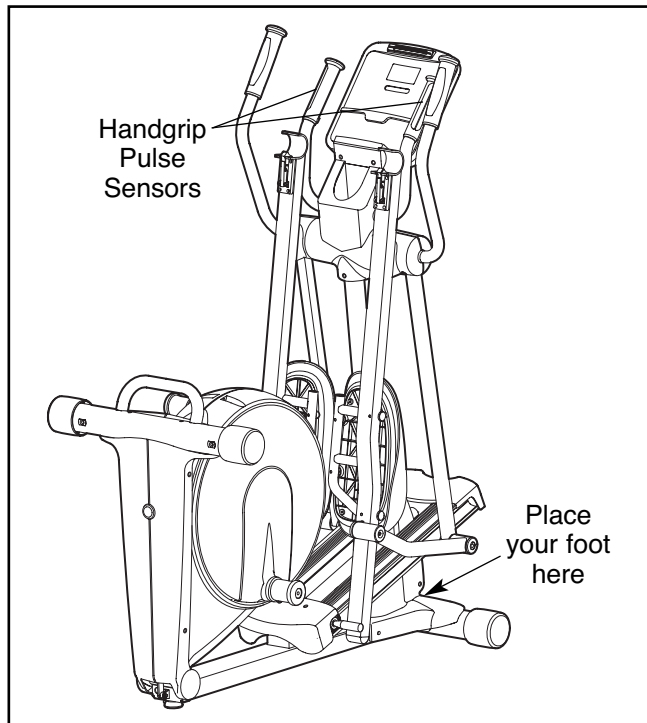

HOW TO CHANGE THE INCLINE OF THE RAMP

To vary the motion of the pedals, you can change the incline of the ramp. To change the incline, pull the ramp knob, raise or lower the ramp, and engage the ramp pin into one of the three adjustment holes in the front of the frame.

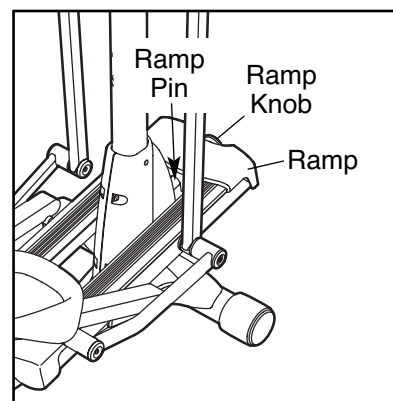

HOW TO EXERCISE ON THE ELLIPTICAL EXERCISER

To mount the elliptical exerciser, hold the upper body arms and step onto the pedal that is in the lower position. Next, step onto the other pedal. Push the pedals until they begin to move with a continuous motion.

Note: The crank arms can turn in either direction. It is recommended that you turn the crank arms in the direction shown by the arrow at the right; however, for variety you can turn the crank arms in the opposite direction.

To dismount the elliptical exerciser, wait until the pedals come to a complete stop. **Note: The elliptical exerciser does not have a free wheel; the pedals will continue to move until the flywheel stops.** When the pedals are stationary, step off the higher pedal first. Then, step off the lower pedal.

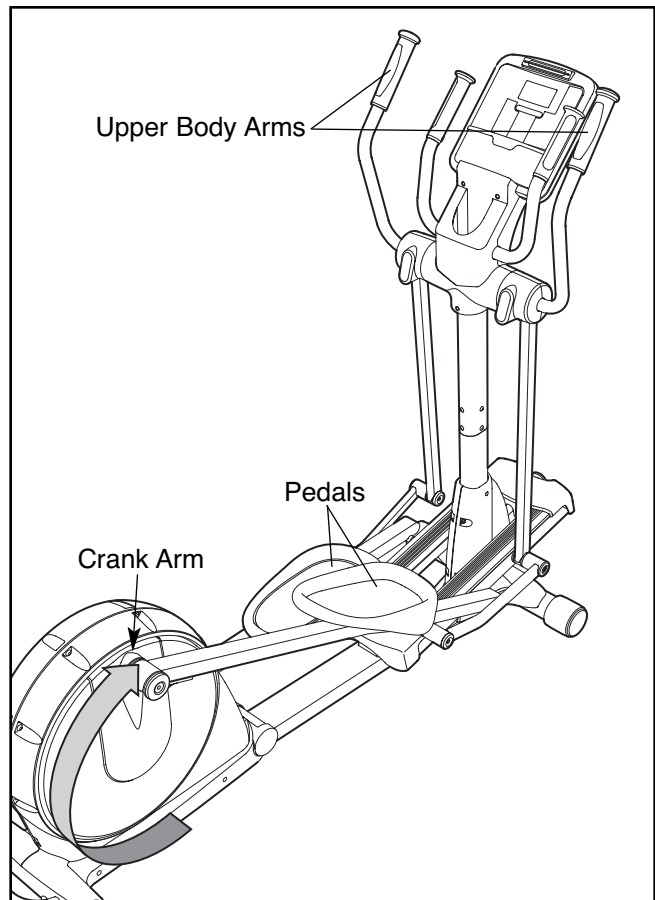

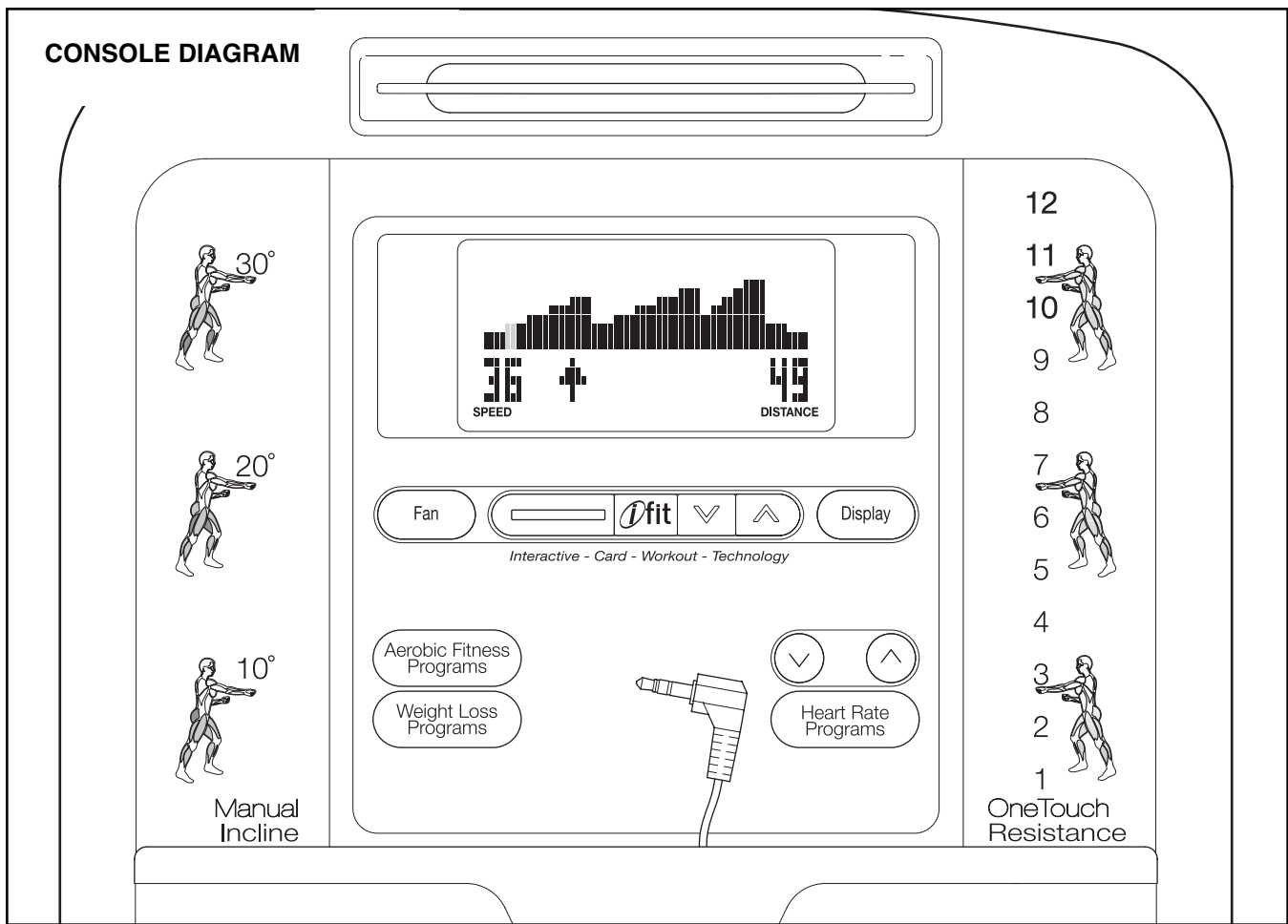

FEATURES OF THE CONSOLE

The advanced console offers an array of features designed to make your workouts more effective and enjoyable. When you select the manual mode of the console, you can change the resistance of the pedals with the touch of a button. As you exercise, the console will provide continuous exercise feedback. You can even measure your heart rate using the handgrip pulse sensor.

The console also offers six preset programs. Each program automatically changes the resistance of the pedals and prompts you to increase or decrease your pedaling speed as it guides you through an effective workout.

In addition, the console features two heart rate programs that change the resistance of the pedals to keep your heart rate near target heart rate settings while you exercise.

The console also features the new iFIT Interactive Workout System. The iFIT Interactive Workout System

is compatible with iFIT cards containing workout programs designed to help you achieve specific fitness goals. For example, lose unwanted pounds with the 8-week Weight Loss program. iFIT programs control the resistance of the pedals while the voice of a personal trainer coaches you and motivates you through your workouts. One iFIT card with three new programs is included. Additional iFIT cards are available separately. **To purchase iFIT cards, go to www.iFIT.com or call the telephone number on the front cover of this manual. iFIT cards are also available at select stores.**

You can even connect your MP3 player or CD player to the console's stereo sound system and listen to your favorite workout music or audio books while you exercise.

To use the manual mode of the console, follow the steps beginning on page 15. **To use a preset program,** see page 17. **To use a heart rate program,** see page 18. **To use an iFIT program,** see page 19. **To use the stereo sound system,** see page 19.

HOW TO USE THE MANUAL MODE

Note: If there is a sheet of clear plastic on the face of the console, remove the plastic.

1. Press any button on the console or begin pedaling to turn on the console.

When you turn on the console, the display will light. A tone will then sound and the console will be ready for use.

2. Select the manual mode.

When you turn on the console, the manual mode will be selected. If you have selected a program, reselect the manual mode by pressing any of the Programs buttons repeatedly until zeros appear in the display.



3. Begin pedaling and change the resistance of the pedals as desired.

As you pedal, change the resistance of the pedals by pressing the OneTouch Resistance buttons. There are twelve resistance levels. Note: After you press the buttons, it will take a moment for the pedals to reach the selected resistance level.

4. Follow your progress with the display.

While you pedal, the upper left corner of the display will show the elapsed time.

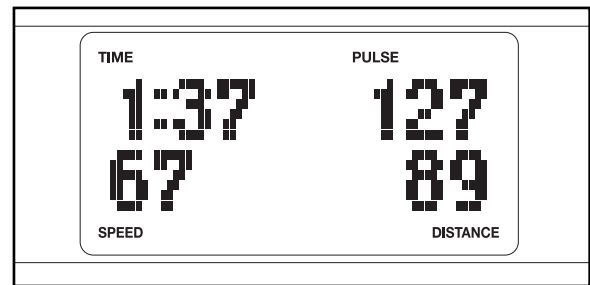

The lower left corner of the display will show your pedaling speed, in revolutions per minute.

The upper right corner of the display will show your heart rate when you use the handgrip pulse sensor (see step 5 on page 16).

The lower right corner of the display will show the distance (total number of revolutions) that you have pedaled.

The center of the display will show the resistance setting of the pedals for a few seconds each time the resistance setting changes.

To view the approximate number of calories that you are burning per hour and the approximate number of calories that you have burned during your workout, press the Display button.

You can also view selected information at a larger size. Press the Display button repeatedly to view the elapsed time, the distance that you have pedaled, your pedaling speed, or the approximate number of calories that you have burned.

To again view the elapsed time, your pedaling speed, and the distance that you have pedaled, press the Display button again.

5. Measure your heart rate if desired.

If there are sheets of clear plastic on the metal contacts on the handgrip pulse sensor, remove the plastic. In addition, make sure that your hands are clean. To measure your heart rate, hold the handgrip pulse sensor with your palms resting against the metal contacts. Avoid moving your hands or gripping the contacts tightly.

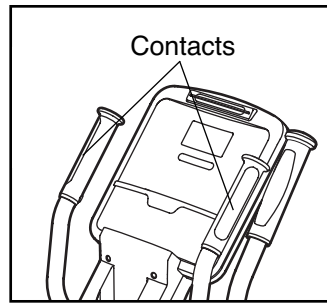

When your pulse is detected, your heart rate will be shown in the display. For the most accurate heart rate reading, hold the contacts for at least 15 seconds.

If your heart rate is not shown, make sure that your hands are positioned as described. Be careful not to move your hands excessively or to squeeze the metal contacts tightly. For optimal performance, clean the metal contacts using a soft cloth; **never use alcohol, abrasives, or chemicals to clean the contacts.**

6. Turn on the fan if desired.

To turn on the fan at high speed, press the Fan button. To turn on the fan at low speed, press the Fan button a second time. To select the auto mode, press the Fan button a third time; while the auto mode is selected, the speed of the fan will automatically increase or decrease as you increase or decrease your pedaling speed.

Pivot the fan louvers above the display upward or downward to direct the airflow from the fan.

To turn off the fan, press the Fan button again. Note: If the pedals do not move for about thirty seconds, the fan will automatically turn off to conserve the batteries.

7. When you are finished exercising, the console will turn off automatically.

If the pedals do not move for several seconds, a series of tones will sound and the console will pause.

If the pedals do not move for about five minutes, the console will turn off and the displays will be reset.

HOW TO USE A PRESET PROGRAM

1. **Press any button on the console or begin pedaling to turn on the console.**

See step 1 on page 15.

2. **Select a preset program.**

To select one of the three weight loss programs, press the Weight Loss Programs button repeatedly; to select one of the three aerobic fitness programs, press the Aerobic Fitness Programs button repeatedly.

When you select a preset program, the name of the program will appear in the display for a few seconds. A profile of the resistance settings of the program will then appear in the display.

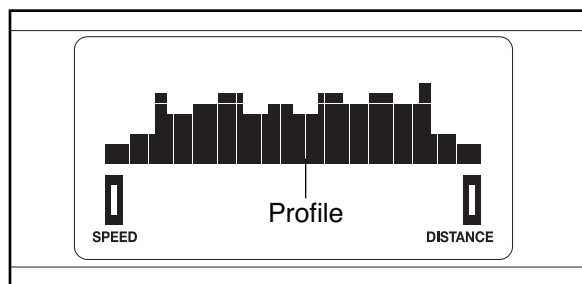

3. **Begin pedaling to start the program.**

Each program is divided into either 20 or 30 one-minute segments. One resistance setting and one target speed setting are programmed for each segment. Note: The same resistance setting and/or target speed setting may be programmed for consecutive segments.

During the program, the program profile will show your progress (see the drawing above). The flashing column of the profile represents the current segment of the program. The height of the flashing column indicates the resistance setting for the current segment. At the end of each segment of the program, a series of tones will sound and the next segment of the profile will begin to flash. If a different resistance setting is programmed for the next segment, the resistance setting will appear in the display for a few seconds to alert you. The resistance of the pedals will then change.

As you exercise, you will be prompted to keep your pedaling speed near the target speed setting for the current segment. When

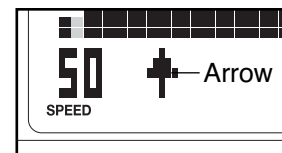

an upward-pointing arrow appears in the display, increase your speed. When a downward-pointing arrow appears, decrease your speed. When no arrow appears, maintain your current speed.

IMPORTANT: The target speed settings are intended only to provide motivation. Make sure to pedal at a speed that is comfortable for you.

If the resistance setting for the current segment is too high or too low, you can manually override the setting by pressing the OneTouch Resistance buttons. However, when the current segment ends, the resistance of the pedals will automatically adjust to the resistance setting for the next segment.

If you stop pedaling for several seconds, a series of tones will sound and the program will pause. To restart the program, simply resume pedaling. The program will continue until the last segment of the profile ends.

4. **Follow your progress with the display.**

During the program, the display will show the program profile, your pedaling speed, and the distance that you have pedaled.

To view the time remaining in the program instead of the program profile, press the Display button.

To view the approximate number of calories that you are burning per hour and the approximate number of calories that you have burned during your workout, press the Display button again.

To view the program profile again, press the Display button again.

5. **Measure your heart rate if desired.**

See step 5 on page 16.

6. **Turn on the fan if desired.**

See step 6 on page 16.

7. **When you are finished exercising, the console will turn off automatically.**

See step 7 on page 16.

HOW TO USE A HEART RATE PROGRAM

1. **Press any button on the console or begin pedaling to turn on the console.**

See step 1 on page 15.

2. **Select a heart rate program.**

To select one of the heart rate programs, press the Heart Rate Programs button repeatedly until the words HEART RATE 1 or HEART RATE 2 appear in the display.

3. **Enter a target heart rate setting.**

A few seconds after you select a heart rate program, the words ENTER HEART RATE will appear in the display and the number 110 will begin to flash.

During heart rate program 1, the same target heart rate setting will be programmed for all segments of the program. If you have selected heart rate program 1, press the increase and decrease buttons above the Heart Rate Programs button to enter the desired target heart rate setting (see EXERCISE INTENSITY on page 21).

During heart rate program 2, different target heart rate settings will be programmed for different segments of the program. If you have selected heart rate program 2, press the increase and decrease buttons above the Heart Rate Programs button to enter the desired maximum target heart rate setting for the program (see EXERCISE INTENSITY on page 21).

4. **Hold the handgrip pulse sensor.**

It is not necessary to hold the handgrip pulse sensor continuously during heart rate programs; however, you should hold the handgrip pulse sensor frequently for the programs to operate properly.

Each time you hold the handgrip pulse sensor, keep your hands on the metal contacts for at least 30 seconds.

5. **Begin pedaling to start the program.**

Heart rate program 1 is divided into 40 one-minute segments. Note: For a shorter workout, stop exercising or select a different program before the program ends.

Heart rate program 2 is divided into 30 one-minute segments. One target heart rate setting is programmed for each segment. Note: The same target heart rate setting may be programmed for consecutive segments.

During the program, the program profile in the display will show your progress. The flashing column of the profile represents the current segment of the program. The height of the flashing column indicates the target heart rate setting for the current segment. At the end of each segment of the program, a series of tones will sound and the next segment of the profile will begin to flash.

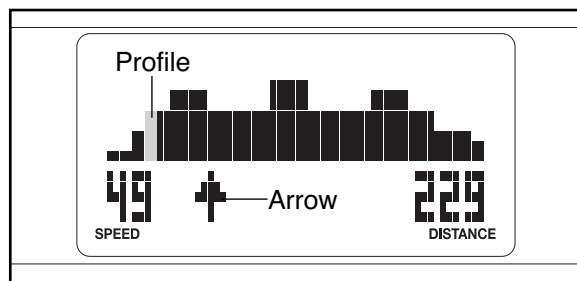

During both programs, the console will regularly compare your heart rate to the target heart rate setting for the current segment of the program. If your heart rate is too far below or above the target heart rate setting, the resistance of the pedals will automatically increase or decrease to bring your heart rate closer to the target heart rate setting. Each time the resistance changes, the resistance setting will appear in the display for a few seconds to alert you.

While you exercise, you will be prompted to maintain a constant pedaling speed. If an upward-pointing arrow appears in the display (see the drawing above), increase your speed. If a downward-pointing arrow appears, decrease your speed. When no arrow appears, maintain your current speed.

If the resistance setting for the current segment is too high or too low, you can manually override the setting by pressing the OneTouch Resistance buttons. However, when the console compares your heart rate to the target heart rate setting, the resistance of the pedals may automatically increase or decrease to bring your heart rate closer to the target heart rate setting.

If you stop pedaling for several seconds, a series of tones will sound and the program will pause. To restart the program, simply resume pedaling. The program will continue until the last segment of the program ends.

6. Follow your progress with the display.

During heart rate program 1, the display will show your heart rate, your pedaling speed, and the distance that you have pedaled. **During heart rate program 2**, the display will show the program profile, your pedaling speed, and the distance that you have pedaled.

To view the time remaining in the program instead of your heart rate or the program profile, press the Display button.

To view the approximate number of calories that you are burning per hour and the approximate number of calories that you have burned during your workout, press the Display button again.

To view your heart rate or the program profile again, press the Display button again.

7. Turn on the fan if desired.

See step 6 on page 16.

8. When you are finished exercising, the console will turn off automatically.

See step 7 on page 16.

HOW TO USE AN IFIT PROGRAM

1. Press any button on the console or begin pedaling to turn on the console.

See step 1 on page 15.

2. Insert an iFIT card and select a program.

To use an iFIT program, insert an iFIT card into the iFIT slot; make sure that the iFIT card is oriented so the metal contacts are face down and are facing the slot. When the iFIT card is properly inserted, the indicator next to the slot will light and the words IFIT 1 will appear in the display.

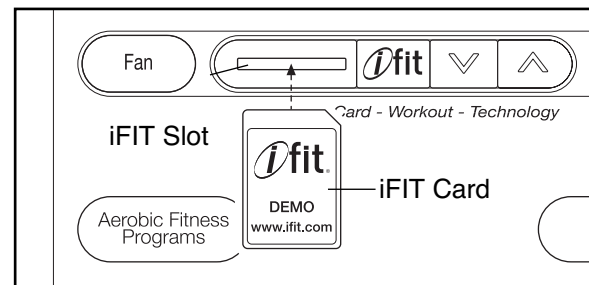

Next, select the desired program on the iFIT card by pressing the up and down buttons next to the iFIT slot.

A moment after you select a program, the voice of a personal trainer will begin guiding you through your workout. iFIT programs work in the same way as preset programs. To use the program, see steps 3 to 6 on page 17.

HOW TO USE THE STEREO SOUND SYSTEM

To play music or audio books through the console's stereo sound system while you exercise, first locate the stereo audio cable in the center of the console above the speakers. Plug the cable into a jack on your MP3 player or CD player; **make sure that the audio cable is fully plugged in.**

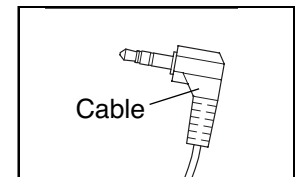

Next, press the play button on your MP3 player or CD player. Adjust the volume of the speakers using the volume control on your MP3 player or CD player.

When not in use, insert the stereo audio cable into the storage bracket on the console.

MAINTENANCE AND TROUBLESHOOTING

Inspect and tighten all parts of the elliptical exerciser regularly. Replace any worn parts immediately.

To clean the elliptical exerciser, use a damp cloth and a small amount of mild soap. **IMPORTANT: To avoid damage to the console, keep liquids away from the console and keep the console out of direct sunlight.**

BATTERY REPLACEMENT

If the console display becomes dim, the batteries should be replaced; most console problems are the result of low batteries. See assembly step 11 on page 11 for replacement instructions.

HOW TO LEVEL THE ELLIPTICAL EXERCISER OR ELIMINATE FLEXING IN THE FRAME

If the elliptical exerciser rocks on your floor during use, turn one or both of the Leveling Feet (98) until the rocking motion is eliminated.

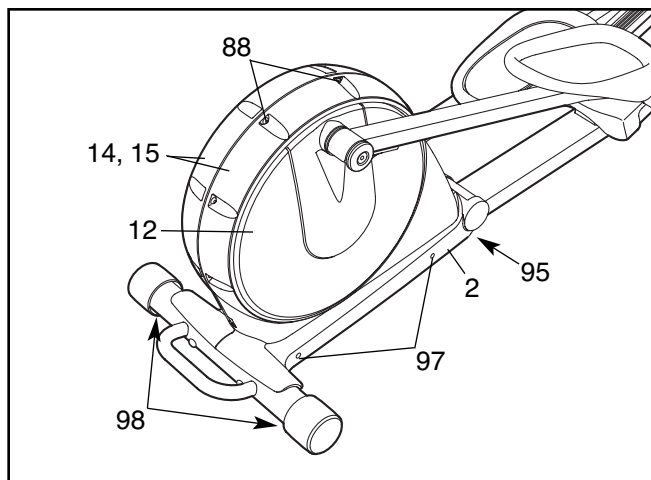

If the elliptical exerciser flexes in the center during use, turn the Center Foot (95) until the flexing is eliminated.

HOW TO ELIMINATE RUBBING OF THE DISCS

See the drawing above. If the Discs (12) rub against the Side Shields (14, 15) during use, make sure that the Center Foot (95) is installed in the Folding Frame (2). If the Center Foot is installed, loosen the two indicated Bolt Sets (88) and the two M4 x 16mm Screws (97) in each side of the elliptical exerciser.

Adjust the position of the Side Shields (14, 15) until the Discs (12) no longer rub against them, and then tighten the Bolt Sets (88) and the M4 x 16mm Screws (97).

HANDGRIP PULSE SENSOR TROUBLESHOOTING

If the handgrip pulse sensor does not function properly, see step 5 on page 16.

HOW TO ADJUST THE BELT

If the pedals slip while you are pedaling, even while the resistance is adjusted to the highest setting, the belt may need to be adjusted. To adjust the belt, first carefully pry off the left Disc Cover (13)

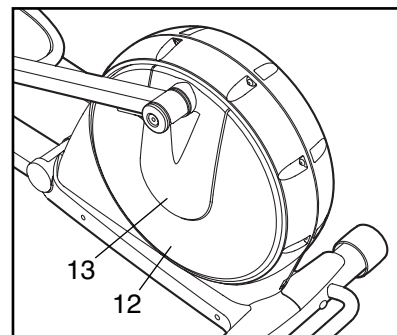

using a flat screwdriver. Next, remove the four Screws (not shown) from the center of the left Disc (12). Gently rotate the Disc Cover and the Disc away from the elliptical exerciser.

Loosen, but do not remove, the three 1/4" x 19mm Button Screws (114). Insert the shaft of a screwdriver downward between the Idler (47) and the Idler Pulley (48). Pull the top of the screwdriver toward the rear of the elliptical exerciser until the Belt (96) is tight, and then tighten the three Button Screws.

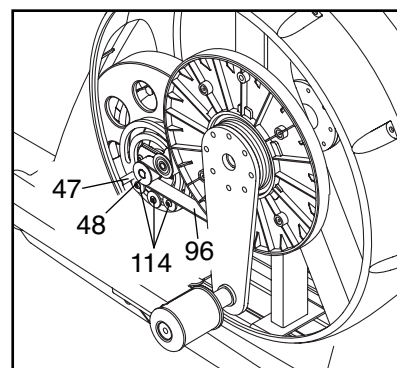

Reattach the left disc with the four screws and then reattach the left disc cover.

EXERCISE GUIDELINES

⚠ WARNING: Before beginning this or any exercise program, consult your physician. This is especially important for persons over the age of 35 or persons with pre-existing health problems.

The pulse sensor is not a medical device. Various factors may affect the accuracy of heart rate readings. The pulse sensor is intended only as an exercise aid in determining heart rate trends in general.

These guidelines will help you to plan your exercise program. For detailed exercise information, obtain a reputable book or consult your physician. Remember, proper nutrition and adequate rest are essential for successful results.

EXERCISE INTENSITY

Whether your goal is to burn fat or to strengthen your cardiovascular system, exercising at the proper intensity is the key to achieving results. You can use your heart rate as a guide to find the proper intensity level. The chart below shows recommended heart rates for fat burning and aerobic exercise.

165	155	145	140	130	125	115	♥
145	138	130	125	118	110	103	♥
125	120	115	110	105	95	90	♥
<hr/>							
20	30	40	50	60	70	80	

To find the proper intensity level, find your age at the bottom of the chart (ages are rounded off to the nearest ten years). The three numbers listed above your age define your “training zone.” The lowest number is the heart rate for fat burning, the middle number is the heart rate for maximum fat burning, and the highest number is the heart rate for aerobic exercise.

Burning Fat—To burn fat effectively, you must exercise at a low intensity level for a sustained period of time. During the first few minutes of exercise, your body uses *carbohydrate calories* for energy. Only after the first few minutes of exercise does your body begin to use stored *fat calories* for energy. If your goal is to burn fat, adjust the intensity of your exercise until your heart rate is near the lowest number in your training zone. For maximum fat burning, exercise with your heart rate near the middle number in your training zone.

Aerobic Exercise—If your goal is to strengthen your cardiovascular system, you must perform aerobic exercise, which is activity that requires large amounts of oxygen for prolonged periods of time. For aerobic exercise, adjust the intensity of your exercise until your heart rate is near the highest number in your training zone.

WORKOUT GUIDELINES

Warming up—Start with 5 to 10 minutes of stretching and light exercise. A warm-up increases your body temperature, heart rate, and circulation in preparation for exercise.

Training Zone Exercise—Exercise for 20 to 30 minutes with your heart rate in your training zone. (During the first few weeks of your exercise program, do not keep your heart rate in your training zone for longer than 20 minutes.) Breathe regularly and deeply as you exercise—never hold your breath.

Cooling down—Finish with 5 to 10 minutes of stretching. Stretching increases the flexibility of your muscles and helps to prevent post-exercise problems.

EXERCISE FREQUENCY

To maintain or improve your condition, complete three workouts each week, with at least one day of rest between workouts. After a few months of regular exercise, you may complete up to five workouts each week, if desired. Remember, the key to success is to make exercise a regular and enjoyable part of your everyday life.

SUGGESTED STRETCHES

The correct form for several basic stretches is shown at the right. Move slowly as you stretch—never bounce.

1. Toe Touch Stretch

Stand with your knees bent slightly and slowly bend forward from your hips. Allow your back and shoulders to relax as you reach down toward your toes as far as possible. Hold for 15 counts, then relax. Repeat 3 times. Stretches: Hamstrings, back of knees and back.

2. Hamstring Stretch

Sit with one leg extended. Bring the sole of the opposite foot toward you and rest it against the inner thigh of your extended leg. Reach toward your toes as far as possible. Hold for 15 counts, then relax. Repeat 3 times for each leg. Stretches: Hamstrings, lower back and groin.

3. Calf/Achilles Stretch

With one leg in front of the other, reach forward and place your hands against a wall. Keep your back leg straight and your back foot flat on the floor. Bend your front leg, lean forward and move your hips toward the wall. Hold for 15 counts, then relax. Repeat 3 times for each leg. To cause further stretching of the achilles tendons, bend your back leg as well. Stretches: Calves, achilles tendons and ankles.

4. Quadriceps Stretch

With one hand against a wall for balance, reach back and grasp one foot with your other hand. Bring your heel as close to your buttocks as possible. Hold for 15 counts, then relax. Repeat 3 times for each leg. Stretches: Quadriceps and hip muscles.

5. Inner Thigh Stretch

Sit with the soles of your feet together and your knees outward. Pull your feet toward your groin area as far as possible. Hold for 15 counts, then relax. Repeat 3 times. Stretches: Quadriceps and hip muscles.

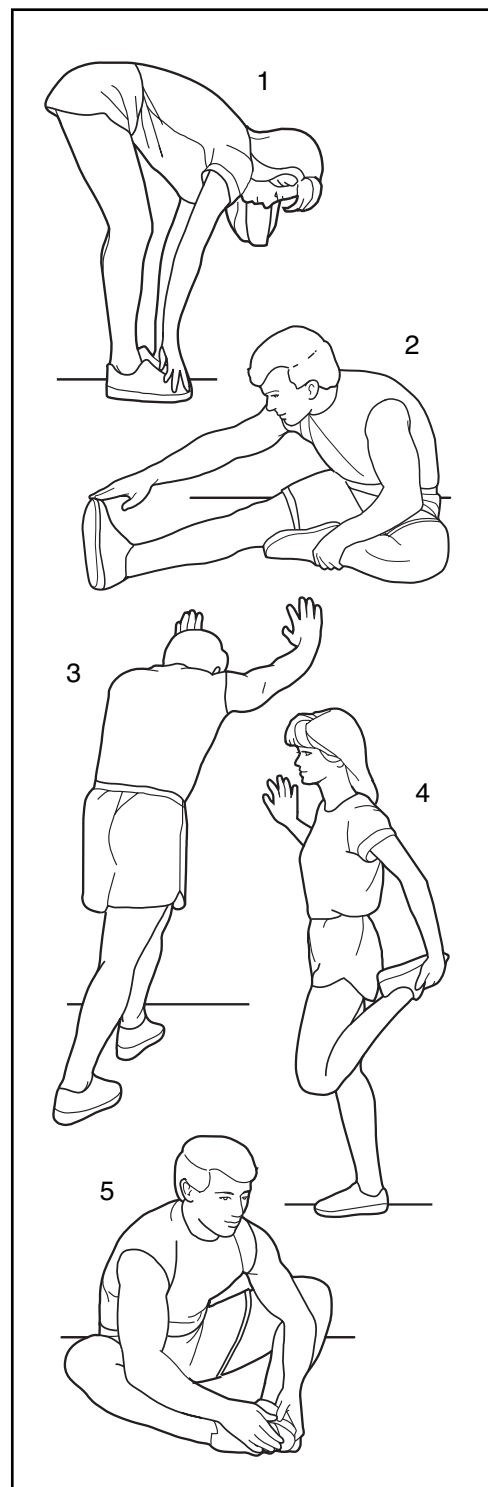

NOTES

PART LIST—Model No. PFEL77908.2

R0308A

Key No.	Qty.	Description	Key No.	Qty.	Description
1	1	Frame	51	1	Clamp
2	1	Folding Frame	52	2	Large Axle Cover
3	1	Rear Stabilizer	53	2	Crank Bushing
4	1	Front Stabilizer	54	2	Crank Bushing Sleeve
5	1	Ramp	55	2	Crank Arm
6	1	Front Ramp Cover	56	1	Crank Arm Spacer
7	1	Rear Ramp Cover	57	1	Large Pulley
8	2	Side Ramp Cover	58	1	Crank Flange
9	1	Ramp Knob	59	1	Left Crank Bearing Assembly
10	1	Upright	60	1	Crank Spacer
11	1	Console	61	1	Crank
12	2	Disc	62	1	Ramp Pin
13	2	Disc Cover	63	1	Ramp Spring
14	1	Left Side Shield	64	1	Lower Wire Harness
15	1	Right Side Shield	65	1	Upper Wire Harness
16	2	Rear Endcap	66	6	Axle Cover
17	2	Wheel	67	8	Bushing Assembly
18	2	Wheel Cover	68	4	Brass Bushing
19	1	Rear Upright Cover	69	1	Latch Bracket
20	1	Front Upright Cover	70	1	Latch Spring
21	2	Handgrip	71	1	Upper Body Axle
22	1	Left Upper Body Arm	72	1	Ramp Axle
23	1	Right Upper Body Arm	73	1	Pivot Axle
24	2	Upper Body Leg	74	4	Link Arm Spacer
25	2	Pulse Sensor/Wire	75	1	Latch Axle
26	1	Left Rear Upper Body Cover	76	1	Latch Button
27	1	Left Front Upper Body Cover	77	1	Latch Frame
28	1	Right Rear Upper Body Cover	78	2	Upright Brass Bushing
29	1	Right Front Upper Body Cover	79	4	Bearing Assembly
30	1	Left Link Arm	80	4	M6 Nylon Locknut
31	1	Right Link Arm	81	6	M4 x 16mm Cupped Screw
32	1	Left Pedal Arm	82	4	M10 x 93mm Button Screw
33	1	Right Pedal Arm	83	2	Crank Snap Ring
34	1	Left Pedal	84	2	Crank Arm Washer
35	1	Right Pedal	85	2	Outside Crank Bushing
36	1	Left Frame Cover	86	1	Flange Screw
37	1	Right Frame Cover	87	4	M10 x 25mm Washer
38	2	Roller	88	7	Bolt Set
39	2	Pedal Arm Endcap	89	2	Small Snap Ring
40	1	Tray	90	1	Idler Snap Ring
41	2	Pedal Arm Latch	91	1	Eddy Snap Ring
42	4	Pedal Arm Latch Spring	92	1	Idler Spacer
43	6	Pedal Arm Cap	93	2	M10 Nylon Locknut
44	1	Eddy Mechanism	94	3	Idler Washer
45	1	Eddy Crank Assembly	95	1	Center Foot
46	1	Pillow Block	96	1	Belt
47	1	Idler	97	51	M4 x 16mm Screw
48	1	Idler Pulley	98	2	Leveling Foot
49	1	Eddy Motor	99	4	M10 Curved Washer
50	1	Reed Switch/Wire	100	4	Wave Washer

Key No.	Qty.	Description	Key No.	Qty.	Description
101	4	M8 Split Washer	111	4	M10 x 20mm Button Screw
102	12	M6 Split Washer	112	8	M8 x 25mm Shoulder Screw
103	8	M8.5 x 16mm x 1.5mm Washer	113	2	M8 x 30mm Button Screw
104	4	M8 x 20mm x 2mm Washer	114	5	1/4" x 19mm Button Screw
105	4	M8 x 16mm Button Screw	115	3	M4 x 12mm Screw
106	10	M8 x 15mm Button Screw	116	1	Right Crank Bearing Assembly
107	4	M8 x 20mm Button Screw	*	–	User's Manual
108	4	M6 x 62mm Screw	*	–	Hex Key
109	4	M6 x 35mm Screw	*	–	Grease Packet
110	6	M8 x 25mm Button Screw	*	–	Power Supply Wire

Note: Specifications are subject to change without notice. See the back cover of this manual for information about ordering replacement parts. *These parts are not illustrated.

EXPLODED DRAWING A—Model No. PFEL77908.2

R0308A

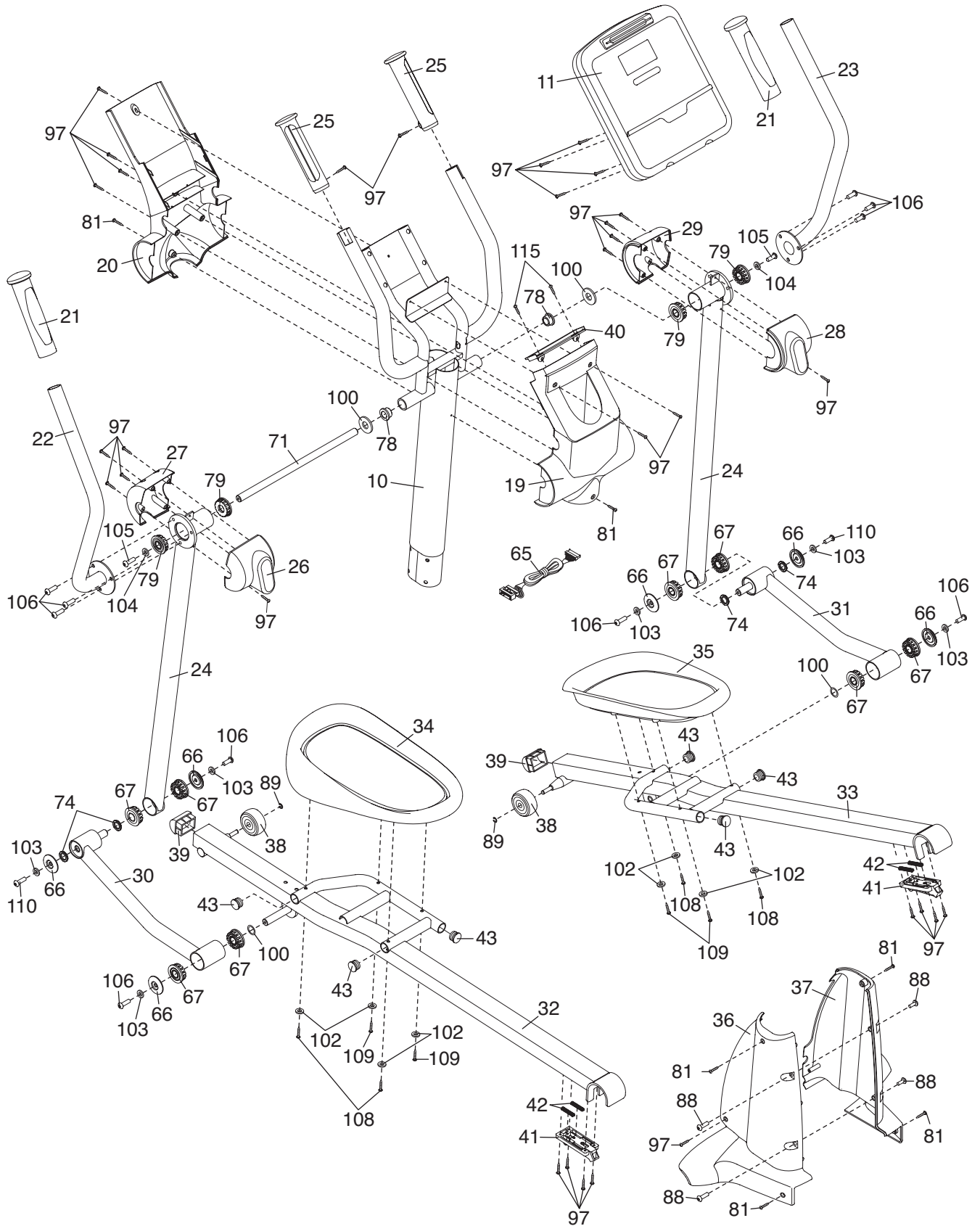

EXPLODED DRAWING B—Model No. PFEL77908.2

R0308A

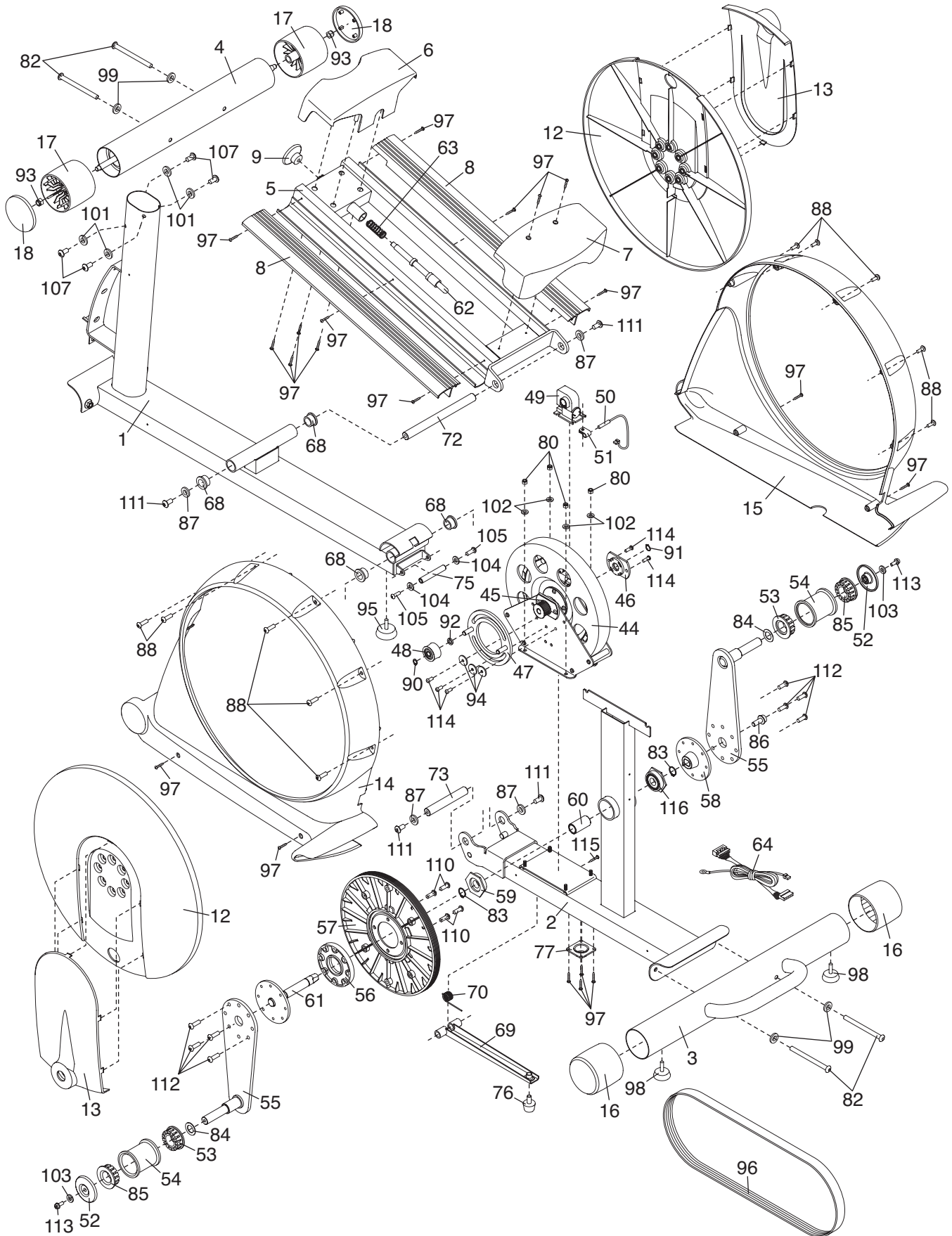

ORDERING REPLACEMENT PARTS

To order replacement parts, please see the front cover of this manual. To help us assist you, be prepared to provide the following information when contacting us:

- the model number and serial number of the product (see the front cover of this manual)
- the name of the product (see the front cover of this manual)
- the key number and description of the replacement part(s) (see the PART LIST and the EXPLODED DRAWING near the end of this manual)

LIMITED WARRANTY

ICON Health & Fitness, Inc. (ICON) warrants this product to be free from defects in workmanship and material, under normal use and service conditions, for a period of one (1) year from the date of purchase. There is a lifetime warranty on the frame. This warranty extends only to the original purchaser. ICON's obligation under this warranty is limited to replacing or repairing, at ICON's option, the product through one of its authorized service centers. All repairs for which warranty claims are made must be pre-authorized by ICON. If the product is shipped to a service center, freight charges to and from the service center will be the customer's responsibility. For in-home service, the customer will be responsible for a minimal trip charge. This warranty does not extend to any product or damage to a product caused by or attributable to freight damage, abuse, misuse, improper or abnormal usage or repairs not provided by an ICON authorized service center; products used for commercial or rental purposes; or products used as store display models. No other warranty beyond that specifically set forth above is authorized by ICON.

ICON is not responsible or liable for indirect, special or consequential damages arising out of or in connection with the use or performance of the product or damages with respect to any economic loss, loss of property, loss of revenues or profits, loss of enjoyment or use, costs of removal or installation or other consequential damages of whatsoever nature. Some states do not allow the exclusion or limitation of incidental or consequential damages. Accordingly, the above limitation may not apply to you.

The warranty extended hereunder is in lieu of any and all other warranties and any implied warranties of merchantability or fitness for a particular purpose is limited in its scope and duration to the terms set forth herein. Some states do not allow limitations on how long an implied warranty lasts. Accordingly, the above limitation may not apply to you.

This warranty gives you specific legal rights. You may also have other rights which vary from state to state.

ICON HEALTH & FITNESS, INC., 1500 S. 1000 W., LOGAN, UT 84321-9813