

NordicTrack[®] *TRL 625*

Patent Pending

Model No. 831.298960

Serial No. _____

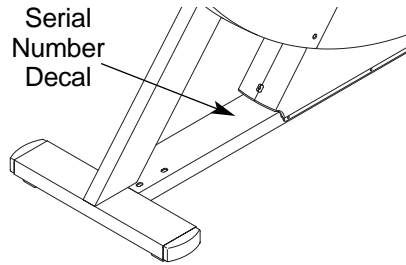

USER'S MANUAL

QUESTIONS?

As a manufacturer, we are committed to providing complete customer satisfaction. If you have questions, or if there are missing parts, we will guarantee complete satisfaction through direct assistance from our factory.

TO AVOID UNNECESSARY DELAYS, PLEASE CALL DIRECT TO OUR TOLL-FREE CUSTOMER HOT LINE. The trained technicians on our customer hot line will provide immediate assistance, free of charge to you.

CUSTOMER HOT LINE:

1-888-825-2588

Mon.-Fri., 6 a.m.-6 p.m. MST

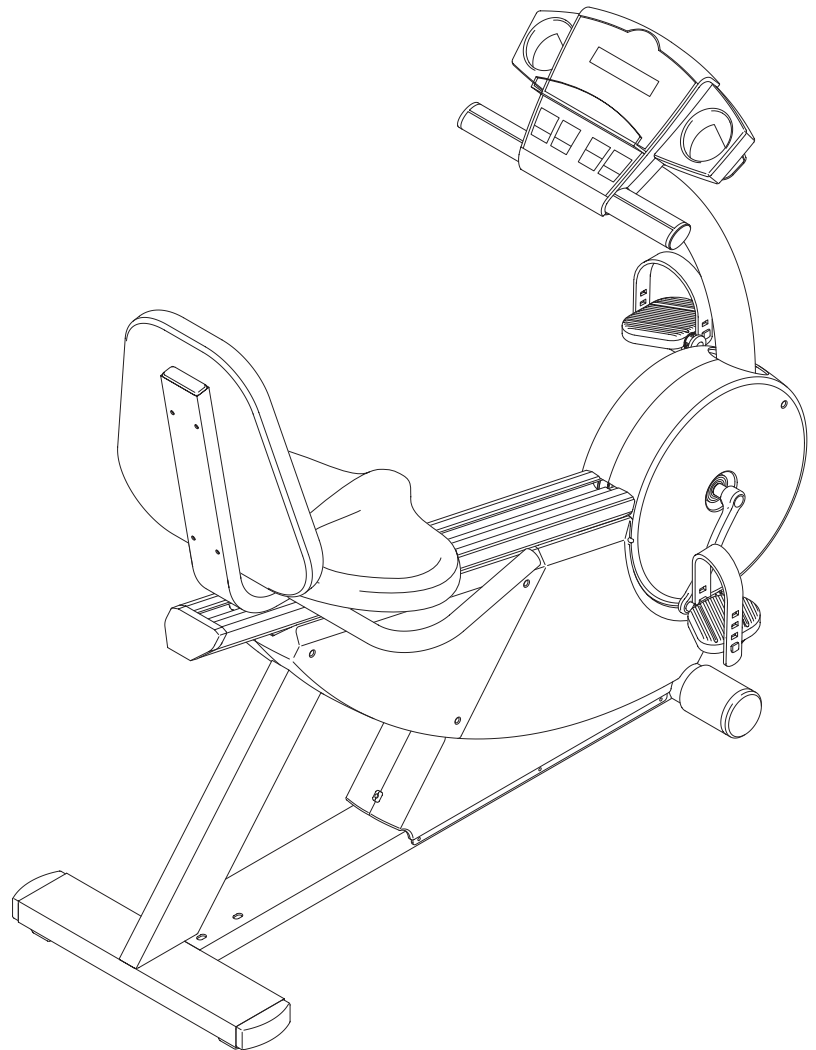

CAUTION

Read all precautions and instructions in this manual before using this equipment. Keep this manual for future reference.



Visit our website at

www.nordictrack.com

*new products, prizes,
fitness tips, and much more!*

NordicTrack[®] *TRL 625*

TABLE OF CONTENTS

IMPORTANT PRECAUTIONS	3
BEFORE YOU BEGIN	4
ASSEMBLY	5
HOW TO OPERATE THE RECUMBENT CYCLE	9
MAINTENANCE AND TROUBLE-SHOOTING	12
EXERCISE GUIDELINES	13
PART LIST	14
EXPLODED DRAWING	15
HOW TO ORDER REPLACEMENT PARTSBack Cover
LIMITED WARRANTYBack Cover

IMPORTANT PRECAUTIONS

⚠ WARNING: To reduce the risk of serious injury, read the following important precautions before using the recumbent cycle.

1. Read all instructions in this manual before using the recumbent cycle.
2. It is the responsibility of the owner to ensure that all users of the recumbent cycle are adequately informed of all precautions. Use the recumbent cycle only as described in this manual.
3. Use the recumbent cycle indoors on a level surface. Keep the recumbent cycle away from moisture and dust. Place a mat under the recumbent cycle to protect the floor or carpet.
4. Inspect and tighten all parts regularly. Replace any worn parts immediately.
5. Keep children under the age of 12 and pets away from the recumbent cycle at all times.
6. The recumbent cycle should not be used by persons weighing more than 250 pounds.
7. Wear appropriate clothing when exercising; do not wear loose clothing that could become caught on the recumbent cycle. Always wear athletic shoes when using the recumbent cycle.
8. Always keep your back straight when using the recumbent cycle. Do not arch your back.
9. If you feel pain or dizziness while exercising, stop immediately and cool down.
10. The pulse sensor is not a medical device. Various factors, including the user's movement, may affect the accuracy of heart rate readings. The pulse sensor is intended only as an exercise aid in determining heart rate trends in general.
11. The recumbent cycle is intended for in-home use only. Do not use the recumbent cycle in a commercial, rental, or institutional setting.

⚠ WARNING: Before beginning this or any exercise program, consult your physician. This is especially important for persons over the age of 35 or persons with pre-existing health problems. Read all instructions before using. ICON assumes no responsibility for personal injury or property damage sustained by or through the use of this product.

BEFORE YOU BEGIN

Congratulations for selecting the new NordicTrack® TRL625 recumbent cycle. Cycling is one of the most effective exercises for increasing cardiovascular fitness, building endurance, and toning the entire body. The NordicTrack® TRL625 offers an impressive array of features designed to let you enjoy this healthful exercise in the comfort and privacy of your home.

For your benefit, read this manual carefully before you use the NordicTrack® TRL625. If you have additional questions, please call our Customer Service

Department toll-free at 1-888-825-2588, Monday through Friday, 6 a.m. until 6 p.m. Mountain Time (excluding holidays). To help us assist you, mention the product model number and serial number when calling. The model number is 831.298960. The serial number can be found on a decal attached to the recumbent cycle (see the front cover of this manual).

Before reading further, please familiarize yourself with the parts that are labeled in the drawing below.

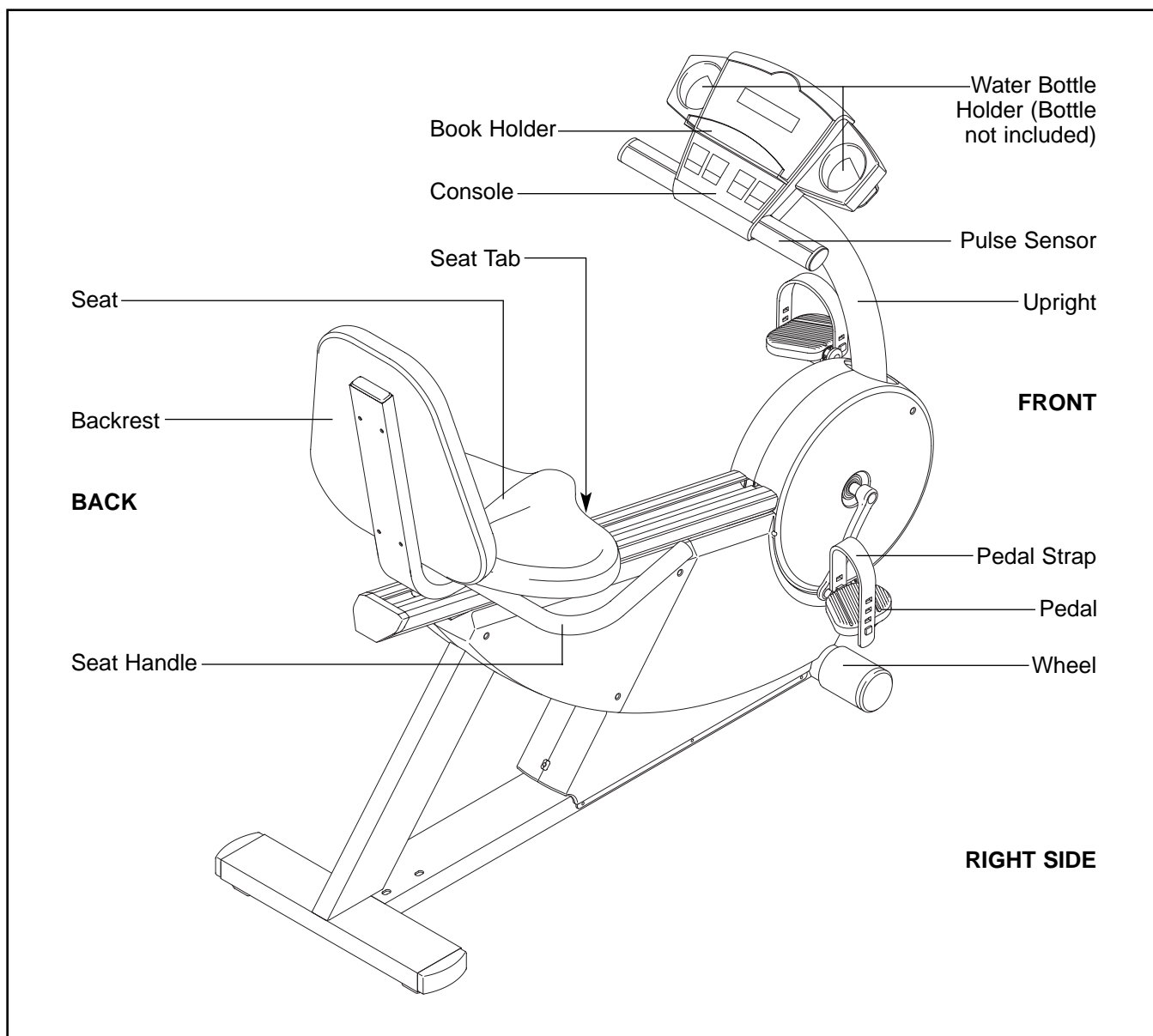

ASSEMBLY

Assembly requires two persons. Place all parts of the recumbent cycle in a cleared area and remove the packing materials. Do not dispose of the packing materials until assembly is completed.

Assembly requires the included tools and your own adjustable wrench .

Use the drawings below to identify the small parts used in assembly. The number in parenthesis below each drawing refers to the key number of the part, from the PART LIST on page 14. The second number refers to the quantity needed for assembly. **Note: Some small parts may have been pre-attached for shipping. If a part is not in the parts bag, check to see if it has been pre-assembled.**

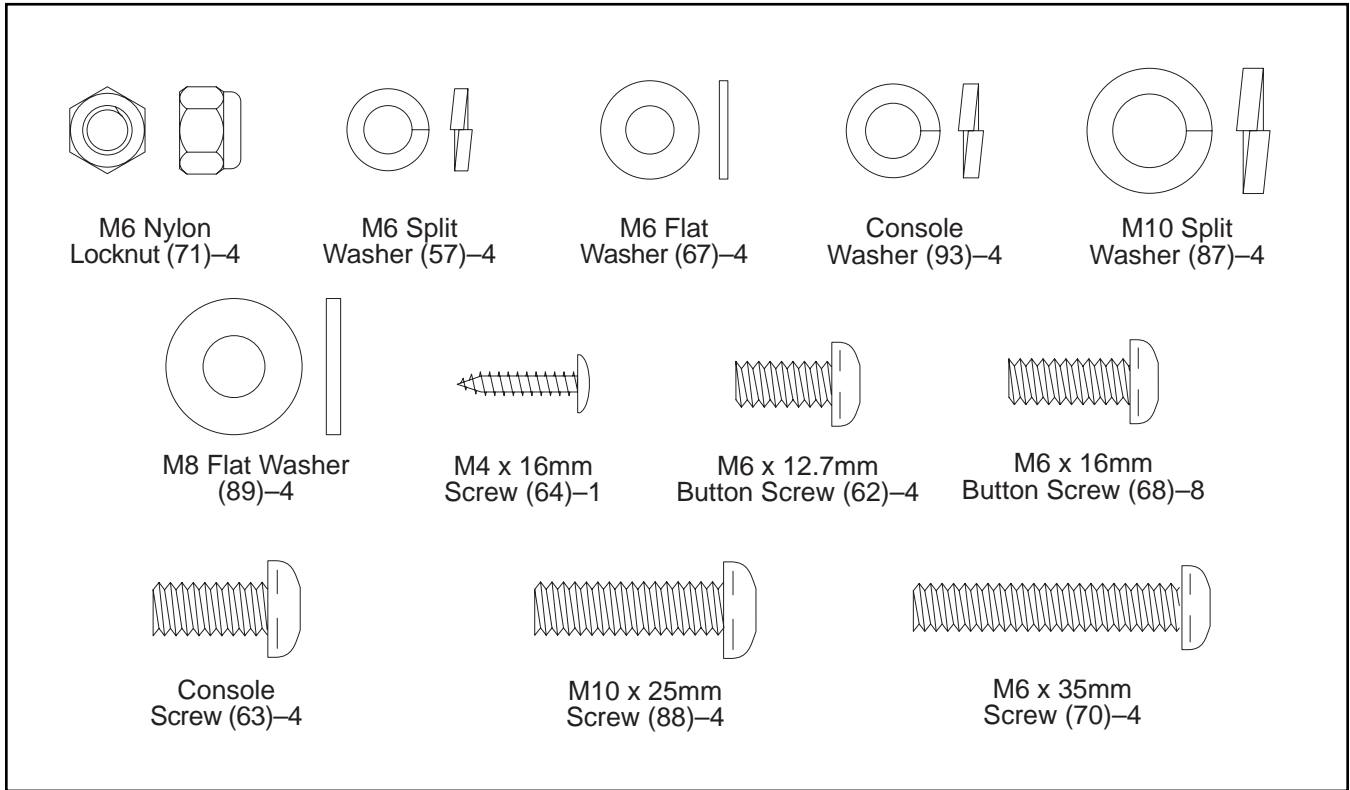

1. Attach the Stabilizer (8) to the Frame (1) with four M10 x 25mm Screws (88) and four M10 Split Washers (87).

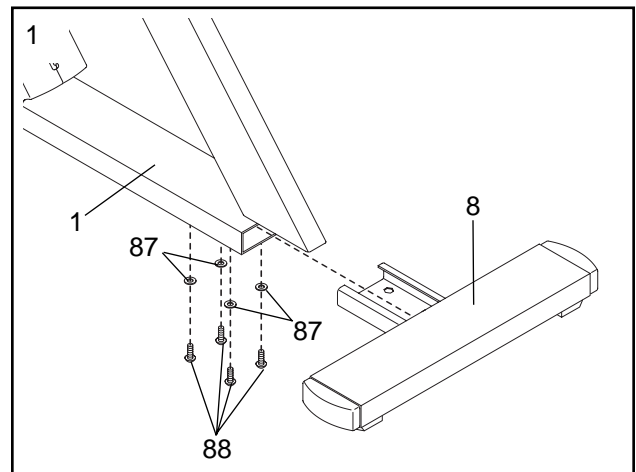

2. Connect the Extension Wire (66) to the Wire Harness (22). Attach the Upright (2) to the Frame (1) with four M6 x 12.7mm Button Screws (62), four M6 Split Washers (57), and four M6 Flat Washers (67).

Slide the Collar (91) onto the Upright (2). Align the slit in the Collar with the seam between the Side Shields (4, 5). Snap the Collar into the Side Shields.

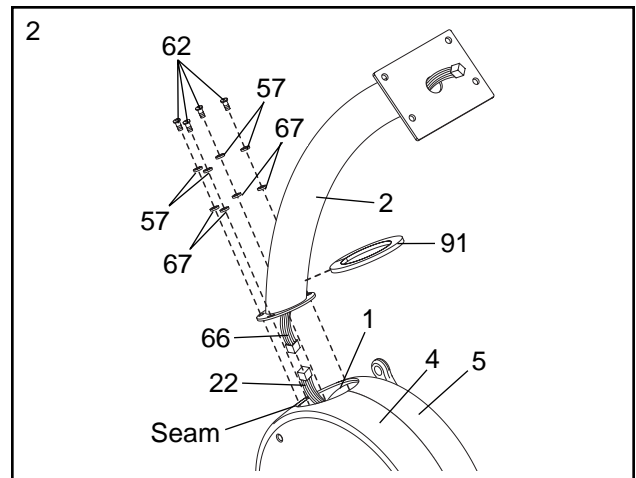

3. Connect the Extension Wire (66) to the console wire. Attach the Console (3) to the Upright (2) with four Console Washers (93) and four Console Screws (63). Snap the bookrack onto the Console as shown.

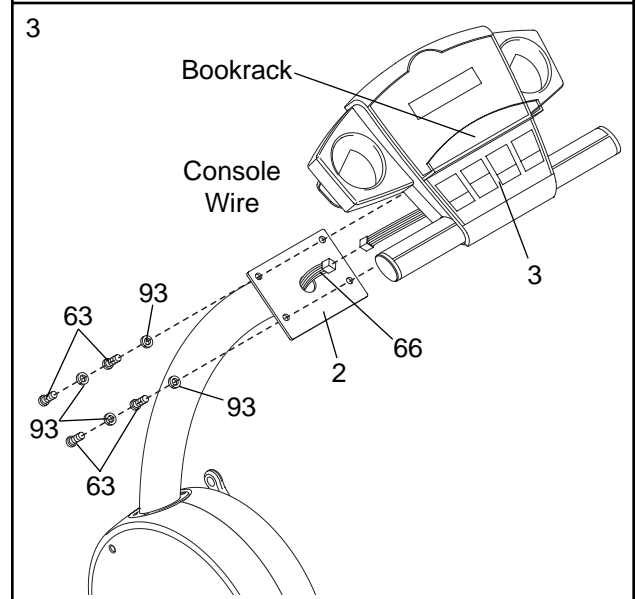

4. Attach the Left and Right Handlebars (11, 12) to the Seat Carriage (6) with four M6 x 35mm Screws (70) and four M6 Nylon Locknuts (71).

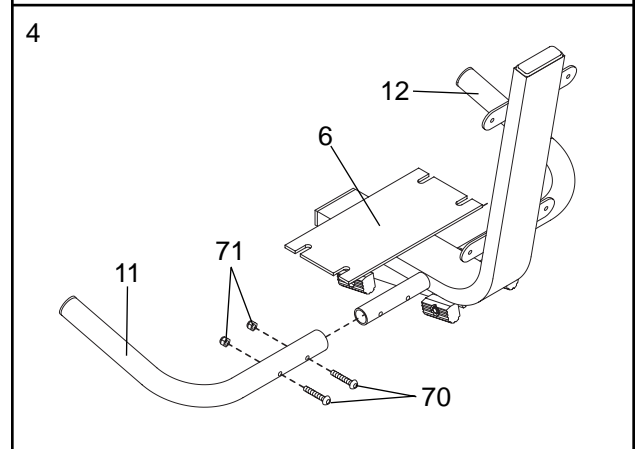

5. Attach the Seat (10) to the Seat Carriage (6) with four M6 x 16mm Button Screws (68) and four M8 Flat Washers (89).

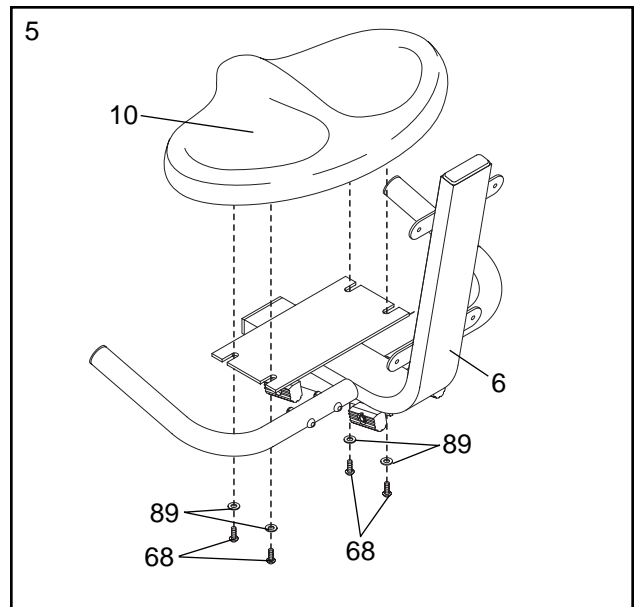

6. Attach the Seat Back (9) to the Seat Carriage (6) with four M6 x 16mm Button Screws (68).

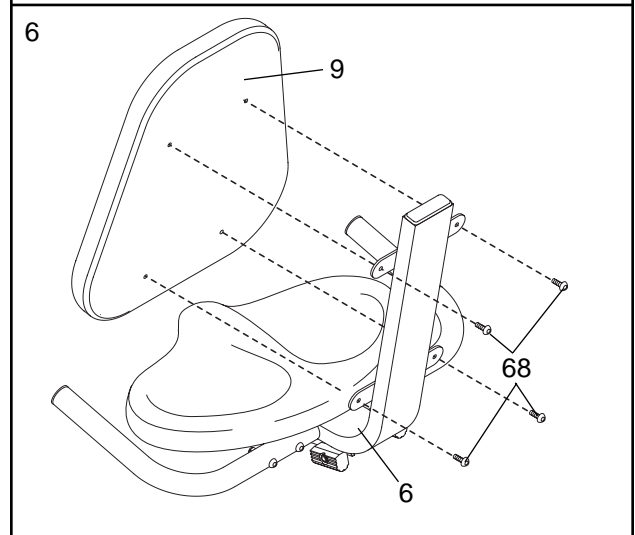

7. Hold the Seat Carriage (6) and lift the Seat Adjustment Tab (79). Slide the Seat Runners (72) into the Seat Frame (7).

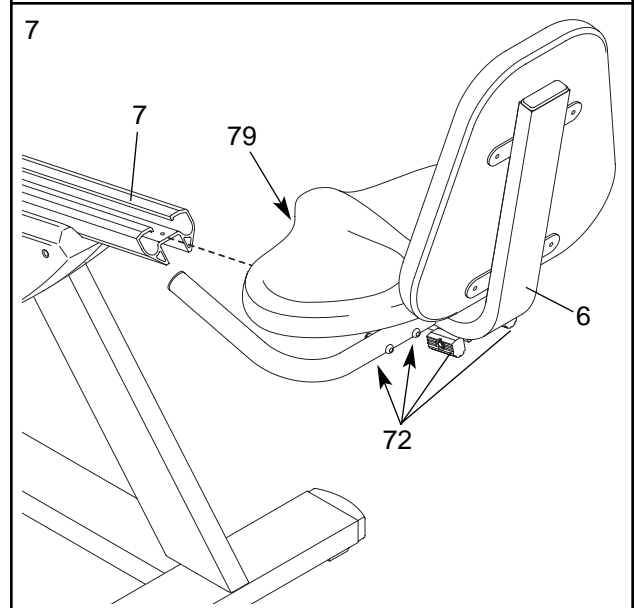

- Position the Seat Carriage (6) as shown. Insert the Seat Frame Cover (84) into the slot in the Seat Frame (7). The beveled end of the Seat Frame Cover should be flush with the end of the Seat Frame. Attach a Seat Stop (77) and the Seat Frame Cover to the Seat Frame with an M4 x 16mm Screw (64).

Push the Seat Frame Cap (13) into the end of the Seat Frame (7).

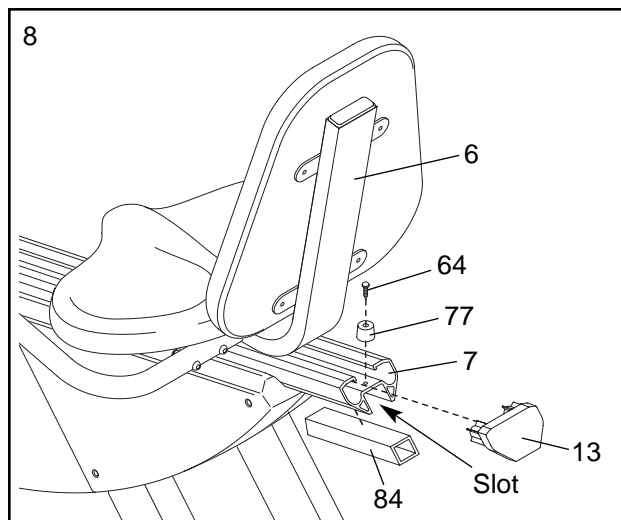

- Identify the Left Pedal (69) (there is an "L" on the Left Pedal for identification). Using an adjustable wrench, **firmly tighten** the Left Pedal *counterclockwise* into the Left Crank Arm (51). Tighten the Right Pedal (not shown) *clockwise* into the Right Crank Arm (not shown). **Tighten both Pedals as firmly as possible. Important: After using the recumbent cycle for one week, retighten the Pedals. For best performance, the Pedals must be kept properly tightened.**

Adjust the Left Pedal Strap (21) to the desired position, and press the end of the Strap onto the tab on the Left Pedal (69). Adjust the Right Pedal Strap (not shown) in the same way.

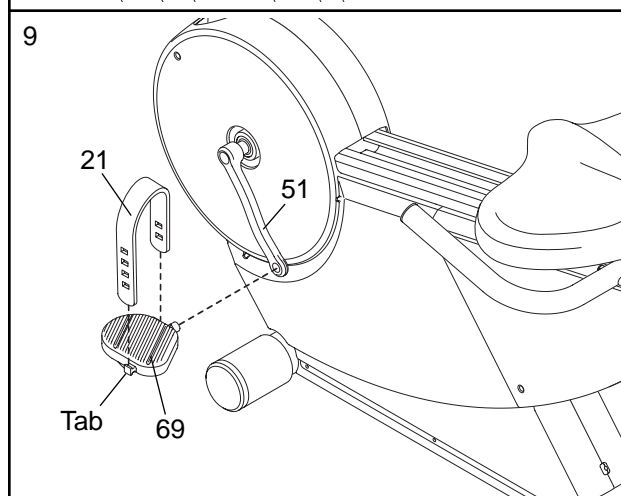

- Make sure that all parts are tightened before you use the recumbent cycle. Place a mat beneath the recumbent cycle to protect the floor.**

HOW TO OPERATE THE RECUMBENT CYCLE

FEATURES OF THE CONSOLE

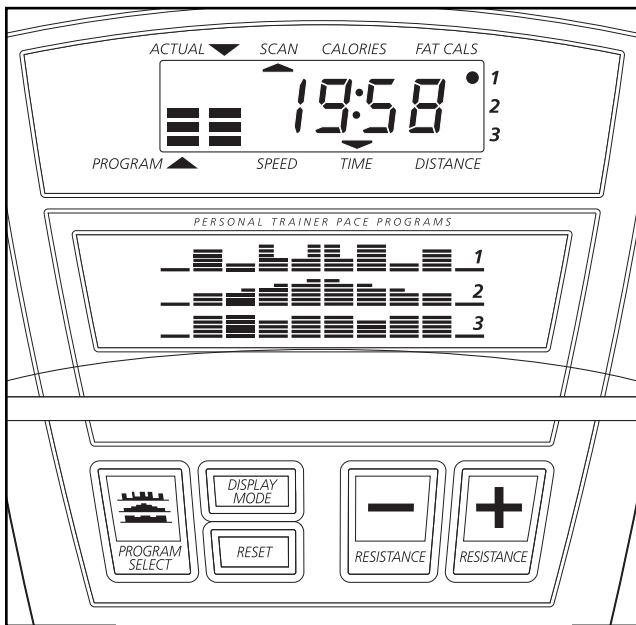

The easy-to-use console offers a manual mode and three personal trainer programs that pace your exercise for effective workouts. You can choose a stamina-building interval program, an aerobic program, or a special fat-burning program. To adjust the intensity of your exercise, you can change the pedal resistance at any time with a touch of a button. As you exercise, you can watch your progress on the console display. The display features six different modes:

Speed—When an arrow appears above the word **SPEED**, the console will display your pedaling speed.

Time—When an arrow appears above the word **TIME**, the console will display the elapsed time. Note: When a pace program is selected, the console will display the *time remaining* in the program.

Distance—When an arrow appears above the word **DISTANCE**, the console will display the distance you have pedaled.

Fat Calories—When an arrow appears below the words **FAT CALS**, the console will display the approximate number of *fat calories* you have burned (see **BURNING FAT** on page 13).

Calories—When an arrow appears below the word **CALORIES**, the console will display the approximate number of calories you have burned.

Scan—When an arrow appears below the word **SCAN**, the console will display all of the information above in a repeating cycle.

Pulse—When you use the pulse sensor, the console will display your heart rate. (See step 6 on page 10.)

HOW THE PACE PROGRAMS OPERATE

When you use a pace program, two columns of bars will appear in the display. The left column represents a target pace and the right column shows your actual pedaling pace. The target pace will change periodically during the program; as the target pace changes, simply adjust your pedaling pace to keep both columns at the same height. **Important: The target pace is a goal pace. Your actual pace may be slower than the target pace, especially during the first few months of your exercise program. Be sure to exercise at a pace that is comfortable for you.**

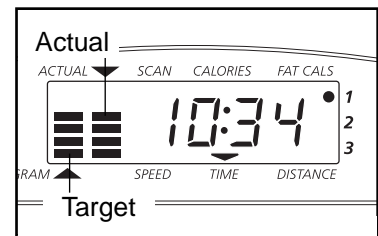

The three graphs on the console show how the target pace will change during the programs. For example, during the aerobic program (program 2), the graph shows that the target pace will gradually increase during the first half of the program, and then gradually decrease during the last half. Each program will last for twenty minutes.

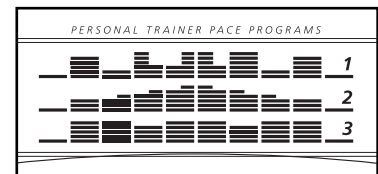

STEP-BY-STEP CONSOLE OPERATION

The innovative recumbent cycle requires no batteries or external power source. Instead, power is supplied by a generator as you pedal. Note: To operate the resistance buttons, you must pedal at a pace of about 30 revolutions per minute (rpm) or faster.

1 Begin pedaling

To activate the console, simply begin pedaling. After a few seconds, the entire display will appear for two seconds; the console will then be ready for use.

2 Select one of the three pace programs or the manual mode

To select one of the pace programs, repeatedly press the Program Select button.

The program indicator will show which program you have selected. To select the manual mode, press the Program Select button until the program indicator disappears. The programs will be selected in the following order: program 1 (interval), program 2 (aerobic), program 3 (fat burn), manual mode.

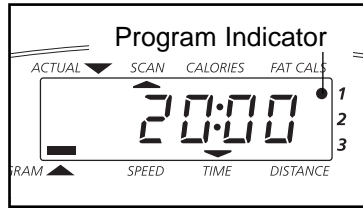

The speed, time, distance, fat calorie, or calorie mode—

Repeatedly press the Display Mode button until an arrow appears below or above the name of the desired mode. Make sure that there is not an arrow under the word SCAN.

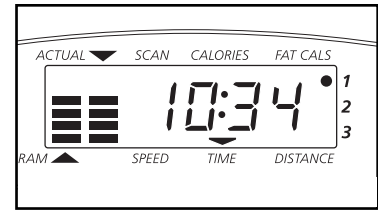

The pulse mode—To use the pulse mode, see step 6.

To reset the display, press the reset button.

3 Begin your workout

If you selected the manual mode, go to step 4. If you selected one of the pace programs, two columns of

bars will appear in the display. The left column will show one bar, indicating a relatively slow pace. The right column will show your actual pedaling pace. Adjust your pedaling pace until only one bar appears in the right column. Each time the target pace changes during the program, adjust your pedaling pace to keep both columns at the same height.

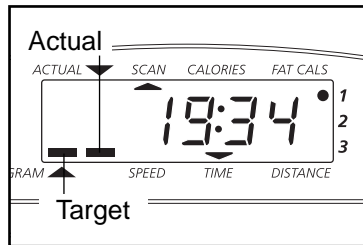

5 Change the pedal resistance as desired

To change the pedal resistance, press the resistance + and – buttons. **Important: You must pedal at a pace of about 30 rpm or faster for the resistance buttons to operate. If the pedal resistance does not change when a resistance button is pressed, the resistance may have reached the maximum or minimum setting.** Note: When you finish exercising, the pedal resistance will remain at the same setting until the next workout.

6 Measure your heart rate if desired

Important: If there are thin sheets of plastic on the metal contacts on the pulse sensor, remove the plastic before using the pulse sensor.

To use the pulse sensor, place your hands on the metal contacts. Your palms must be resting on the front contacts and your fingers

must be touching the rear contacts. Avoid moving your hands. After a moment, a heart-shaped indicator in the display will begin to flash and your heart rate will be shown. For the most accurate reading, continue to hold the contacts for about 15 seconds.

Make sure that your hands are positioned as described, and that you are not moving your hands excessively or squeezing the metal contacts too tightly.

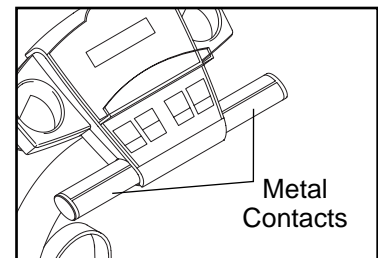

4 Follow your progress with the console display

The scan mode—

Repeatedly press the Display Mode button until an arrow appears under the word SCAN. When the scan mode is selected, the console will display your pedaling speed, the elapsed time, the distance you have pedaled, and the numbers of fat calories and calories you have burned. A second arrow will show which mode is currently displayed. Each mode will be displayed for five seconds.

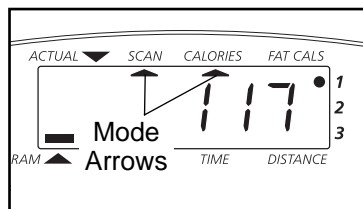

7 Turn off the console

To turn off the console, simply stop pedaling. If the pedals are not moved, the console will turn off automatically after one to two minutes.

HOW TO ADJUST THE PEDAL STRAPS

To adjust the pedal straps, first pull the straps off the tabs on the pedals. Move the straps to the desired position and press the straps back onto the tabs.

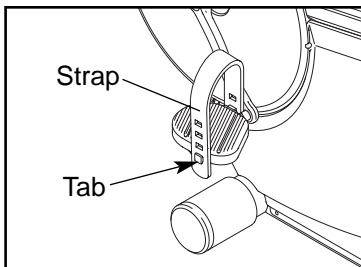

HOW TO ADJUST THE POSITION OF THE SEAT

For effective exercise, the seat should be in the proper position. As you pedal, there should be a slight bend in your knees when the pedals are the farthest away. To adjust the seat, first lift the seat tab in front of the seat. Next, slide the seat to the desired position and release the seat tab.

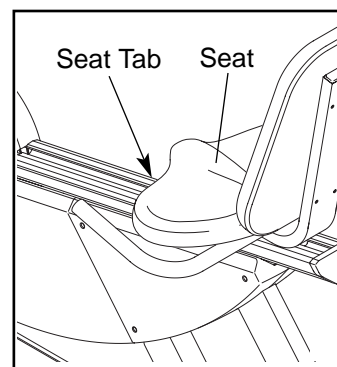

Important: After you adjust the position of the seat, make sure that your knees will not hit the console when you pedal.

MAINTENANCE AND TROUBLE-SHOOTING

Inspect and tighten all parts of the recumbent cycle regularly. To clean the recumbent cycle, use a soft, damp cloth. To prevent damage to the console, **keep liquids away from the console and keep the console out of direct sunlight.**

PULSE SENSOR TROUBLE-SHOOTING

- Avoid moving your hands while using the pulse sensor. Excessive movement may interfere with heart rate readings.
- Do not hold the metal contacts too tightly; doing so may interfere with heart rate readings.
- For the most accurate heart rate reading, hold the metal contacts for about 15 seconds.
- For optimal performance of the pulse sensor, keep the metal contacts clean. The contacts can be cleaned with a soft cloth—never use alcohol, abrasives, or chemicals.

EXERCISE GUIDELINES

⚠ WARNING: Before beginning this or any exercise program, consult your physician. This is especially important for individuals over the age of 35 or individuals with pre-existing health problems.

The pulse sensor is not a medical device. Various factors may affect the accuracy of heart rate readings. The pulse sensor is intended only as an exercise aid in determining heart rate trends in general.

The following guidelines will help you to plan your exercise program. Remember that proper nutrition and adequate rest are essential for successful results.

EXERCISE INTENSITY

Whether your goal is to burn fat or to strengthen your cardiovascular system, the key to achieving the desired results is to exercise with the proper intensity. The proper intensity level can be found by using your heart rate as a guide. The chart below shows recommended heart rates for fat burning, maximum fat burning, and cardiovascular (aerobic) exercise.

165	155	145	140	130	125	115	♥
145	138	130	125	118	110	103	♥
125	120	115	110	105	95	90	♥
<hr/>							
20	30	40	50	60	70	80	

To find the proper heart rate for you, first find your age at the bottom of the chart (ages are rounded off to the nearest ten years). Next, find the three numbers above your age; the three numbers are your “training zone.” The lowest number is the recommended heart rate for fat burning; the middle number is the recommended heart rate for maximum fat burning; and the highest number is the heart rate for aerobic exercise.

Fat Burning

To burn fat effectively, you must exercise at a relatively low intensity level for a sustained period of time.

During the first few minutes of exercise, your body uses easily accessible *carbohydrate* calories for energy. Only after the first few minutes of exercise does your body begin to use stored *fat* calories for energy. If your goal is to burn fat, adjust the intensity of your exercise until your heart rate is near the lowest number or the middle number in your training zone as you exercise.

Aerobic Exercise

If your goal is to strengthen your cardiovascular system, your exercise must be “aerobic.” Aerobic exercise is activity that requires large amounts of oxygen for prolonged periods of time. This increases the demand on the heart to pump blood to the muscles, and on the lungs to oxygenate the blood. For aerobic exercise, adjust the intensity of your exercise until your heart rate is near the highest number in your training zone.

WORKOUT GUIDELINES

Each workout should include the following three parts:

A warm-up, consisting of 5 to 10 minutes of stretching and light exercise. A proper warm-up increases your body temperature, heart rate, and circulation in preparation for exercise.

Training zone exercise, consisting of 20 to 30 minutes of exercising with your heart rate in your training zone. (During the first few weeks of your exercise program, do not keep your heart rate in your training zone for longer than 20 minutes.)

A cool-down, with 5 to 10 minutes of stretching. This will increase the flexibility of your muscles and will help to prevent post-exercise problems.

EXERCISE FREQUENCY

To maintain or improve your condition, plan three workouts each week, with at least one day of rest between workouts. After a few months of regular exercise, you may complete up to five workouts each week, if desired.

The key to success is make exercise a regular and enjoyable part of your everyday life.

EXPLODED DRAWING—Model No. 831.298960

R0901A

Key No.	Qty.	Description	Key No.	Qty.	Description	Key No.	Qty.	Description
1	1	Frame	33	6	M6 Nut	65	1	M10 Flat Washer
2	1	Upright	34	3	M10 Locknut	66	1	Extension Wire
3	1	Console	35	2	Flywheel Spacer	67	4	M6 Flat Washer
4	1	Left Side Shield	36	1	M8 x 41mm Bolt	68	8	M6 x 16mm Button Screw
5	1	Right Side Shield	37	2	Wheel Bushing	69	1	Left Pedal
6	1	Seat Carriage	38	2	Wheel	70	4	M6 x 35mm Screw
7	1	Seat Frame	39	3	Wheel Washer	71	8	M6 Nylon Locknut
8	1	Rear Stabilizer	40	4	Push Nut	72	4	Seat Runner
9	1	Seat Back	41	2	Wheel Cover	73	1	Stop Bracket
10	1	Seat	42	1	Wheel Axle	74	2	Endcap
11	1	Left Handlebar	43	1	M10 x 45mm Bolt	75	2	Handlebar Endcap
12	1	Right Handlebar	44	1	Idler Bracket	76	8	M4 x 25mm Screw
13	1	Seat Frame Cap	45	1	M8 x 70mm Bolt	77	2	Seat Stop
14	2	Foot	46	1	M4 x 16mm Round Screw	78	1	Seat Spring
15	2	Stabilizer Endcap	47	1	Adjustment Bracket	79	1	Seat Adjustment Tab
16	6	M4 x 16mm Flat Screw	48	1	Idler Wheel	80	4	Offset Pin
17	1	Flywheel	49	1	Pulley	81	1	Control Board
18	1	"C" Magnet	50	1	Right Crank Arm	82	1	M6 x 35mm Screw
19	1	Right Pedal	51	1	Left Crank Arm	83	1	Seat Frame Shield
20	1	Right Pedal Strap	52	1	Crank	84	1	Seat Frame Cover
21	1	Left Pedal Strap	53	2	Crank Cap	85	1	Brake Pad
22	1	Motor/Wire Harness	54	2	M8 x 20mm Flange Screw	86	4	Generator Bolt
23	1	Resistance Cable	55	2	Snap Ring	87	4	M10 Split Washer
24	1	M8 Nylon Locknut	56	3	Crank Bearing	88	4	M10 x 25mm Screw
25	1	Resistance Spring	57	4	M6 Split Washer	89	4	M8 Flat Washer
26	1	Generator Assembly	58	1	Clutch Bearing	90	1	Belt
27	2	Flywheel Bearing	59	1	Magnet	91	1	Collar
28	1	Flywheel Axle	60	1	Reed Switch Clamp	92	1	Pulley Washer
29	2	Eye Bolt	61	1	Reed Switch	93	4	Console Washer
30	2	Tension Bracket	62	4	M6 x 12.7 mm Button Screw	#	1	User's Manual
31	2	Flange Nut	63	4	Console Screw	#	1	Allen Wrench
32	1	M6 x 38mm Bolt	64	22	M4 x 16mm Screw			

Note: "#" indicates a non-illustrated part. Specifications are subject to change without notice. See the back cover of this manual for information about ordering replacement parts.

HOW TO ORDER REPLACEMENT PARTS

To order replacement parts, simply call our Customer Service Department toll-free at 1-888-825-2588, Monday through Friday, 6 a.m. until 6 p.m. Mountain Time (excluding holidays). To help us assist you, please be prepared to give the following information when calling:

- The MODEL NUMBER of the product (831.298960)
- The NAME of the product (NordicTrack® TRL625 recumbent cycle)
- The SERIAL NUMBER of the product (see the front cover of this manual)
- The KEY NUMBER and DESCRIPTION of the part(s) from page 14 of this manual.

LIMITED WARRANTY

ICON Health & Fitness, Inc. (ICON), warrants this product to be free from defects in workmanship and material, under normal use and service conditions, for a period of ninety (90) days from the date of purchase. This warranty extends only to the original purchaser. ICON's obligation under this warranty is limited to replacing or repairing, at ICON's option, the product through one of its authorized service centers. All repairs for which warranty claims are made must be pre-authorized by ICON. This warranty does not extend to any product or damage to a product caused by or attributable to freight damage, abuse, misuse, improper or abnormal usage or repairs not provided by an ICON authorized service center, products used for commercial or rental purposes, or products used as store display models. No other warranty beyond that specifically set forth above is authorized by ICON.

ICON is not responsible or liable for indirect, special or consequential damages arising out of or in connection with the use or performance of the product or damages with respect to any economic loss, loss of property, loss of revenues or profits, loss of enjoyment or use, costs of removal, installation or other consequential damages of whatsoever nature. Some states do not allow the exclusion or limitation of incidental or consequential damages. Accordingly, the above limitation may not apply to you.

The warranty extended hereunder is in lieu of any and all other warranties and any implied warranties of merchantability or fitness for a particular purpose is limited in its scope and duration to the terms set forth herein. Some states do not allow limitations on how long an implied warranty lasts. Accordingly, the above limitation may not apply to you.

This warranty gives you specific legal rights. You may also have other rights which vary from state to state.

ICON HEALTH & FITNESS, INC., 1500 S. 1000 W., LOGAN, UT 84321-9813