

NordicTrack[®] *SL 528*

Model No. 30506.0

Serial No. _____

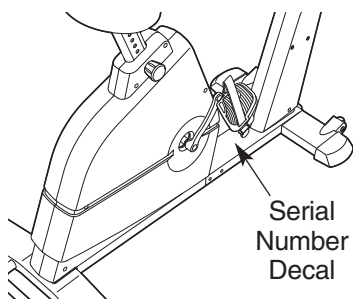

USER'S MANUAL

QUESTIONS?

As a manufacturer, we are committed to providing complete customer satisfaction. If you have questions, or if there are missing parts, please call:

1-888-936-4266

Mon.–Fri. 8:00 until 17:00 EST
(excluding holidays).

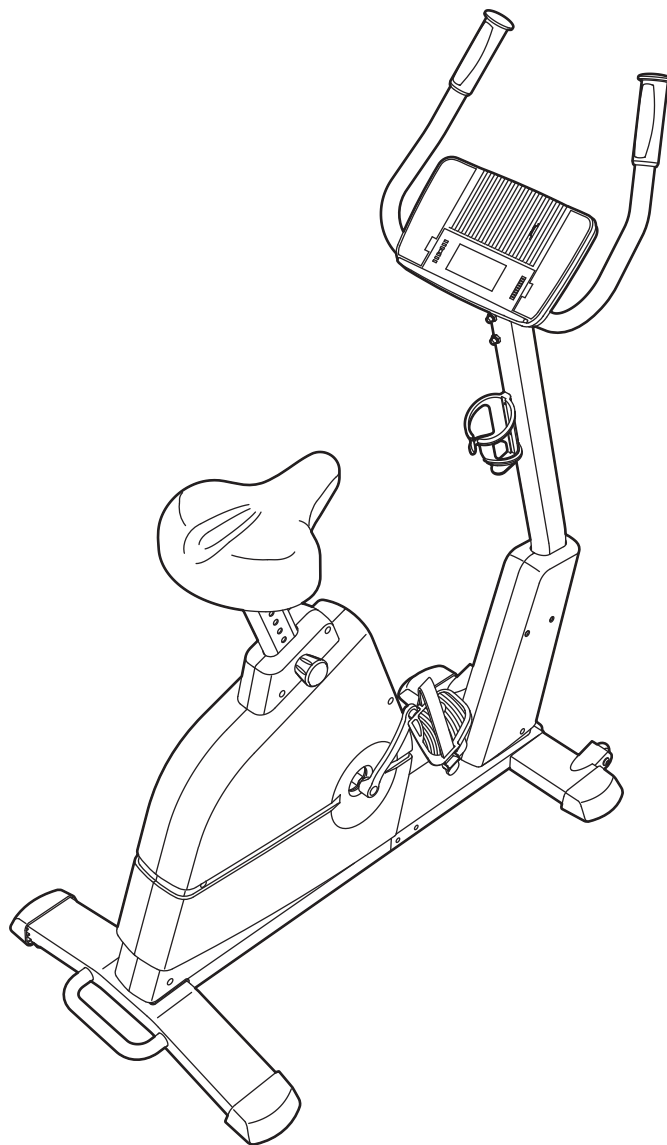

CAUTION

Read all precautions and instructions in this manual before using this equipment. Keep this manual for future reference.



Visit our website at

www.nordictrack.com



TABLE OF CONTENTS

IMPORTANT PRECAUTIONS3
BEFORE YOU BEGIN4
ASSEMBLY5
HOW TO OPERATE THE EXERCISE CYCLE9
MAINTENANCE AND TROUBLESHOOTING20
CONDITIONING GUIDELINES21
PART LIST22
EXPLODED DRAWING23
HOW TO ORDER REPLACEMENT PARTSBack Cover
LIMITED WARRANTYBack Cover

IMPORTANT PRECAUTIONS

⚠️ WARNING: To reduce the risk of serious injury, read the following important precautions before using the exercise cycle.

1. Read all instructions in this manual and all warnings on the exercise cycle before using the exercise cycle.
2. Use the exercise cycle only as described in this manual.
3. It is the responsibility of the owner to ensure that all users of the exercise cycle are adequately informed of all precautions.
4. The exercise cycle is intended for home use only. Do not use the exercise cycle in a commercial, rental, or institutional setting.
5. Keep the exercise cycle indoors, away from moisture and dust. Place the exercise cycle on a level surface, with a mat beneath it to protect the floor or carpet. Make sure that there is enough clearance around the exercise cycle to mount, dismount, and use the exercise cycle.
6. Inspect and properly tighten all parts regularly. Replace any worn parts immediately.
7. Keep children under the age of 12 and pets away from the exercise cycle at all times.
8. Wear appropriate clothes when exercising; do not wear loose clothes that could become caught on the exercise cycle. Always wear athletic shoes for foot protection.
9. The exercise cycle should not be used by persons weighing more than 115 kg (250 lbs.).
10. The pulse sensor is not a medical device. Various factors, including the user's movement, may affect the accuracy of heart rate readings. The pulse sensor is intended only as an exercise aid in determining heart rate trends in general.
11. Always keep your back straight when using the exercise cycle; do not arch your back.
12. If you feel pain or dizziness while exercising, stop immediately and cool down.
13. The decal shown below has been placed on the exercise cycle. If the decal is missing, or if it is not legible, please call the toll-free telephone number on the front cover of this manual and order a free replacement decal. Apply the decal in the location shown.

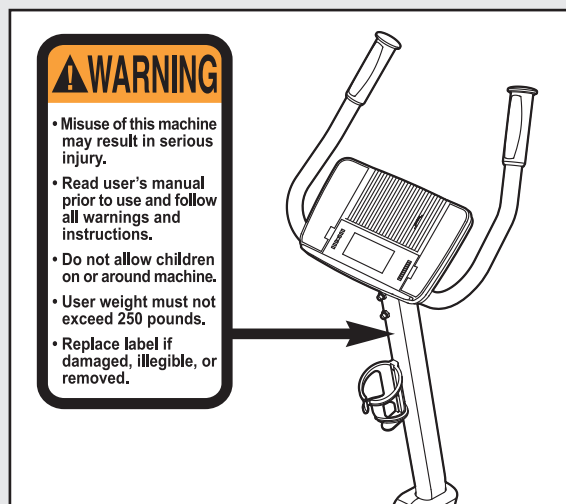

⚠️ WARNING: Before beginning this or any exercise program, consult your physician. This is especially important for persons over the age of 35 or persons with pre-existing health problems. Read all instructions before using. ICON assumes no responsibility for personal injury or property damage sustained by or through the use of this product.

BEFORE YOU BEGIN

Congratulations for selecting the new NordicTrack® SL 528 exercise cycle. Cycling is one of the most effective exercises for increasing cardiovascular fitness, building endurance, and toning the entire body. The SL 528 exercise cycle offers an impressive array of features to let you enjoy this healthful exercise in the convenience and privacy of your home.

For your benefit, read this manual carefully before you use the exercise cycle. If you have questions

after reading this manual, see the front cover of this manual. To help us assist you, please note the product model number and serial number before calling. The model number is 30506.0. The serial number can be found on a decal attached to the exercise cycle (see the front cover of this manual).

Before reading further, please familiarize yourself with the parts that are labeled in the drawing below.

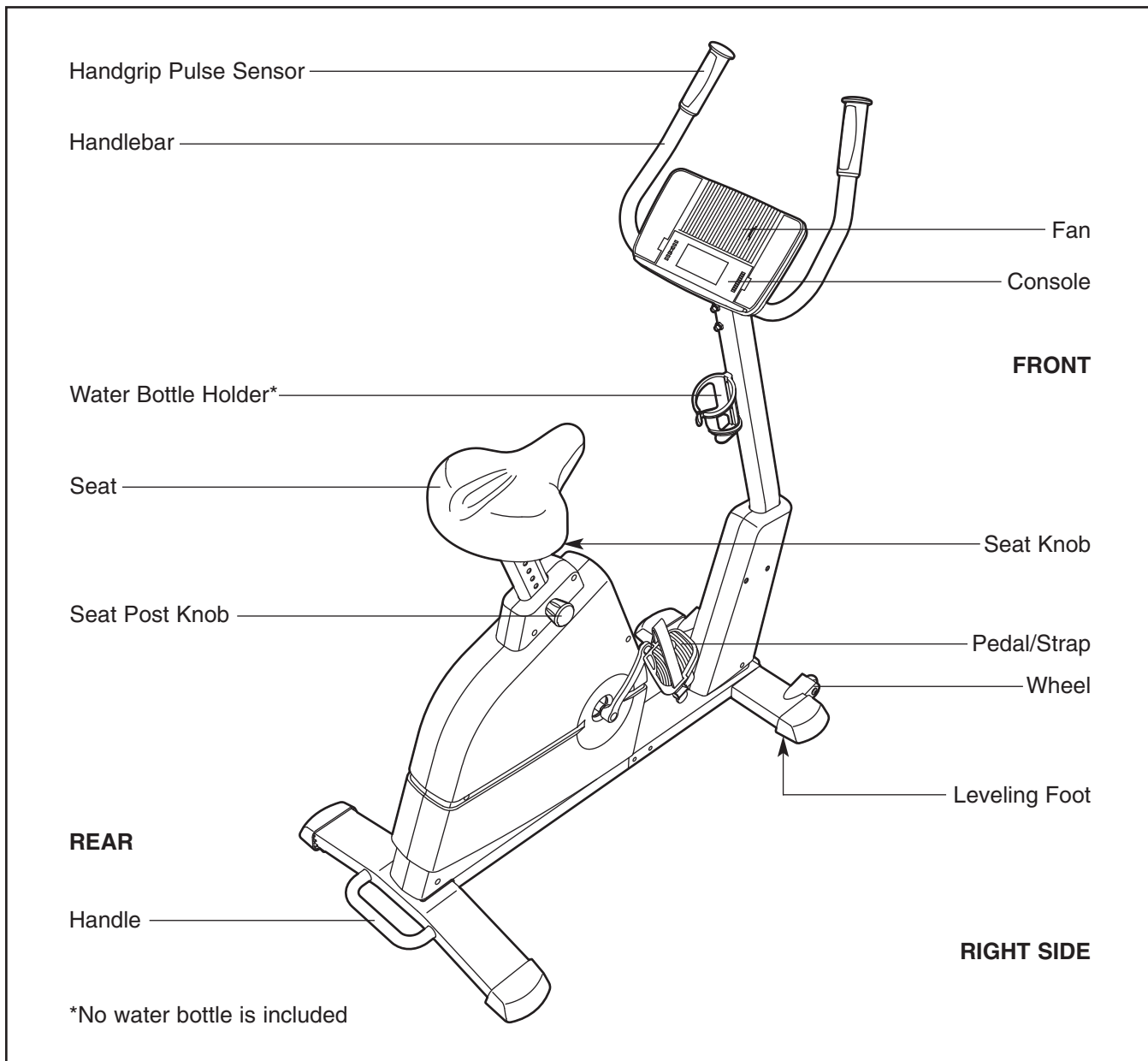

ASSEMBLY

Assembly requires two persons. Place all parts of the exercise cycle in a cleared area and remove the packing materials. Do not dispose of the packing materials until assembly is completed.

Assembly requires the included tools and your own adjustable wrench  **and Phillips screwdriver** .

Use the part drawings below to identify the small parts used in assembly. The number in parentheses below each drawing is the key number of the part, from the PART LIST on page 22. The number following the parentheses is the quantity needed for assembly. **Note: Some small parts may have been pre-attached. If a part is not in the parts bag, check to see if it has been pre-attached.**

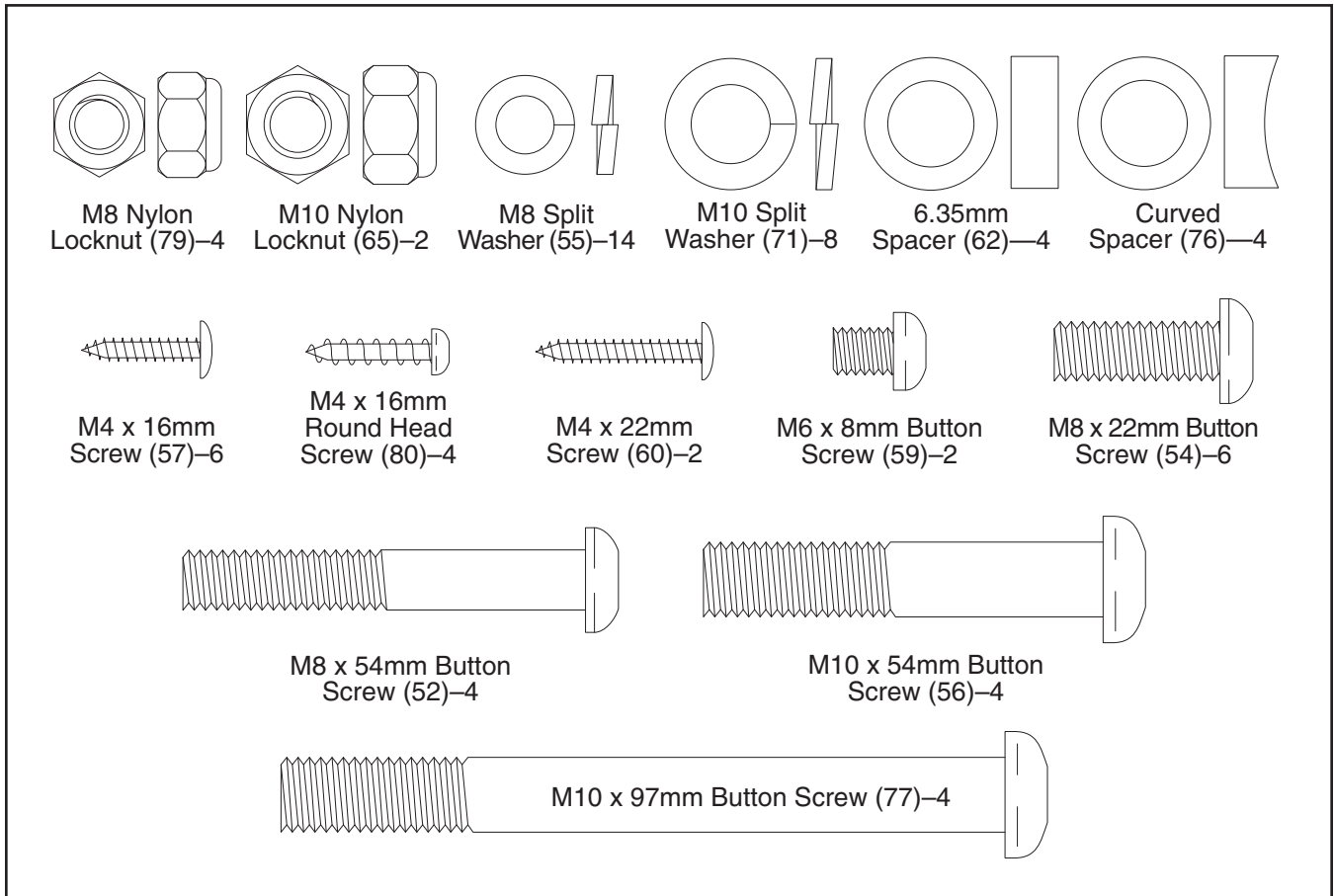

1. Attach the Left Front Stabilizer (15) to the left side of the Upright Frame (5) with three M8 x 22mm Button Screws (54) and three M8 Split Washers (55). **Make sure that the Left Front Stabilizer is turned so the Wheel (17) is facing forward as shown.**

Attach the Right Front Stabilizer (40) to the right side of the Upright Frame (5) in the same way.

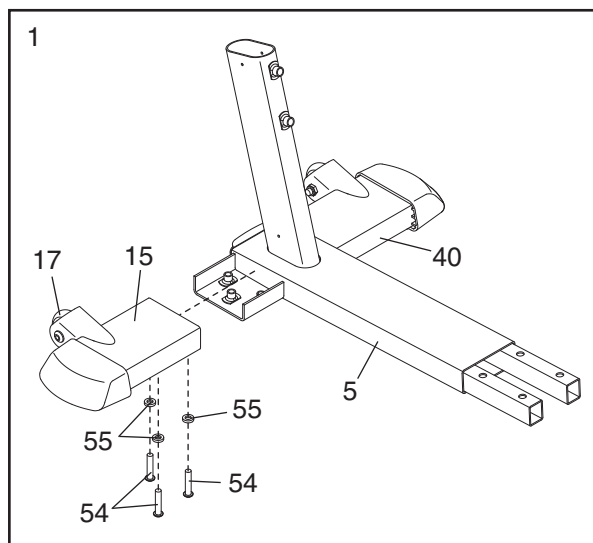

2. While another person lifts the rear of the Frame (1), attach the Rear Stabilizer (16) to the Frame with four M8 x 54mm Button Screws (52) and four M8 Split Washers (55).

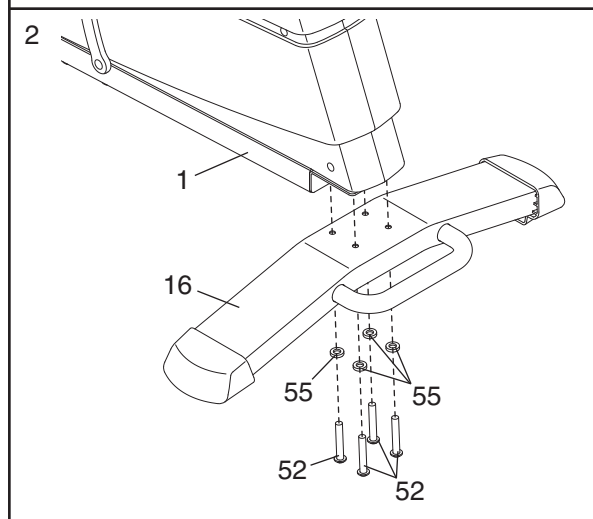

3. While another person lifts the front of the Frame (1), connect the Middle Wire Harness (51) to the Lower Wire Harness (43). Next, slide the Upright Frame (5) into the Frame. **Be careful to avoid pinching the Wire Harnesses (51, 43).**

Attach the Upright Frame (5) to the Frame (1) with four M10 x 54mm Button Screws (56), four 6.35mm Spacers (62), and four M10 Split Washers (71).

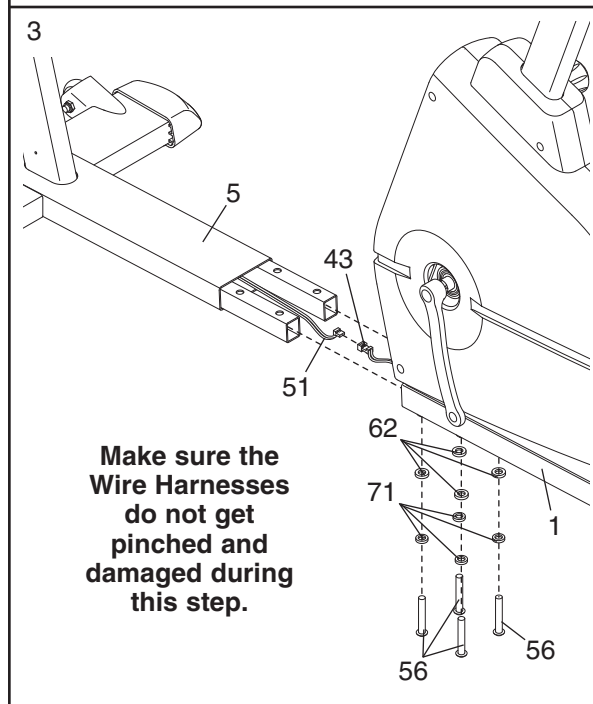

- While another person holds the Upright (2) near the Upright Frame (5), connect the Upper Wire Harness (42) to the Middle Wire Harness (51). **Next, gently pull the upper end of the Upper Wire Harness to remove the slack from the Wire Harnesses while inserting the Upright into the Upright Frame. Be careful to avoid pinching the Wire Harnesses.**

Attach the Upright (2) to the Upright Frame (5) with two M10 x 97mm Button Screws (77), two M10 Split Washers (71), and two Curved Spacers (76). **Make sure that the concave end of each Curved Spacer is facing the Frame. Be careful to avoid damaging the Wire Harnesses (42, 51).**

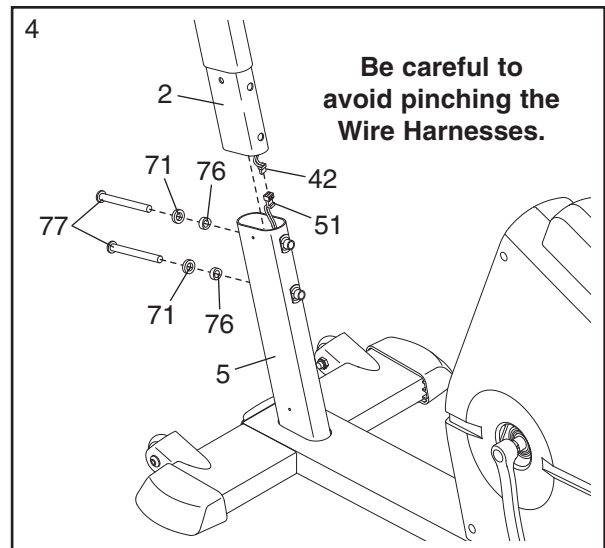

- Attach the Left Front Side Shield (13) to the left side of the Upright Frame (5) with two M4 x 16mm Screws (57). Attach the Right Front Side Shield (14) to the right side of the Upright Frame in the same way. Next, attach the Left Front Side Shield to the Right Front Side Shield with two M4 x 16mm Screws (57).

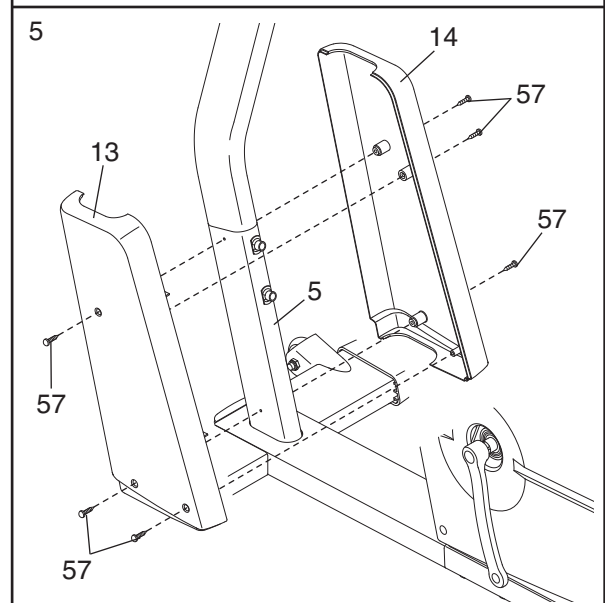

- Pull the Upper Wire Harness (42) up through the Handlebar (3) while inserting the Handlebar into the Upright (2). **Be careful to avoid pinching the Upper Wire Harness.**

Attach the Handlebar (3) to the Upright (2) with two M10 x 97mm Button Screws (77), two M10 Split Washers (71), two Curved Spacers (76), and two M10 Nylon Locknuts (65). **Make sure that the concave end of each Curved Spacer is turned toward the Frame. Be careful to avoid damaging the Upper Wire Harness (42).**

Attach the Water Bottle Holder (74) to the Upright (2) with two M4 x 22mm Screws (60).

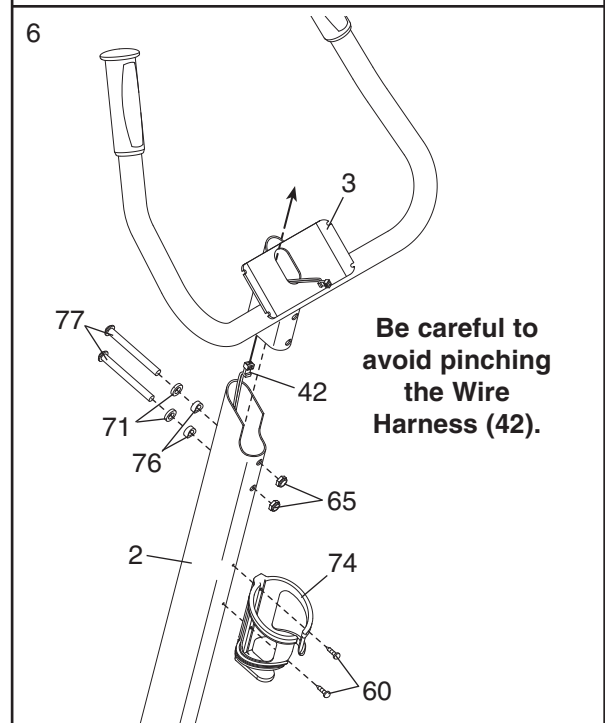

7. The Console (4) requires four “D” batteries (not included); alkaline batteries are recommended. Remove the battery cover from the bottom of the Console. Next, insert four batteries into the battery compartment; **make sure that the batteries are oriented as shown by the diagram inside the battery compartment.** Reattach the battery cover.

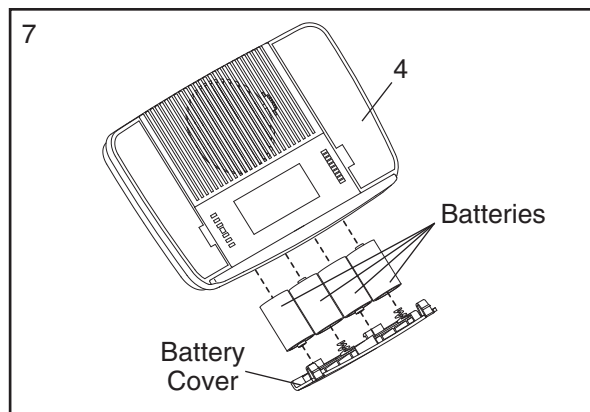

8. While another person holds the Console (4) near the Handlebar (3), connect the Upper Wire Harness (42) to the wire harness on the Console, and connect the Pulse Wire (75) to the pulse wire on the Console. Insert the excess wiring into the Upright (2).

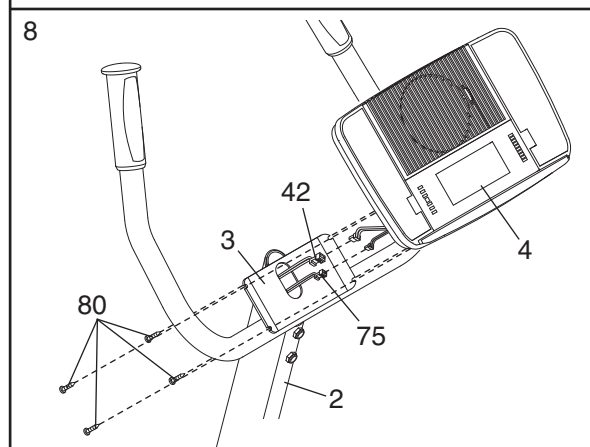

Attach the Console (4) to the Handlebar (3) with four M4 x 16mm Round Head Screws (80). **Be careful to avoid pinching the wires and wire harnesses.**

9. Thread an M6 x 8mm Button Screw (59) into the front hole in the Seat Post (8). Next, orient the Seat Carriage (11) as shown, and slide it onto the Seat Post. Thread the other M6 x 8mm Button Screw into the rear hole in the Seat Post.

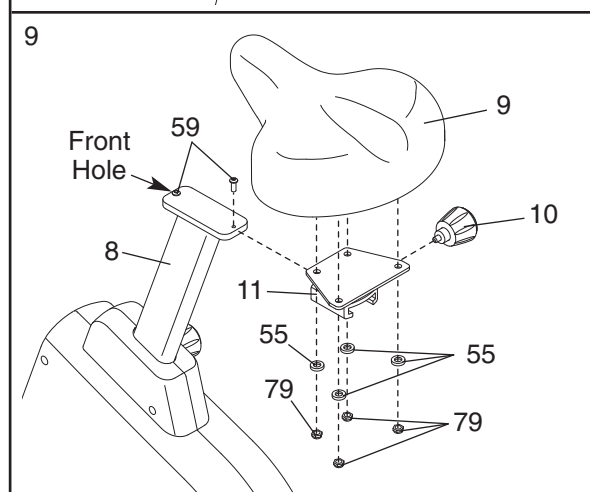

Next, attach the Seat (9) to the Seat Carriage (11) with four M8 Nylon Locknuts (79) and four M8 Split Washers (55). (Note: The Nylon Locknuts and the Split Washers may be pre-attached to the Seat.) Thread the Seat Knob (10) clockwise into the right side of the Seat Carriage until it is tight.

10. Identify the Left Pedal (22), which is marked with an “L.” Using an adjustable wrench, **firmly tighten** the Left Pedal *counterclockwise* into the Left Crank Arm (24). Tighten the Right Pedal (not shown) *clockwise* into the Right Crank Arm (not shown). **Important: Tighten both Pedals as firmly as possible. After using the exercise cycle for one week, retighten the Pedals.**

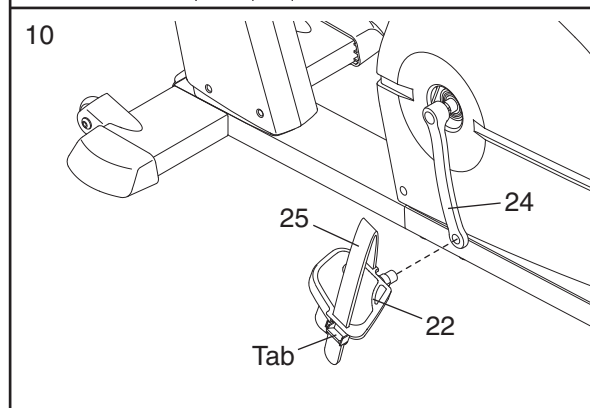

Adjust the Left Pedal Strap (25) to the desired position, and press the end of the Left Pedal Strap onto the tab on the Left Pedal (22). Adjust the Right Pedal Strap (not shown) in the same way.

11. **Make sure that all parts are properly tightened before you use the exercise cycle.** Note: After assembly is completed, some extra parts may be left over. Place a mat beneath the exercise cycle to protect the floor.

HOW TO OPERATE THE EXERCISE CYCLE

HOW TO ADJUST THE PEDAL STRAPS

To adjust the pedal straps, first pull the ends of the straps off the tabs on the pedals. Adjust the straps to the desired position, and then press the ends of the straps back onto the tabs.

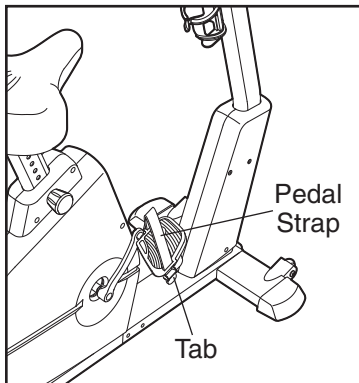

HOW TO ADJUST THE SEAT POST

For effective exercise, the seat should be at the proper height. As you pedal, there should be a slight bend in your knees when the pedals are in the lowest position. To adjust the height of the seat, first turn the seat post knob counterclockwise

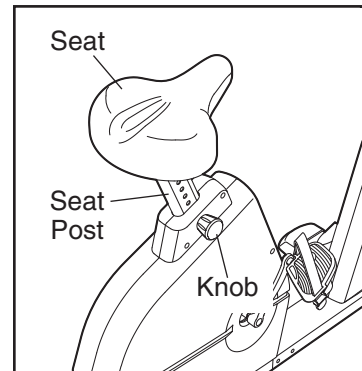

two or three turns to loosen it (if the knob is not loosened enough, it may scratch the seat post). Next, pull the knob, slide the seat post to the desired height, and then release the knob. **Move the seat post up and down slightly until the pin on the knob snaps into one of the holes in the seat post.** Then, turn the knob clockwise until it is tight.

HOW TO ADJUST THE SEAT

The seat can be adjusted forward or backward to the position that is the most comfortable for you. **Before adjusting the seat, dismount the exercise cycle; do not adjust the seat**

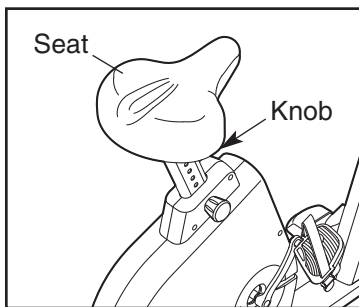

while you are sitting on it. To adjust the seat, turn the seat knob counterclockwise two or three turns to loosen it, slide the seat to the desired position, and then firmly retighten the knob.

CONSOLE DIAGRAM

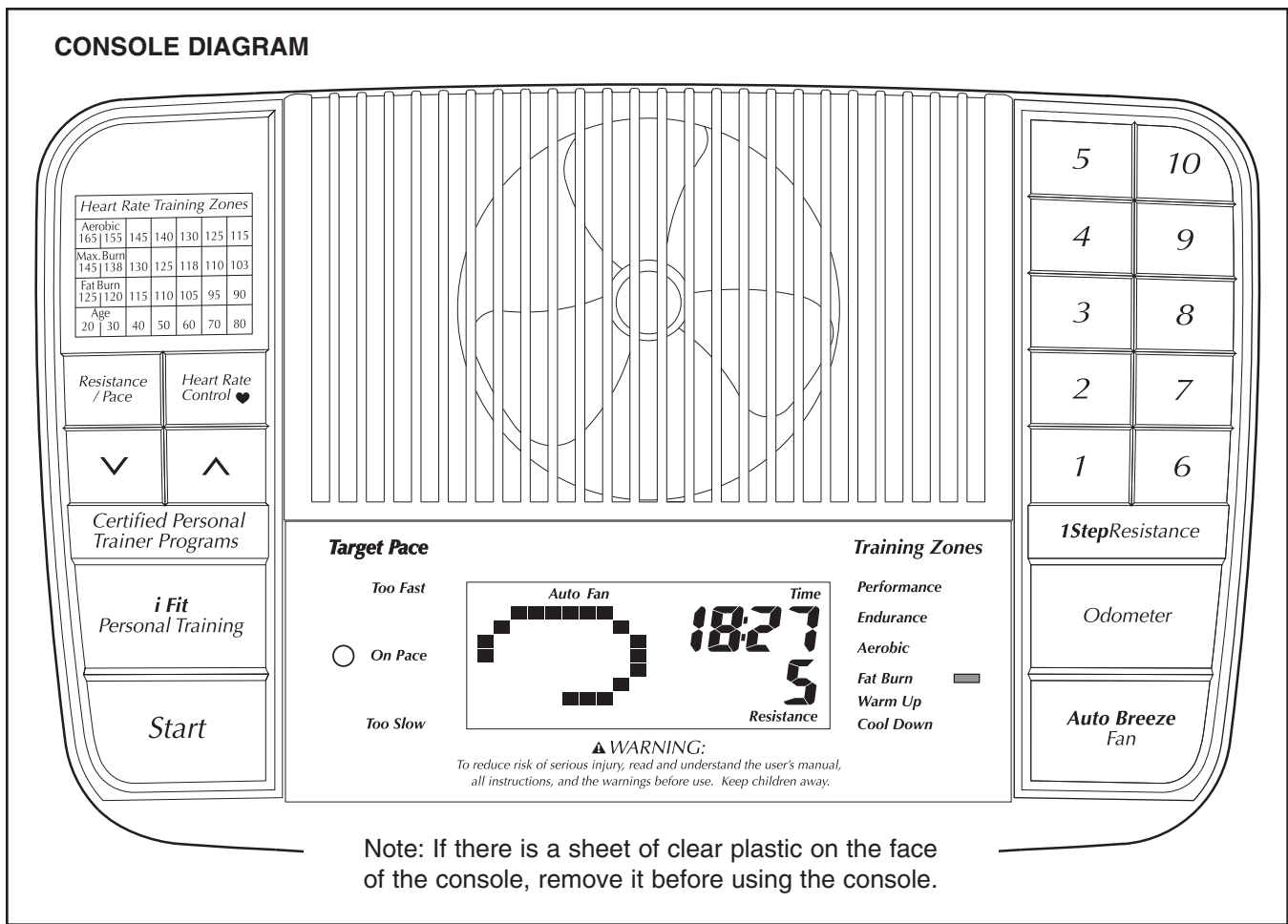

FEATURES OF THE CONSOLE

The advanced console offers a selection of features designed to make your workouts more enjoyable and effective. When the manual mode of the console is selected, the resistance of the pedals can be changed with the touch of a button. As you exercise, the console will provide continuous exercise feedback. You can even measure your heart rate using the handgrip pulse sensor.

The console also offers six preset programs. Each program automatically changes the resistance of the pedals and prompts you to increase or decrease your pace as it guides you through an effective workout.

In addition, the console features two heart rate programs that automatically change the resistance of the pedals and prompt you to vary your pace to keep your heart rate near a target heart rate while you exercise.

The console also features iFIT.com interactive technology. Having iFIT.com technology is like having a personal trainer in your home. Using the included stereo

audio cable, you can connect the exercise cycle to your portable stereo, home stereo, computer, or VCR and play special iFIT.com CD and video programs (iFIT.com CDs and videocassettes are available separately). iFIT.com programs automatically control the resistance of the pedals and prompt you to vary your pace as a personal trainer coaches you through every step of your workout. High-energy music provides added motivation. **To purchase iFIT.com CDs and videocassettes, call the toll-free telephone number on the front cover of this manual.**

With the exercise cycle connected to your computer, you can also go to our Web site at www.iFIT.com and access programs directly from the internet. **Explore www.iFIT.com for more information.**

To use the manual mode of the console, follow the steps beginning on page 11. **To use a preset program**, see page 13. **To use a heart rate program**, see page 14. **To use an iFIT.com CD or video program**, see page 18. **To use an iFIT.com program directly from our Web site**, see page 19.

HOW TO USE THE MANUAL MODE

1 Press any button on the console or begin pedaling to turn on the console.

A few seconds after the console is turned on, the displays will light. A tone will then sound and the console will be ready for use.

2 Select the manual mode.

If you have selected a program or the iFIT.com mode, reselect the manual mode by pressing the iFIT button once or twice until a track appears in the matrix but the letters “iFIT” do not appear.

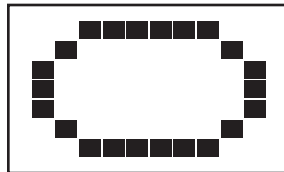

3 Begin pedaling and change the resistance of the pedals as desired.

As you pedal, change the resistance of the pedals by pressing the 1 Step Resistance buttons. Note: After the 1 Step Resistance buttons are pressed, it will take a moment for the exercise cycle to reach the selected resistance level.



4 Monitor your progress with the matrix, the Training Zones bar, and the displays.

The matrix—When the manual mode or the iFIT.com mode is selected, the matrix will show a track representing 1/4 mile.

As you exercise, the indicators around the track will light in succession until the entire track is lit. The track will then darken and the indicators will again begin to light in succession.

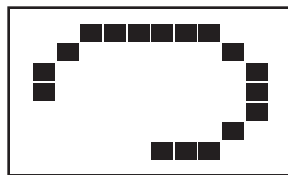

The Training Zones bar—The Training Zones bar will show the approximate intensity level of your exercise.

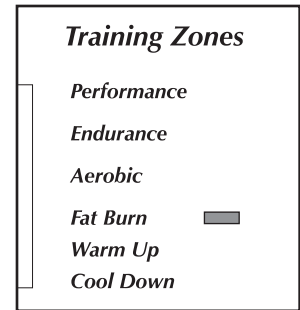

The upper display—The upper display will show the approximate number of grams of carbs you have burned, the approximate number of calories you have burned, the distance you have pedaled, and the elapsed time. The display will change from one number to the next every few seconds. Note: When a program is selected, the display will show the time remaining in the program instead of the elapsed time.

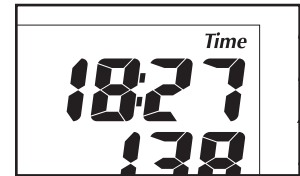

To see the total distance pedaled since the exercise cycle was purchased, press the Odometer button twice; the words “Total Dist.” and the total number of miles will appear in the display. To again see the distance that you have pedaled during your workout, press the Odometer button again.

The lower display—The lower display will show your pedaling pace, in revolutions per minute (RPM), your pedaling speed, and the resistance level of the pedals. The display will change from one number to the next every few seconds. The display will also show your heart rate when you use the handgrip pulse sensor.

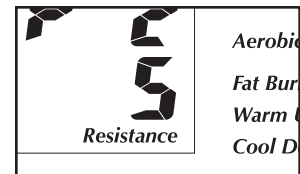

Note: The console can show speed and distance in either miles or kilometers.

The letters MPH or Km/H will appear in the lower display to show which unit of measurement is selected. To change the unit of measurement, first hold down the Start button for a few seconds. An E (for English) or an M (for metric) will appear in the lower display. Press the 1 Step Resistance 10 button to change the unit of measurement. Note: When the batteries are replaced, it may be necessary to reselect the desired unit of measurement.



While you are selecting a unit of measurement, you can also select a backlight mode. The "On" mode keeps the backlight on while the console is on. The "Off" mode turns the backlight off. To conserve the batteries, the "Auto" mode keeps the backlight on only while you are exercising. Press the 1 Step Resistance 1 button to change the backlight mode if desired. Then, press the Start button.



5 Measure your heart rate if desired.

If there are thin sheets of plastic on the metal contacts on the handgrip pulse sensor, peel off the plastic. To measure your heart rate,

hold the handgrip pulse sensor, with your palms resting against the metal contacts. **Avoid moving your hands or gripping the contacts tightly.**

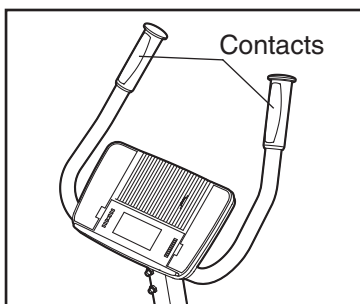

When your pulse is detected, your heart rate will be shown in the lower display. For the most accurate heart rate reading, hold the contacts for at least 15 seconds.

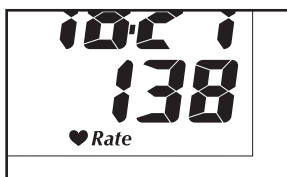

Note: If you continue to hold the handgrip pulse sensor, the lower display will show your heart rate for up to 30 seconds. The display will then show your heart rate along with the other modes.

If your heart rate is not shown, make sure that your hands are positioned as described. Be careful not to move your hands excessively or to squeeze the metal contacts too tightly. For optimal performance, clean the metal contacts using a soft cloth; **never use alcohol, abrasives, or chemicals.**

6 Turn on the fan if desired.

To turn on the fan at low speed, press the Auto Breeze Fan button; the number 1 will appear next to the word "Fan" in the display. To turn on the

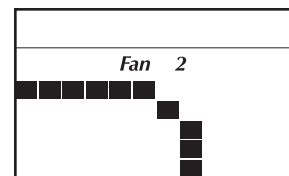

fan at medium speed, press the button a second time; the number 2 will appear. To turn on the fan at high speed, press the button a third time; the number 3 will appear. To select the auto mode, press the button again; the words "Auto Fan" will appear. When the auto mode is selected, the speed of the fan will automatically increase or decrease as you increase or decrease your pedaling speed.

To turn off the fan, press the Auto Breeze Fan button again. Note: If the pedals are not turned for a few minutes, the fan will automatically turn off.

Slide the thumb tab on the right side of the fan to pivot the fan to the desired angle.

7 When you are finished exercising, the console will automatically turn off.

If the pedals are not moved for several seconds, a tone will sound, the console will pause, and the time will begin to flash in the upper display.

If the pedals are not moved for about five minutes, the console will turn off and the displays will be reset.

HOW TO USE A PRESET PROGRAM

1 Press any button on the console or begin pedaling to turn on the console.

See step 1 on page 11.

2 Select one of the six preset programs.

To select one of the six preset programs, press the Resistance/Pace button repeatedly until “P 1,” “P 2,” “P 3,” “P 4,” “P 5,” or “P 6” appears in the upper display.



When a preset program is selected, a profile of the resistance settings of the program will scroll across the matrix and the maximum resistance setting of the program will flash in the lower display. A few seconds after a program is selected, the upper display will show how long the program will last.

3 Press the Start button or begin pedaling to start the program.

Each program is divided into several one-minute segments. One resistance setting and one pace setting are programmed for each segment. Note: The same resistance setting and/or pace setting may be programmed for two or more consecutive segments.

The resistance setting for the first segment will be shown in the flashing Current Segment column of the matrix. (The pace settings are not shown in the matrix.) The resistance settings for the next several segments will be shown in the columns to the right.

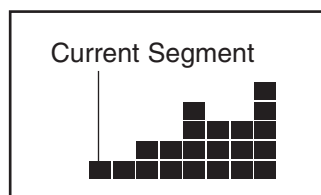

As you exercise, the Target Pace guide will help you to keep your pedaling pace near the pace setting for the current segment. When one of the “Too Slow” indicators lights, increase your pace.

When the one of the “Too Fast” indicators lights, decrease your pace. When the “On Pace” indicator lights, maintain your current pace.

Target Pace	Target Pace	Target Pace
Too Fast	Too Fast	Too Fast
○ On Pace	○ On Pace	● On Pace
▲ Too Slow	Too Slow	Too Slow

Important: The pace settings are intended only to provide motivation. Your actual pace may be slower than the pace settings. Make sure to exercise at a pace that is comfortable for you.

When only three seconds remain in the first segment of the program, both the Current Segment column and the column to the right will flash, a series of tones will sound, and *all resistance settings will move one column to the left*. The resistance setting for the second segment will then be shown in the flashing Current Segment column, and the resistance of the pedals will change to the resistance setting for the second segment. Note: If all of the indicators in the Current Segment column are lit after the resistance settings have moved to the left, *the resistance settings may move downward* so only the highest indicators appear in the matrix.

The program will continue until the resistance setting for the last segment is shown in the Current Segment column and the last segment ends.

Note: During the program, you can override the resistance setting for the current segment, if desired, by pressing the 1 Step Resistance buttons. However, when the next segment begins, the resistance will change if a different resistance setting is programmed for the next segment.

If you stop pedaling for several seconds, a tone will sound and the program will pause. To restart the program, simply resume pedaling.

4 Monitor your progress with the displays.

See step 4 on page 11.

5 Measure your heart rate if desired.

See step 5 on page 12.

6 Turn on the fan if desired.

See step 6 on page 12.

7 When you are finished exercising, the console will automatically turn off.

See step 7 on page 12.

HOW TO USE A HEART RATE PROGRAM

1 Press any button on the console or begin pedaling to turn on the console.

See step 1 on page 11.

2 Select one of the two heart rate programs.

To select a heart rate program, press the Heart Rate Control button once or twice until “P 7” or “P 8” appears in the upper display. A few seconds after a program is selected, the upper display will show how long the program will last.

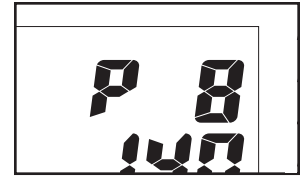

If the first heart rate program (P 7) is selected, a profile of the target heart rate settings of the program will scroll across the matrix.

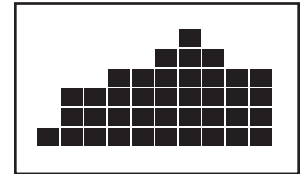

If the second heart rate program (P 8) is selected, a pulse symbol will appear in the matrix.

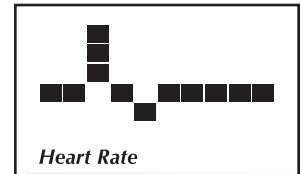

3 Enter a target heart rate setting.

If the first heart rate program is selected, the maximum target heart rate setting of the program will flash in the lower display. If desired, press the

increase and decrease buttons to change the maximum target heart rate setting (see EXERCISE INTENSITY on page 21). Note: If the maximum target heart rate setting is changed, the intensity level of the entire program will change.

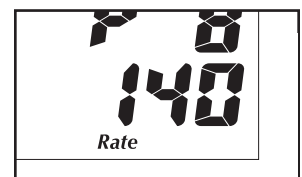

If the second heart rate program is selected, the target heart rate setting for the program will flash in the lower display. If desired, press the increase and decrease buttons to change the target heart rate setting (see EXERCISE INTENSITY on page 21). Note: The same target heart rate setting will be programmed for all segments.

4 Hold the handgrip pulse sensor.

It is not necessary to hold the handgrip pulse sensor continuously during a heart rate program; however, you should hold the handgrip pulse sensor frequently for the program to operate properly. **Each time you hold the handgrip pulse sensor, keep your hands on the metal contacts for at least 30 seconds.**

5 Press the Start button to start the program.

First heart rate program—This program is divided into 20 one-minute segments. One target heart rate setting is programmed for each segment. Note: The same target heart rate setting may be programmed for two or more consecutive segments.

The target heart rate setting for the first segment will be shown in the flashing Current Segment column of the matrix. The target heart rate settings for the next several segments will be shown in the columns to the right.

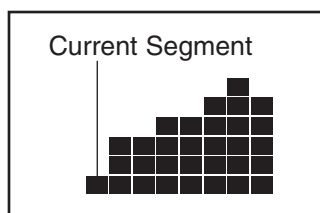

When only three seconds remain in the first segment of the program, both the Current Segment column and the column to the right will flash, a series of tones will sound, and *all target heart rate settings will move one column to the left*. The target heart rate setting for the second segment will then be shown in the flashing Current Segment column.

Second heart rate program—This program is divided into 40 one-minute segments. The same target heart rate is programmed for all segments. Note: For a shorter workout, stop exercising or select a different program before the program ends.

Both heart rate programs—As you pedal, the console will regularly compare your heart rate to the target heart rate setting. If your heart rate is too far below or above the target heart rate setting, the resistance of the pedals will automatically increase or decrease to bring your heart rate closer to the target heart rate setting.

The Target Pace guide will prompt you to increase or decrease your pedaling pace during the program. When one of the “Too Slow” indicators lights, increase your pace. When the one of the “Too Fast” indicators lights, decrease your pace. When the “On Pace” indicator lights, maintain your current pace.

Target Pace	Target Pace	Target Pace
<i>Too Fast</i>	<i>Too Fast</i>	<i>Too Fast</i>
○ <i>On Pace</i>	○ <i>On Pace</i>	● <i>On Pace</i>
▲ <i>Too Slow</i>	<i>Too Slow</i>	<i>Too Slow</i>

Important: The target heart rate settings are intended only to provide motivation. Your actual heart rate may be slower than the target heart rate settings. Make sure to exercise at a pace that is comfortable for you.

Note: During the program, you can manually override the resistance setting for the current segment, if desired, with the 1 Step Resistance buttons. However, when the console compares your heart rate to the target heart rate setting, the resistance of the pedals may automatically increase or decrease to bring your heart rate closer to the target heart rate setting.

If you stop pedaling for several seconds, a tone will sound and the program will pause. To restart the program, simply resume pedaling.

6 Monitor your progress with the displays.

See step 4 on page 11.

7 Turn on the fan if desired.

See step 6 on page 12.

8 When you are finished exercising, the console will automatically turn off.

See step 7 on page 12.

HOW TO CONNECT YOUR CD PLAYER, VCR, OR COMPUTER

To use **iFIT.com CDs**, the exercise cycle must be connected to your portable CD player, portable stereo, home stereo, or computer with CD player. See pages 16 and 17 for connecting instructions. To use **iFIT.com videocassettes**, the exercise cycle must be connected to your VCR. See page 18 for connecting instructions. To use **iFIT.com programs directly from our Web site**, the exercise cycle must be connected to your home computer. See page 17 for connecting instructions.

HOW TO CONNECT YOUR PORTABLE CD PLAYER

Note: If your CD player has separate **LINE OUT** and **PHONES** jacks, see instruction A below. If your CD player has only one jack, see instruction B.

- A. Plug one end of the audio cable into the jack beneath the console. Plug the other end of the cable into the **LINE OUT** jack on your CD player. Plug your headphones into the **PHONES** jack.

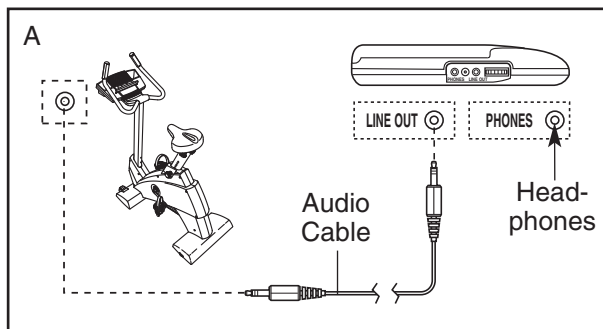

- B. Plug one end of the audio cable into the jack beneath the console. Plug the other end of the cable into a 1/8" Y-adapter (available at electronics stores). Plug the Y-adapter into the **PHONES** jack on your CD player. Plug your headphones into the other side of the Y-adapter.

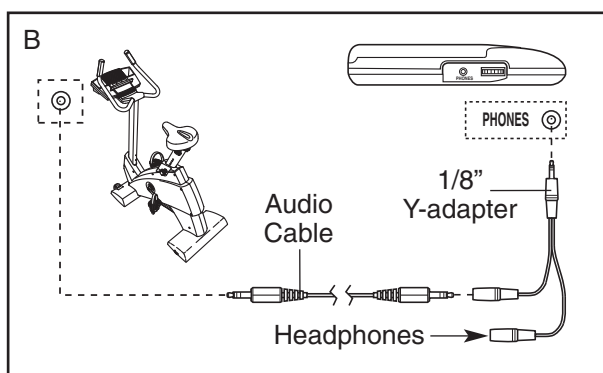

HOW TO CONNECT YOUR PORTABLE STEREO

Note: If your stereo has an **RCA-type AUDIO OUT** jack, see instruction A below. If your stereo has a 1/8" **LINE OUT** jack, see instruction B. If your stereo has only a **PHONES** jack, see instruction C.

- A. Plug one end of the audio cable into the jack beneath the console. Plug the other end of the cable into the adapter. Plug the adapter into an **AUDIO OUT** jack on your stereo.

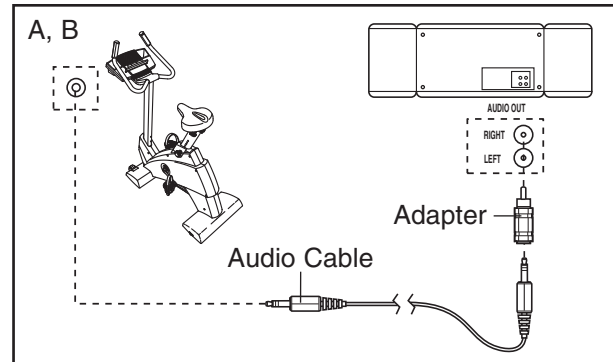

- B. Plug one end of the audio cable into the jack beneath the console. Plug the other end of the cable into the **LINE OUT** jack on your stereo. Do not use the adapter.

- C. Plug one end of the audio cable into the jack beneath the console. Plug the other end of the cable into a 1/8" Y-adapter (available at electronics stores). Plug the Y-adapter into the **PHONES** jack on your stereo. Plug your headphones into the other side of the Y-adapter.

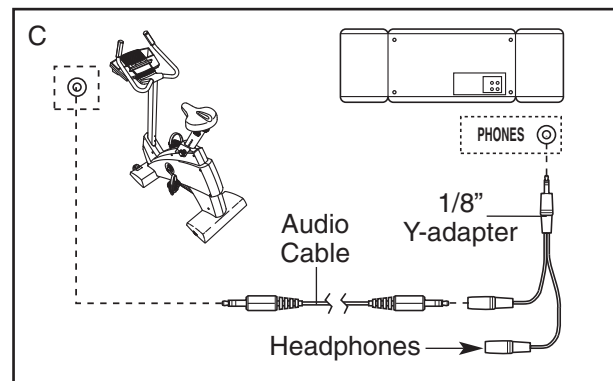

HOW TO CONNECT YOUR HOME STEREO

Note: If your stereo has an unused **LINE OUT** jack, see instruction **A** below. If the **LINE OUT** jack is being used, see instruction **B**.

- A. Plug one end of the audio cable into the jack beneath the console. Plug the other end of the cable into the adapter. Plug the adapter into the **LINE OUT** jack on your stereo.

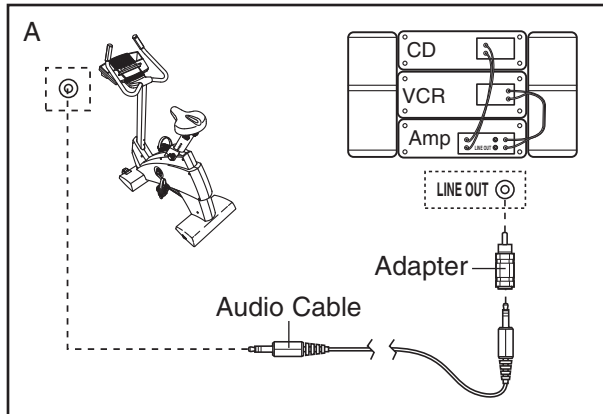

- B. Plug one end of the audio cable into the jack beneath the console. Plug the other end of the cable into the adapter. Plug the adapter into an **RCA Y-adapter** (available at electronics stores). Next, remove the wire that is currently plugged into the **LINE OUT** jack on your stereo and plug the wire into the unused side of the Y-adapter. Plug the Y-adapter into the **LINE OUT** jack on your stereo.

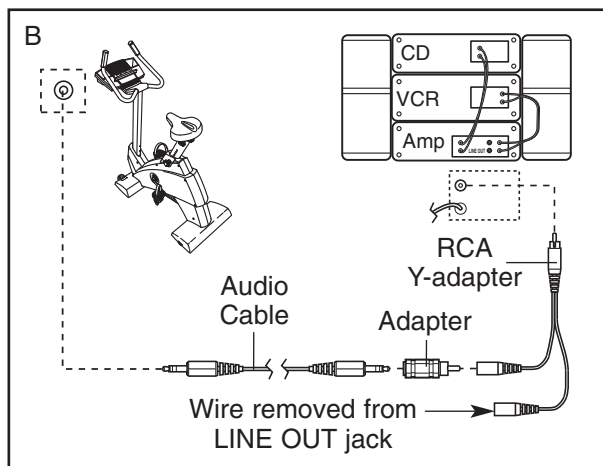

HOW TO CONNECT YOUR COMPUTER

Note: If your computer has a **1/8" LINE OUT** jack, see instruction **A**. If your computer has only a **PHONES** jack, see instruction **B**.

- A. Plug one end of the audio cable into the jack beneath the console. Plug the other end of the cable into the **LINE OUT** jack on your computer.

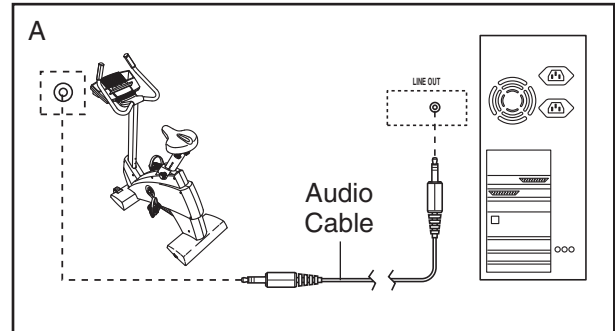

- B. Plug one end of the audio cable into the jack beneath the console. Plug the other end of the cable into a **1/8" Y-adapter** (available at electronics stores). Plug the Y-adapter into the **PHONES** jack on your computer. Plug your headphones or speakers into the other side of the Y-adapter.

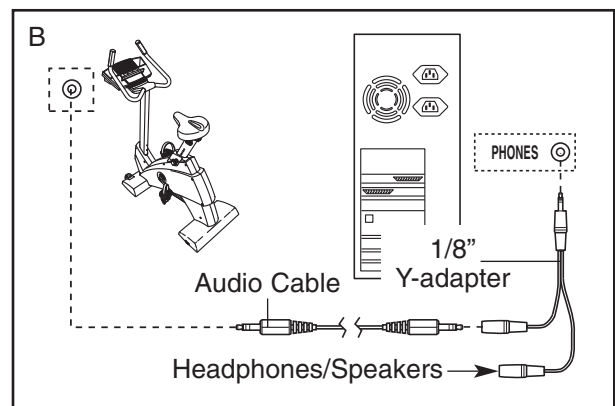

HOW TO CONNECT YOUR VCR

Note: If your VCR has an unused AUDIO OUT jack, see instruction A below. If the AUDIO OUT jack is being used, see instruction B. If you have a TV with a built-in VCR, see instruction B. If your VCR is connected to your home stereo, see **HOW TO CONNECT YOUR HOME STEREO** on page 17.

- A. Plug one end of the audio cable into the jack beneath the console. Plug the other end of the cable into the adapter. Plug the adapter into the AUDIO OUT jack on your VCR.

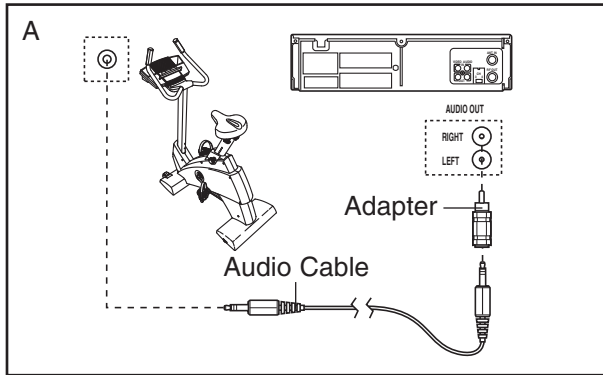

- B. Plug one end of the audio cable into the jack beneath the console. Plug the other end of the cable into the adapter. Plug the adapter into an RCA Y-adapter (available at electronics stores). Next, remove the wire that is currently plugged into the AUDIO OUT jack on your VCR and plug the wire into the unused side of the Y-adapter. Plug the Y-adapter into the AUDIO OUT jack on your VCR.

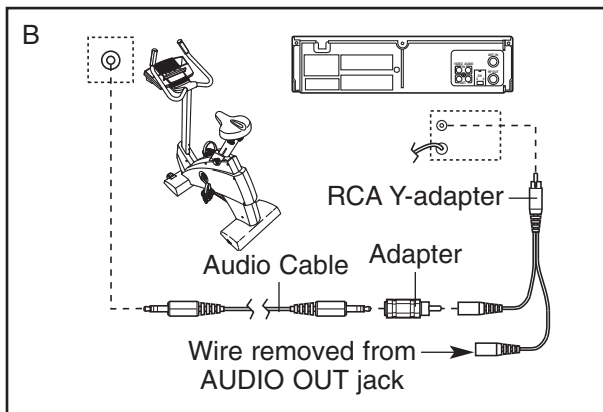

HOW TO USE AN iFIT.COM CD OR VIDEO PROGRAM

To use an iFIT.com CD or video program, the exercise cycle must be connected to your CD player or VCR. See **HOW TO CONNECT YOUR CD PLAYER, VCR, OR COMPUTER** on pages 16 to 18. **To purchase iFIT.com CDs or videocassettes, call the toll-free telephone number on the front cover of this manual.**

Follow the steps below to use an iFIT.com CD or video program.

- 1** Press any button on the console or begin pedaling to turn on the console.

See step 1 on page 11.

- 2** Select the iFIT.com mode.

To select the iFIT.com mode, press the iFIT button. The track and the letters "iFIT" will appear.

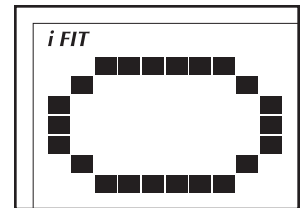

- 3** Press the Play button on your CD player or VCR.

Note: If you are using an iFIT.com CD, insert the CD into your CD player; if you are using an iFIT.com videocassette, insert the videocassette into your VCR.

A moment after the play button is pressed, your personal trainer will begin guiding you through your workout. Simply follow your personal trainer's instructions.

The program will function in almost the same way as a preset program (see step 3 on page 13). However, an electronic "chirping" sound will alert you when the resistance setting and/or pace setting is about to change.

Note: If the resistance of the pedals and/or the pace setting does not change when a “chirp” is heard:

- Make sure that the letters “iFIT” appear in the display.
- Adjust the volume of your CD player or VCR. If the volume is too high or too low, the console may not detect the program signals.
- Make sure that the audio cable is properly connected and that it is fully plugged in.

4 Monitor your progress with the displays.

See step 4 on page 11.

5 Measure your heart rate as desired.

See step 5 on page 12.

6 Turn on the fan if desired.

See step 6 on page 12.

7 When you are finished exercising, the console will automatically turn off.

See step 7 on page 12.

HOW TO USE AN iFIT.COM PROGRAM DIRECTLY FROM OUR WEB SITE

Our Web site at www.iFIT.com allows you to play iFIT.com programs directly from the internet. To use programs from our Web site, the exercise cycle must be connected to your home computer. See HOW TO CONNECT YOUR COMPUTER on page 17. In addition, you must have an internet connection and an internet service provider. A list of specific system requirements is found on our Web site.

Follow the steps below to use a program from our Web site.

1 Press any button on the console or begin pedaling to turn on the console.

See step 1 on page 11.

2 Select the iFIT.com mode.

See step 2 on page 18.

3 Go to your computer and start an internet connection.

4 Start your Web browser, if necessary, and go to our Web site at www.iFIT.com.

5 Follow the desired links on our Web site to select a program.

Read and follow the on-line instructions for using a program.

6 Follow the on-line instructions to start the program.

When you start the program, an on-screen countdown will begin.

7 Return to the exercise cycle and begin pedaling.

When the on-screen countdown ends, the program will begin. The program will function in almost the same way as a preset program (see step 3 on page 13). However, an electronic “chirping” sound will alert you when the resistance setting and/or pace setting is about to change.

8 Monitor your progress with the displays.

See step 4 on page 11.

9 Measure your heart rate if desired.

See step 5 on page 12.

10 Turn on the fan if desired.

See step 6 on page 12.

11 When you are finished exercising, the console will automatically turn off.

See step 7 on page 12.

MAINTENANCE AND TROUBLESHOOTING

Inspect and tighten all parts of the exercise cycle regularly. Replace any worn parts immediately.

To clean the exercise cycle, use a damp cloth and a small amount of mild soap. **Important: To avoid damage to the console, keep liquids away from the console and keep the console out of direct sunlight.**

BATTERY REPLACEMENT

If the console display becomes dim, the batteries should be replaced; most console problems are the result of low batteries. See assembly step 7 on page 8 for replacement instructions.

HOW TO LEVEL THE EXERCISE CYCLE

After the exercise cycle has been moved to the location where it will be used, make sure that both ends of the front stabilizer are touching the floor. If the exercise cycle rocks slightly during use, turn one or both of the leveling feet under the front stabilizer until the rocking motion is eliminated.

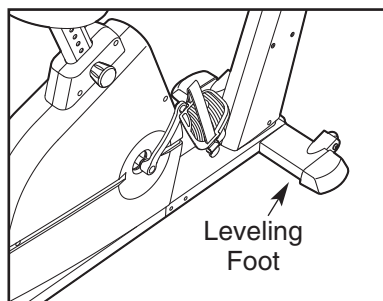

HANDGRIP PULSE SENSOR TROUBLESHOOTING

If the handgrip pulse sensor does not function properly, see step 5 on page 12.

HOW TO MOVE THE EXERCISE CYCLE

To move the exercise cycle, hold the handle on the rear stabilizer and carefully lift it until the exercise cycle can be moved on the front wheels. Carefully move the exercise cycle to the desired location and then lower it.

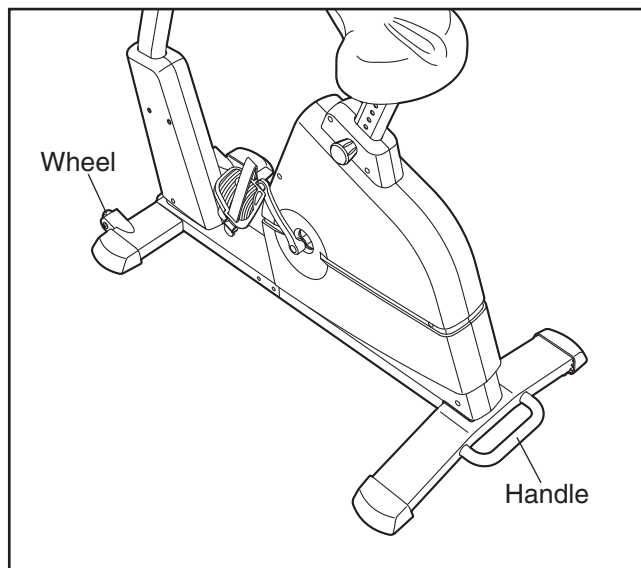

CONDITIONING GUIDELINES

The following guidelines will help you to plan your exercise program. Remember that proper nutrition and adequate rest are essential for successful results.

⚠ WARNING: Before beginning this or any exercise program, consult your physician. This is especially important for persons over the age of 35 or persons with pre-existing health problems.

The pulse sensor is not a medical device. Various factors may affect the accuracy of heart rate readings. The pulse sensor is intended only as an exercise aid in determining heart rate trends in general.

EXERCISE INTENSITY

Whether your goal is to burn fat or to strengthen your cardiovascular system, the key to achieving the desired results is to exercise with the proper intensity. The proper intensity level can be found by using your heart rate as a guide. The chart below shows recommended heart rates for fat burning, maximum fat burning, and cardiovascular (aerobic) exercise.

165	155	145	140	130	125	115	♥
145	138	130	125	118	110	103	♥
125	120	115	110	105	95	90	♥
<hr/>							
20	30	40	50	60	70	80	

To find the proper heart rate for you, first find your age at the bottom of the chart (ages are rounded off to the nearest ten years). Next, find the three numbers above your age. The three numbers are your “training zone.” The lowest number is the recommended heart rate for fat burning; the middle number is the recommended heart rate for maximum fat burning; the highest number is the recommended heart rate for aerobic exercise.

Fat Burning

To burn fat effectively, you must exercise at a relatively low intensity level for a sustained period of time.

During the first few minutes of exercise, your body uses easily accessible *carbohydrate* calories for energy. Only after the first few minutes of exercise does your body begin to use stored *fat* calories for energy. If your goal is to burn fat, adjust the intensity of your exercise until your heart rate is near the lowest number in your training zone as you exercise. For maximum fat burning, adjust the intensity of your exercise until your heart rate is near the middle number in your training zone as you exercise.

Aerobic Exercise

If your goal is to strengthen your cardiovascular system, your exercise must be “aerobic.” Aerobic exercise is activity that requires large amounts of oxygen for prolonged periods of time. This increases the demand on the heart to pump blood to the muscles, and on the lungs to oxygenate the blood. For aerobic exercise, adjust the intensity of your exercise until your heart rate is near the highest number in your training zone.

WORKOUT GUIDELINES

Each workout should include the following three parts:

A warm-up, consisting of 5 to 10 minutes of stretching and light exercise. A proper warm-up increases your body temperature, heart rate, and circulation in preparation for exercise.

Training zone exercise, consisting of 20 to 30 minutes of exercising with your heart rate in your training zone. Note: During the first few weeks of your exercise program, do not keep your heart rate in your training zone for longer than 20 minutes.

A cool-down, with 5 to 10 minutes of stretching. This will increase the flexibility of your muscles and will help to prevent post-exercise problems.

EXERCISE FREQUENCY

To maintain or improve your condition, plan three workouts each week, with at least one day of rest between workouts. After a few months of regular exercise, you may complete up to five workouts each week, if desired. Remember, the key to success is make exercise a regular and enjoyable part of your everyday life.

PART LIST—Model No. 30506.0

R0605A

Key No.	Qty.	Description	Key No.	Qty.	Description
1	1	Frame	43	1	Lower Wire Harness
2	1	Upright	44	1	Flywheel Spacer
3	1	Handlebar	45	1	Clamp
4	1	Console	46	1	Reed Switch/Wire
5	1	Upright Frame	47	1	Drive Belt
6	2	Pulse Sensor	48	2	Rear Stabilizer Endcap
7	1	Frame Bushing	49	1	M8 x 52mm Button Bolt
8	1	Seat Post	50	2	Flange Screw
9	1	Seat	51	1	Middle Wire Harness
10	1	Seat Knob	52	4	M8 x 54mm Button Screw
11	1	Seat Carriage	53	1	Pillow Block
12	1	Seat Bushing	54	6	M8 x 22mm Button Screw
13	1	Left Front Side Shield	55	14	M8 Split Washer
14	1	Right Front Side Shield	56	4	M10 x 54mm Button Screw
15	1	Left Front Stabilizer	57	26	M4 x 16mm Screw
16	1	Rear Stabilizer	58	4	M6 x 13mm Button Screw
17	2	Wheel	59	2	M6 x 8mm Button Screw
18	1	Right Pedal Strap	60	2	M4 x 22mm Screw
19	2	Leveling Foot	61	1	Small Snap Ring
20	1	Seat Post Knob	62	4	6.35mm Spacer
21	1	Right Pedal	63	4	Wheel Bushing
22	1	Left Pedal	64	2	M6 Nut
23	1	Right Crank Arm	65	2	M10 Nylon Locknut
24	1	Left Crank Arm	66	2	Front Stabilizer Endcap
25	1	Left Pedal Strap	67	1	Flange Nut
26	1	Left Side Shield	68	1	M8 x 40mm Bolt
27	1	Right Side Shield	69	2	Wheel Bolt
28	1	Snap Ring	70	1	M6 x 38mm Bolt
29	1	Pulley	71	8	M10 Split Washer
30	1	Magnet	72	4	M6 Nylon Locknut
31	1	Crank Assembly	73	4	M6 x 20mm Button Bolt
32	1	Steel Washer	74	1	Water Bottle Holder
33	2	Crank Bearing	75	1	Pulse Wire
34	1	Flywheel	76	4	Curved Spacer
35	1	"C" Magnet	77	4	M10 x 97mm Button Screw
36	1	Resistance Cable	78	1	Spring Bolt
37	1	Spring	79	8	M8 Nylon Locknut
38	1	Resistance Motor	80	4	M4 x 16mm Round Head Screw
39	1	Idler Arm	81	4	M4 Washer
40	1	Right Front Stabilizer	#	1	Allen Wrench
41	1	Upright Frame Endcap	#	1	User's Manual
42	1	Upper Wire Harness			

Note: “#” indicates a non-illustrated part. Specifications are subject to change without notice. See the back cover of this manual for information about ordering replacement parts.

EXPLODED DRAWING—Model No. 30506.0

R0605A

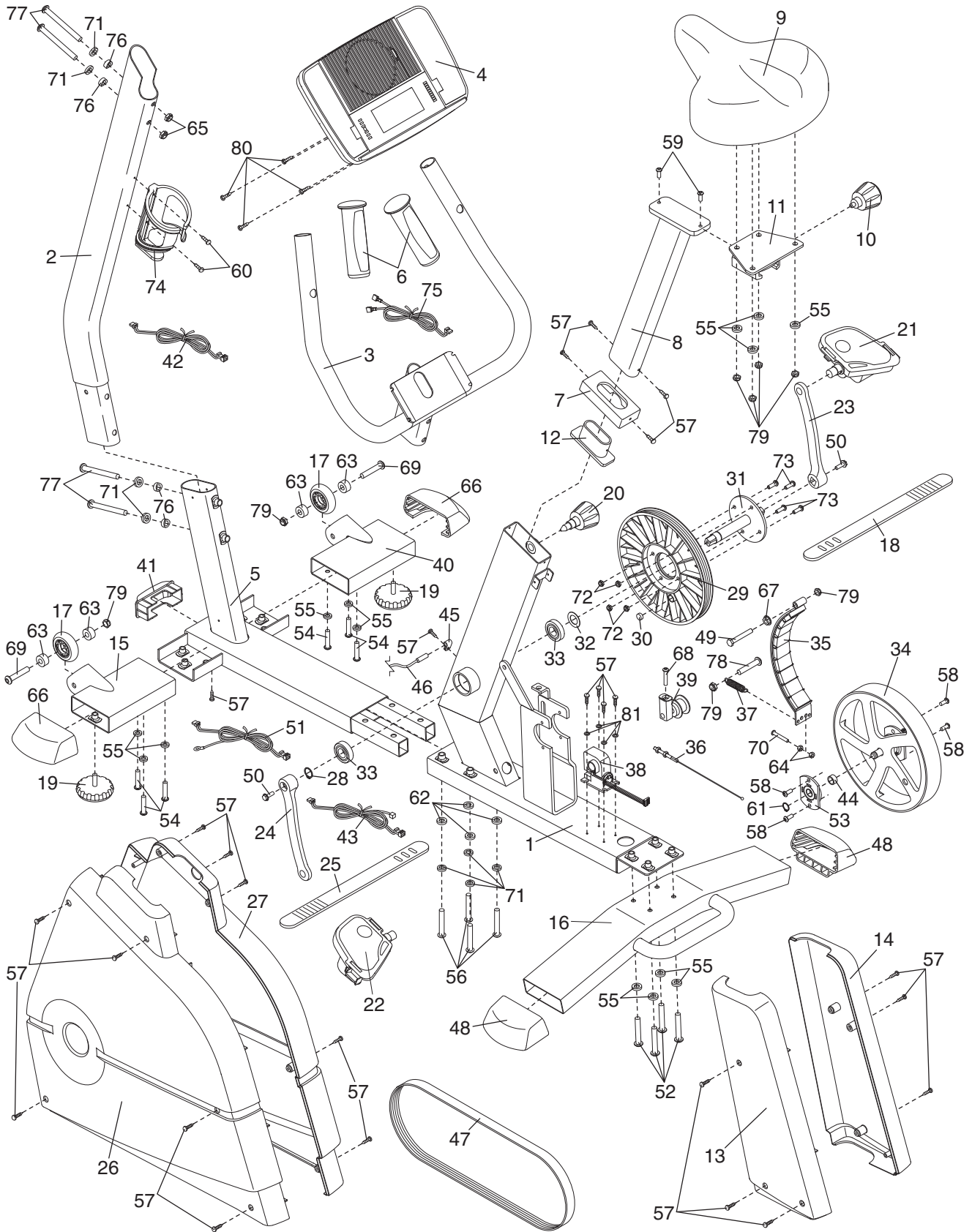

HOW TO ORDER REPLACEMENT PARTS

To order replacement parts, call the toll-free telephone number on the front cover of this manual. To help us assist you, please be prepared to give the following information:

- the MODEL NUMBER of the product (30506.0)
- the NAME of the product (NordicTrack SL 528 exercise cycle)
- the SERIAL NUMBER of the product (see the front cover of this manual)
- the KEY NUMBER and DESCRIPTION of the part(s) (see the PART LIST on page 22)

LIMITED WARRANTY

ICON OF CANADA, INC., (ICON), warrants this product to be free from defects in workmanship and material, under normal use and service conditions, for a period of one (1) year from the date of purchase. This warranty extends only to the original purchaser. ICON's obligation under this warranty is limited to replacing or repairing, at ICON's option, the product through one of its authorized service centers. All repairs for which warranty claims are made must be pre-authorized by ICON. This warranty does not extend to any product or damage to a product caused by or attributable to freight damage, abuse, misuse, improper or abnormal usage or repairs not provided by an ICON authorized service center, to products used for commercial or rental purposes, or to products used as store display models. No other warranty beyond that specifically set forth above is authorized by ICON.

ICON is not responsible or liable for indirect, special or consequential damages arising out of or in connection with the use or performance of the product or damages with respect to any economic loss, loss of property, loss of revenues or profits, loss of enjoyment or use, costs of removal, installation or other consequential damages of whatsoever nature. Some provinces do not allow the exclusion or limitation of incidental or consequential damages. Accordingly, the above limitation may not apply to you. The warranty extended hereunder is in lieu of any and all other warranties and any implied warranties of merchantability or fitness for a particular purpose is limited in its scope and duration to the terms set forth herein. Some provinces do not allow limitations on how long an implied warranty lasts. Accordingly, the above limitation may not apply to you.

This warranty gives you specific legal rights. You may also have other rights which vary from province to province or so specified by the retailer of your equipment.

ICON OF CANADA, INC., 900 de l'Industrie, St. Jérôme, QC J7Y 4B8