

# PRO-FORM<sup>®</sup>

## XP 210 U

Model No. 831.21941.2

Serial No. \_\_\_\_\_

Write the serial number in the space above for reference.

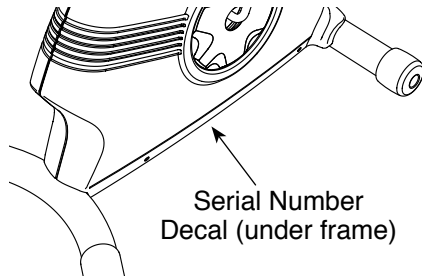

- Assembly
- Operation
- Maintenance
- Part List and Drawing

Sears, Roebuck and Co.  
Hoffman Estates, IL 60179

### CAUTION

Read all precautions and instructions in this manual before using this equipment. Keep this manual for future reference.

## BIKE EXERCISER User's Manual

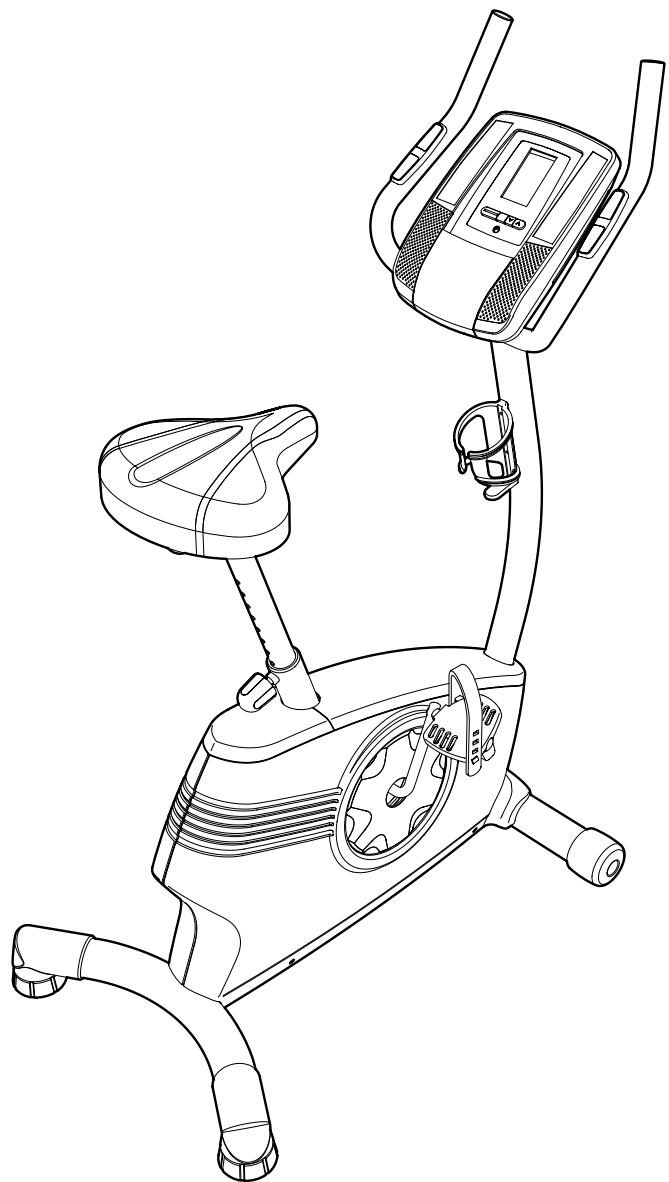

# TABLE OF CONTENTS

WARNING DECAL PLACEMENT .....	2
IMPORTANT PRECAUTIONS .....	3
BEFORE YOU BEGIN .....	4
PART IDENTIFICATION CHART .....	5
ASSEMBLY .....	6
HOW TO USE THE EXERCISE BIKE .....	12
FCC INFORMATION .....	18
MAINTENANCE AND TROUBLESHOOTING .....	19
EXERCISE GUIDELINES .....	21
PART LIST .....	22
EXPLODED DRAWING .....	23
ORDERING REPLACEMENT PARTS .....	Back Cover
90 DAY FULL WARRANTY .....	Back Cover

## WARNING DECAL PLACEMENT

This drawing shows the location(s) of the warning decal(s). **If a decal is missing or illegible, call 1-888-533-1333 and request a free replacement decal. Apply the decal in the location shown.**  
Note: The decal(s) may not be shown at actual size.

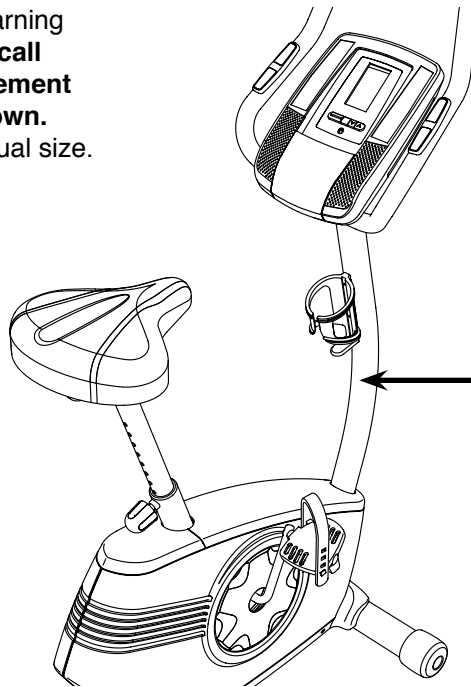

**⚠ WARNING**

- Misuse of this machine may result in serious injury.
- Read user's manual prior to use and follow all warnings and instructions.
- Do not allow children on or around machine.
- Pedals continue to spin when you stop pedaling.
- Spinning pedals can cause injury.
- Reduce pedal speed in a controlled manner.
- User weight must not exceed 250 pounds.
- Replace label if damaged, illegible, or removed.

---

# IMPORTANT PRECAUTIONS

**⚠️ WARNING:** To reduce the risk of serious injury, read all important precautions and instructions in this manual and all warnings on your exercise bike before using your exercise bike. Sears assumes no responsibility for personal injury or property damage sustained by or through the use of this product.

1. Before beginning any exercise program, consult your physician. This is especially important for persons over age 35 or persons with pre-existing health problems.
2. Use the exercise bike only as described in this manual.
3. It is the responsibility of the owner to ensure that all users of the exercise bike are adequately informed of all precautions.
4. The exercise bike is intended for home use only. Do not use the exercise bike in a commercial, rental, or institutional setting.
5. Keep the exercise bike indoors, away from moisture and dust. Do not put the exercise bike in a garage or covered patio, or near water.
6. Place the exercise bike on a level surface, with a mat beneath it to protect the floor or carpet. Make sure that there is at least 2 ft. (0.6 m) of clearance around the exercise bike.
7. Inspect and properly tighten all parts regularly. Replace any worn parts immediately.
8. Keep children under age 12 and pets away from the exercise bike at all times.
9. Wear appropriate clothes while exercising; do not wear loose clothes that could become caught on the exercise bike. Always wear athletic shoes for foot protection.
10. The heart rate monitor is not a medical device. Various factors may affect the accuracy of heart rate readings. The heart rate monitor is intended only as an exercise aid in general.
11. The exercise bike should not be used by persons weighing more than 250 lbs. (113 kg).
12. Always keep your back straight while using the exercise bike; do not arch your back.
13. The exercise bike does not have a freewheel; the pedals will continue to move until the flywheel stops. Reduce your pedaling speed in a controlled way.
14. Over exercising may result in serious injury or death. If you feel faint or if you experience pain while exercising, stop immediately and cool down.

# BEFORE YOU BEGIN

Thank you for selecting the new PROFORM® XP 210 U exercise bike. Cycling is an effective exercise for increasing cardiovascular fitness, building endurance, and toning the body. The XP 210 U exercise bike provides a selection of features designed to make your workouts at home more effective and enjoyable.

**For your benefit, read this manual carefully before you use the exercise bike.** If you have questions after

reading this manual, please see the back cover of this manual. To help us assist you, note the product model number and serial number before contacting us. The model number and the location of the serial number decal are shown on the front cover of this manual.

Before reading further, please familiarize yourself with the parts that are labeled in the drawing below.

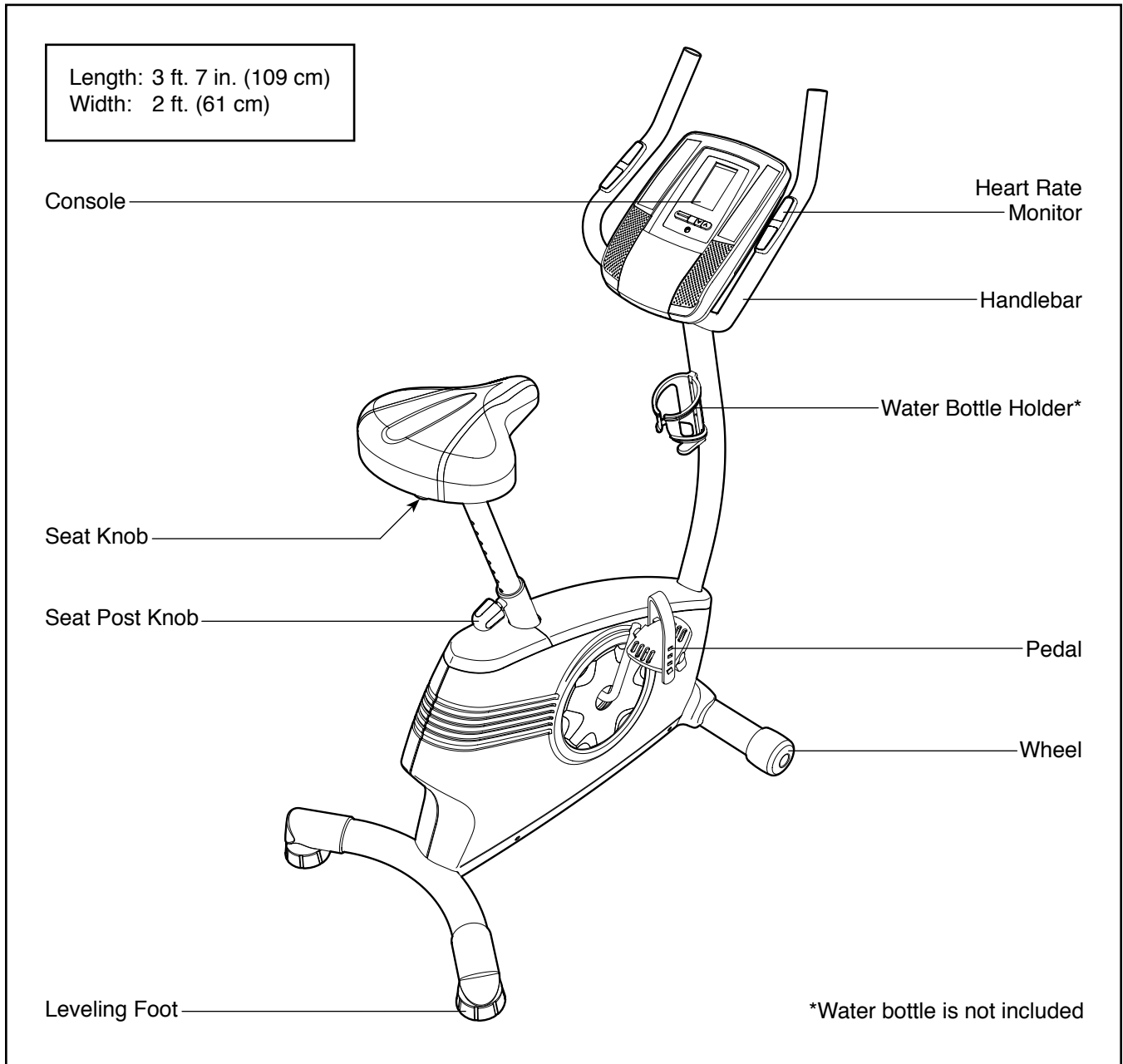

# PART IDENTIFICATION CHART

Use the drawings below to identify the small parts needed for assembly. The number in parentheses below each drawing is the key number of the part, from the PART LIST near the end of this manual. The number following the key number is the quantity needed for assembly. **Note: If a part is not in the hardware kit, check to see if it has been preassembled. Extra parts may be included. If a part is missing, please call 1-888-533-1333.**

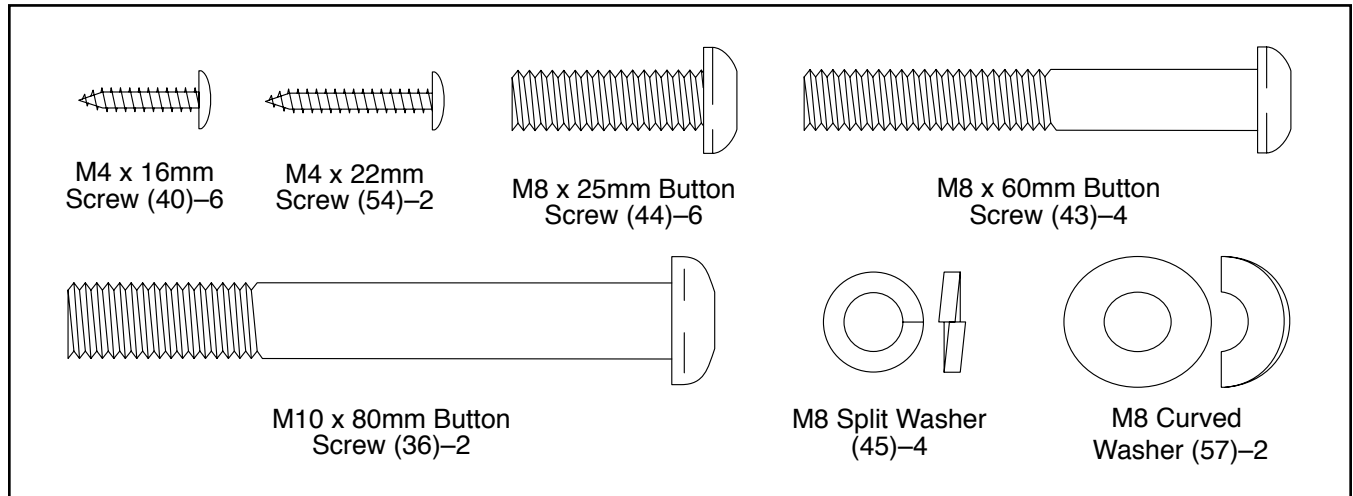

# ASSEMBLY

- Assembly requires two persons.
- Place all parts in a cleared area and remove the packing materials. Do not dispose of the packing materials until you complete all assembly steps.
- To identify small parts, see page 5.

- In addition to the included tool(s), assembly requires the following tools:

one Phillips screwdriver 

one adjustable wrench 

Assembly may be easier if you have your own set of wrenches. To avoid damaging parts, do not use power tools.

1. Orient the Rear Stabilizer (14) as shown.

Tighten the two Leveling Feet (50) into the underside of the Rear Stabilizer (14).

While a second person lifts the rear of the Frame (1), insert the Rear Stabilizer into the Frame.

Attach the Rear Stabilizer (14) with four M8 x 60mm Button Screws (43).

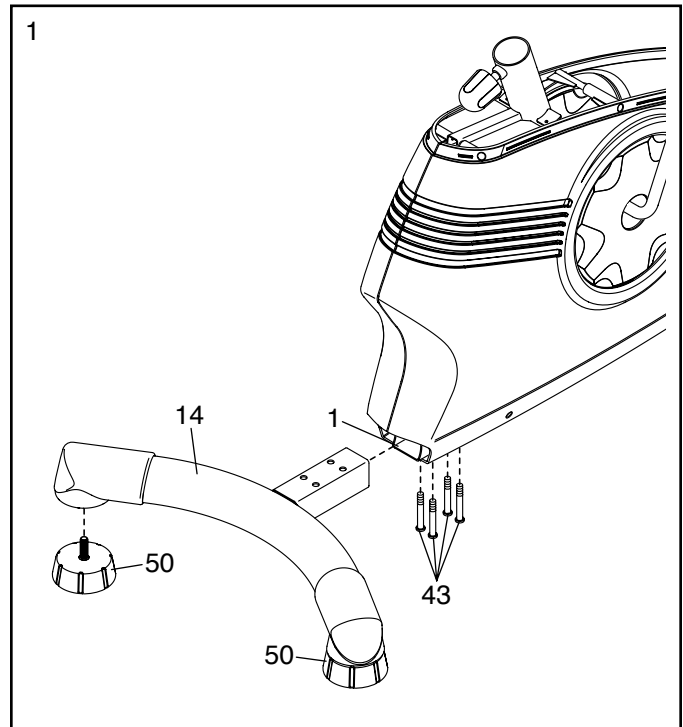

2. Orient the Front Stabilizer (2) as indicated by the sticker.

While a second person lifts the front of the Frame (1), attach the Front Stabilizer (2) to the Frame with two M10 x 80mm Button Screws (36).

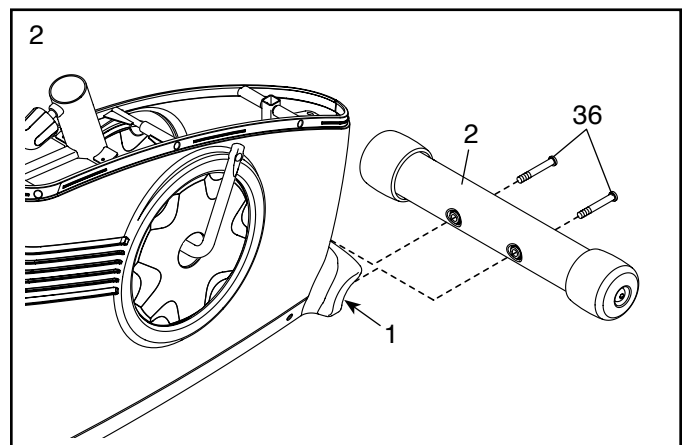

3. Orient the Upright (3) as shown. Have a second person hold the Upright near the Frame (1).

Locate the wire tie in the lower end of the Upright (3). Tie the wire tie to the Main Wire (31). Then, pull the upper end of the wire tie until the Main Wire is routed through the Upright.

**Tip: To prevent the Main Wire (31) from falling into the Upright (3), secure the Main Wire with the wire tie.**

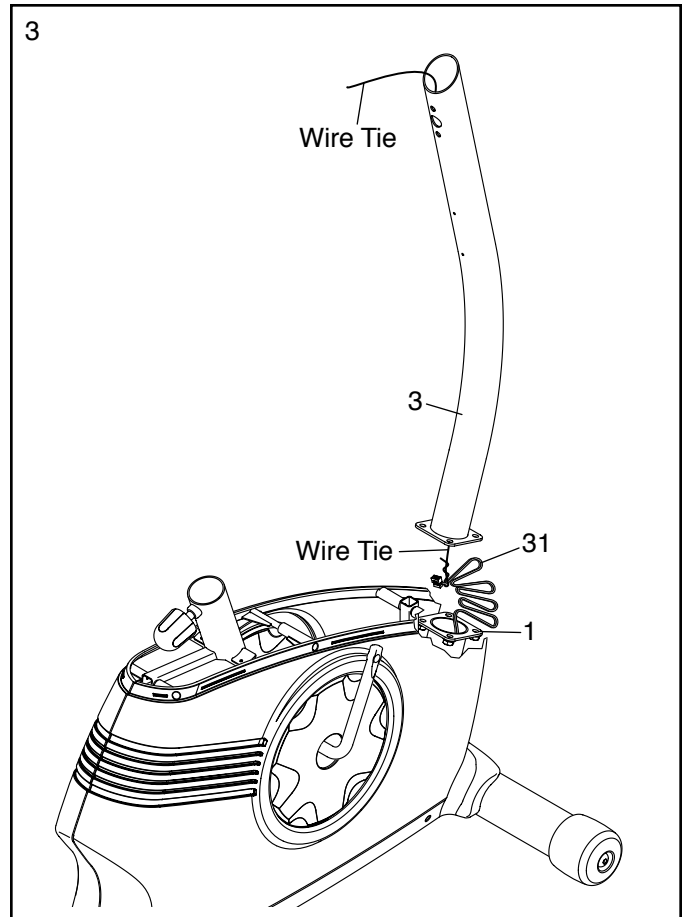

4. **Tip: Avoid pinching the Main Wire (31).** Set the Upright (3) on the Frame (1).

Attach the Upright (3) with four M8 x 25mm Button Screws (44) and four M8 Split Washers (45). **Tip: Start all the Button Screws before fully tightening them.**

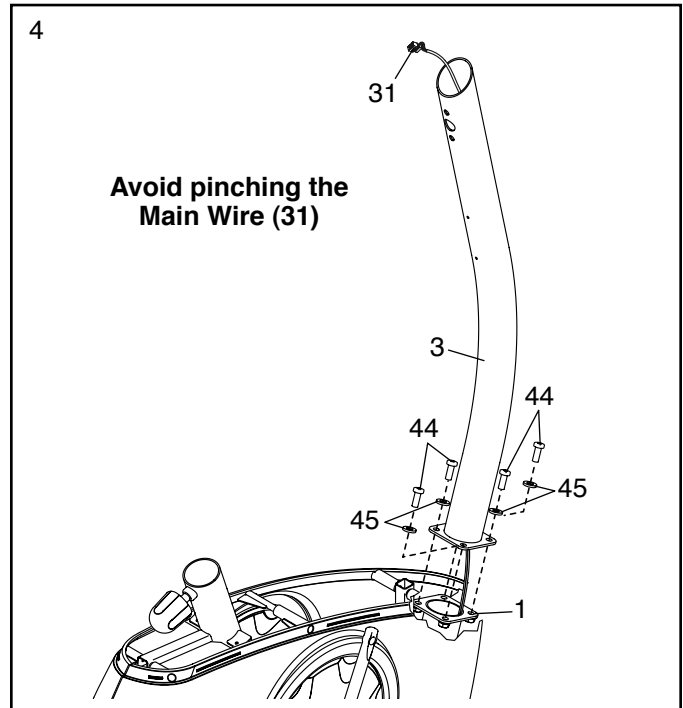

5. Orient the Top Shield (9) as shown. Slide the Top Shield onto the Upright (3).

Attach the Top Shield (9) to the Frame (1) with two M4 x 16mm Screws (40).

Orient the Top Shield Cap (10) as shown. Press the Top Shield Cap onto the Left and Right Shields (17, 18).

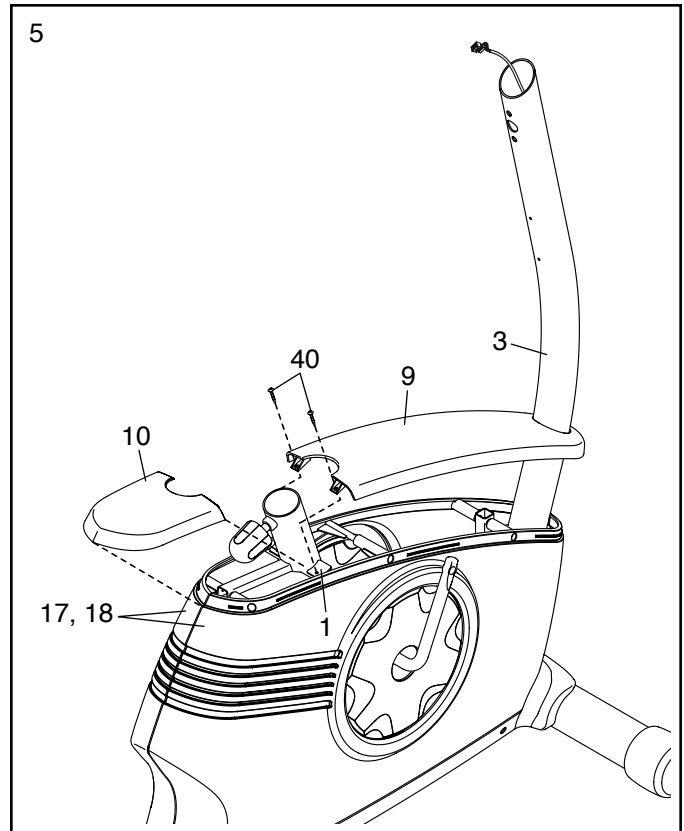

6. Orient the Seat (12) and the Seat Carriage (30) as shown. Attach the Seat to the Seat Carriage with four M8 Locknuts (37), four M8 Split Washers (45), and four M8 Washers (56).

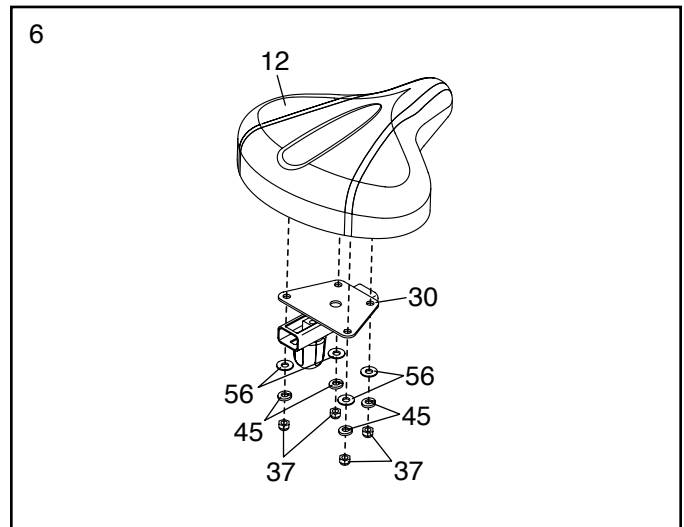



7. Loosen and remove the Seat Knob (11) from the Seat Carriage (30).

Look underneath the Seat (12), and locate the Carriage Block (55) inside the Seat Carriage (30).

Orient the Seat Post (5) as shown. Set the Seat Carriage (30) in the bracket on the Seat Post.

Next, insert the Seat Knob (11) upward through the bracket on the Seat Post (5) into the hole in the Carriage Block (55). Then, tighten the Seat Knob.

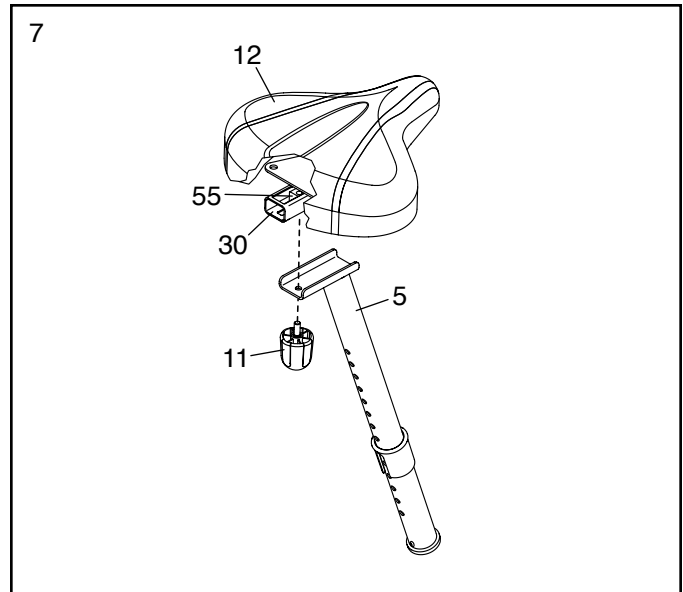

8. Loosen and remove the Seat Post Knob (48) from the Frame (1).

Next, insert the Seat Post (5) into the Frame (1), and press the Seat Post Bushing (20) downward into the Frame.

Slide the Seat Post (5) upward or downward to the desired position, and then insert the Seat Post Knob (48) into the Frame and into one of the adjustment holes in the Seat Post. Then, tighten the Seat Post Knob.

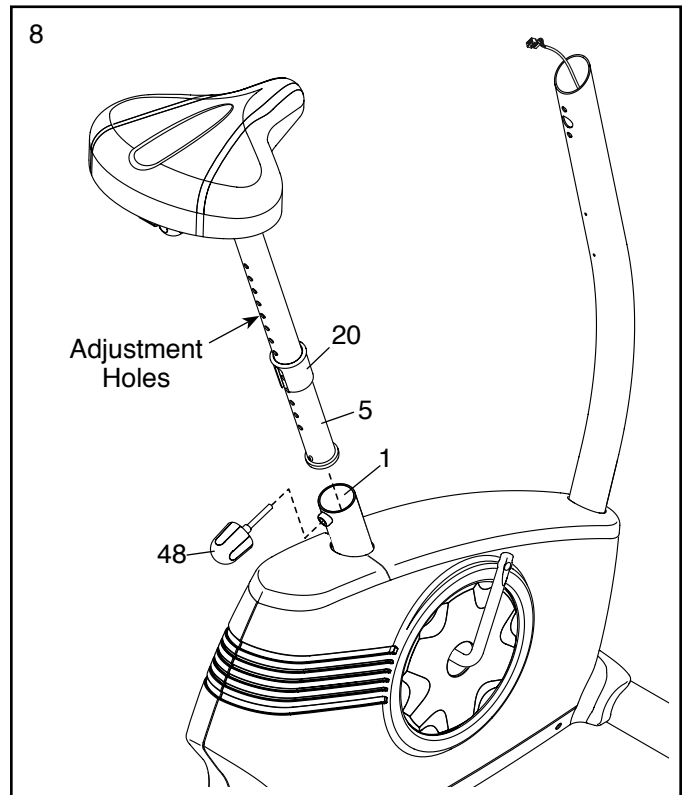

9. Hold the Console Plate (19) near the Upright (3). Insert the Main Wire (31) upward through the Console Plate.

Next, insert the Console Plate (19) into the Upright (3), and align the indicated large holes.

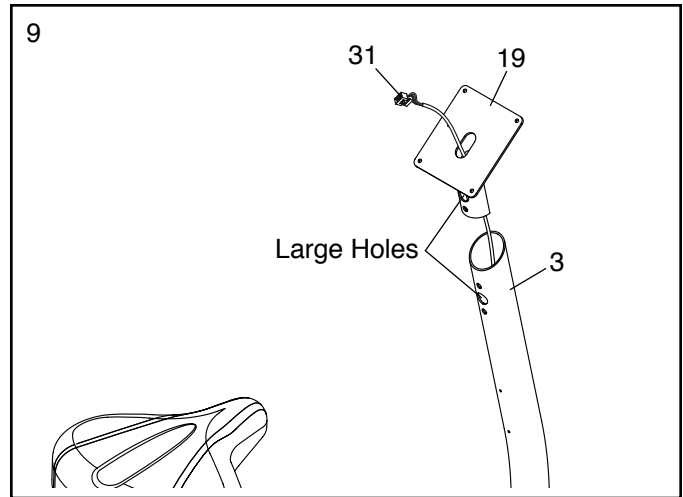

10. Have a second person hold the Handlebar (47) near the Upright (3).

Locate the Pulse Wire (52) in the Handlebar (47). Insert the Pulse Wire into the large hole in the Upright (3), and then pull the Pulse Wire out of the top of the Console Plate (19).

Attach the Handlebar (47) and the Console Plate (19) to the Upright (3) with two M8 x 25mm Button Screws (44) and two M8 Curved Washers (57).

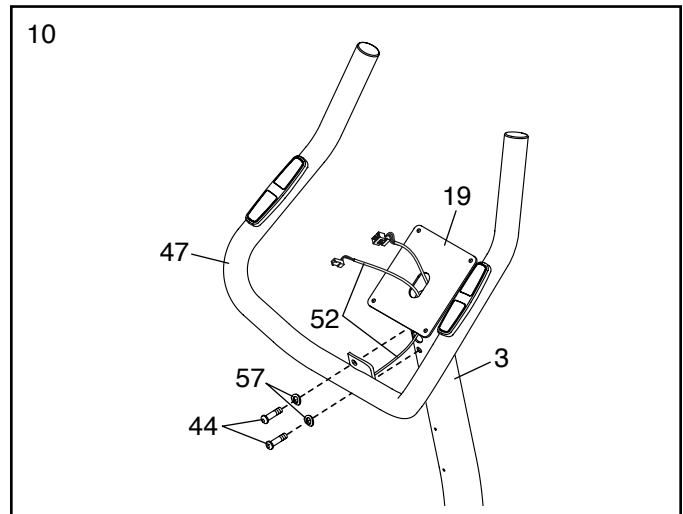

11. The Console (6) can use four D batteries (not included); alkaline batteries are recommended. Do not use old and new batteries together or alkaline, standard, and rechargeable batteries together. **IMPORTANT: If the Console has been exposed to cold temperatures, allow it to warm to room temperature before inserting batteries. Otherwise, you may damage the console displays or other electronic components.** Remove the screws and the battery covers from the back of the Console, and insert batteries into the battery compartments. **Make sure to orient the batteries as shown by the diagrams inside the battery compartments.** Then, reattach the battery covers.

**To purchase an optional power adapter, call the telephone number on the cover of this manual. To avoid damaging the console, use only a manufacturer-supplied power adapter.** Plug one end of the power adapter into the receptacle inside the battery compartment on the console; plug the other end into an outlet installed in accordance with all local codes and ordinances.

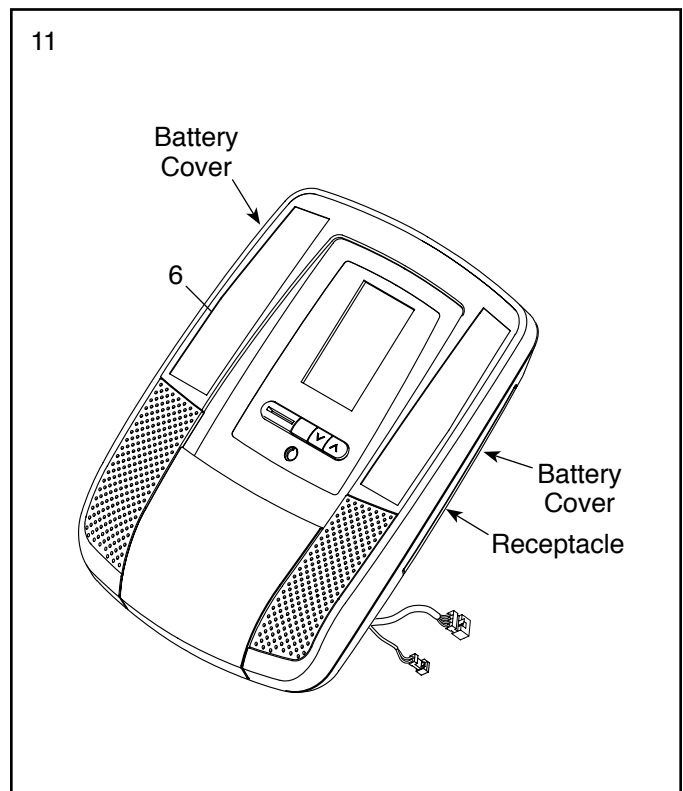

12. While a second person holds the Console (6) near the Console Plate (19), connect the wires on the Console to the Main Wire (31) and to the Pulse Wire (52).

Insert the excess wire into the Console Plate (19) or into the Console (6).

**Tip: Avoid pinching the wires.** Attach the Console (6) to the Console Plate (19) with four M4 x 16mm Screws (40).

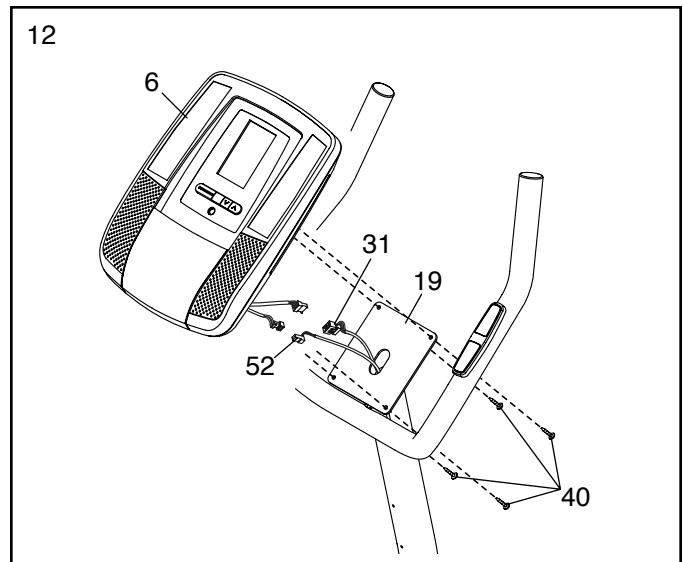

13. Attach the Water Bottle Holder (49) to the Upright (3) with two M4 x 22mm Screws (54).

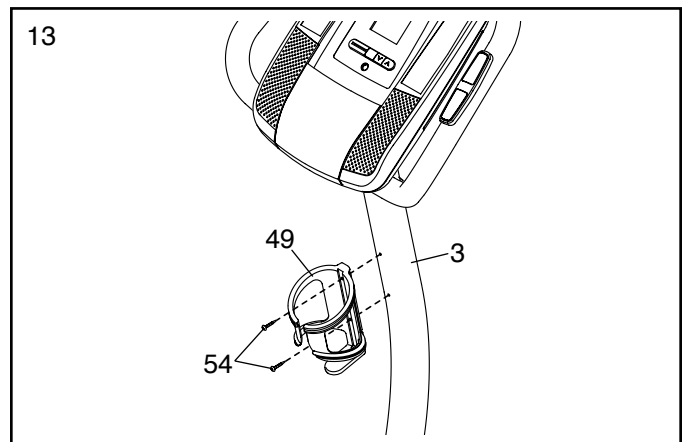

14. Identify the Right Pedal (26), which is marked with an "R." Using an adjustable wrench, firmly tighten the Right Pedal **clockwise** into the right arm of the Crank (13).

Tighten the Left Pedal (not shown) **counter-clockwise** into the left arm of the Crank (not shown).

Adjust the strap on the Right Pedal (26) to the desired position, and press the end of the strap onto the tab on the Right Pedal. **Adjust the strap on the Left Pedal (not shown) in the same way.**

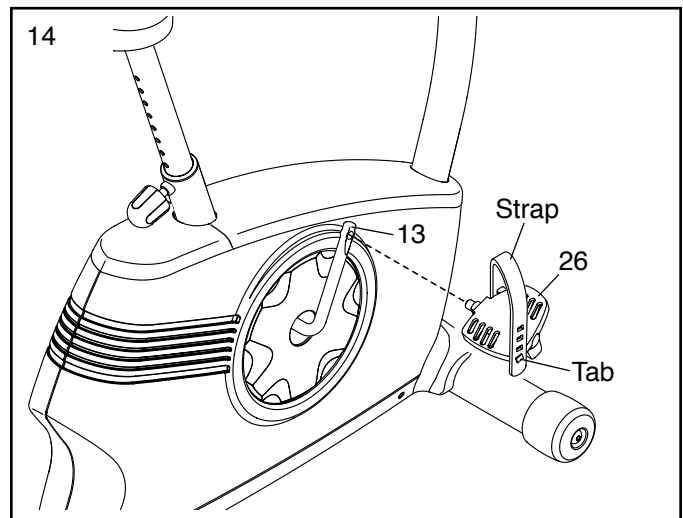

15. **Make sure that all parts of the exercise bike are properly tightened.** Note: Some hardware may be left over after assembly is completed. To protect the floor or carpet from damage, place a mat under the exercise bike.

# HOW TO USE THE EXERCISE BIKE

## HOW TO LEVEL THE EXERCISE BIKE

If the exercise bike rocks slightly on your floor during use, turn one or both of the leveling feet on the rear stabilizer until the rocking motion is eliminated.

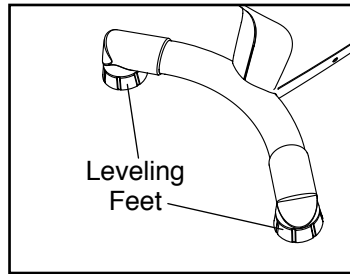

## HOW TO ADJUST THE SEAT

To adjust the position of the seat, loosen the seat knob, move the seat forward or backward to the desired position, and then firmly tighten the seat knob.

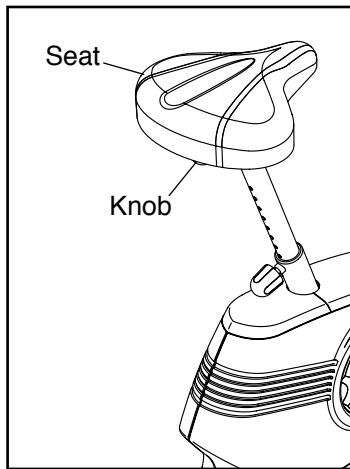

## HOW TO ADJUST THE SEAT POST

For effective exercise, the seat should be at the proper height. As you pedal, there should be a slight bend in your knees when the pedals are in the lowest position.

To adjust the seat post, first remove the seat post knob from the frame. Then, move the seat post upward or downward to the desired position, and insert the seat post knob into the frame and into one of the adjustment holes in the seat post. Then, tighten the seat post knob.

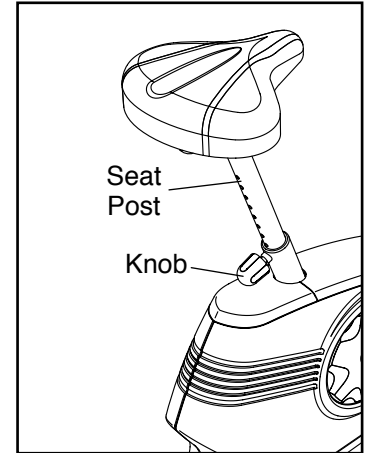

**IMPORTANT: Do not adjust the seat post beyond the stop mark on the seat post.**

## CONSOLE DIAGRAM

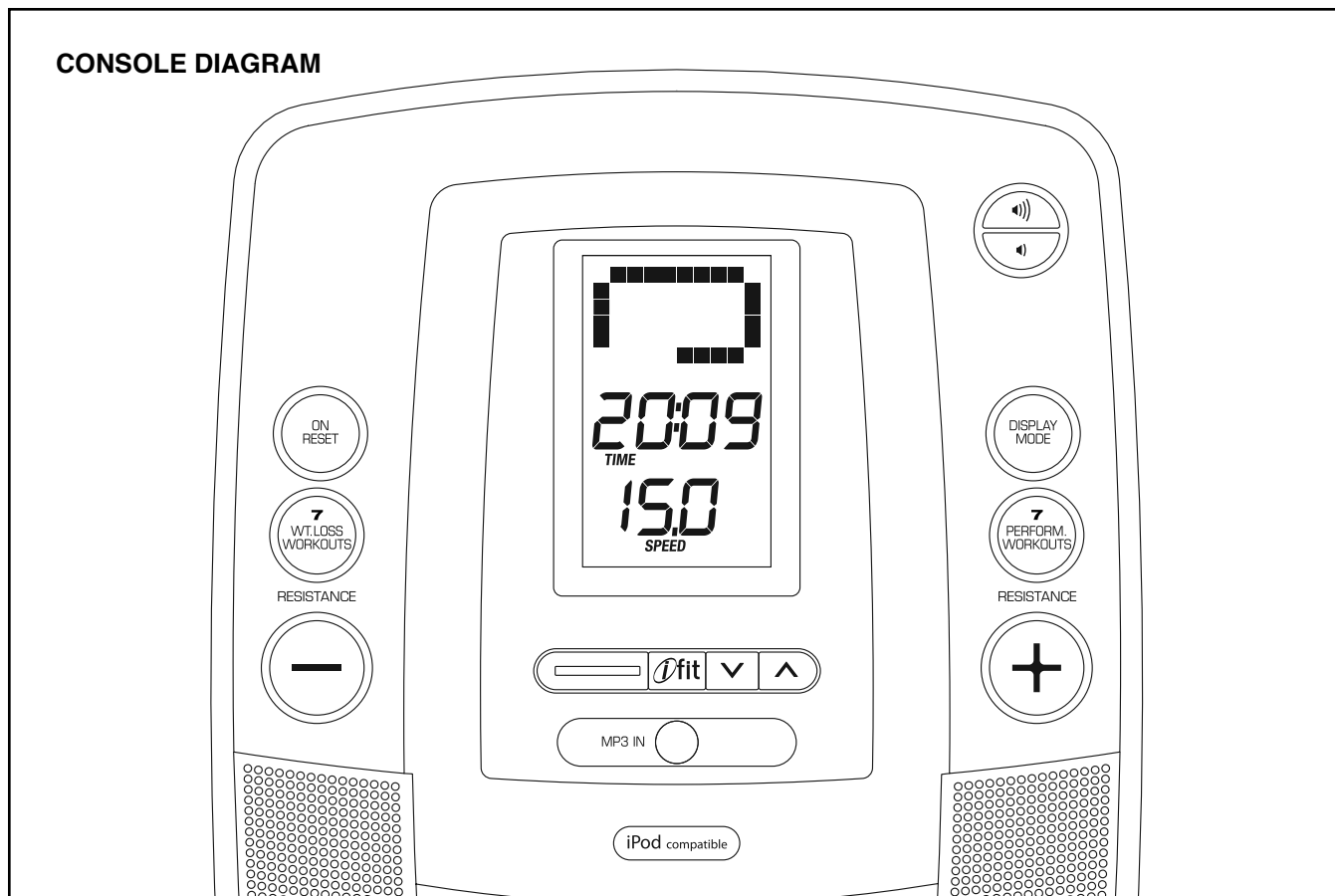

### FEATURES OF THE CONSOLE

The advanced console offers an array of features designed to make your workouts more effective and enjoyable.

When you use the manual mode of the console, you can change the resistance of the pedals with the touch of a button. As you exercise, the console will provide continuous exercise feedback. You can even measure your heart rate using the handgrip heart rate monitor.

The console offers fourteen preset workouts—seven weight loss and seven performance workouts. Each preset workout automatically changes the resistance of the pedals and prompts you to vary your pedaling speed as it guides you through an effective workout.

The console also features the iFit interactive workout system, which enables the console to accept iFit cards containing workouts designed to help you achieve specific fitness goals.

For example, lose unwanted pounds with the 8-week Weight Loss workout. iFit workouts control the resistance of the pedals while the voice of a personal trainer coaches you through your workouts. iFit cards are available separately. **To purchase iFit cards, go to [www.iFit.com](http://www.iFit.com) or call 1-888-533-1333. iFit cards are also available at select stores.**

You can even connect your MP3 player or CD player to the console sound system and listen to your favorite music or audio books while you exercise.

**To use the manual mode**, see page 14. **To use a preset workout**, see page 16. **To use an iFit Live workout**, see page 17. **To use the sound system**, see page 17. **To use the user mode**, see page 18.

**Note:** Before using the console, make sure that batteries are installed (see assembly step 11 on page 10). If there is a sheet of plastic on the display, remove the plastic.

## HOW TO USE THE MANUAL MODE

### 1. Turn on the console.

Press any button or begin pedaling to turn on the console.

When you turn on the console, the display will turn on. A tone will sound and the console will be ready for use.

### 2. Select the manual mode.

When you turn on the console, the manual mode will be selected automatically.

If you have selected a workout, reselect the manual mode by pressing the 7 Wt. Loss Workouts button or the 7 Perform. Workouts button repeatedly until a track appears in the upper display.

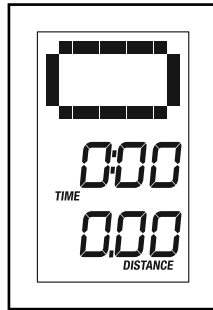

### 3. Begin pedaling and change the resistance of the pedals as desired.

As you pedal, change the resistance of the pedals by pressing the Resistance increase and decrease buttons.

Note: After you press the buttons, it will take a moment for the pedals to reach the selected resistance level.

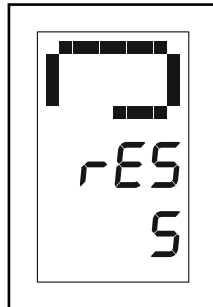

### 4. Follow your progress with the display.

The display can show the following workout information:

**Calories**—This display mode will show the approximate number of calories you have burned.

**Distance**—This display mode will show the distance that you have pedaled in miles or kilometers.

**Profile**—When a workout is selected, this display mode will show a profile of the resistance settings of the workout.

**Pulse**—This display mode will show your heart rate when you use the handgrip heart rate monitor (see step 5 on page 15).

**Resistance (Res)**—This display mode will show the resistance level of the pedals for a few seconds each time the resistance level changes.

**Speed**—This display mode will show your pedaling speed in miles per hour or kilometers per hour.

**Time**—When the manual mode is selected, this display mode will show the elapsed time. When a workout is selected, this display mode will show the time remaining in the workout.

**Track**—When the manual mode is selected, this display mode will show a track representing 1/4 mile (400 m). As you exercise, indicators will appear in succession around the track until the entire track appears. The track will then disappear and the indicators will again begin to appear in succession.

Press the Display Mode button repeatedly to view the desired workout information.

To reset the display to zero, press the On/Reset button.

Note: The console can show pedaling speed and distance in either miles or kilometers. To view or change the unit of measurement, see THE USER MODE on page 18.

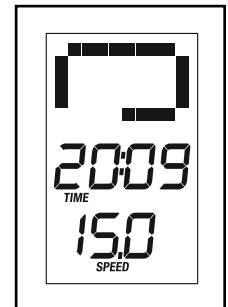

Change the volume level of the console by pressing the Volume increase and decrease buttons.

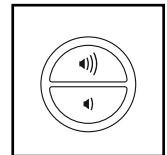

**5. Measure your heart rate if desired.**

**If there are sheets of plastic on the metal contacts on the handgrip heart rate monitor, remove the plastic. In addition, make sure that your hands are clean. To measure your heart rate, hold the handgrip heart rate monitor with your palms resting against the contacts. **Avoid moving your hands or gripping the contacts tightly.****

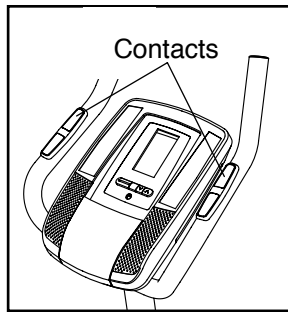

When your pulse is detected, a heart-shaped symbol will flash in the display and then your heart rate will be shown. For the most accurate heart rate reading, hold the contacts for at least 15 seconds.

If your heart rate is not shown, make sure that your hands are positioned as described. Be careful not to move your hands excessively or to squeeze the contacts tightly. For optimal performance, clean the contacts using a soft cloth; **never use alcohol, abrasives, or chemicals to clean the contacts.**

**6. When you are finished exercising, the console will turn off automatically.**

If the pedals do not move for several seconds, a series of tones will sound, the console will pause, and the time will flash in the display.

If the pedals do not move for several minutes, the console will turn off and the display will be reset.

## HOW TO USE A PRESET WORKOUT

### 1. Turn on the console.

Press any button or begin pedaling to turn on the console.

When you turn on the console, the display will turn on. A tone will sound and the console will be ready for use.

### 2. Select a preset workout.

To select a preset workout, press the 7 Wt. Loss Workouts button or the 7 Perform. Workouts button repeatedly until the number of the desired workout appears in the lower display.

When you select a preset workout, a profile of the resistance levels of the workout will scroll across the upper display, the duration of the workout will appear in the center display, and the number of the workout will appear in the lower display.

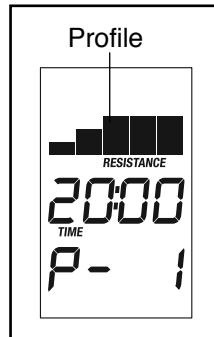

### 3. Begin pedaling to start the workout.

Each workout is divided into several one-minute segments. One resistance level and one goal speed is programmed for each segment. Note: The same resistance level and/or goal speed may be programmed for consecutive segments.

During the workout, the workout profile will show your progress (see the drawing above). The flashing segment of the profile represents the current segment of the workout. The height of the flashing segment indicates the resistance level for the current segment.

At the end of each segment of the workout, a series of tones will sound and the next segment of the profile will begin to flash. If a different resistance level is programmed for the next segment, the resistance level will appear in the display for a few seconds to alert you. The resistance of the pedals will then change.

As you exercise, keep your pedaling speed near the goal speed for the current segment. The goal speed will appear in the display when the speed display mode is selected.



**IMPORTANT: The goal speed is intended only to provide motivation. Your actual pedaling speed may be slower than the goal speed. Make sure to pedal at a speed that is comfortable for you.**

If the resistance level for the current segment is too high or too low, you can manually override the setting by pressing the Resistance buttons. **IMPORTANT: When the current segment of the workout ends, the pedals will automatically adjust to the resistance level programmed for the next segment.**

If you stop pedaling for several seconds, a series of tones will sound and the workout will pause.

To resume the workout, simply resume pedaling. The workout will continue until the last segment of the profile flashes and the last segment of the workout ends.

### 4. Follow your progress with the display.

See step 4 on page 14.

### 5. Measure your heart rate if desired.

See step 5 on page 15.

### 6. When you are finished exercising, the console will turn off automatically.

See step 6 on page 15.



## HOW TO USE AN IFIT WORKOUT

iFit cards are available separately. To purchase iFit cards, go to [www.iFit.com](http://www.iFit.com) or call 1-888-533-1333. iFit cards are also available at select stores.

### 1. Turn on the console.

Press any button or begin pedaling to turn on the console.

When you turn on the console, the display will turn on. A tone will sound and the console will be ready for use.

### 2. Insert an iFit card and select a workout.

To use an iFit workout, insert an iFit card into the iFit slot; make sure that the iFit card is oriented so that the metal contacts are face down and are facing the slot. When the iFit card is properly inserted, the indicator next to the slot will turn on.

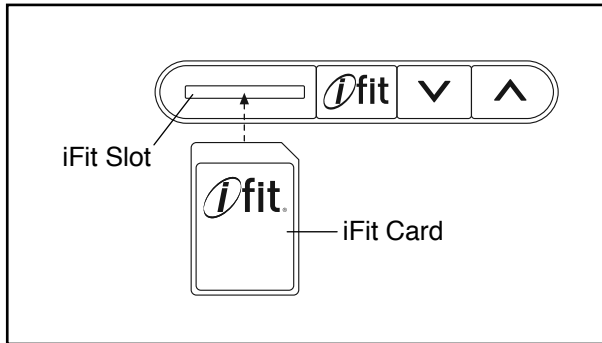

Next, select the desired workout on the iFit card by pressing the increase and decrease buttons next to the iFit slot.

A profile of the resistance levels of the workout will scroll across the upper display, the duration of the workout will appear in the center display, and the number of the workout will appear in the lower display.

A moment after you select a workout, the voice of a personal trainer will begin guiding you through your workout. iFit workouts function in the same way as preset workouts. To use the workout, see steps 3 to 6 starting on page 16.

### 3. When you are finished exercising, remove the iFit card.

Remove the iFit card when you are finished exercising. Store the iFit card in a secure place.

## HOW TO USE THE SOUND SYSTEM

To play music or audio books through the console sound system while you exercise, plug the included audio cable into the jack on the console and into a jack on your MP3 player or CD player; **make sure that the audio cable is fully plugged in.**

Next, press the Play button on your MP3 player or CD player. Adjust the volume level using the Volume increase and decrease buttons on the console or the volume control on your MP3 player or CD player.

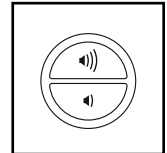

## THE USER MODE

The console features a user mode that allows you to select a unit of measurement for the console and to view console usage information.

### 1. Select the user mode.

To select the user mode, press and hold down the Display Mode button for a few seconds until the user mode information appears in the display.

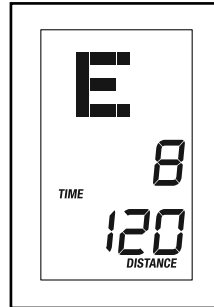

### 2. Select a unit of measurement if desired.

The console can show pedaling speed and distance in either miles or kilometers.

The upper display will show the selected unit of measurement. An E for English miles or an M for metric kilometers will appear in the upper display. To change the unit of measurement, press the Resistance decrease button repeatedly.

Note: When you replace the batteries, it may be necessary to reselect the unit of measurement.

### 3. View console usage information if desired.

The center display will show the total number of hours that the console has been used since the exercise bike was purchased. The lower display will show the total distance that the pedals have moved since the exercise bike was purchased.

### 4. Exit the user mode.

Press the Display Mode button to exit the user mode.

---

## FCC INFORMATION

This equipment has been tested and found to comply with the limits for a Class B digital device, pursuant to part 15 of the FCC Rules. These limits are designed to provide reasonable protection against harmful interference in a residential installation. This equipment generates, uses, and can radiate radio frequency energy and, if not installed and used in accordance with the instructions, may cause harmful interference to radio communications. However, there is no guarantee that interference will not occur in a particular installation. If this equipment does cause harmful interference to radio or television reception, which can be determined by turning the equipment off and on, try to correct the interference by one or more of the following measures:

- Reorient or relocate the receiving antenna.
- Increase the separation between the equipment and the receiver.
- Connect the equipment into an outlet on a circuit different from that to which the receiver is connected.
- Consult the dealer or an experienced radio/TV technician for help.

**FCC CAUTION: To assure continued compliance, use only shielded interface cables when connecting to computer or peripheral devices. Changes or modifications not expressly approved by the party responsible for compliance could void the user's authority to operate this equipment.**

# MAINTENANCE AND TROUBLESHOOTING

Inspect and tighten all parts of the exercise bike regularly. Replace any worn parts immediately.

To clean the exercise bike, use a damp cloth and a small amount of mild soap. **IMPORTANT: To avoid damage to the console, keep liquids away from the console and keep the console out of direct sunlight.**

## CONSOLE TROUBLESHOOTING

If the console display becomes dim, replace all the batteries at the same time; most console problems are the result of low batteries. See assembly step 11 on page 10 for replacement instructions.

If the console does not display your heart rate when you use the handgrip heart rate monitor, see step 5 on page 15.

## HOW TO ADJUST THE REED SWITCH

If the console does not display correct feedback, the reed switch should be adjusted.

Using a flat screwdriver, remove the Top Shield Cap (10). Then, remove the two M4 x 16mm Screws (40) and lift the Top Shield (9) away from the frame.

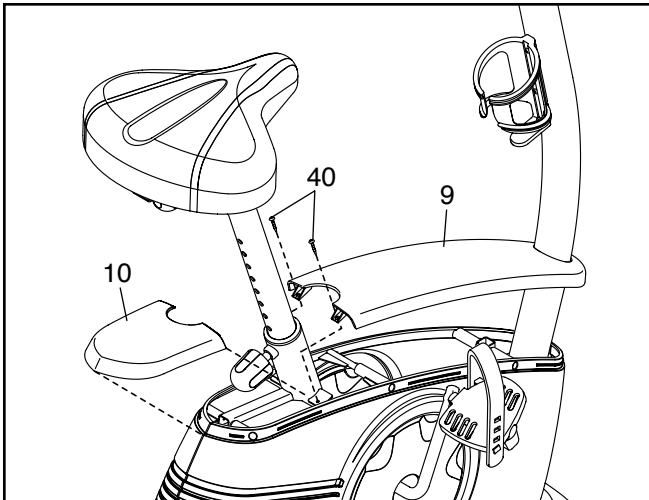

Next, locate the Reed Switch (21). Loosen, but do not remove, the M4 x 16mm Screw (40).

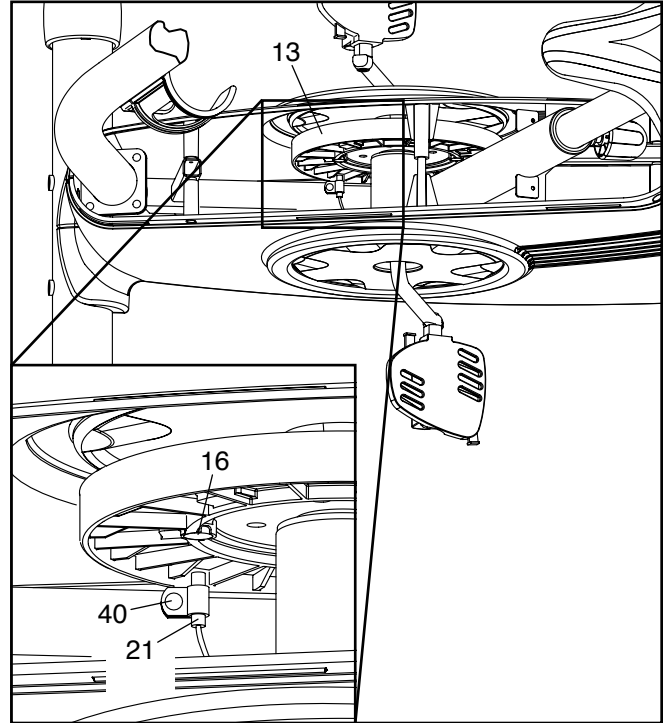

Rotate the Pulley (13) until a Pulley Magnet (16) is aligned with the Reed Switch (21). Slide the Reed Switch slightly toward or away from the Pulley Magnet. Then, retighten the M4 x 16mm Screw (40).

Rotate the pulley for a moment. Repeat these actions until the console displays correct feedback.

When the reed switch is correctly adjusted, reattach the top shield and the top shield cap.

## HOW TO ADJUST THE DRIVE BELT

If you can feel the pedals slip while you are pedaling, even when the resistance is adjusted to the highest level, the drive belt may need to be adjusted.

To adjust the drive belt, you must remove the top shield cap, the top shield, and the right shield (see the instructions below).

Using a flat screwdriver, remove the Top Shield Cap (10). Then, remove the two M4 x 16mm Screws (40) and lift the Top Shield (9) away from the frame.

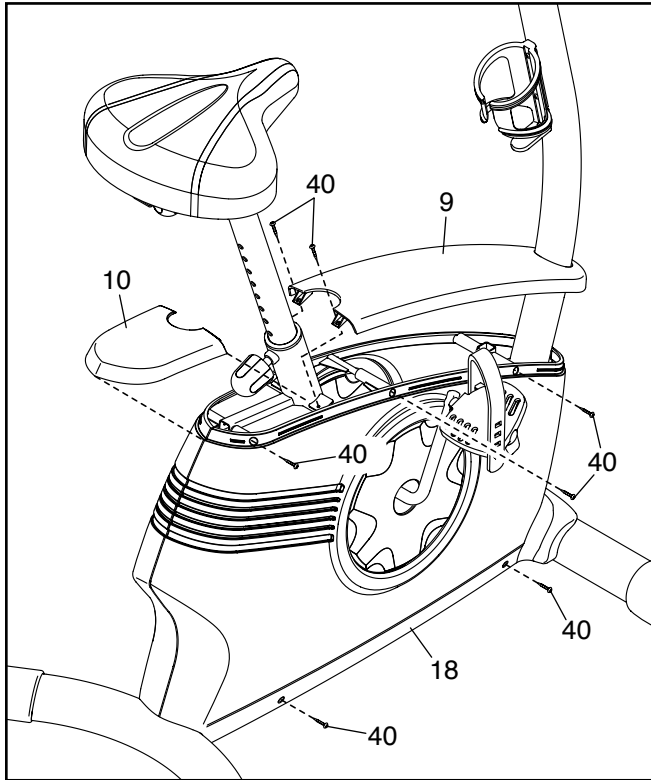

Remove the five M4 x 16mm Screws (40) from the Right Shield (18). Then, gently move the Right Shield away from the frame.

**Tip: It may be necessary to remove the right pedal.** Using an adjustable wrench, turn the right pedal counterclockwise and remove it.

Hold the two M8 Locknuts (37) and loosen the two M8 x 16mm Screws (53). Next, loosen the M10 x 50mm Screw (33) until the Drive Belt (23) is tight. Then, hold the M8 Locknuts and tighten the M8 x 16mm Screws.

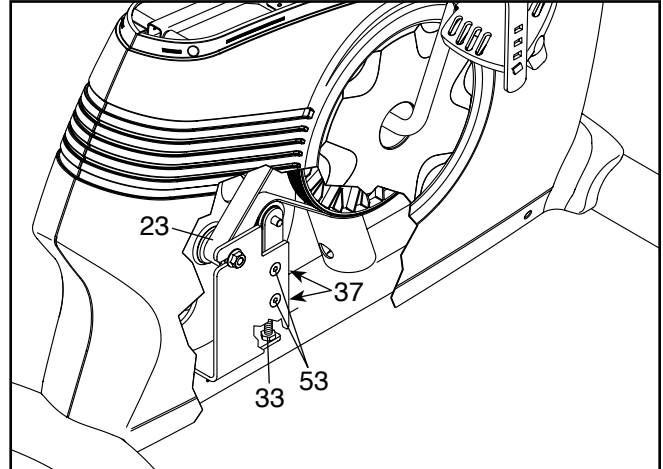

Then, reattach the right shield, the top shield, and the top shield cap. Reattach the right pedal, if necessary.

# EXERCISE GUIDELINES

**⚠️ WARNING:** Before beginning this or any exercise program, consult your physician. This is especially important for persons over age 35 or persons with pre-existing health problems.

The heart rate monitor is not a medical device. Various factors may affect the accuracy of heart rate readings. The heart rate monitor is intended only as an exercise aid in determining heart rate trends in general.

These guidelines will help you to plan your exercise program. For detailed exercise information, obtain a reputable book or consult your physician. Remember, proper nutrition and adequate rest are essential for successful results.

## EXERCISE INTENSITY

Whether your goal is to burn fat or to strengthen your cardiovascular system, exercising at the proper intensity is the key to achieving results. You can use your heart rate as a guide to find the proper intensity level. The chart below shows recommended heart rates for fat burning and aerobic exercise.

165	155	145	140	130	125	115	♥♥
145	138	130	125	118	110	103	♥
125	120	115	110	105	95	90	♥
<hr/>							
20	30	40	50	60	70	80	

To find the proper intensity level, find your age at the bottom of the chart (ages are rounded off to the nearest ten years). The three numbers listed above your age define your “training zone.” The lowest number is the heart rate for fat burning, the middle number is the heart rate for maximum fat burning, and the highest number is the heart rate for aerobic exercise.

**Burning Fat**—To burn fat effectively, you must exercise at a low intensity level for a sustained period of time. During the first few minutes of exercise, your body uses carbohydrate calories for energy. Only after the first few minutes of exercise does your body begin to use stored fat calories for energy. If your goal is to burn fat, adjust the intensity of your exercise until your heart rate is near the lowest number in your training zone. For maximum fat burning, exercise with your heart rate near the middle number in your training zone.

**Aerobic Exercise**—If your goal is to strengthen your cardiovascular system, you must perform aerobic exercise, which is activity that requires large amounts of oxygen for prolonged periods of time. For aerobic exercise, adjust the intensity of your exercise until your heart rate is near the highest number in your training zone.

## WORKOUT GUIDELINES

**Warming Up**—Start with 5 to 10 minutes of stretching and light exercise. A warm-up increases your body temperature, heart rate, and circulation in preparation for exercise.

**Training Zone Exercise**—Exercise for 20 to 30 minutes with your heart rate in your training zone. (During the first few weeks of your exercise program, do not keep your heart rate in your training zone for longer than 20 minutes.) Breathe regularly and deeply as you exercise—never hold your breath.

**Cooling Down**—Finish with 5 to 10 minutes of stretching. Stretching increases the flexibility of your muscles and helps to prevent post-exercise problems.

## EXERCISE FREQUENCY

To maintain or improve your condition, complete three workouts each week, with at least one day of rest between workouts. After a few months of regular exercise, you may complete up to five workouts each week, if desired. Remember, the key to success is to make exercise a regular and enjoyable part of your everyday life.

# PART LIST

Model No. 831.21941.2 R0112A

Key No.	Qty.	Description	Key No.	Qty.	Description
1	1	Frame	31	1	Main Wire
2	1	Front Stabilizer	32	1	M10 Flange Nut
3	1	Upright	33	1	M10 x 50mm Screw
4	2	Stabilizer Cap	34	1	Resistance Cable
5	1	Seat Post	35	3	M4.2 x 16mm Screw
6	1	Console	36	2	M10 x 80mm Button Screw
7	1	Flywheel Assembly	37	6	M8 Locknut
8	1	Audio Cable	38	2	M10 x 41mm Button Screw
9	1	Top Shield	39	1	M8 Flange Nut
10	1	Top Shield Cap	40	17	M4 x 16mm Screw
11	1	Seat Knob	41	4	M4 x 12mm Flange Screw
12	1	Seat	42	1	Flywheel Axle
13	1	Pulley/Crank	43	4	M8 x 60mm Button Screw
14	1	Rear Stabilizer	44	6	M8 x 25mm Button Screw
15	2	Wheel	45	8	M8 Split Washer
16	2	Pulley Magnet	46	2	Pulse Sensor
17	1	Left Shield	47	1	Handlebar
18	1	Right Shield	48	1	Seat Post Knob
19	1	Console Plate	49	1	Water Bottle Holder
20	1	Seat Post Bushing	50	2	Leveling Foot
21	1	Reed Switch/Wire	51	2	Handlebar Cap
22	1	Reed Switch Clamp	52	1	Pulse Wire
23	1	Drive Belt	53	2	M8 x 16mm Screw
24	1	Left Pedal/Strap	54	2	M4 x 22mm Screw
25	1	Idler	55	1	Carriage Block
26	1	Right Pedal/Strap	56	4	M8 Washer
27	1	Crank Bearing Set	57	2	M8 Curved Washer
28	1	Seat Post Cap	*	–	User's Manual
29	1	Resistance Motor	*	–	Assembly Tool
30	1	Seat Carriage			

Note: Specifications are subject to change without notice. For information about ordering replacement parts, see the back cover of this manual. **If a part is missing, call 1-888-533-1333.** \*These parts are not illustrated.

# EXPLODED DRAWING

Model No. 831.21941.2 R0112A

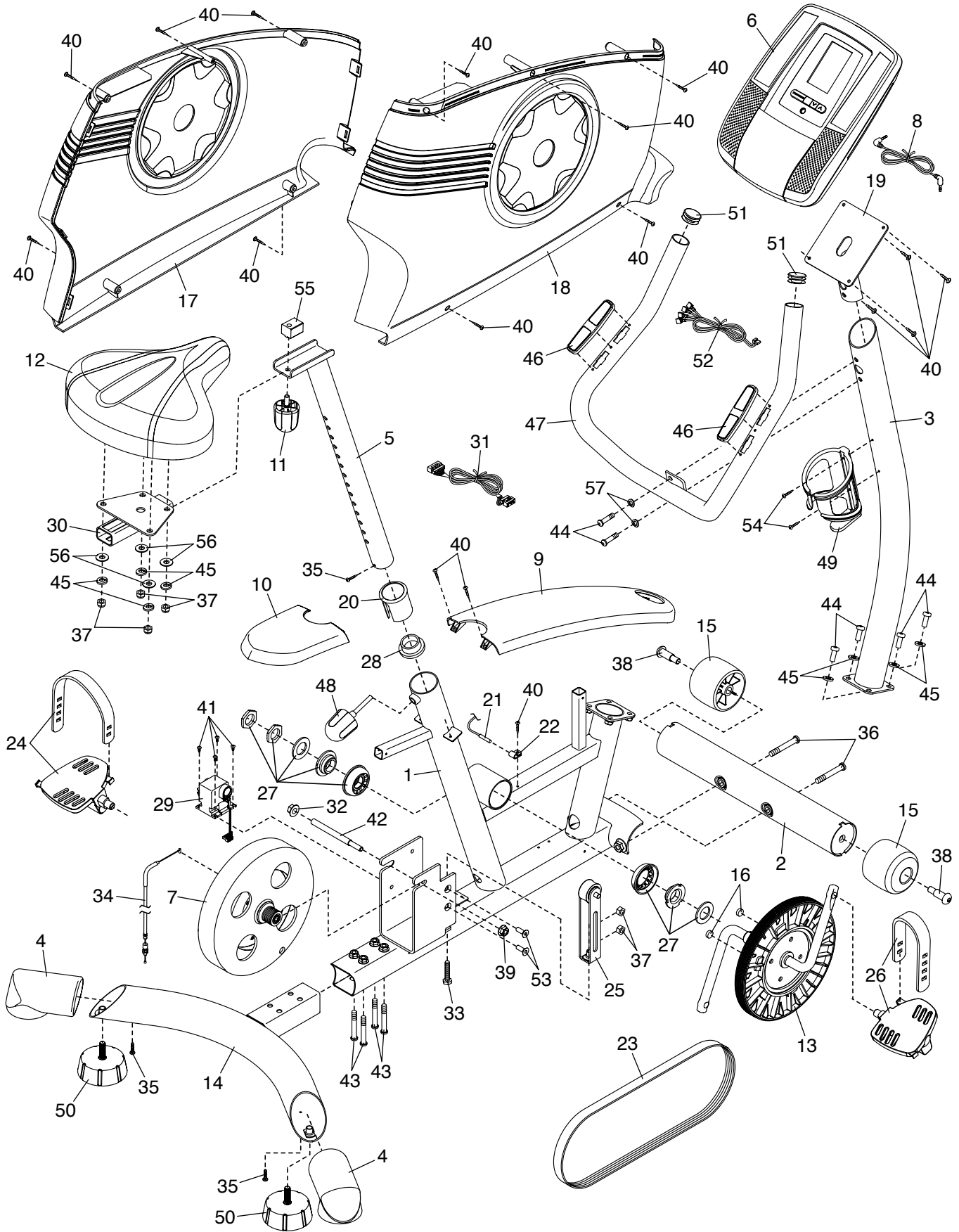

## Get it fixed, at your home or ours!

### Your Home

For repair—in **your home**—of **all** major brand appliances, lawn and garden equipment, or heating and cooling systems, **no matter who made it, no matter who sold it!**

For the replacement parts, accessories, and user's manuals that you need to do-it-yourself.

For Sears professional installation of home appliances and items like garage door openers and water heaters.

**1-800-4-MY-HOME® (1-800-469-4663)**

Call anytime, day or night (U.S.A. and Canada)

[www.sears.com](http://www.sears.com)

[www.sears.ca](http://www.sears.ca)

### Our Home

For repair of carry-in items like vacuums, lawn equipment, and electronics, call or go on-line for the location of your nearest **Sears Parts & Repair Center.**

**1-800-488-1222** Call anytime, day or night (U.S.A. only)

[www.sears.com](http://www.sears.com)

To purchase a protection agreement (U.S.A.) or maintenance agreement (Canada) on a product serviced by Sears:

**1-800-827-6655** (U.S.A.)

**1-800-361-6665** (Canada)

Para pedir servicio de reparación a domicilio, y para ordenar piezas:

**1-888-SU-HOGAR® (1-888-784-6427)**



® Registered Trademark / ™ Trademark / ™ Service Mark of Sears Brands, LLC  
® Marca Registrada / ™ Marca de Fábrica / ™ Marca de Servicio de Sears Brands, LLC

## 90 DAY FULL WARRANTY

If this Sears Bike Exerciser fails due to a defect in material or workmanship within 90 days of the date of purchase, call 1-800-4-MY-HOME® (1-800-469-4663) to arrange for free repair (or replacement if repair proves impossible). There is a 5 year warranty on the frame.

This warranty does not apply when the Bike Exerciser is used commercially or for rental purposes.

This warranty gives you specific legal rights, and you may also have other rights which vary from state to state.

**Sears, Roebuck and Co., Hoffman Estates, IL 60179**