

NordicTrack[®] T 5.7

www.nordictrack.com

Model No. NTL61011.1

Serial No. _____

Write the serial number in the space above for reference.

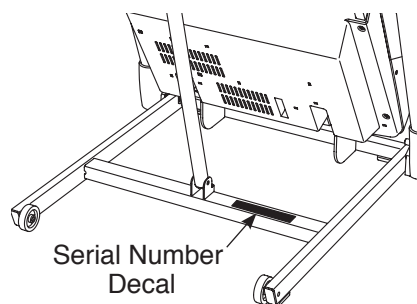

USER'S MANUAL

QUESTIONS?

If you have questions, or if parts are damaged or missing, **DO NOT CONTACT THE STORE**; please contact Customer Care.

IMPORTANT: Please register this product (see the limited warranty on the back cover of this manual) before contacting Customer Care.

CALL TOLL-FREE:

1-800-TO-BE-FIT

(1-800-862-3348)

Mon.–Fri. 6 a.m.–6 p.m. MT

Sat. 8 a.m.–4 p.m. MT

ON THE WEB:

www.nordictrackservice.com

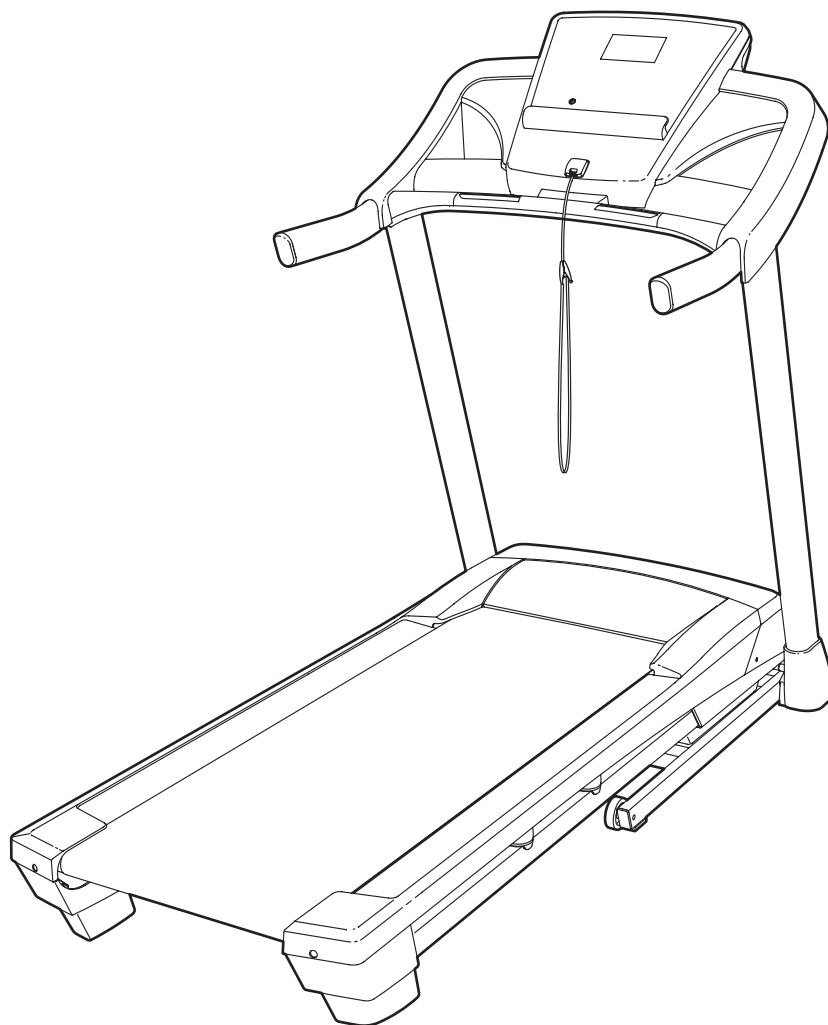

CAUTION

Read all precautions and instructions in this manual before using this equipment. Keep this manual for future reference.

FREE



www.iFit.com

TABLE OF CONTENTS



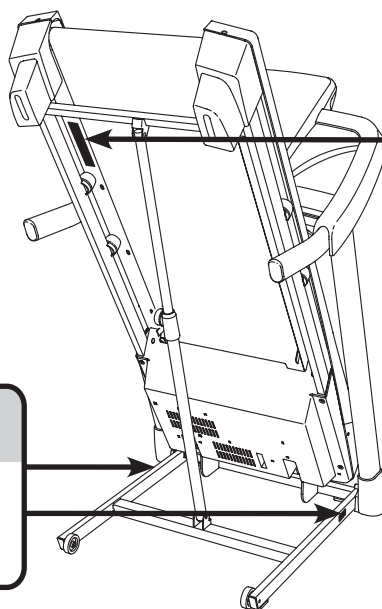

WARNING DECAL PLACEMENT	2
IMPORTANT PRECAUTIONS	3
BEFORE YOU BEGIN	5
PART IDENTIFICATION CHART	6
ASSEMBLY	7
OPERATION AND ADJUSTMENT	14
HOW TO FOLD AND MOVE THE TREADMILL	22
TROUBLESHOOTING	23
EXERCISE GUIDELINES	26
PART LIST	27
EXPLODED DRAWING	28
ORDERING REPLACEMENT PARTS	Back Cover
LIMITED WARRANTY	Back Cover

WARNING DECAL PLACEMENT

This drawing shows the locations of the warning decals. **If a decal is missing or illegible, call the telephone number on the front cover of this manual and request a free replacement decal. Apply the decal in the location shown. Note:** The decals may not be shown at actual size.



▲WARNING:
Protect yourself and others from risk of serious injury. Read the user's manual and :

-  •Stand only on the side rails when starting or stopping treadmill.
- Change speed in small increments.
- Hold handrails to prevent falling, and always wear the safety clip while operating treadmill.
- Stop if you feel faint, dizzy, or short of breath.
- Fully engage storage latch before treadmill is moved or stored.
- Reduce incline to its lowest level before folding treadmill into storage position.
-  •Never allow children on or around treadmill.
- Remove key when not in use.
-  •Keep clothing, fingers, and hair away from moving belt.
- Never try to adjust or fix the belt while it is moving.
-  •Always wear athletic shoes while operating treadmill.

IMPORTANT PRECAUTIONS

⚠ WARNING: To reduce the risk of serious injury, read all important precautions and instructions in this manual and all warnings on your treadmill before using your treadmill. ICON assumes no responsibility for personal injury or property damage sustained by or through the use of this product.

1. Before beginning any exercise program, consult your physician. This is especially important for persons over age 35 or persons with pre-existing health problems.
2. It is the responsibility of the owner to ensure that all users of this treadmill are adequately informed of all warnings and precautions.
3. Use the treadmill only as described.
4. Keep the treadmill indoors, away from moisture and dust. Do not put the treadmill in a garage or covered patio, or near water.
5. Place the treadmill on a level surface, with at least 8 ft. (2.4 m) of clearance behind it and 2 ft. (0.6 m) on each side. Do not place the treadmill on any surface that blocks air openings. To protect the floor or carpet from damage, place a mat under the treadmill.
6. Do not operate the treadmill where aerosol products are used or where oxygen is being administered.
7. Keep children under age 12 and pets away from the treadmill at all times.
8. The treadmill should be used only by persons weighing 325 lbs. (147 kg) or less.
9. Never allow more than one person on the treadmill at a time.
10. Wear appropriate exercise clothes while using the treadmill. Do not wear loose clothes that could become caught in the treadmill. Athletic support clothes are recommended for both men and women. *Always wear athletic shoes. Never use the treadmill with bare feet, wearing only stockings, or in sandals.*
11. When connecting the power cord (see page 14), plug the power cord into a surge suppressor (not included) and plug the surge suppressor into a grounded circuit capable of carrying 15 or more amps. No other appliance should be on the same circuit. Do not use an extension cord.
12. Use only a single-outlet surge suppressor that meets all of the specifications described on page 14. To purchase a surge suppressor, see your local NORDICTRACK dealer or call the telephone number on the front cover of this manual and order part number 146148, or see your local electronics store.
13. Failure to use a properly-functioning surge suppressor could result in damage to the control system of the treadmill. If the control system is damaged, the walking belt may slow, accelerate, or stop unexpectedly, which may result in a fall and serious injury.
14. Keep the power cord and the surge suppressor away from heated surfaces.
15. Never move the walking belt while the power is turned off. Do not operate the treadmill if the power cord or plug is damaged, or if the treadmill is not working properly. (See TROUBLESHOOTING on page 23 if the treadmill is not working properly.)
16. Read, understand, and test the emergency stop procedure before using the treadmill (see HOW TO TURN ON THE POWER on page 16).
17. Never start the treadmill while you are standing on the walking belt. Always hold the handrails while using the treadmill.
18. The treadmill is capable of high speeds. Adjust the speed in small increments to avoid sudden jumps in speed.
19. The heart rate monitor is not a medical device. Various factors, including the user's movement, may affect the accuracy of heart rate readings. The heart rate monitor is intended only as an exercise aid in determining heart rate trends in general.

20. Never leave the treadmill unattended while it is running. Always remove the key, unplug the power cord, and press the power switch into the off position when the treadmill is not in use. (See the drawing on page 5 for the location of the power switch.)
21. Do not attempt to raise, lower, or move the treadmill until it is properly assembled. (See ASSEMBLY on page 7, and HOW TO FOLD AND MOVE THE TREADMILL on page 22.) You must be able to safely lift 45 lbs. (20 kg) to raise, lower, or move the treadmill.
22. When folding or moving the treadmill, make sure that the storage latch is holding the frame securely in the storage position.
23. Never insert any object into any opening on the treadmill.
24. Inspect and properly tighten all parts of the treadmill regularly.
25. **DANGER:** Always unplug the power cord immediately after use, before cleaning the treadmill, and before performing the maintenance and adjustment procedures described in this manual. Never remove the motor hood unless instructed to do so by an authorized service representative. Servicing other than the procedures in this manual should be performed by an authorized service representative only.
26. This treadmill is intended for home use only. Do not use this treadmill in a commercial, rental, or institutional setting.
27. Over exercising may result in serious injury or death. If you feel faint or if you experience pain while exercising, stop immediately and cool down.

SAVE THESE INSTRUCTIONS

BEFORE YOU BEGIN

Thank you for selecting the new NORDICTRACK® T5.7 treadmill. The T5.7 treadmill provides an impressive selection of features designed to make your workouts at home more effective and enjoyable.

For your benefit, read this manual carefully before you use the treadmill. If you have questions after reading this manual, please see the front cover of this

manual. To help us assist you, note the product model number and serial number before contacting us. The model number and the location of the serial number decal are shown on the front cover of this manual.

Before reading further, please familiarize yourself with the parts that are labeled in the drawing below.

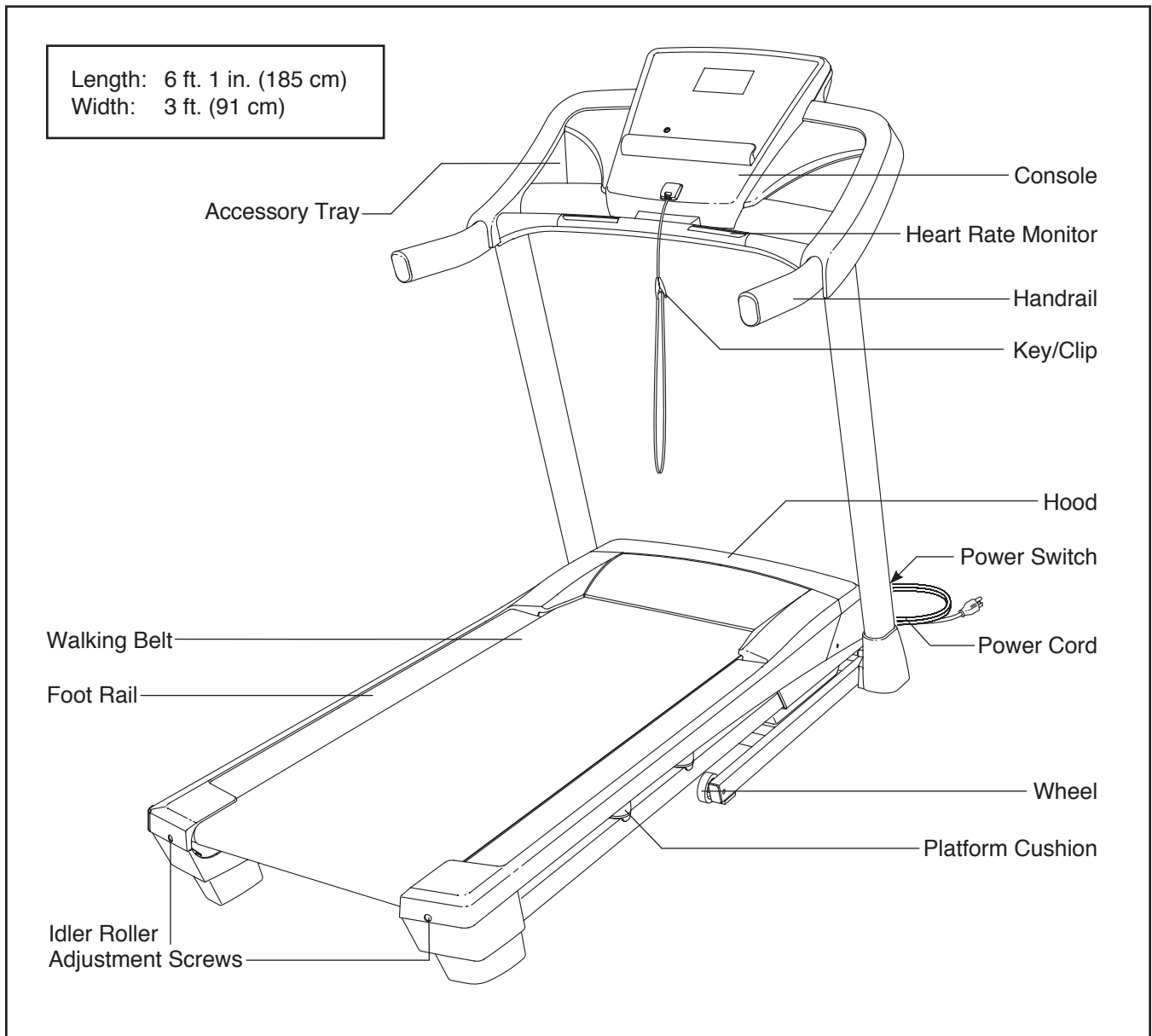

PART IDENTIFICATION CHART

Use the drawings below to identify small parts used for assembly. The number in parentheses below each drawing is the key number of the part, from the PART LIST near the end of this manual. The number following the key number is the quantity used for assembly. **Note: If a part is not in the hardware kit, check to see if it is pre-attached. Extra hardware may be included.**

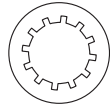

5/16" Star Washer (8)-2

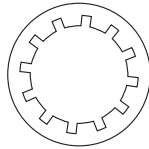

3/8" Star Washer (5)-10

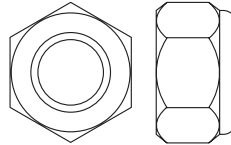

3/8" Nut (3)-4

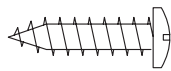

#8 x 3/4" Screw (6)-12

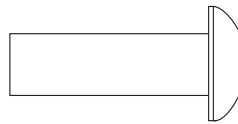

5/16" x 1" Screw (7)-2

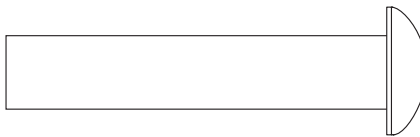

3/8" x 2" Bolt (12)-2

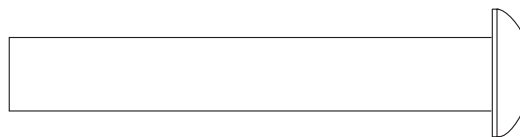

3/8" x 2 1/2" Bolt (2)-2

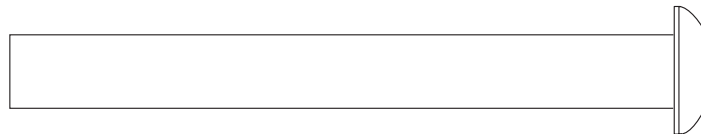

3/8" x 3 1/2" Screw (9)-4

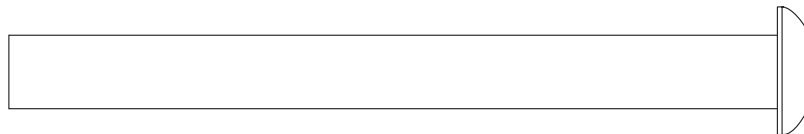





3/8" x 4" Screw (4)-6

ASSEMBLY

- Assembly requires two persons.
- Place all parts in a cleared area and remove the packing materials. Do not dispose of the packing materials until you finish all assembly steps.
- The underside of the walking belt is coated with high-performance lubricant. After shipping, there may be some lubricant on top of the walking belt or on the shipping carton. This is normal. If there is lubricant on top of the walking belt, wipe it off with a soft cloth and a mild, non-abrasive cleaner.
- To identify small parts, see page 6.

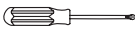
- Assembly requires the following tools:

the included hex keys	
one adjustable wrench	
one Phillips screwdriver	
scissors	
needlenose pliers	

To avoid damaging parts, do not use power tools.

1. Make sure that the power cord is unplugged.

Locate the Upright Wire (70) bundled around the front of the Base (80) beneath the Belly Pan (68). Cut the plastic tie securing the Upright Wire. Route the Upright Wire into the Base and out of the indicated hole.

Press a Base Cap (77) into each side of the Base (80).

See the inset drawing. Cut the plastic tie near the Upright Wire (70). **Be careful not to damage the Upright Wire.**

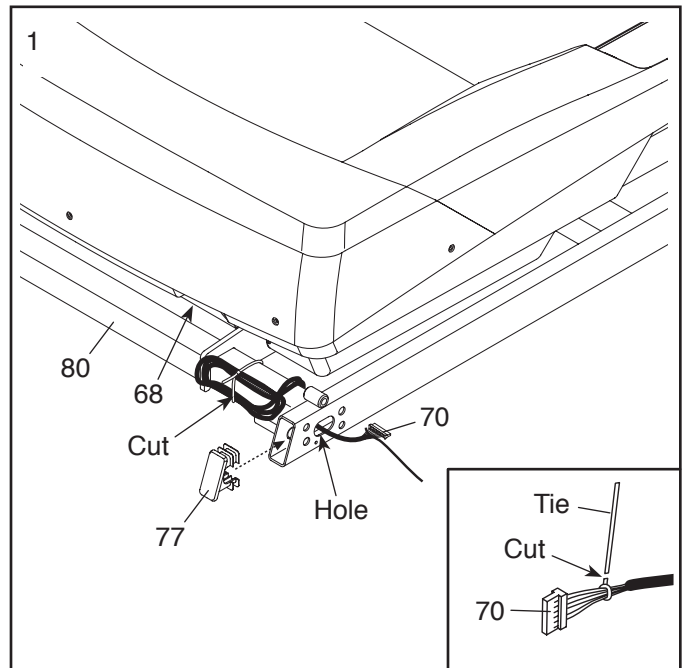

- Identify the Left Upright (75), which is marked "Left." Have a second person hold the Left Upright near the Base (80).

See the inset drawing. Tie the wire tie in the Left Upright (75) securely around the end of the Upright Wire (70). Then, insert the Upright Wire into the lower end of the Left Upright as you pull the other end of the wire tie through the Left Upright.

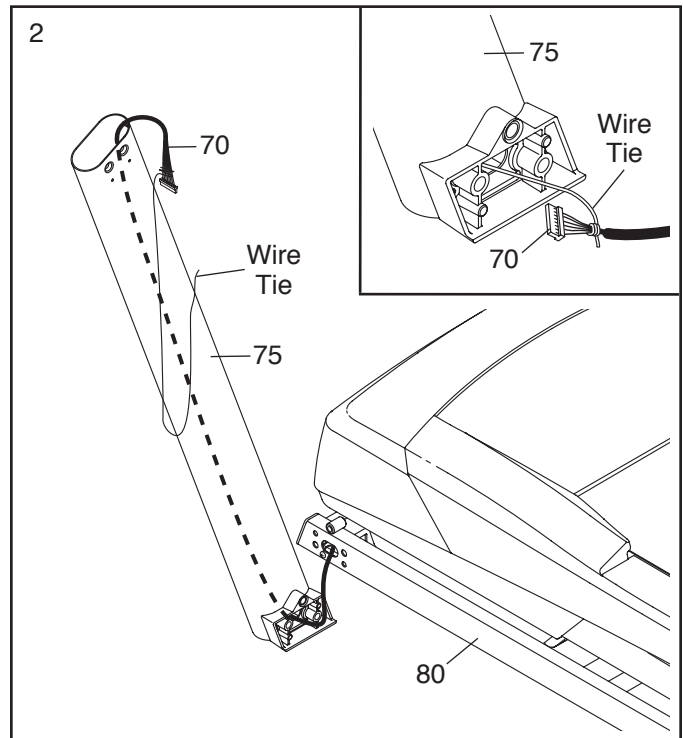

- With the help of a second person, hold the Left Upright (75) against the Base (80). **Be careful not to pinch the wires.** Partially tighten three 3/8" x 4" Screws (4) with three 3/8" Star Washers (5) into the Left Upright and the Base; **do not fully tighten the Screws yet.**

Attach the Right Upright (not shown) in the same way. Note: There are no wires on the right side.

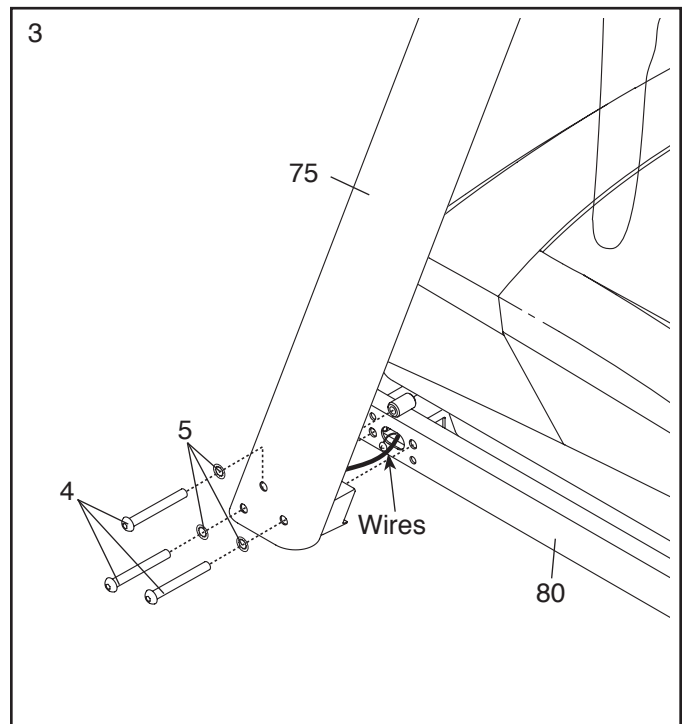

4. Identify the Left and Right Base Covers (73, 74), which are marked "L" and "R." Slide the Left and Right Base Covers onto the Left and Right Uprights (75, 76) as shown.

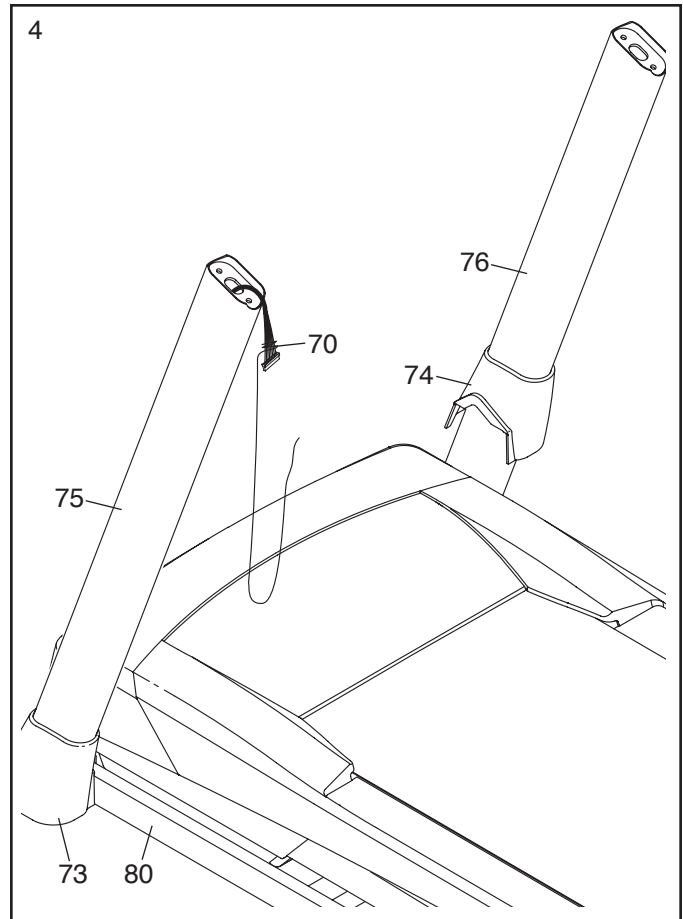

5. Identify the Left Handrail (71), which is marked "Left." If there is a wire in the Left Handrail, remove and discard it.

Hold the Left Handrail (71) near the Left Upright (75). Insert the wire tie on the Upright Wire (70) through the bottom and out of the end of the Left Handrail as shown. Then, pull the Upright Wire through the Left Handrail.

Attach the Left Handrail (71) to the Left Upright (75) with two 3/8" x 3 1/2" Screws (9) and two 3/8" Star Washers (5). **Make sure not to pinch the Upright Wire (70). Start both Screws, but do not tighten them yet.**

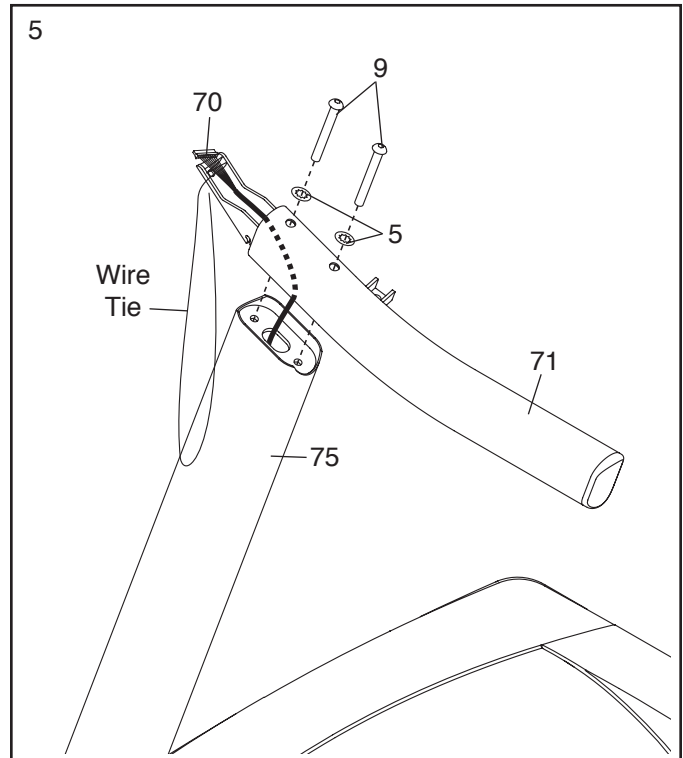

6. Attach the Right Handrail (72) to the Right Upright (76) with two 3/8" x 3 1/2" Screws (9) and two 3/8" Star Washers (5). **Start both Screws, but do not tighten them yet.**

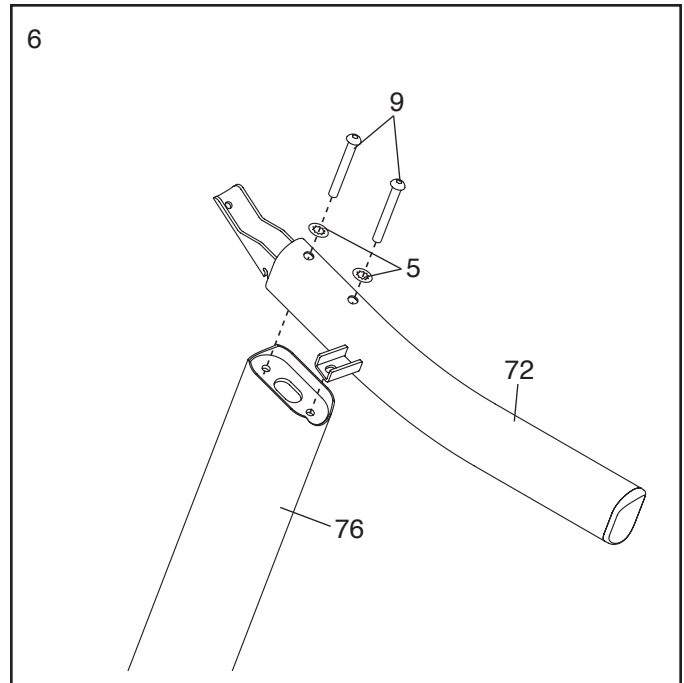

7. Remove the four 1/4" x 1" Screws (10) from the Console Frame (87). **The Screws will be used in step 8.**

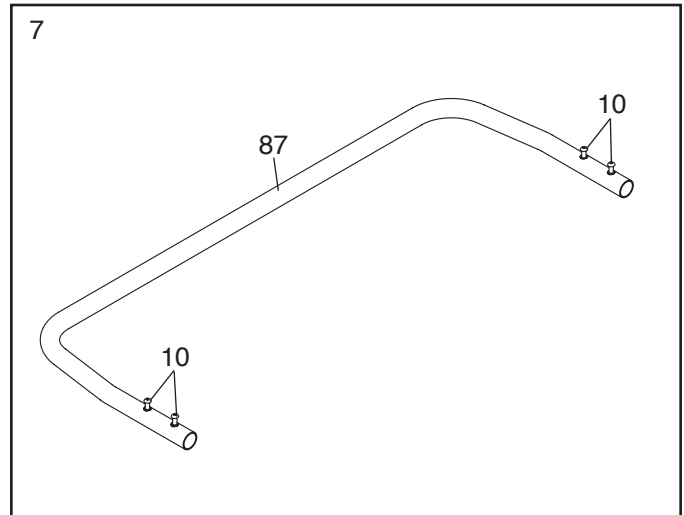

8. Insert the Console Frame (87) into the Handrails (71, 72). Attach the Console Frame with the four 1/4" x 1" Screws (10) that you removed in step 8. **Start all four Screws, and then tighten them.** Be careful not to pinch the Upright Wire (not shown).

Firmly tighten the four 3/8" x 3 1/2" Screws (9).

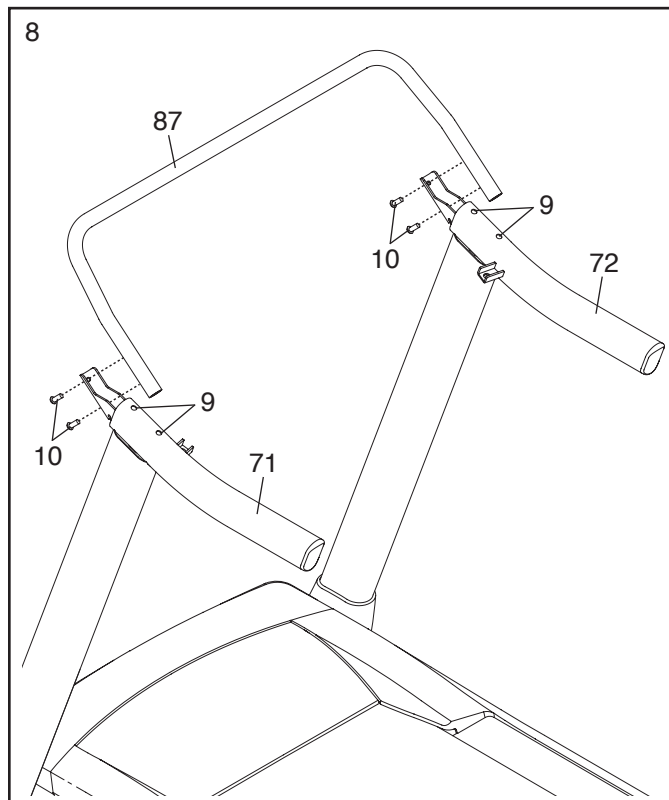

9. With the help of a second person, hold the console assembly near the Left Handrail (71) and the Right Handrail (not shown).

Connect the Upright Wire (70) to the console wire. **See the inset drawing. The connectors should slide together easily and snap into place.** If they do not, turn one connector and try again. **IF YOU DO NOT CONNECT THE CONNECTORS PROPERLY, THE CONSOLE MAY BECOME DAMAGED WHEN YOU TURN ON THE POWER.** Then, remove the wire tie from the Upright Wire.

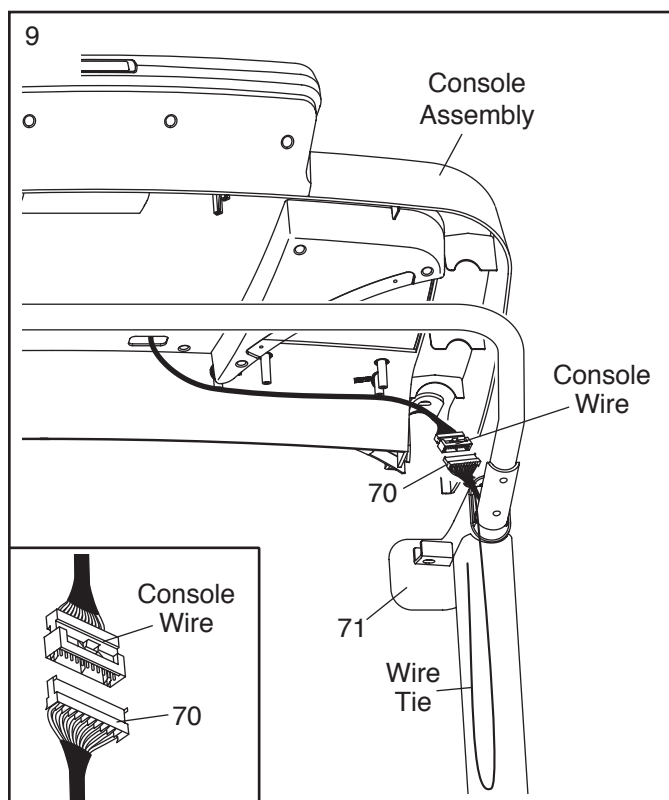

10. Set the console assembly on the Left and Right Handrails (71, 72). **Make sure that no wires are pinched.** Insert the excess Upright Wire (70) into the Left Handrail.

Attach the console assembly to the brackets on the Handrails (71, 72) with two 5/16" x 1" Screws (7) and two 5/16" Star Washers (8). **Start both Screws, and then tighten them.**

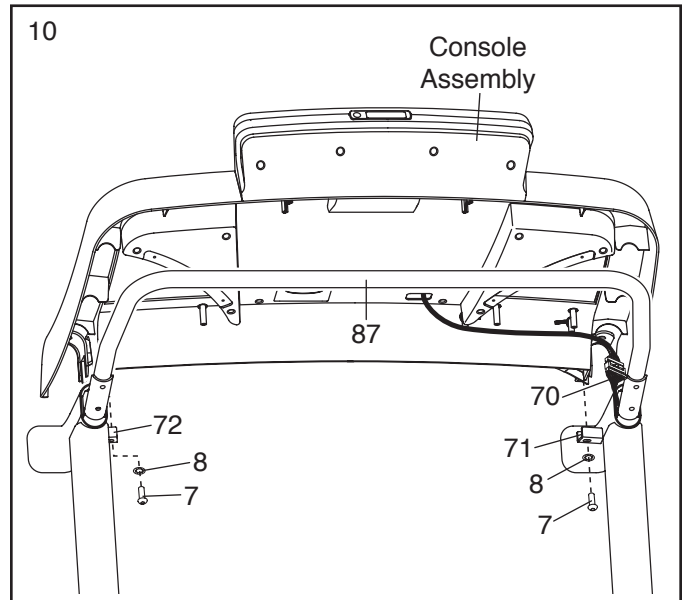

11. Attach the two Console Clamps (96) to the console assembly with four #8 x 3/4" Screws (6).

See step 3. Tighten all six 3/8" x 4" Screws (4).

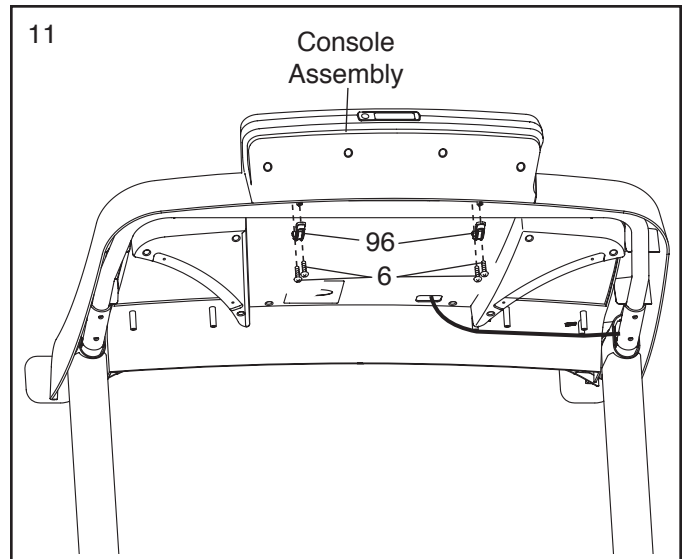

12. Identify the Left and Right Trays (97, 98), which are marked "L" and "R." Orient the Trays as shown and attach each Tray with four #8 x 3/4" Screws. **Start all of the Screws before tightening them. Be careful not to overtighten the Screws.**

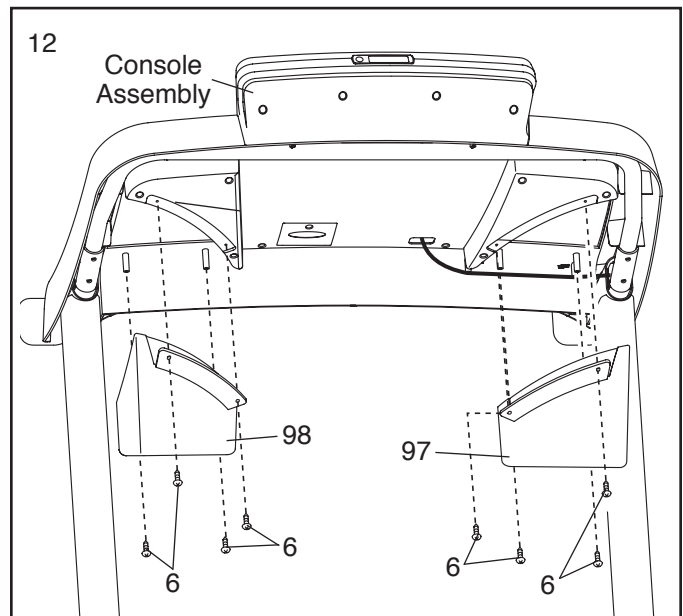

13. Raise the Frame (49) to the position shown.
Have a second person hold the Frame until this step is completed.

Orient the Storage Latch (51) so that the large barrel and the latch knob are oriented as shown.

Attach the lower end of the Storage Latch (51) to the Base (80) with a 3/8" x 2" Bolt (12) and a 3/8" Nut (3).

Attach the upper end of the Storage Latch (51) to the Frame (49) with a 3/8" x 2" Bolt (12) and a 3/8" Nut (3).

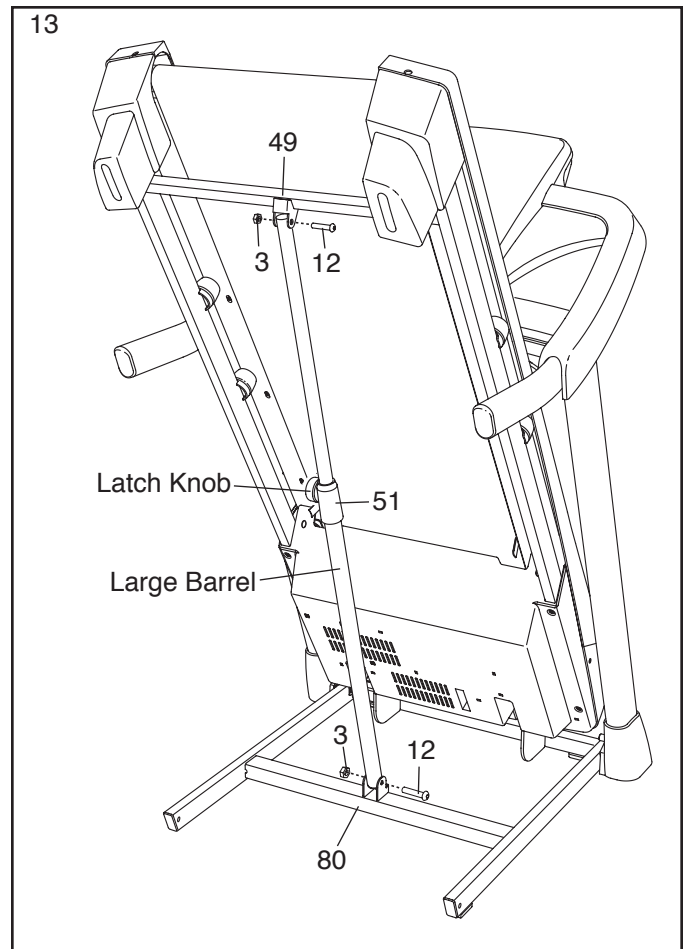

14. Attach a Wheel (81) to the Base (80) with a 3/8" x 2 1/2" Bolt (2) and a 3/8" Nut (3). **Do not over-tighten the Nut; the Wheel must turn freely.**

Attach the other Wheel (81) to the other side of the Base (80) in the same way.

Lower the Frame (not shown) (see HOW TO LOWER THE TREADMILL FOR USE on page 22).

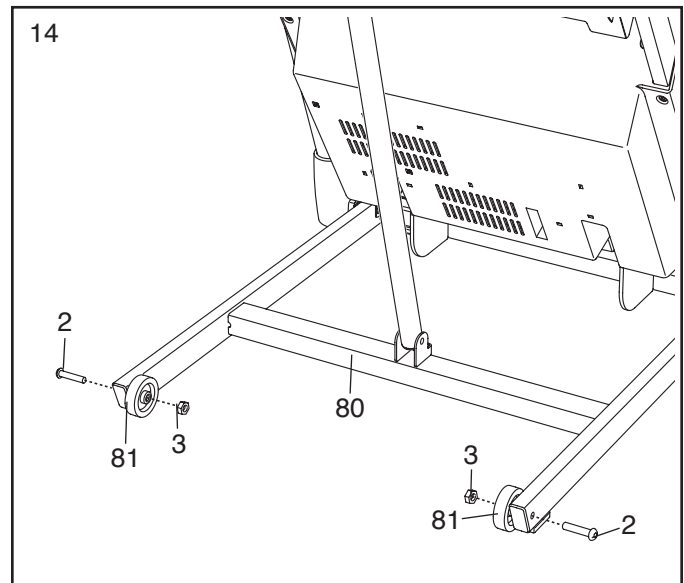

15. **Make sure that all parts are properly tightened before you use the treadmill.** If there are sheets of plastic on the treadmill decals, remove the plastic. To protect the floor or carpet, place a mat under the treadmill. Note: Extra hardware may be included. Keep the included hex key in a secure place; the hex key is used to adjust the walking belt (see pages 24 and 25).

OPERATION AND ADJUSTMENT

HOW TO CONNECT THE POWER CORD

Use a Surge Suppressor

Your treadmill, like other electronic equipment, can be damaged by sudden voltage changes in your home's power. Voltage surges, spikes, and noise interference can result from weather conditions or from other appliances being turned on or off. **To decrease the risk of damaging the treadmill, always use a surge suppressor with the treadmill. To purchase a surge suppressor, see precaution 12 on page 3.**

Use only a surge suppressor that is UL 1449 listed as a transient voltage surge suppressor (TVSS). The surge suppressor must have a UL suppressed voltage rating of 400 volts or less and a minimum surge dissipation of 450 joules. The surge suppressor must also be electrically rated for 120 volts AC and 15 amps. There must be a monitoring light on the surge suppressor to indicate whether it is functioning properly. **Failure to use a properly functioning surge suppressor could result in damage to the control system of the treadmill and serious injury to users.**

Plug in the Power Cord

The treadmill must be grounded. If it should malfunction or break down, grounding provides a path of least resistance for electric current to reduce the risk of electric shock. The treadmill power cord has a plug with a grounding pin (see drawing 1 on this page).

⚠ DANGER: Improper connection of the power cord increases the risk of electric shock. Do not modify the plug—if it will not fit an outlet, have a proper outlet installed by a qualified electrician. If you are unsure whether the treadmill is properly grounded, contact a qualified electrician.

Plug the power cord into a surge suppressor, and plug the surge suppressor into an appropriate outlet that is properly installed and grounded in accordance with all local codes and ordinances. **The outlet must be on a**

nominal 120-volt circuit capable of carrying 15 or more amps. To avoid overloading the circuit, do not plug other electrical devices, except for low-power devices such as cell phone chargers, into the surge suppressor or into an outlet on the same circuit. **IMPORTANT: The treadmill is not compatible with GFCI-equipped outlets and may not be compatible with AFCI-equipped outlets.**

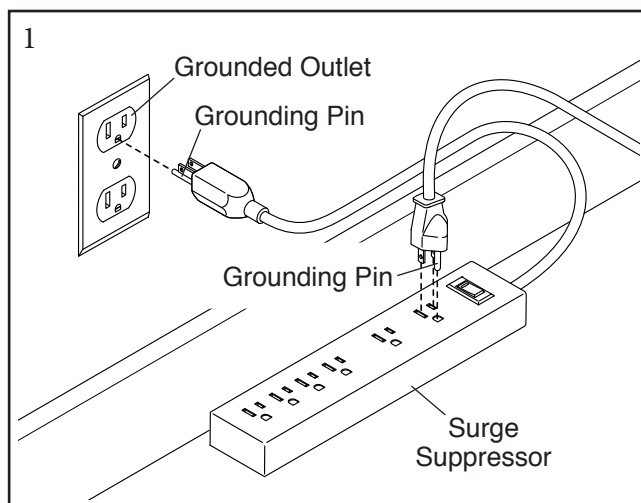

A temporary adapter may be used to connect the surge suppressor to a 2-pole receptacle if a properly grounded outlet is not available.

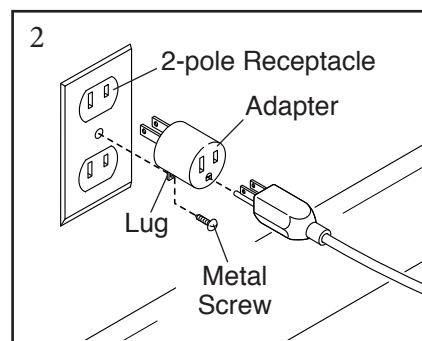

The lug or wire extending from the adapter must be connected with a metal screw to a permanent ground such as a properly grounded outlet box cover. **Some 2-pole receptacle outlet box covers are not grounded. Before using an adapter, contact a qualified electrician to determine whether the outlet box cover is grounded. The temporary adapter should be used only until a properly grounded outlet can be installed by a qualified electrician.**

CONSOLE DIAGRAM

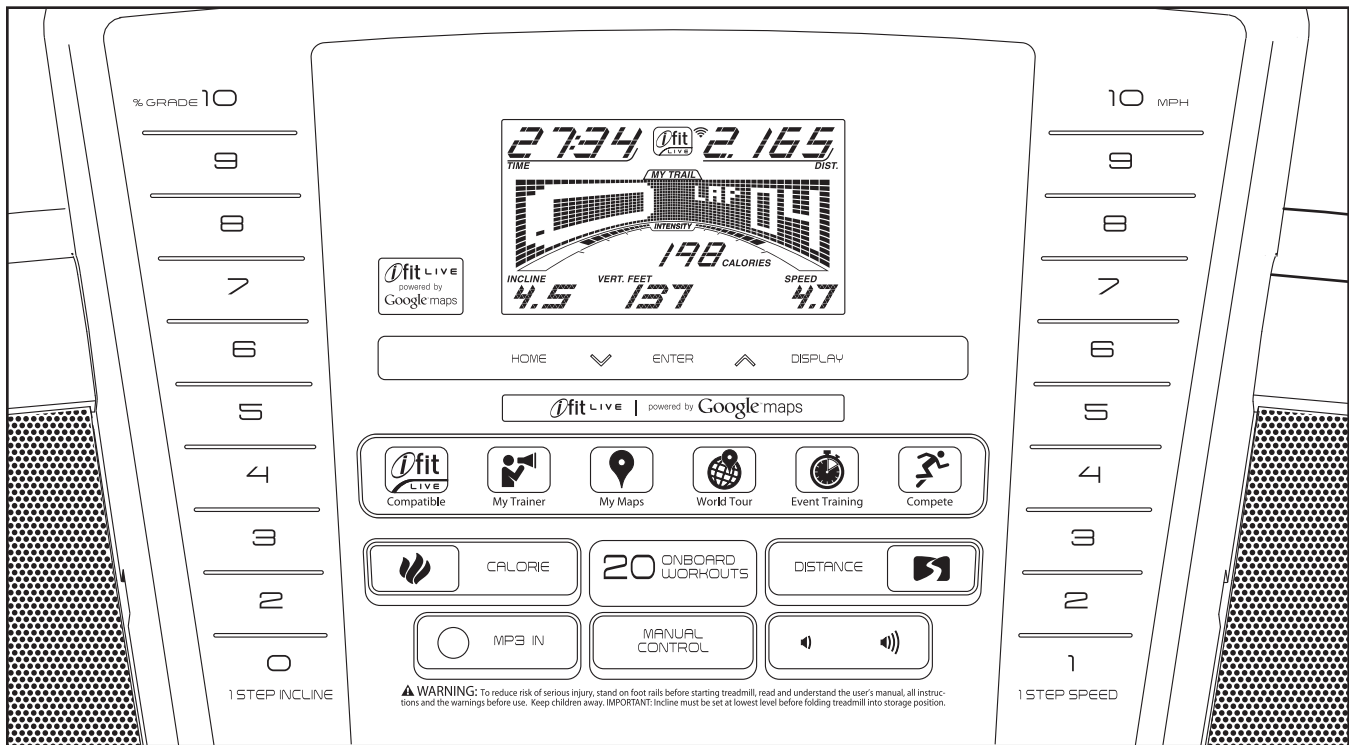

FEATURES OF THE CONSOLE

The treadmill console offers an impressive array of features designed to make your workouts more effective and enjoyable.

When the manual mode of the console is selected, you can change the speed and incline of the treadmill with the touch of a button. As you exercise, the console will display instant exercise feedback. You can even measure your heart rate using the handgrip heart rate monitor.

In addition, the console offers twenty onboard workouts—ten calorie workouts and ten distance workouts. Each workout automatically controls the speed and incline of the treadmill as it guides you through an effective exercise session.

The console also features an iFit Live mode that enables the treadmill to communicate with your wireless network through an optional iFit Live module. With the iFit Live mode, you can download personalized workouts, create your own workouts, track your workout results, race against other runners, and access many other features. **To purchase an iFit Live module at any time, go to www.iFit.com or call the telephone number on the front cover of this manual.**

You can even listen to your favorite workout music or audio books with the console's premium stereo sound system while you get in shape.

To turn on the power, see page 16. **To use the manual mode**, see page 16. **To use the stereo sound system**, see page 18. **To use an onboard workout**, see page 19. **To use an iFit Live workout**, see page 20. **To use the information mode**, see page 21.

IMPORTANT: If there is a sheet of plastic on the console, remove the plastic. To prevent damage to the walking platform, wear clean athletic shoes while using the treadmill. The first time the treadmill is used, observe the alignment of the walking belt, and center the walking belt if necessary (see page 25).

Note: The console can display speed and distance in either miles or kilometers. To find out which unit of measurement is selected or to change the unit of measurement, see THE INFORMATION MODE on page 21. For simplicity, all instructions in this section refer to miles.

HOW TO TURN ON THE POWER

IMPORTANT: If the treadmill has been exposed to cold temperatures, allow it to warm to room temperature before turning on the power. If you do not do this, you may damage the console displays or other electrical components.

Plug in the power cord (see page 14). Next, locate the power switch on the treadmill frame near the power cord. Make sure that the switch is in the reset position.

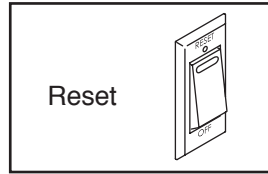

IMPORTANT: The console features a display demo mode, designed to be used if the treadmill is displayed in a store. If the displays light as soon as you plug in the power cord and press the power switch into the reset position, the demo mode is turned on. To turn off the demo mode, hold down the Stop button for a few seconds. If the displays remain lit, see THE INFORMATION MODE on page 21 to turn off the demo mode.

Next, stand on the foot rails of the treadmill. Find the clip attached to the key and slide the clip onto the waistband of your clothes. Then, insert the key into the console.

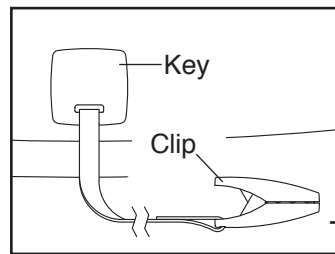

After a moment, the displays will light. **IMPORTANT:** In an emergency, the key can be pulled from the console, causing the walking belt to slow to a stop. Test the clip by carefully taking a few steps backward; if the key is not pulled from the console, adjust the position of the clip.

Note: The first time you insert the key into the console, the incline will automatically rise to the maximum incline level and then return to the minimum incline level.

HOW TO USE THE MANUAL MODE

1. Insert the key into the console.

See HOW TO TURN ON THE POWER at the left.

2. Select the manual mode.

If the manual mode is not selected, press the Manual Control button to select the manual mode.

3. Start the walking belt.

To start the walking belt, press the Start button, the Speed increase button, or one of the numbered Quick Speed buttons.

If you press the Start button or the Speed increase button, the walking belt will begin to move at 1 mph. As you exercise, change the speed of the walking belt as desired by pressing the Speed increase and decrease buttons. Each time you press one of the buttons, the speed setting will change by 0.1 mph; if you hold down the button, the speed setting will change in increments of 0.5 mph. Note: After you press the buttons, it may take a moment for the walking belt to reach the selected speed setting.

If you press one of the numbered Quick Speed buttons, the walking belt will gradually change speed until it reaches the selected speed setting. To select a speed setting that includes a decimal—such as 3.5 mph—press two numbered buttons in succession. For example, to select a speed setting of 3.5 mph, press the 3 button and then immediately press the 5 button.

To stop the walking belt, press the Stop button. The time will begin to flash in the display. To restart the walking belt, press the Start button or the Speed increase button.

4. Change the incline of the treadmill as desired.

To change the incline of the treadmill, press the Incline increase or decrease button or one of the numbered Quick Incline buttons. Each time you press one of the buttons, the treadmill will gradually adjust to the selected incline setting.

5. Follow your progress with the displays.

As you walk or run on the treadmill, the display can show the following workout information:

- The elapsed time
- The distance that you have walked or run
- The workout intensity bar
- The approximate number of calories you have burned
- The incline level of the treadmill
- The number of vertical feet you have climbed
- The speed of the walking belt
- Your heart rate (see step 6 on page 18)
- The matrix

The matrix offers several display tabs. Press the increase and decrease buttons next to the Enter button or press the Display button until the desired tab is shown.

The Incline tab will show a profile of the incline settings of the workout. A new segment will appear at the end of each minute.

The Speed tab will show a profile of the speed settings of the workout.

The My Trail tab will show a track that represents 1/4 mile (400 m). As you exercise, the flashing rectangle will show your progress. The My Trail tab will also show the number of laps you complete.

The Calorie tab will show the approximate amount of calories you have burned. The height of each segment represents the amount of calories burned during that segment. Note: When you select the Calorie tab, the calorie display will show the approximate number of calories burned per hour.

As you exercise, the workout intensity level bar will indicate the approximate intensity level of your exercise.

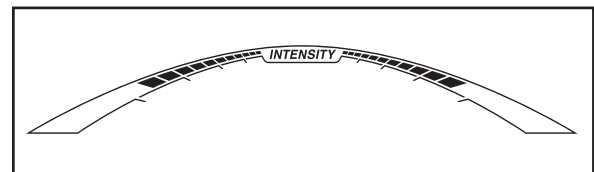

Press the Home button to return to the default menu (see THE INFORMATION MODE on page 21 to set the default menu). If necessary, press the Home button again.

When a wireless iFit Live module is connected, the wireless symbol at the top of the display will show the strength of your wireless signal. Four arcs indicate full signal strength.



To reset the displays, press the Stop button, remove the key, and then reinsert the key.

6. Measure your heart rate if desired.

Before using the heart rate monitor, remove the sheets of plastic from the metal contacts, if necessary. In addition, make sure that your hands are clean.

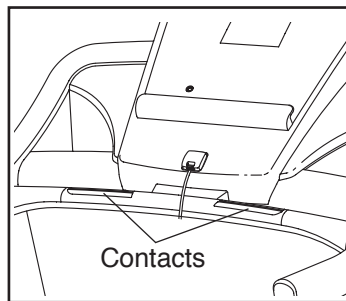

To measure your heart rate, **stand on the foot rails** and hold the metal contacts on the handrails for approximately ten seconds—**avoid moving your hands**. When your pulse is detected, a heart symbol in the calorie display will flash each time your heart beats, one or two dashes will appear, and then your heart rate will be shown. **For the most accurate heart rate reading, continue to hold the contacts for about 15 seconds.**

7. When you are finished exercising, remove the key from the console.

Step onto the foot rails, press the Stop button, and **adjust the incline of the treadmill to the lowest setting. The incline must be at the lowest setting or you may damage the treadmill when you fold it to the storage position.** Next, remove the key from the console and put it in a secure place.

When you are finished using the treadmill, press the power switch into the off position and unplug the power cord. **IMPORTANT: If you do not do this, the treadmill's electrical components may wear prematurely.**

HOW TO USE THE STEREO SOUND SYSTEM

To play music or audio books through the console's stereo speakers, you must connect your MP3 player, CD player, or other personal audio player to the console through the MP3 jack.

Plug one end of your audio wire into the audio jack on the console. Plug the other end into a jack on your MP3 player, CD player, or other personal audio player. **Make sure that the audio wire is fully inserted.**

Next, press the Play button on your MP3 player, CD player, or other personal audio player. Adjust the volume on your personal audio player or press the volume increase and decrease buttons on the console.

If you are using a personal CD player and the CD skips, set the CD player on the floor or another flat surface instead of on the console.

HOW TO USE AN ONBOARD WORKOUT

1. Insert the key into the console.

See HOW TO TURN ON THE POWER on page 16.

2. Select an onboard workout.

To select an onboard workout, press either the Calorie button or the Distance button repeatedly.

When you select an onboard workout, the display will show the duration, the distance, the name, the maximum speed setting, and the maximum incline setting of the workout. In addition, a profile of the speed settings of the workout will appear in the matrix. If you select a calorie workout, the approximate number of calories you will burn will appear in the name of the workout.

3. Start the workout.

Press the Start button or the Speed increase button to start the workout. A moment after you press the button, the treadmill will automatically adjust to the first speed and incline settings of the workout. Hold the handrails and begin walking.

Each workout is divided into segments. One speed setting and one incline setting are programmed for each segment. Note: The same speed setting and/or incline setting may be programmed for consecutive segments.

During the workout, the profiles on the speed and incline tabs will show your progress.

The flashing segment of the profile represents the current segment of the workout. The height of the flashing segment indicates the speed or incline setting for the current segment. At the end of each segment, a series of tones will sound and the next segment of the profile will begin to flash. If a different speed and/or incline setting is programmed for the next segment, the treadmill will automatically adjust to the new speed and/or incline setting.

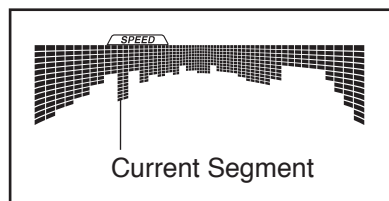

The workout will continue in this way until the last segment of the profile flashes in the display and the last segment ends. The walking belt will then slow to a stop.

Note: The calorie goal is an estimate of the number of calories that you will burn during the workout. The actual number of calories that you burn will depend on your metabolic rate. In addition, if you manually change the speed or incline of the treadmill during the workout, the number of calories you burn will be affected.

If the speed or incline setting is too high or too low at any time during the workout, you can manually override the setting by pressing the Speed or Incline buttons; **however, when the next segment of the workout begins, the treadmill will automatically adjust to the speed and incline settings for the next segment.**

To stop the workout at any time, press the Stop button. The time will begin to flash in the display. To resume the workout, press the Start button or the Speed increase button. The walking belt will begin to move at 1 mph. When the next segment of the workout begins, the treadmill will automatically adjust to the speed and incline settings for the next segment.

4. Follow your progress with the displays.

See step 5 on page 17. The display will show the time remaining in the workout instead of the elapsed time.

5. Measure your heart rate if desired.

See step 6 on page 18.

6. When you are finished exercising, remove the key from the console.

See step 7 on page 18.

HOW TO USE AN IFIT LIVE WORKOUT

Note: To use an iFit Live workout, you must have an optional iFit Live module. **To purchase an iFit Live module at any time, go to www.iFit.com or call the telephone number on the front cover of this manual.** You must also have access to a computer with a USB port and an internet connection. In addition, you must have access to a wireless network including an 802.11b router with SSID broadcast enabled (hidden networks are not supported). An iFit.com membership is also required.

1. Insert the key into the console.

See HOW TO TURN ON THE POWER on page 16.

2. Insert the iFit Live module into the console.

To insert the iFit Live module, see the instructions included with the iFit Live module.

IMPORTANT: To satisfy exposure compliance requirements, the antenna and transmitter in the iFit Live module must be at least 8 in. (20 cm) from all persons and must not be near or connected to any other antenna or transmitter.

3. Select a user.

If more than one user is registered, you can switch users in the iFit Live main screen. Press the increase and decrease buttons next to the Enter button to select a user.

4. Select an iFit Live workout.

To select an iFit Live workout, press one of the iFit Live buttons. Before some workouts will download, you must add them to your schedule on www.iFit.com.

Press the iFit Live button to download the next workout in your schedule. Press the My Trainer button, the My Maps button, the World Tour button, or the Event Training button to download the next workout of that type in your schedule. Press the Compete button to compete in a race that you have previously scheduled. **For more information about the iFit Live workouts, please see www.iFit.com.**

When you select an iFit Live workout, the display will show the duration of the workout, the distance you will walk or run, and the approximate number of

calories you will burn. The display may also show the name of the workout. If you select a competition workout, the display will count down to the beginning of the race.

Note: Each iFit Live button can also run two demo workouts. To use the demo workouts, remove the iFit Live module from the console and press one of the iFit Live buttons.

5. Start the workout.

See step 3 on page 19.

During some workouts, the voice of a personal trainer will guide you through your workout. You can select an audio setting for your personal trainer (see THE INFORMATION MODE on page 21).

To stop the workout at any time, press the Stop button. The time will begin to flash in the display. To resume the workout, press the Start button or the Speed increase button. The walking belt will begin to move at the speed setting for the first segment of the workout. When the next segment of the workout begins, the treadmill will automatically adjust to the speed and incline settings for the next segment.

6. Follow your progress with the displays.

See step 5 on page 17.

The My Trail tab will show a map of the trail you are walking or running or it will show a track and the number of laps you complete.

During a competition workout, the Compete tab will show your progress in the race. As you race, the top line in the matrix will show how much of the race you have completed. The other lines will show your top four competitors. The end of the matrix represents the end of the race.

7. Measure your heart rate if desired.

See step 6 on page 18.

8. When you are finished exercising, remove the key from the console.

See step 7 on page 18.

For more information about the iFit Live mode, go to www.iFit.com.

THE INFORMATION MODE

The console features an information mode that keeps track of treadmill information and allows you to personalize console settings.

To select the information mode, hold down the Stop button while inserting the key into the console and then release the Stop button. When the information mode is selected, the following information will be shown:

The time display will show the total number of hours the treadmill has been used.

The distance display will show the total number of miles (or kilometers) that the walking belt has moved.

The lower section of the display will show the status of an iFit Live module. If an iFit Live module is connected, the display will show the words WIFI MODULE. If a USB module is connected, the display will show the words USB/SD MODULE. If no module is connected, the display will show the words NO IFIT MODULE.

While the information mode is selected, the matrix will display several optional screens. Press the decrease button next to the Enter button to select each of the following screens:

1. **UNITS:** To change the unit of measurement, press the Enter button. To view distance in miles, select ENGLISH. To view distance in kilometers, select METRIC.
2. **DEMO:** The console features a display demo mode, designed to be used if the treadmill is displayed in a store. While the demo mode is turned on, the console will function normally when you plug in the power cord, press the power switch into the reset position, and insert the key into the console. However, when you remove the key, the displays will remain lit, although the buttons will not function. If the demo mode is turned on, the word ON will appear in the matrix. To turn on or turn off the demo mode, press the Enter button.

3. **CONTRAST LVL:** Press the Incline increase and decrease buttons to adjust the contrast level of the display.

If a module is connected, you may also select the following screen:

4. **TRAINER VOICE:** To turn on or turn off the voice of the personal trainer, press the Enter button.

If an iFit Live module is connected, you may also select the following screens:

5. **DEFAULT MENU:** The default menu will appear when you insert the key into the console or when you press the Home button. Press the Enter button repeatedly to select the manual main screen or the iFit Live screen as the default menu.
6. **CHECK WIFI STATUS:** Press the Enter button to check the status of your iFit Live module. The lower display will show the software version number, the network SSID, the network encryption type, the connection status, the wireless signal strength, the IP address of the module, the number of registered users and their names, the results of the DNS lookup, and the status of the iFit Live server.
7. **SEND/RECEIVE DATA:** To send and receive workouts, workout logs, and updates, press the Enter button. When the process is finished, the words TRANSFERS DONE will appear in the display.

To exit the information mode, remove the key from the console.

HOW TO FOLD AND MOVE THE TREADMILL

HOW TO FOLD THE TREADMILL

To avoid damaging the treadmill, adjust the incline to the lowest position before you fold the treadmill. Then, remove the key and unplug the power cord. **CAUTION:** You must be able to safely lift 45 lbs. (20 kg) to raise, lower, or move the treadmill.

1. Hold the metal frame firmly in the location shown by the arrow below. **CAUTION: Do not hold the frame by the plastic foot rails. Bend your legs and keep your back straight.**

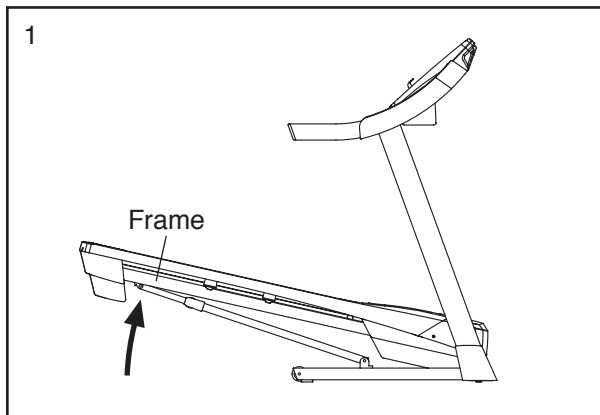

2. Raise the frame until the latch knob locks in the storage position. **CAUTION: Make sure that the latch knob locks.**

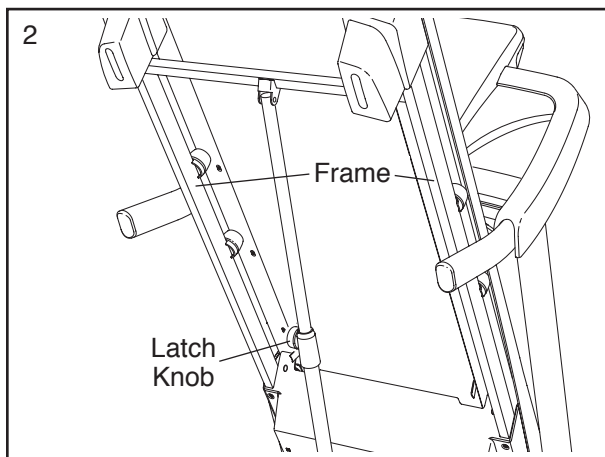

To protect the floor or carpet, place a mat under the treadmill. Keep the treadmill out of direct sunlight. Do not leave the treadmill in the storage position in temperatures above 85° F (30° C).

HOW TO MOVE THE TREADMILL

Before moving the treadmill, fold it as described at the left. **CAUTION: Make sure that the latch knob is locked in the storage position. Moving the treadmill may require two people.**

1. Hold the frame and one of the handrails, and place one foot against a wheel.

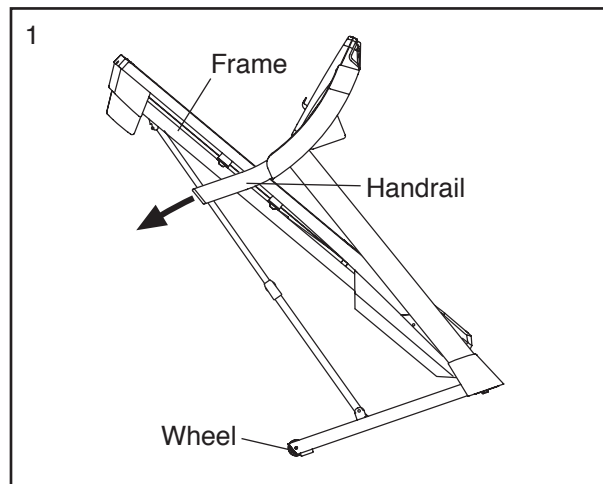

2. Pull back on the handrail until the treadmill will roll on the wheels, and carefully move it to the desired location. **CAUTION: Do not move the treadmill without tipping it back, do not pull on the frame, and do not move the treadmill over an uneven surface.**
3. Place one foot against a wheel, and carefully lower the treadmill.

HOW TO LOWER THE TREADMILL FOR USE

1. **See drawing 2.** Hold the upper end of the treadmill with your right hand. Then, pull the latch knob to the left and hold it. **IMPORTANT: Do not turn the latch knob.** If necessary, push the frame forward slightly. Pivot the frame downward a few inches, and release the latch knob.
2. **See drawing 1 at the left.** Hold the metal frame firmly with both hands, and lower it to the floor. **CAUTION: Do not hold the frame by the plastic foot rails, and do not drop the frame. Bend your legs and keep your back straight.**

TROUBLESHOOTING

Most treadmill problems can be solved by following the simple steps below. Find the symptom that applies, and follow the steps listed. If further assistance is needed, see the front cover of this manual.

SYMPTOM: The power does not turn on

- Make sure that the power cord is plugged into a surge suppressor and that the surge suppressor is plugged into a properly-grounded outlet (see page 14). Use only a single-outlet surge suppressor that meets all of the specifications described on page 14. **IMPORTANT: The treadmill is not compatible with GFCI-equipped outlets and may not be compatible with AFCI-equipped outlets.**
- After the power cord has been plugged in, make sure that the key is inserted into the console.
- Check the power switch located on the treadmill frame near the power cord. If the switch protrudes as shown, the switch has tripped. To reset the power switch, wait for five minutes and then press the switch back in.

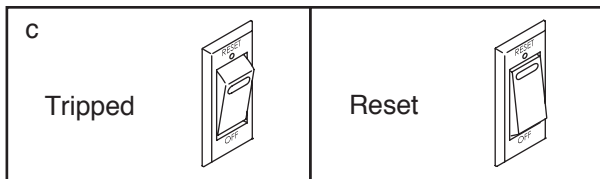

SYMPTOM: The power turns off during use

- Check the power switch (see the drawing above). If the switch has tripped, wait for five minutes and then press the switch back in.
- Make sure that the power cord is plugged in. If the power cord is plugged in, unplug it, wait for five minutes, and then plug it back in.

- Remove the key from the console, and then reinsert it.
- If the treadmill still will not run, please see the front cover of this manual.

SYMPTOM: The console displays remain lit when you remove the key from the console

- The console features a display demo mode, designed to be used if the treadmill is displayed in a store. If the displays remain lit when you remove the key, the demo mode is turned on. To turn off the demo mode, hold down the Stop button for a few seconds. If the displays are still lit, see THE INFORMATION MODE on page 21 to turn off the demo mode.

SYMPTOM: The displays of the console do not function properly

- Remove the key from the console and **UNPLUG THE POWER CORD.**

Remove the five #8 x 3/4" Screws (6). Carefully slide the Motor Hood (57) off.

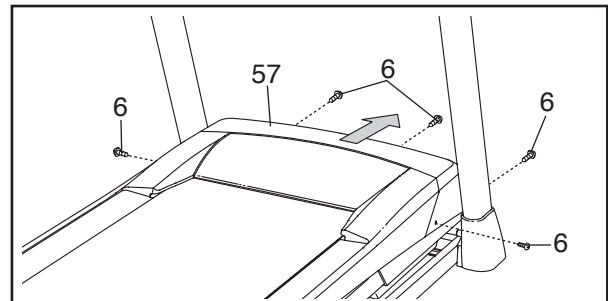

Locate the Reed Switch (95) and the Magnet (44) on the left side of the Pulley (43). Turn the Pulley until the Magnet is aligned with the Reed Switch. **Make sure that the gap between the Magnet and the Reed Switch is about 1/8 in. (3 mm).** If necessary, loosen the #8 x 3/4" Truss Head Screw (19), move the Reed Switch slightly, and then re-tighten the Screw. Reattach the Motor Hood (not shown) with the five #8 x 3/4" Screws (not shown) and run the treadmill for a few minutes to check for a correct speed reading.

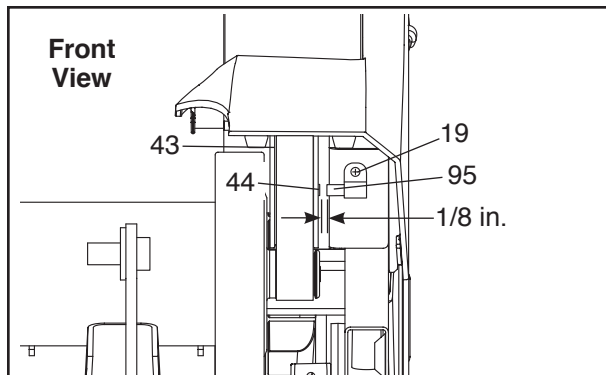

SYMPTOM: The incline of the treadmill does not change correctly

- a. With the key in the console, press one of the Incline buttons. **While the incline is changing, remove the key.** After a few seconds, reinsert the key. The treadmill will automatically rise to the maximum incline level and then return to the minimum level. This will recalibrate the incline system.

SYMPTOM: The walking belt slows when walked on

- a. Use only a single-outlet surge suppressor that meets all of the specifications described on page 14.

- b. If the walking belt is overtightened, treadmill performance may decrease and the walking belt may become damaged. Remove the key and **UNPLUG THE POWER CORD.** Using the hex key, turn both idler roller screws counterclockwise, 1/4 of a turn. When the walking belt is properly tightened, you should be able to lift each edge of the walking belt 2 to 3 in. (5 to 7 cm) off the walking platform. Be careful to keep the walking belt centered. Then, plug in the power cord, insert the key, and run the treadmill for a few minutes. Repeat until the walking belt is properly tightened.

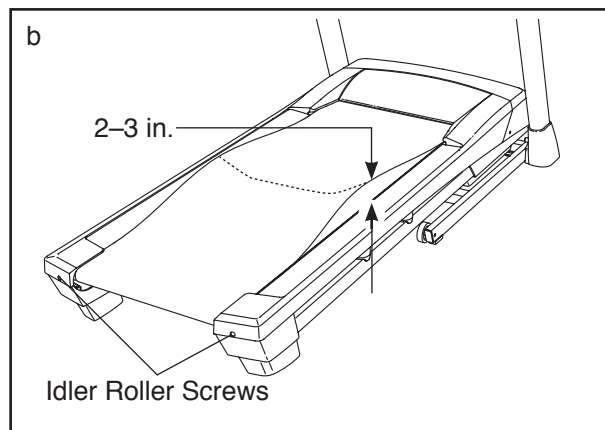

- c. Your treadmill features a walking belt coated with high-performance lubricant. **IMPORTANT: Never apply silicone spray or other substances to the walking belt or the walking platform unless instructed to do so by an authorized service representative. Such substances may deteriorate the walking belt and cause excessive wear.** If you suspect that the walking belt needs more lubricant, see the front cover of this manual.
- d. If the walking belt still slows when walked on, see the front cover of this manual.

SYMPTOM: The walking belt is off-center or slips when walked on

- a. **If the walking belt is off-center**, first remove the key and **UNPLUG THE POWER CORD**. **If the walking belt has shifted to the left**, use the hex key to turn the left idler roller screw clockwise 1/2 of a turn; **if the walking belt has shifted to the right**, turn the left idler roller screw counterclockwise 1/2 of a turn. Be careful not to overtighten the walking belt. Then, plug in the power cord, insert the key, and run the treadmill for a few minutes. Repeat until the walking belt is centered.

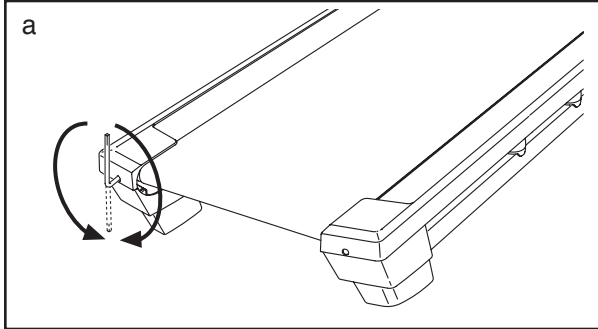

- b. **If the walking belt slips when walked on**, first remove the key and **UNPLUG THE POWER CORD**. Using the hex key, turn both idler roller screws clockwise, 1/4 of a turn. When the walking belt is correctly tightened, you should be able to lift each edge of the walking belt 2 to 3 in. (5 to 7 cm) off the walking platform. Be careful to keep the walking belt centered. Then, plug in the power cord, insert the key, and carefully walk on the treadmill for a few minutes. Repeat until the walking belt is properly tightened.

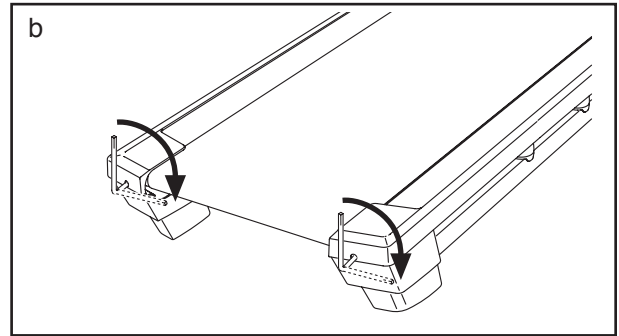

EXERCISE GUIDELINES

⚠️ WARNING: Before beginning this or any exercise program, consult your physician. This is especially important for persons over age 35 or persons with pre-existing health problems.

The heart rate monitor is not a medical device. Various factors may affect the accuracy of heart rate readings. The heart rate monitor is intended only as an exercise aid in determining heart rate trends in general.

These guidelines will help you to plan your exercise program. For detailed exercise information, obtain a reputable book or consult your physician. Remember, proper nutrition and adequate rest are essential for successful results.

EXERCISE INTENSITY

Whether your goal is to burn fat or to strengthen your cardiovascular system, exercising at the proper intensity is the key to achieving results. You can use your heart rate as a guide to find the proper intensity level. The chart below shows recommended heart rates for fat burning and aerobic exercise.

165	155	145	140	130	125	115	♥♥
145	138	130	125	118	110	103	♥
125	120	115	110	105	95	90	♥
<hr/>							
20	30	40	50	60	70	80	

To find the proper intensity level, find your age at the bottom of the chart (ages are rounded off to the nearest ten years). The three numbers listed above your age define your "training zone." The lowest number is the heart rate for fat burning, the middle number is the heart rate for maximum fat burning, and the highest number is the heart rate for aerobic exercise.

Burning Fat—To burn fat effectively, you must exercise at a low intensity level for a sustained period of time. During the first few minutes of exercise, your body uses carbohydrate calories for energy. Only after the first few minutes of exercise does your body begin to use stored fat calories for energy. If your goal is to burn fat, adjust the intensity of your exercise until your heart rate is near the lowest number in your training zone. For maximum fat burning, exercise with your heart rate near the middle number in your training zone.

Aerobic Exercise—If your goal is to strengthen your cardiovascular system, you must perform aerobic exercise, which is activity that requires large amounts of oxygen for prolonged periods of time. For aerobic exercise, adjust the intensity of your exercise until your heart rate is near the highest number in your training zone.

WORKOUT GUIDELINES

Warming Up—Start with 5 to 10 minutes of stretching and light exercise. A warm-up increases your body temperature, heart rate, and circulation in preparation for exercise.

Training Zone Exercise—Exercise for 20 to 30 minutes with your heart rate in your training zone. (During the first few weeks of your exercise program, do not keep your heart rate in your training zone for longer than 20 minutes.) Breathe regularly and deeply as you exercise—never hold your breath.

Cooling Down—Finish with 5 to 10 minutes of stretching. Stretching increases the flexibility of your muscles and helps to prevent post-exercise problems.

EXERCISE FREQUENCY

To maintain or improve your condition, complete three workouts each week, with at least one day of rest between workouts. After a few months of regular exercise, you may complete up to five workouts each week, if desired. Remember, the key to success is to make exercise a regular and enjoyable part of your everyday life.

PART LIST

Model No. NTL61011.1 R0312A

Key No.	Qty.	Description	Key No.	Qty.	Description
1	4	#8 x 1/2" Ground Screw	53	1	Left Rear Foot
2	2	3/8" x 2 1/2" Bolt	54	1	#8 x 1/2" Ground Screw
3	4	3/8" Nut	55	4	#8 x 1/2" Controller Screw
4	6	3/8" x 4" Screw	56	1	Idler Roller
5	10	3/8" Star Washer	57	1	Motor Hood
6	46	#8 x 3/4" Screw	58	2	Incline Frame Spacer
7	2	5/16" x 1" Screw	59	1	Incline Frame
8	2	5/16" Star Washer	60	1	Incline Motor
9	4	3/8" x 3 1/2" Screw	61	1	Controller Ground Wire
10	4	1/4" x 1" Screw	62	1	Controller
11	10	5/16" x 1" Flat Head Screw	63	3	Wire Tie
12	2	3/8" x 2" Bolt	64	1	Belly Pan Plate
13	2	Speaker	65	1	Power Switch
14	2	1/4" x 2 1/2" Screw	66	1	Power Cord
15	2	3/8" x 1 3/8" Bolt	67	2	Grommet
16	2	1/2" x 2 1/4" Bolt	68	1	Belly Pan
17	2	1/2" Nut	69	2	Upright Cap
18	3	Hood Clip	70	1	Upright Wire
19	21	#8 x 3/4" Truss Head Screw	71	1	Left Handrail
20	2	3/8" x 1 1/2" Bolt	72	1	Right Handrail
21	4	3/8" Locknut	73	1	Left Base Cover
22	2	Incline Motor Spacer	74	1	Right Base Cover
23	2	1/4" x 3/8" Screw	75	1	Left Upright
24	4	Belt Guide Screw	76	1	Right Upright
25	2	5/16" x 1 1/4" Bolt	77	4	Base Cap
26	2	5/16" Flange Nut	78	2	Caution Decal
27	2	5/16" x 1 3/4" Bolt	79	4	Base Pad
28	2	5/16" Washer	80	1	Base
29	2	5/16" Nut	81	2	Wheel
30	1	1/4" Fender Washer	82	1	Key/Clip
31	1	Pulse Crossbar	83	1	Console Base
32	1	1/4" x 1 3/4" Screw	84	1	Module Housing
33	8	#8 x 1" Tek Screw	85	0	Not used
34	1	Hex Key	86	1	Console
35	1	5/32" Hex Key	87	1	Console Frame
36	4	Platform Cushion	88	1	Access Door
37	1	Left Foot Rail	89	1	Console Ground Wire
38	1	Latch Warning Decal	90	1	Console Back
39	1	Walking Platform	91	2	Console Wire Tie
40	1	Walking Belt	92	1	Base Ground Wire
41	2	Belt Guide	93	1	Left Speaker Grill
42	2	Rubber Spacer	94	4	#8 x 1" Screw
43	1	Drive Roller/Pulley	95	1	Reed Switch
44	1	Magnet	96	2	Console Clamp
45	1	Reed Switch Clamp	97	1	Left Tray
46	1	Drive Motor Belt	98	1	Right Tray
47	1	Drive Motor	99	1	Right Speaker Grill
48	2	Frame Spacer	100	2	Base Pad Spacer
49	1	Frame	101	1	Left Speaker Cover
50	1	Right Foot Rail	102	1	Right Speaker Cover
51	1	Storage Latch	*	-	User's Manual
52	1	Right Rear Foot			

Note: Specifications are subject to change without notice. For information about ordering replacement parts, see the back cover of this manual. *These parts are not illustrated.

EXPLODED DRAWING A

Model No. NTL61011.1 R0312A

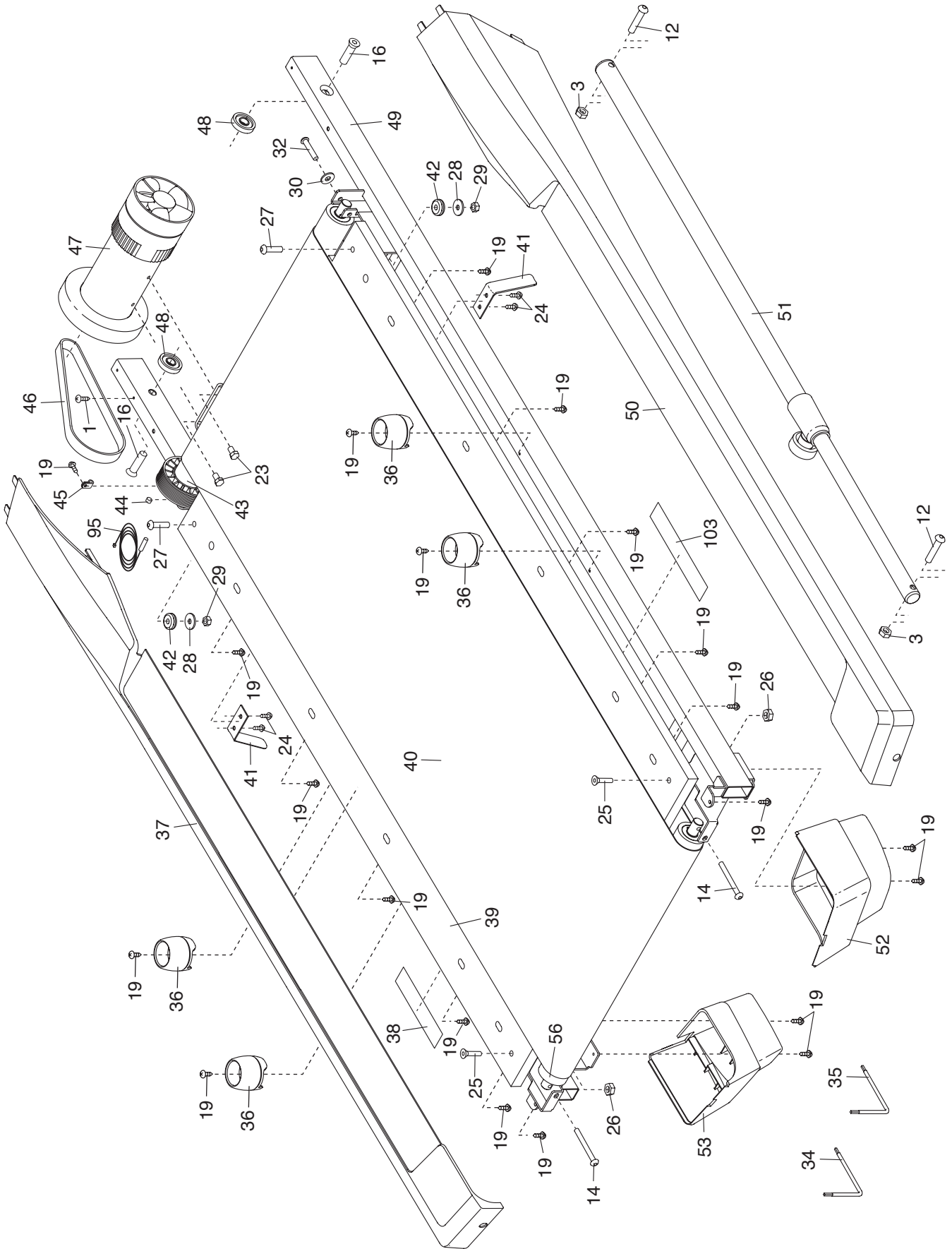

EXPLODED DRAWING B

Model No. NTL61011.1 R0312A

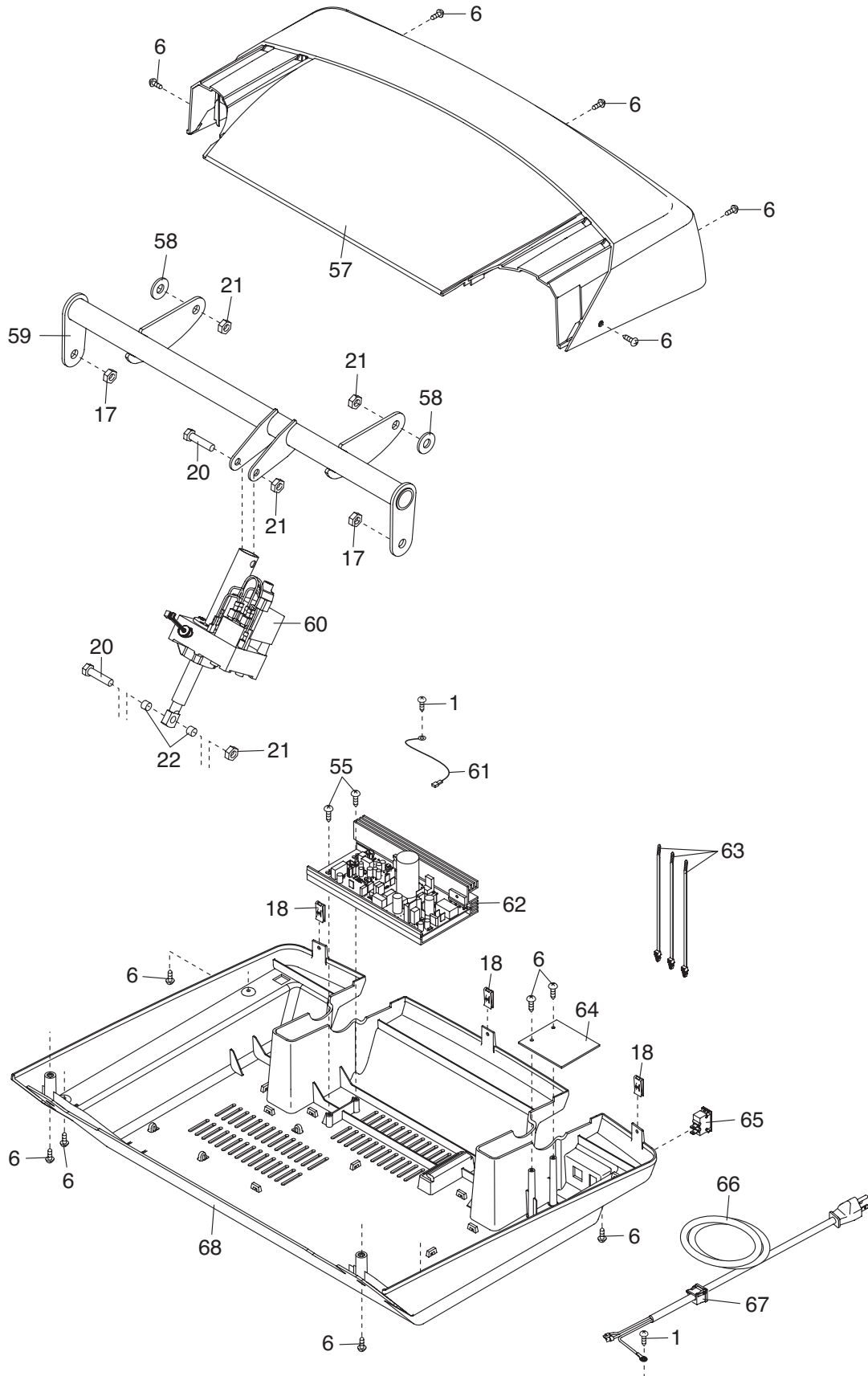

EXPLODED DRAWING C

Model No. NTL61011.1 R0312A

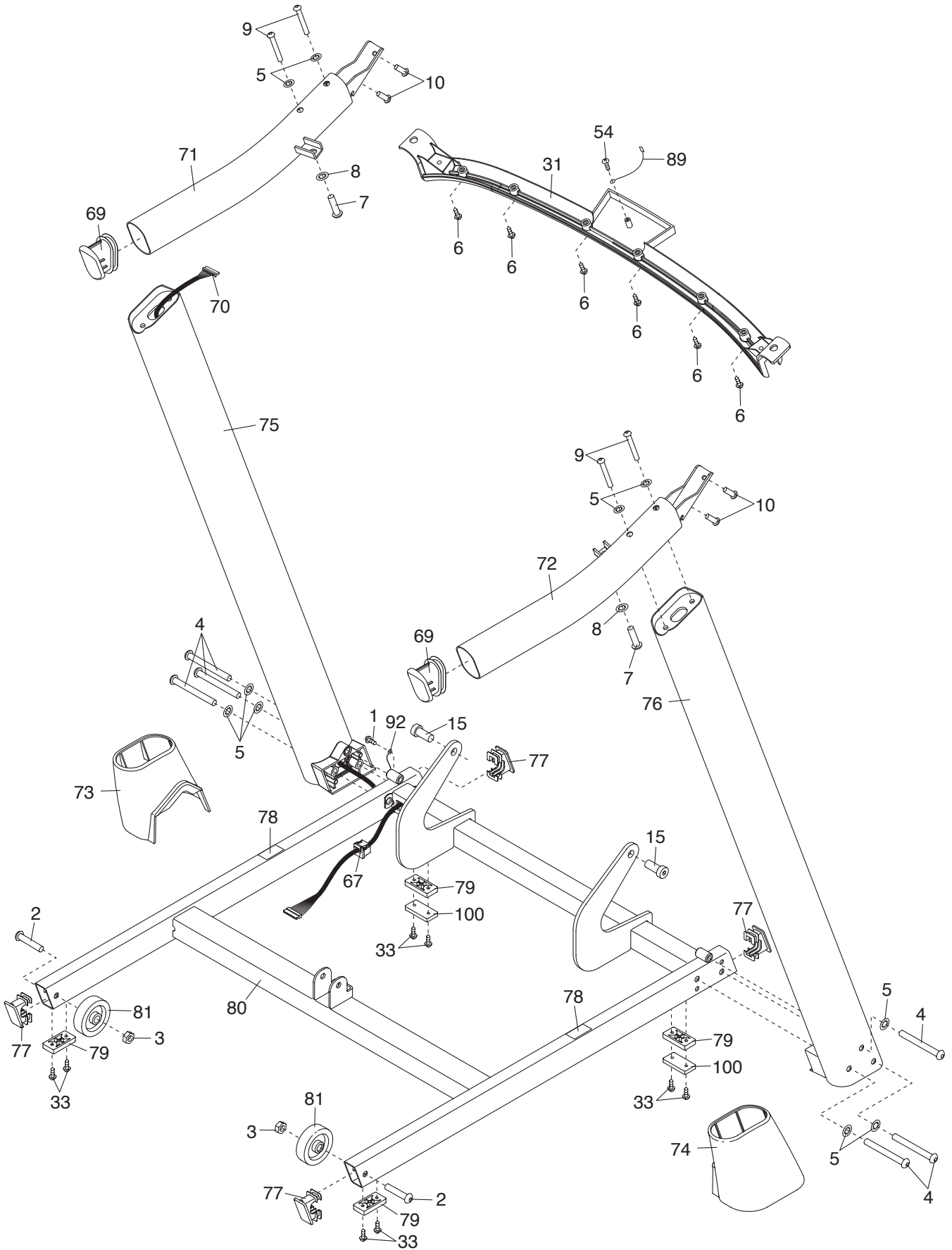

ORDERING REPLACEMENT PARTS

To order replacement parts, please see the front cover of this manual. To help us assist you, be prepared to provide the following information when contacting us:

- the model number and serial number of the product (see the front cover of this manual)
- the name of the product (see the front cover of this manual)
- the key number and description of the replacement part(s) (see the PART LIST and the EXPLODED DRAWING near the end of this manual)

LIMITED WARRANTY

IMPORTANT: You must register this product within 30 days of the purchase date to avoid added fees for service needed under warranty. Go to www.nordictrackservice.com/registration.

ICON Health & Fitness, Inc. (ICON) warrants this product to be free from defects in workmanship and material, under normal use and service conditions. The frame is warranted for a lifetime. The drive motor is warranted for twenty-five (25) years from the date of purchase. Parts and labor are warranted for one (1) year from the date of purchase.

This warranty extends only to the original purchaser (customer). ICON's obligation under this warranty is limited to repairing or replacing, at ICON's option, the product through one of its authorized service centers. All repairs for which warranty claims are made must be preauthorized by ICON. If the product is shipped to a service center, freight charges to and from the service center will be the customer's responsibility. If replacement parts are shipped while the product is under warranty, the customer will be responsible for a minimal handling charge. For in-home service, the customer will be responsible for a minimal trip charge. This warranty does not extend to freight damage to the product. This warranty will automatically be voided if the product is used as a store display model, if the product is purchased or transported outside the USA, if all instructions in this manual are not followed, if the product is abused or improperly or abnormally used, or if the product is used for commercial or rental purposes. No other warranty beyond that specifically set forth above is authorized by ICON.

ICON is not responsible or liable for indirect, special, or consequential damages arising out of or in connection with the use or performance of the product; damages with respect to any economic loss, loss of property, loss of revenues or profits, loss of enjoyment or use, or costs of removal or installation; or other consequential damages of any kind. Some states do not allow the exclusion or limitation of incidental or consequential damages. Accordingly, the above limitation may not apply to the customer.

The warranty extended hereunder is in lieu of any and all other warranties, and any implied warranties of merchantability or fitness for a particular purpose are limited in their scope and duration to the terms set forth herein. Some states do not allow limitations on how long an implied warranty lasts. Accordingly, the above limitation may not apply to the customer.

This warranty provides specific legal rights; the customer may have other rights that vary from state to state.

ICON Health & Fitness, Inc., 1500 S. 1000 W., Logan, UT 84321-9813