

PRO-FORM[®]

XP 185 U

Model No. 831.21741.0

Serial No. _____

Write the serial number in the space above for reference.

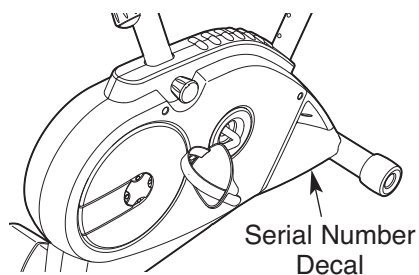

- Assembly
- Operation
- Maintenance
- Part List and Drawing

Sears, Roebuck and Co.
Hoffman Estates, IL 60179

CAUTION

Read all precautions and instructions in this manual before using this equipment. Keep this manual for future reference.

BIKE EXERCISER

User's Manual

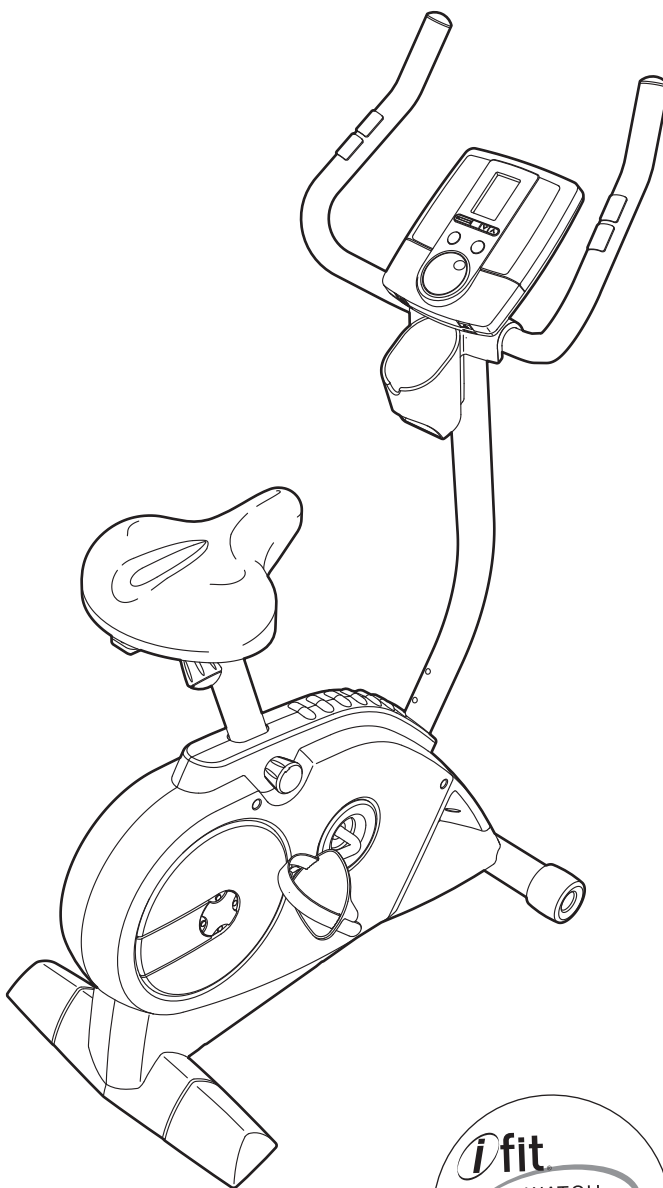
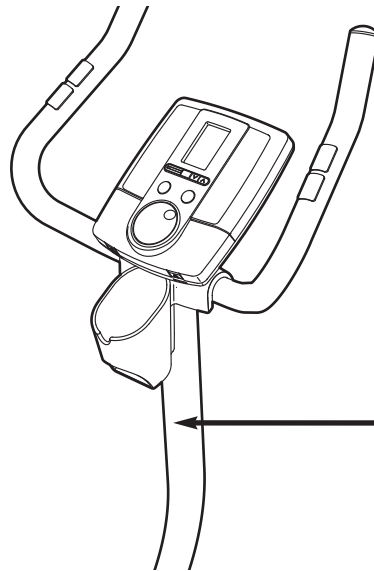

TABLE OF CONTENTS

WARNING DECAL PLACEMENT2
IMPORTANT PRECAUTIONS3
BEFORE YOU BEGIN4
ASSEMBLY5
HOW TO OPERATE THE EXERCISE BIKE11
MAINTENANCE AND TROUBLESHOOTING17
EXERCISE GUIDELINES18
PART LIST22
EXPLODED DRAWING23
ORDERING REPLACEMENT PARTSBack Cover
90 DAY FULL WARRANTYBack Cover

WARNING DECAL PLACEMENT

The warning decal shown here has been applied in the location shown. **If the decal is missing or illegible, call 1-888-533-1333 and request a free replacement decal. Apply the decal in the location shown.** Note: The decal may not be shown at actual size.



⚠ WARNING

- Misuse of this machine may result in serious injury.
- Read user's manual prior to use and follow all warnings and instructions.
- Do not allow children on or around machine.
- Pedals continue to spin when you stop pedaling.
- Spinning pedals can cause injury.
- Reduce pedal speed in a controlled manner.
- User weight must not exceed 250 pounds.
- Replace label if damaged, illegible, or removed.



IMPORTANT PRECAUTIONS

⚠ WARNING: To reduce the risk of serious injury, read all important precautions and instructions in this manual and all warnings on your exercise bike before using your exercise bike. Sears assumes no responsibility for personal injury or property damage sustained by or through the use of this product.

1. Before beginning any exercise program, consult your physician. This is especially important for persons over age 35 or persons with pre-existing health problems.
2. Use the exercise bike only as described in this manual.
3. It is the responsibility of the owner to ensure that all users of the exercise bike are adequately informed of all precautions.
4. The exercise bike is intended for home use only. Do not use the exercise bike in a commercial, rental, or institutional setting.
5. Keep the exercise bike indoors, away from moisture and dust. Do not put the exercise bike in a garage or covered patio, or near water.
6. Place the exercise bike on a level surface with at least 2 ft. (0.6 m) of clearance around the exercise bike. To protect the floor or carpet from damage, place a mat under the exercise bike.
7. Inspect and properly tighten all parts regularly. Replace any worn parts immediately.
8. Keep children under age 12 and pets away from the exercise bike at all times.
9. Wear appropriate clothes while exercising; do not wear loose clothes that could become caught on the exercise bike. Always wear athletic shoes for foot protection.
10. The exercise bike should not be used by persons weighing more than 250 lbs. (113 kg).
11. The pulse sensor is not a medical device. Various factors, including the user's movement, may affect the accuracy of heart rate readings. The pulse sensor is intended only as an exercise aid in determining heart rate trends in general.
12. The exercise bike does not have a free wheel; the pedals will continue to move until the flywheel stops. Reduce your pedaling speed in a controlled way.
13. Always keep your back straight while using the exercise bike; do not arch your back.
14. Over exercising may result in serious injury or death. If you feel faint or if you experience pain while exercising, stop immediately and cool down.

BEFORE YOU BEGIN

Thank you for selecting the PROFORM® XP 185 U exercise bike. Cycling is an effective exercise for increasing cardiovascular fitness, building endurance, and toning the body. The XP 185 U exercise bike provides an impressive selection of features designed to make your workouts at home more effective and enjoyable.

For your benefit, read this manual carefully before you use the exercise bike. If you have questions

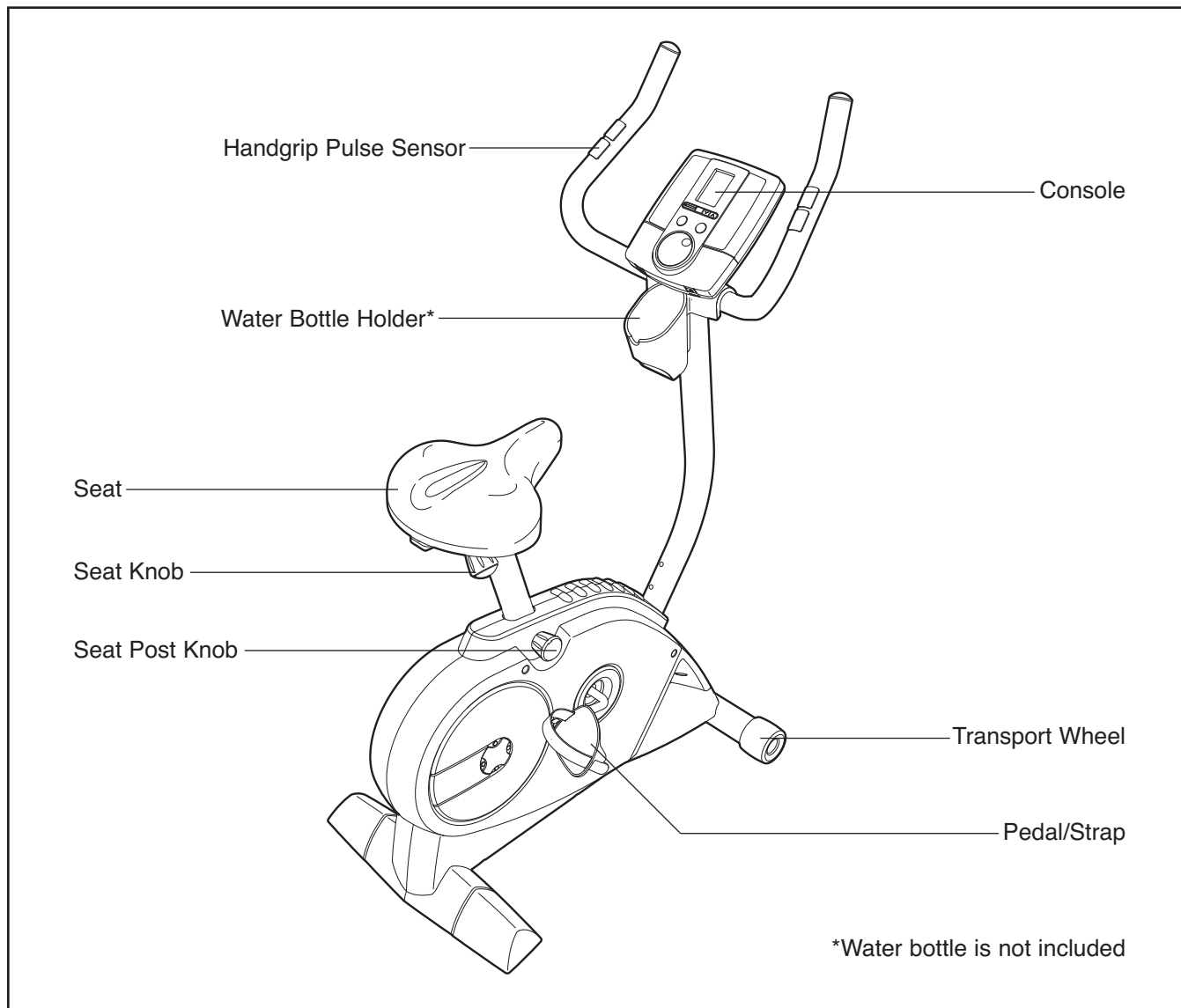

after reading this manual, please see the back cover of this manual. To help us assist you, note the product model number and serial number before contacting us. The model number and the location of the serial number decal are shown on the front cover of this manual.

Before reading further, please familiarize yourself with the parts that are labeled in the drawing below.



ASSEMBLY

Assembly requires two persons. Place all parts of the exercise bike in a cleared area and remove the packing materials. Do not dispose of the packing materials until assembly is completed.

Assembly requires the included tool(s) and your own adjustable wrench  and Phillips screwdriver .

See the drawings below to identify the small parts needed for assembly. The number in parentheses below each drawing is the key number of the part, from the PART LIST near the end of this manual. The number following the key number is the quantity needed for assembly. **Note: If a part is not in the hardware kit, check to see if it has been preassembled. To avoid damaging parts, do not use power tools for assembly. If a part is missing, call 1-888-533-1333.**

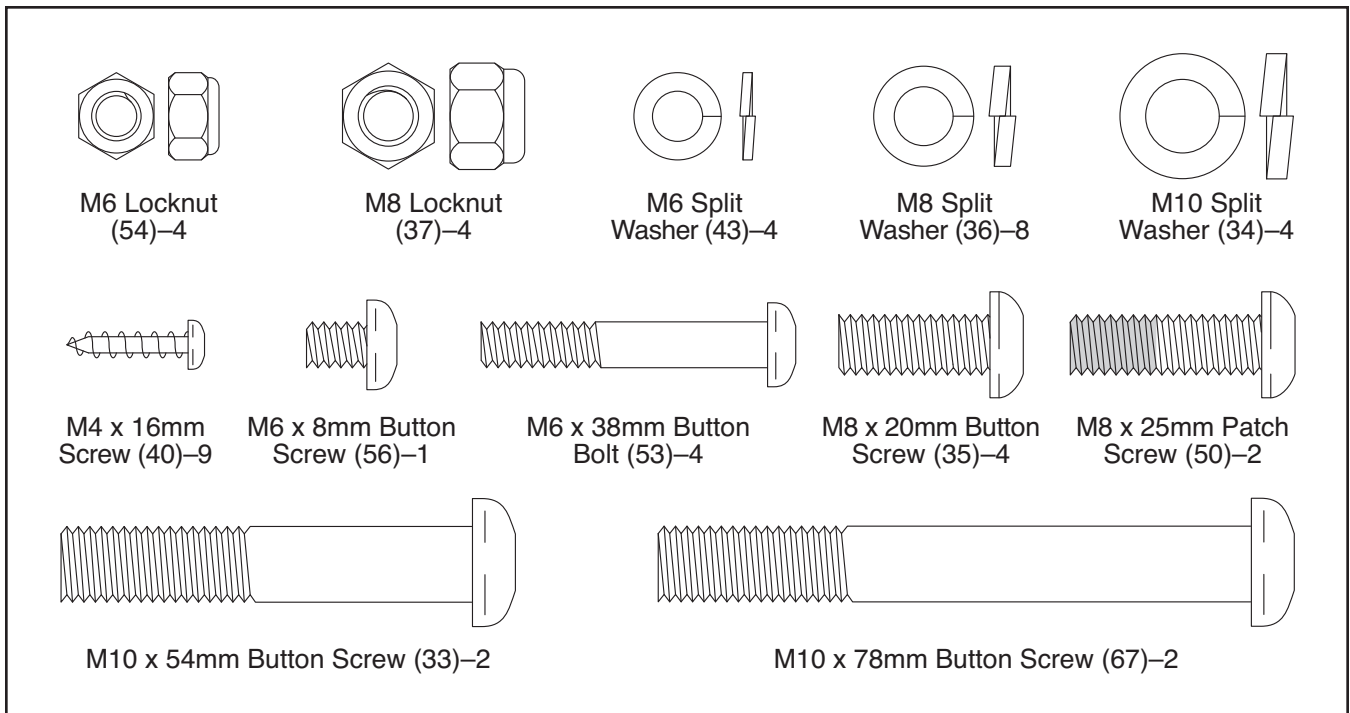

1.

To make assembly easier, read the information on page 5 before you begin.

Orient the Rear Stabilizer (14) so that the indicated holes are at the bottom.

While a second person lifts the rear of the Frame (1), attach the Rear Stabilizer (14) to the Frame with two M10 x 54mm Button Screws (33) and two M10 Split Washers (34).

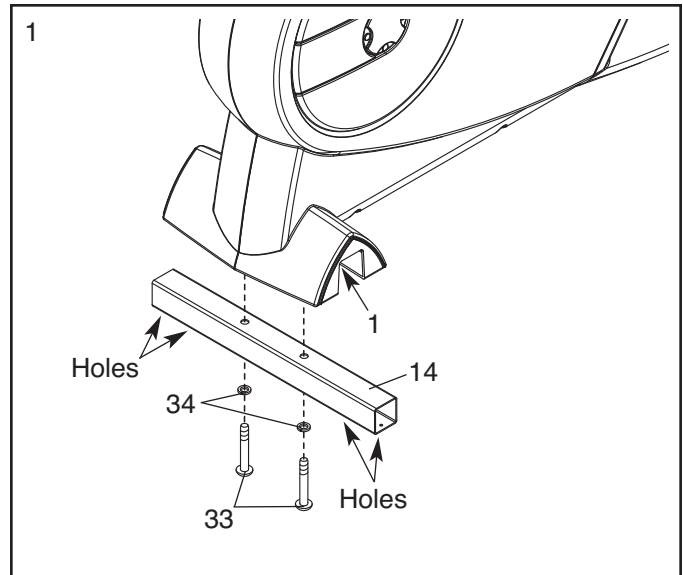

2. Slide the Right Cap (77), which is marked with a "Right" sticker, onto the right side of the Rear Stabilizer (14).

Attach the Right Cap (77) with two M4 x 16mm Screws (40).

Attach the Left Cap (4) in the same way.

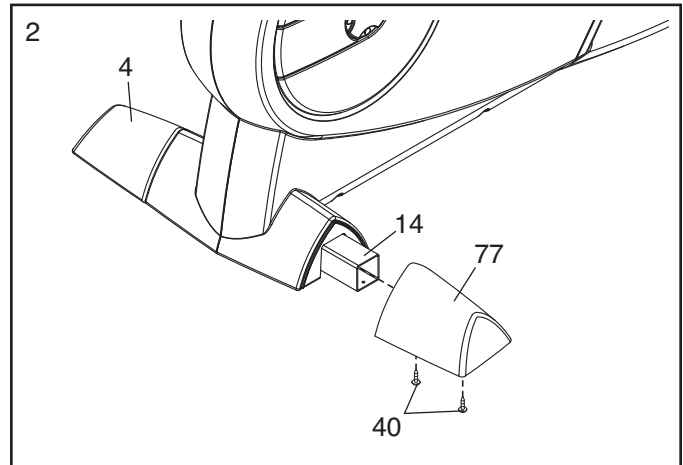

3. While a second person lifts the front of the Frame (1), attach the Front Stabilizer (2) to the Frame with two M10 x 78mm Button Screws (67) and two M10 Split Washers (34).

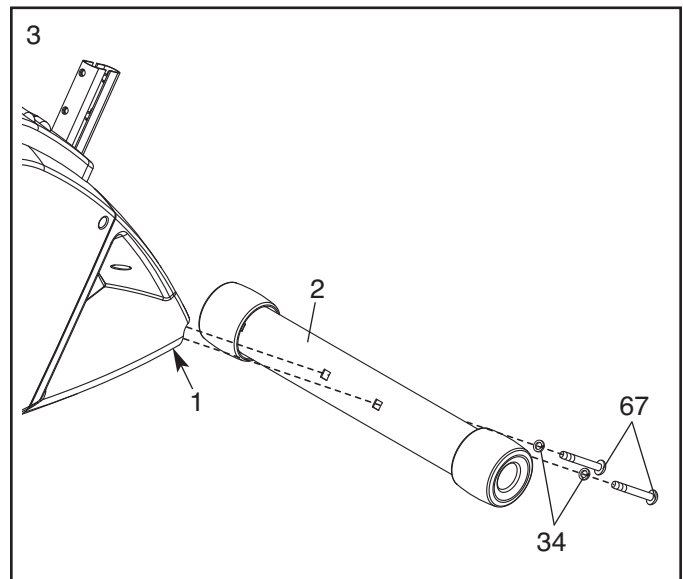

- While another person holds the Upright (3) near the Frame (1), connect the Upper Wire Harness (32) to the Lower Wire Harness (31).

Tip: Avoid pinching the wires. Gently pull the upper end of the Upper Wire Harness (32) to remove the slack, and slide the Upright (3) onto the Frame (1).

Attach the Upright (3) with four M8 x 20mm Button Screws (35) and four M8 Split Washers (36).

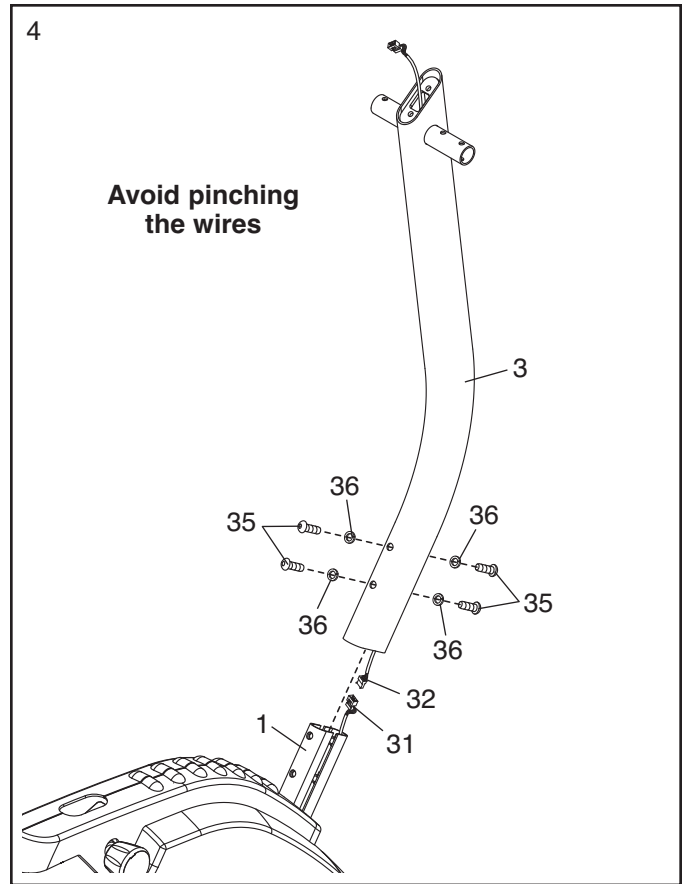

- Identify the Right Handlebar (48), which is marked with an "R" sticker.

While a second person holds the Right Handlebar (48) near the Upright (3), tie the pull wire (see the inset drawing) to the right pulse wire, and pull it into the side of the Upright and out of the top. Then, untie and discard the pull wire.

Slide the Right Handlebar (48) onto the Upright (3). Attach the Right Handlebar with two M6 x 38mm Button Bolts (53), two M6 Split Washers (43), and two M6 Locknuts (54). **Make sure that the hexagonal holes are in the indicated location.**

Attach the Left Handlebar (47) in the same way.

Orient the Water Bottle Holder (49) as shown. Insert the Upper Wire Harness (32) and the left and right pulse wires through the Water Bottle Holder.

Then, slide the Water Bottle Holder (49) onto the Upright (3) and attach it with an M4 x 16mm Screw (40). **Do not tighten the Screw yet.**

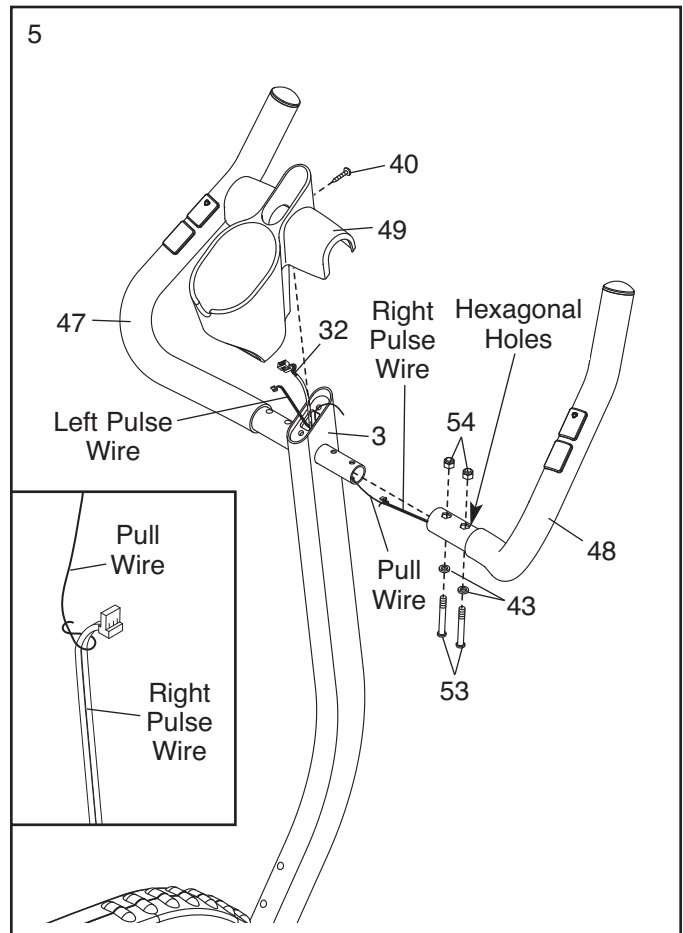

6. **Tip: Avoid pinching the wires.** Orient the Console Bracket (55) as shown and then insert the Upper Wire Harness (32) and the left and right pulse wires through the Console Bracket.

Attach the Console Bracket (55) to the Upright (3) with two M8 x 25mm Patch Screws (50).

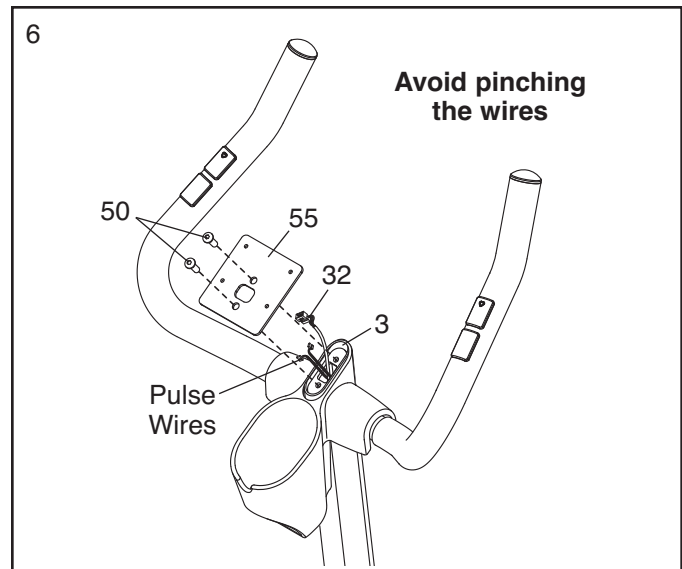

7. While another person holds the Console (6) near the Upright (3), connect the console wires to the Upper Wire Harness (32) and to the pulse wires.

Tip: Avoid pinching the wires. Insert the excess wires downward into the Upright (3).

Attach the Console (6) to the Console Bracket (55) with four M4 x 16mm Screws (40).

See step 5. Tighten the M4 x 16mm Screw (40).

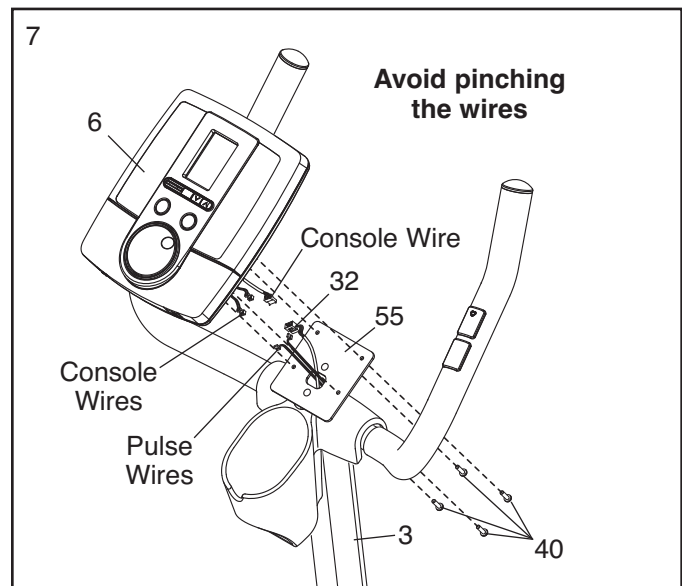

8. The Console (6) requires four D batteries (not included); alkaline batteries are recommended. **IMPORTANT: If the Console has been exposed to cold temperatures, allow it to warm to room temperature before inserting batteries. Otherwise, you may damage the console displays or other electronic components.** Remove the battery cover and insert the batteries into the battery compartments. **Make sure to orient the batteries as shown by the diagrams inside the battery compartments.** Then, reattach the battery cover.

Note: The battery cover may be attached with screws.

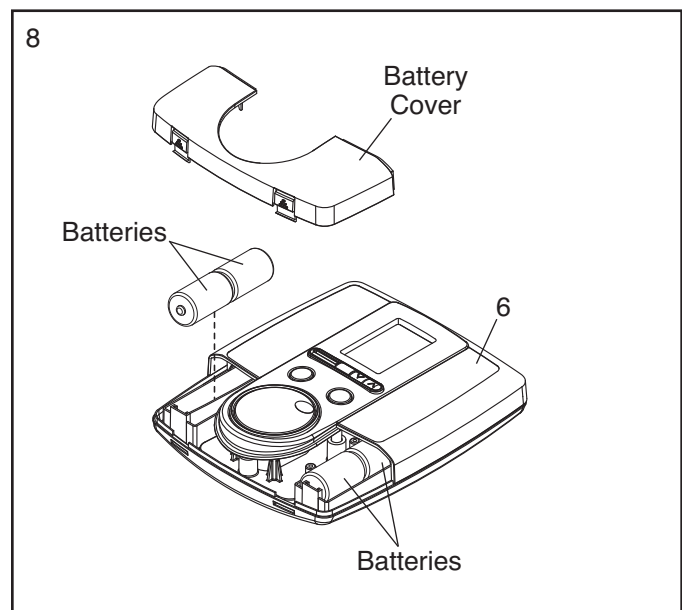

9. Orient the Seat Post (5) as shown. Loosen the Seat Post Knob (30) a few turns.

Next, pull the Seat Post Knob (30) outward, insert the Seat Post (5) into the Frame (1), and then release the Seat Post Knob into one of the holes in the Seat Post.

Move the Seat Post (5) upward and downward slightly to make sure that the pin on the Seat Post Knob (30) is engaged in one of the adjustment holes in the Seat Post. Then, tighten the Seat Post Knob.

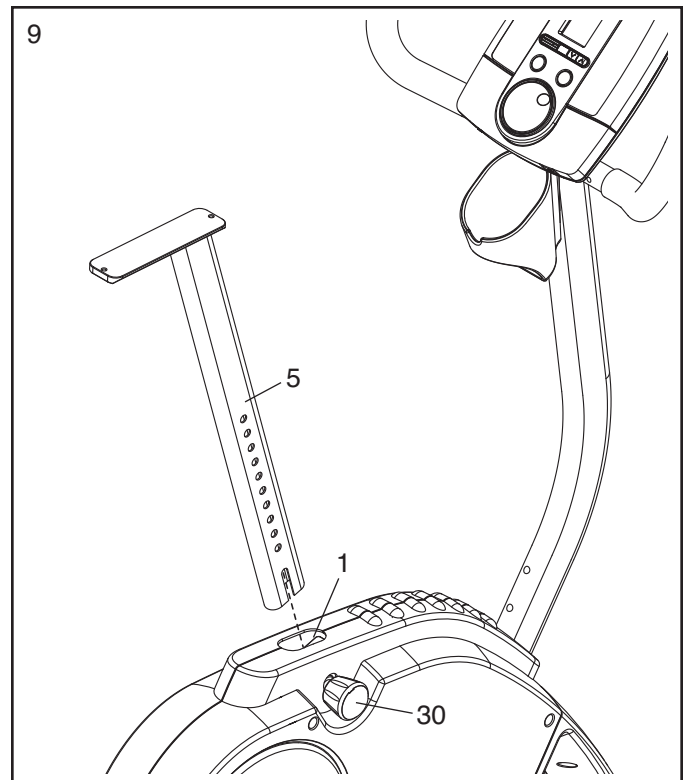

10. Orient the Seat (12) and the Seat Carriage (29) as shown.

Attach the Seat (12) to the Seat Carriage (29) with four M8 Locknuts (37) and four M8 Split Washers (36).

Loosen the Seat Knob (11) and slide the Seat Carriage (29) onto the Seat Post (5) until it stops.

Next, attach an M6 x 8mm Button Screw (56) to the Seat Post (5). Then, adjust the Seat Carriage (29) to the desired position and tighten the Seat Knob (11).

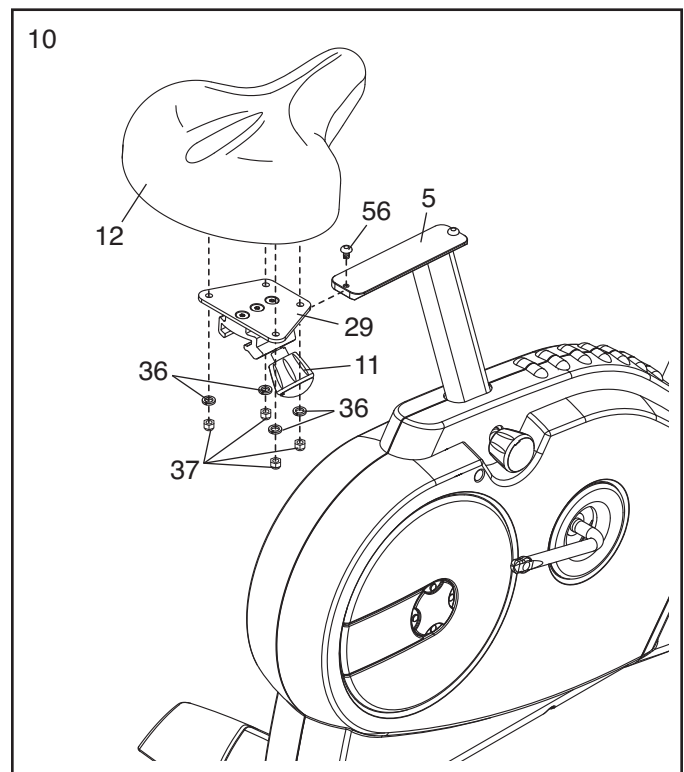

11. Identify the Right Pedal (26), which is marked with an "R."

Using an adjustable wrench, **firmly tighten** the Right Pedal **clockwise** into the right arm of the Crank (13).

Tighten the Left Pedal (not shown) **counter-clockwise** into the left arm of the Crank.

Adjust the strap on the Right Pedal (26) to the desired position, and press the end of the strap onto the tab on the side of the Right Pedal.

Adjust the strap on the Left Pedal (not shown) in the same way.

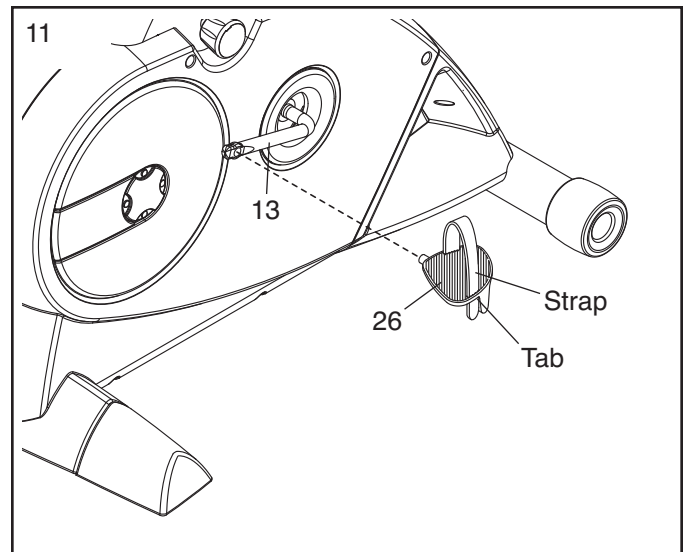

12. **Make sure that all parts are properly tightened before you use the exercise bike.** Note: After assembly is completed, some extra parts may be left over. Place a mat beneath the exercise bike to protect the floor.

HOW TO OPERATE THE EXERCISE BIKE

HOW TO ADJUST THE HEIGHT OF THE SEAT

For effective exercise, the seat should be at the proper height. As you pedal, there should be a slight bend in your knees when the pedals are in the lowest position. To adjust the height of the seat, first loosen the seat post knob.

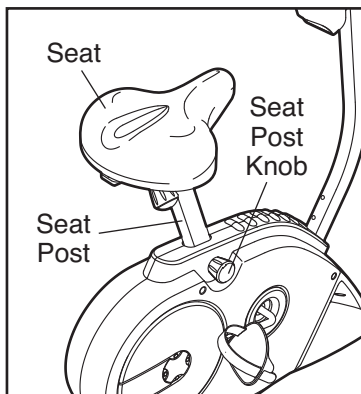

Next, pull the knob, slide the seat post upward or downward to the desired position, and then release the knob. **Move the seat post upward or downward slightly to make sure that the knob is engaged in one of the adjustment holes in the seat post.** Then, tighten the knob.

HOW TO ADJUST THE LATERAL POSITION OF THE SEAT

To adjust the lateral position of the seat, first loosen the seat knob a few turns. Then, move the seat forward or backward to the desired position, and firmly tighten the seat knob.

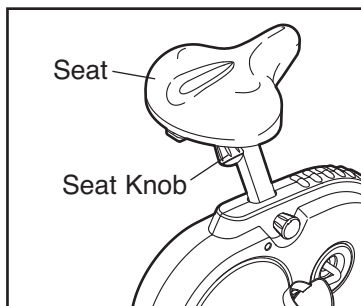

HOW TO ADJUST THE PEDAL STRAPS

To adjust the pedal straps, first pull the ends of the pedal straps off the tabs on the pedals. Adjust the pedal straps to the desired position, and then press the ends of the pedal straps onto the tabs.

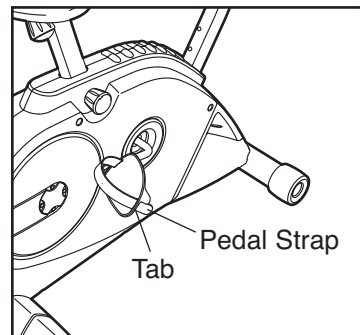

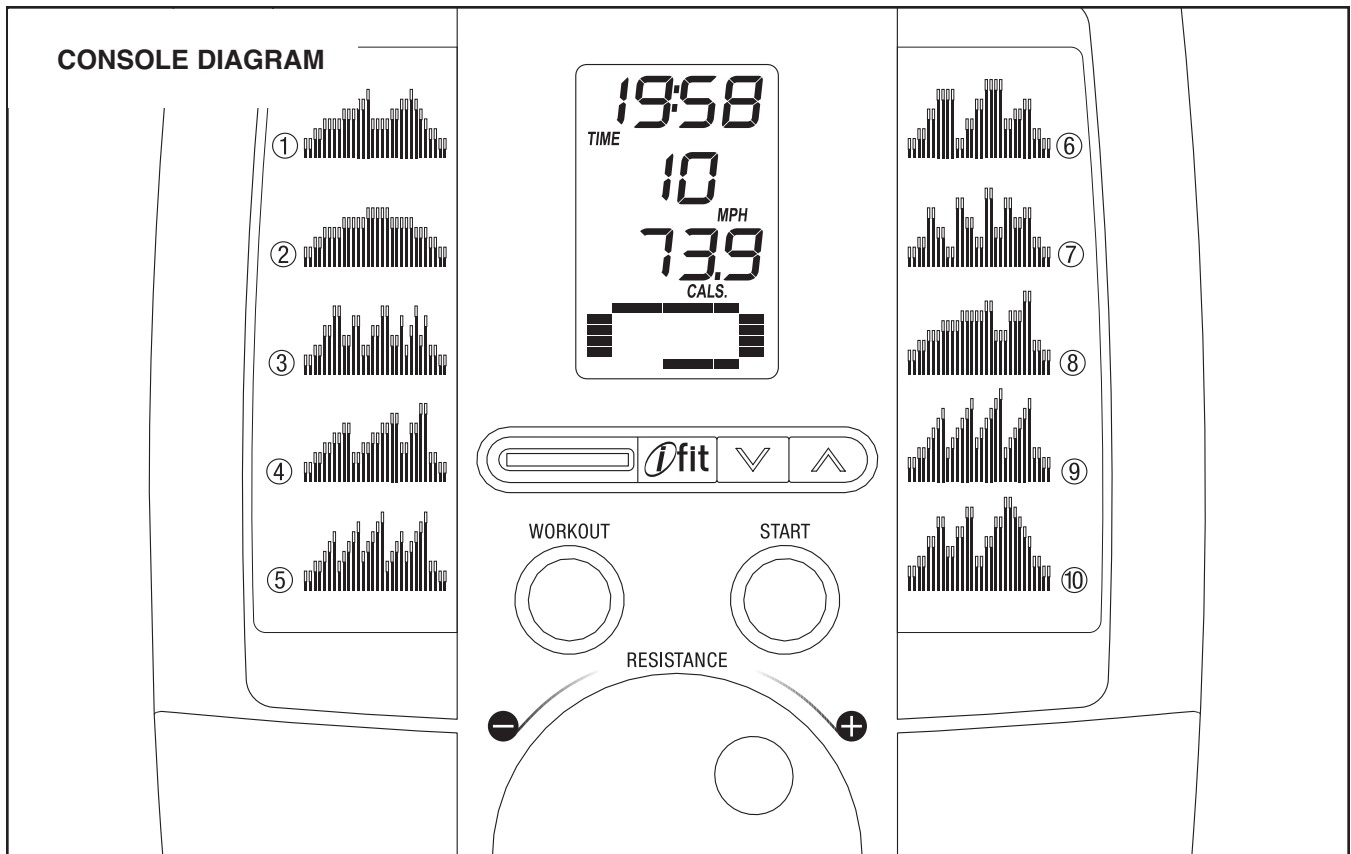

FEATURES OF THE CONSOLE

The advanced console offers an array of features designed to make your workouts more effective and enjoyable.

When you select the manual mode of the console, you can change the resistance of the pedals with the touch of a button. As you exercise, the console will provide continuous exercise feedback. You can even measure your heart rate using the handgrip pulse sensor.

The console also offers ten preset workouts. Each workout automatically changes the resistance of the pedals and prompts you to increase or decrease your pedaling pace as it guides you through an effective workout.

The console also features the new iFit interactive workout system. The iFit interactive workout system enables the console to accept iFit cards containing workouts designed to help you achieve specific fitness goals.

For example, lose unwanted pounds with the 8-week Weight Loss workout. iFit workouts control the resistance of the pedals while guiding you through your workouts. iFit cards are available separately. **To purchase iFit cards, go to www.iFit.com or call the telephone number on the front cover of this manual. iFit cards are also available at select stores.**

To use the manual mode, see page 13. To use a preset workout, see page 15. To use an iFit workout, see page 16.

Note: If there is a sheet of plastic on the face of the console, remove the plastic.

HOW TO USE THE MANUAL MODE

1. Turn on the console.

To turn on the console, press any button or begin pedaling. The display will light and the console will be ready for use.

2. Select the manual mode.

Each time you turn on the console, the manual mode will be selected. If you have selected a workout, reselect the manual mode by pressing the Workout button repeatedly until zeros appear in the display.



3. Begin pedaling and change the resistance of the pedals as desired.

As you pedal, change the resistance of the pedals by turning the Resistance dial. To increase the resistance, turn the Resistance dial clockwise; to decrease the resistance, turn the Resistance dial counterclockwise. Note: After you change the resistance, it will take a moment for the pedals to reach the selected resistance level.

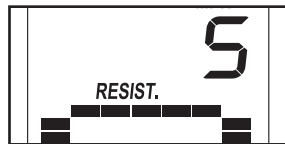

4. Follow your progress with the display.

The upper section of the display will show the elapsed time and the distance, in miles or kilometers, that you have pedaled. The display will change modes every few seconds. Note: When you select a preset workout the display will show the time remaining in the workout instead of the elapsed time.



The second section of the display will show your pedaling pace in miles or kilometers per hour.



The third section of the display will show the approximate number of calories you have burned and the resistance level of the pedals. The display will change modes every few seconds.



The display will also show your heart rate when you use the handgrip pulse sensor (see step 5 on page 14).

The last section of the display will show a track representing 1/4 mile (400 meters). As you exercise, indicators will appear in succession around the track until the entire track appears. The track will then disappear and the indicators will again begin to appear in succession.

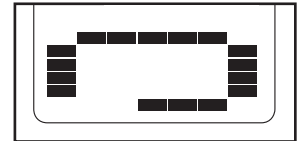

Note: The console can show speed and distance in either miles or kilometers. The letters MPH or Km/H will appear in the display to indicate which unit of measurement is selected.

To change the unit of measurement, press and hold down the Workout button for a few seconds. An E for English miles or an M for metric kilometers will appear in the display. Press the Start button repeatedly to select the desired unit of measurement. Then, press the Workout button.

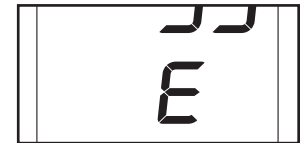

Note: When you replace the batteries, it may be necessary to reselect the unit of measurement.

To view the total distance pedaled since the exercise bike was purchased and the total number of hours the exercise bike has been used, press and hold down the Workout button for a few seconds.

The total distance pedaled will appear in the first section of the display. The total number of hours the exercise bike has been used will appear in the third section of the display. To return to the manual mode, press the Workout button.

5. **Measure your heart rate if desired.**

If there are sheets of plastic on the metal contacts on the handgrip pulse sensor, remove the plastic. Next, hold the handgrip pulse sensor with your palms resting on the metal contacts.

Avoid moving your hands or gripping the contacts too tightly. When your pulse is detected, a heart-shaped symbol will flash in the display each time your heart beats and then your heart rate will be shown. For the most accurate heart rate reading, hold the contacts for at least 15 seconds.

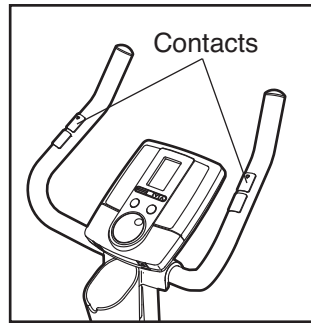

6. **When you are finished exercising, the console will turn off automatically.**

If the pedals do not move for a few seconds, the time will begin to flash in the display and the console will pause.

If the pedals do not move for a few minutes and no buttons are pressed, the console will turn off and the display will be reset.

HOW TO USE A PRESET WORKOUT

1. Turn on the console.

To turn on the console, press any button or begin pedaling. The display will light and the console will be ready for use.

2. Select a preset workout.

To select a preset workout, press the Workout button repeatedly until the number of the desired workout appears in the display.



The first section of the display will show how long the workout will last. A profile of the resistance levels for the workout will scroll across the last section of the display. Note: Complete profiles of the preset workouts are printed on the sides of the console.

3. Press the Start button or begin pedaling to start the workout.

Each workout is divided into 30 one-minute segments. One resistance level and one pace setting are programmed for each segment. Note: The same resistance level and/or pace setting may be programmed for consecutive segments.

During the workout, the workout profile will show your progress. The flashing segment of the profile represents the current segment of the workout. The height of the flashing segment indicates the resistance level for the current segment. At the end of each segment of the workout, a series of tones will sound and the next segment of the profile will begin to flash. If a different resistance level is programmed for the next segment, the resistance level will flash in the center display for a few seconds to alert you. The resistance of the pedals will then change.

As you exercise, the display will prompt you to keep your pedaling pace near the pace setting for the current segment. When the word “faster” appears in the display, increase your pace. When the word “slower” appears, decrease your pace. When the center of the target flashes, maintain your current pace.



IMPORTANT: The pace settings are intended only to provide motivation. Your actual pace may be slower than the pace settings. Make sure to pedal at a pace that is comfortable for you.

If the resistance level for the current segment is too high or too low, you can manually override the level by turning the Resistance dial. **IMPORTANT: When the current segment of the workout ends, the pedals will automatically adjust to the resistance setting for the next segment.**

If you stop pedaling for several seconds, the time will begin to flash in the display. To restart the workout, press the Start button or simply resume pedaling.

The workout will continue until the display shows a time of 0:00. If you continue to pedal after the workout is completed, the display will continue to show exercise feedback; however, the display will not show the elapsed time until you select the manual mode or a new workout.

4. Follow your progress with the display.

See step 4 on page 13.

5. Measure your heart rate if desired.

See step 5 on page 14.

6. When you are finished exercising, the console will turn off automatically.

See step 6 on page 14.

HOW TO USE AN IFIT WORKOUT

1. **Press any button on the console or begin pedaling to turn on the console.**

When you turn on the console, the display will light. A tone will then sound and the console will be ready for use.

2. **Insert an iFit card and select a workout.**

To use an iFit workout, insert an iFit card into the iFit slot; make sure that the iFit card is oriented so the metal contacts are face-down and are facing the slot. When the iFit card is properly inserted, the indicator next to the slot will light and words will appear in the display.

Next, select the desired workout on the iFit card by pressing the up and down buttons next to the iFit slot.

Press the Start button or begin pedaling to start your workout. iFit workouts function in the same way as preset workouts. To use the workout, see steps 3 to 6 on page 15.

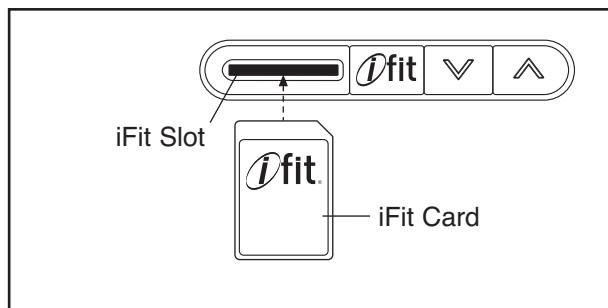

MAINTENANCE AND TROUBLESHOOTING

Inspect and tighten all parts of the exercise bike regularly. To clean the exercise bike, use a damp cloth and a small amount of mild detergent; **never use abrasives or solvents to clean the exercise bike. To avoid damaging the console, keep liquid away from the console.**

CONSOLE TROUBLESHOOTING

If the console display becomes dim, replace all the batteries at the same time; most console problems are the result of low batteries. To replace the batteries, see assembly step 8 on page 9.

If the console does not display your heart rate when you use the handgrip pulse sensor, see step 5 on page 14.

HOW TO ADJUST THE REED SWITCH

If the console does not display correct feedback, the reed switch should be adjusted. To adjust the reed switch, you must first remove the left pedal and the left shield.

Using an adjustable wrench, turn the left pedal clockwise and remove it. Next, remove the screws from the left and right shields; **there are three sizes of screws in the shields—note which size of screw you remove from each hole.** Then, gently remove the left shield.

Locate the Reed Switch (21). Turn the Crank (13) until a Magnet (16) is aligned with the Reed Switch. Loosen, but do not remove, the indicated M4 x 16mm Flange Screw (61).

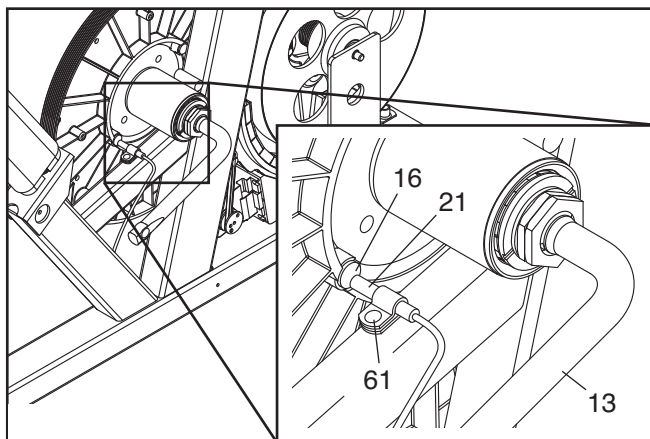

Slide the Reed Switch (21) slightly closer to or away from the Magnet (16), and then retighten the M4 x 16mm Flange Screw (61). Turn the Crank (13) for a moment.

Repeat these actions until the console displays correct feedback. When the reed switch is correctly adjusted, reattach the left shield and the left pedal.

HOW TO ADJUST THE BELT

If you can feel the pedals slip while you are pedaling, even when the resistance is at the highest level, the belt may need to be adjusted.

To adjust the belt, you must first remove the right pedal and the right shield.

Using an adjustable wrench, turn the right pedal clockwise and remove it. Next, remove the screws from the left and right shields; **there are three sizes of screws in the shields—note which size of screw you remove from each hole.** Then, gently remove the right shield.

To tighten the belt, first loosen the M10 x 22mm Bolt (45). Next, tighten the M8 x 38mm Hex Screw (69) until the belt is tight. Then, retighten the M10 x 22mm Bolt (45). Reattach the right shield and the right pedal.

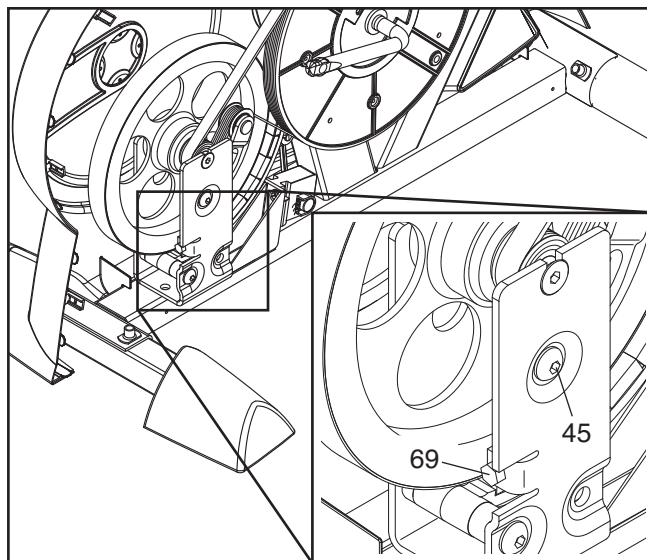

EXERCISE GUIDELINES

⚠ WARNING: Before beginning this or any exercise program, consult your physician. This is especially important for persons over age 35 or persons with pre-existing health problems.

The pulse sensor is not a medical device. Various factors may affect the accuracy of heart rate readings. The pulse sensor is intended only as an exercise aid in determining heart rate trends in general.

These guidelines will help you to plan your exercise program. For detailed exercise information, obtain a reputable book or consult your physician. Remember, proper nutrition and adequate rest are essential for successful results.

EXERCISE INTENSITY

Whether your goal is to burn fat or to strengthen your cardiovascular system, exercising at the proper intensity is the key to achieving results. You can use your heart rate as a guide to find the proper intensity level. The chart below shows recommended heart rates for fat burning and aerobic exercise.

165	155	145	140	130	125	115	♥
145	138	130	125	118	110	103	♥
125	120	115	110	105	95	90	♥
<hr/>							
20	30	40	50	60	70	80	

To find the proper intensity level, find your age at the bottom of the chart (ages are rounded off to the nearest ten years). The three numbers listed above your age define your “training zone.” The lowest number is the heart rate for fat burning, the middle number is the heart rate for maximum fat burning, and the highest number is the heart rate for aerobic exercise.

Burning Fat—To burn fat effectively, you must exercise at a low intensity level for a sustained period of time. During the first few minutes of exercise, your body uses *carbohydrate calories* for energy. Only after the first few minutes of exercise does your body begin to use stored *fat calories* for energy. If your goal is to burn fat, adjust the intensity of your exercise until your heart rate is near the lowest number in your training zone. For maximum fat burning, exercise with your heart rate near the middle number in your training zone.

Aerobic Exercise—If your goal is to strengthen your cardiovascular system, you must perform aerobic exercise, which is activity that requires large amounts of oxygen for prolonged periods of time. For aerobic exercise, adjust the intensity of your exercise until your heart rate is near the highest number in your training zone.

WORKOUT GUIDELINES

Warming Up—Start with 5 to 10 minutes of stretching and light exercise. A warm-up increases your body temperature, heart rate, and circulation in preparation for exercise.

Training Zone Exercise—Exercise for 20 to 30 minutes with your heart rate in your training zone. (During the first few weeks of your exercise program, do not keep your heart rate in your training zone for longer than 20 minutes.) Breathe regularly and deeply as you exercise—never hold your breath.

Cooling Down—Finish with 5 to 10 minutes of stretching. Stretching increases the flexibility of your muscles and helps to prevent post-exercise problems.

EXERCISE FREQUENCY

To maintain or improve your condition, complete three workouts each week, with at least one day of rest between workouts. After a few months of regular exercise, you may complete up to five workouts each week, if desired. Remember, the key to success is to make exercise a regular and enjoyable part of your everyday life.

SUGGESTED STRETCHES

The correct form for several basic stretches is shown at the right. Move slowly as you stretch—never bounce.

1. Toe Touch Stretch

Stand with your knees bent slightly and slowly bend forward from your hips. Allow your back and shoulders to relax as you reach down toward your toes as far as possible. Hold for 15 counts, then relax. Repeat 3 times. Stretches: Hamstrings, back of knees and back.

2. Hamstring Stretch

Sit with one leg extended. Bring the sole of the opposite foot toward you and rest it against the inner thigh of your extended leg. Reach toward your toes as far as possible. Hold for 15 counts, then relax. Repeat 3 times for each leg. Stretches: Hamstrings, lower back and groin.

3. Calf/Achilles Stretch

With one leg in front of the other, reach forward and place your hands against a wall. Keep your back leg straight and your back foot flat on the floor. Bend your front leg, lean forward and move your hips toward the wall. Hold for 15 counts, then relax. Repeat 3 times for each leg. To cause further stretching of the achilles tendons, bend your back leg as well. Stretches: Calves, achilles tendons and ankles.

4. Quadriceps Stretch

With one hand against a wall for balance, reach back and grasp one foot with your other hand. Bring your heel as close to your buttocks as possible. Hold for 15 counts, then relax. Repeat 3 times for each leg. Stretches: Quadriceps and hip muscles.

5. Inner Thigh Stretch

Sit with the soles of your feet together and your knees outward. Pull your feet toward your groin area as far as possible. Hold for 15 counts, then relax. Repeat 3 times. Stretches: Quadriceps and hip muscles.

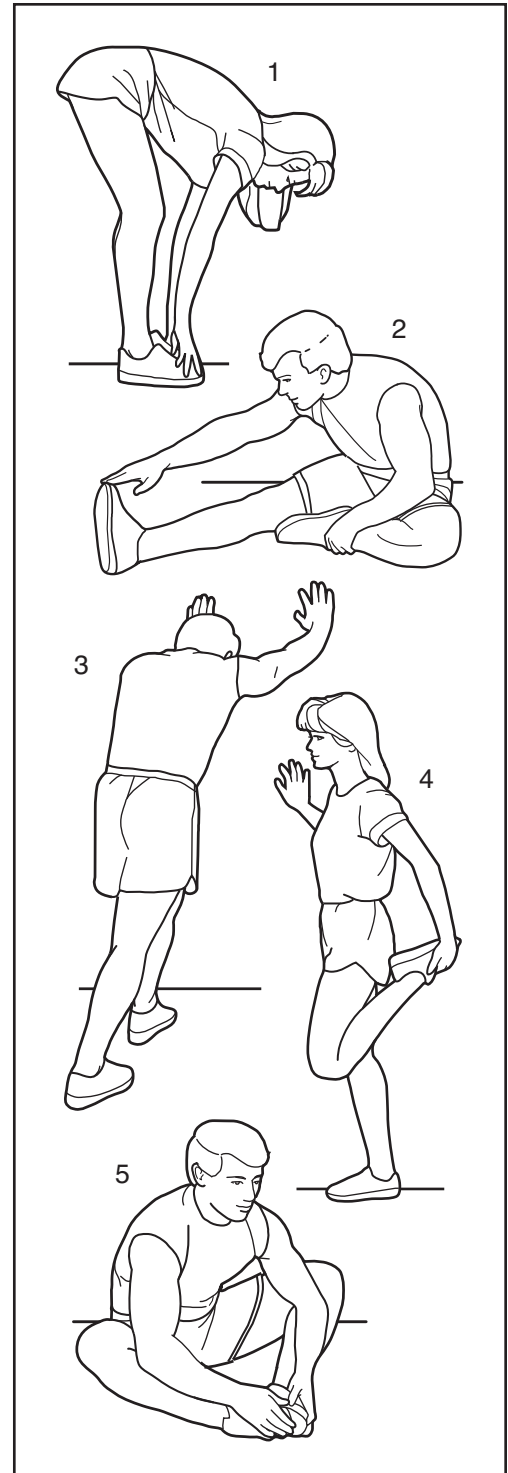

NOTES

NOTES

PART LIST

Model No. 831.21741.0 R1110A

Key No.	Qty.	Description	Key No.	Qty.	Description
1	1	Frame	41	1	M4 x 30mm Screw
2	1	Front Stabilizer	42	1	Flywheel Axle
3	1	Upright	43	4	M6 Split Washer
4	1	Left Cap	44	1	Long C-magnet Spacer
5	1	Seat Post	45	1	M10 x 22mm Bolt
6	1	Console	46	1	C-magnet
7	1	Flywheel	47	1	Left Handlebar w/Pulse Wire
8	1	Resistance Motor	48	1	Right Handlebar w/Pulse Wire
9	4	M4 x 12mm Screw	49	1	Water Bottle Holder
10	1	Resistance Arm	50	2	M8 x 25mm Patch Screw
11	1	Seat Knob	51	2	Handlebar Cap
12	1	Seat	52	1	M10 Locknut
13	1	Pulley/Crank	53	4	M6 x 38mm Button Bolt
14	1	Rear Stabilizer	54	4	M6 Locknut
15	2	Transport Wheel	55	1	Console Bracket
16	2	Magnet	56	2	M6 x 8mm Button Screw
17	1	Left Shield	57	1	Short C-magnet Spacer
18	1	Right Shield	58	4	V-clip
19	1	Resistance Motor Bracket	59	1	M10 x 80mm Shoulder Bolt
20	1	Seat Post Bushing	60	1	Resistance Wheel
21	1	Reed Switch/Wire	61	7	M4 x 16mm Flange Screw
22	2	Clamp	62	1	M3.5 x 12mm Screw
23	1	Belt	63	2	Foot
24	1	Left Pedal/Strap	64	1	M4 x 5mm Screw
25	2	Flywheel Bearing	65	4	M3.8 x 20mm Round Head Screw
26	1	Right Pedal/Strap	66	3	M10 Washer
27	1	Crank Bearing Set	67	2	M10 x 78mm Button Screw
28	1	Idler	68	1	M4 x 16mm Bright Screw
29	1	Seat Carriage	69	1	M8 x 38mm Hex Screw
30	1	Seat Post Knob	70	4	M4 Locknut
31	1	Lower Wire Harness	71	3	M8 x 20mm Flat Head Screw
32	1	Upper Wire Harness	72	2	Foam Grip
33	2	M10 x 54mm Button Screw	73	1	Seat Plate
34	4	M10 Split Washer	74	2	Upper Contact
35	4	M8 x 20mm Button Screw	75	2	Lower Contact
36	8	M8 Split Washer	76	1	Wire Clamp
37	6	M8 Locknut	77	1	Right Cap
38	2	M8 x 25mm Shoulder Patch Screw	*	–	User's Manual
39	2	M4 x 64mm Screw	*	–	Assembly Tool
40	17	M4 x 16mm Screw			

Note: Specifications are subject to change without notice. For information about ordering replacement parts, see the back cover of this manual. **If a part is missing, call 1-888-533-1333.** *These parts are not illustrated.

EXPLODED DRAWING

Model No. 831.21741.0 R1110A

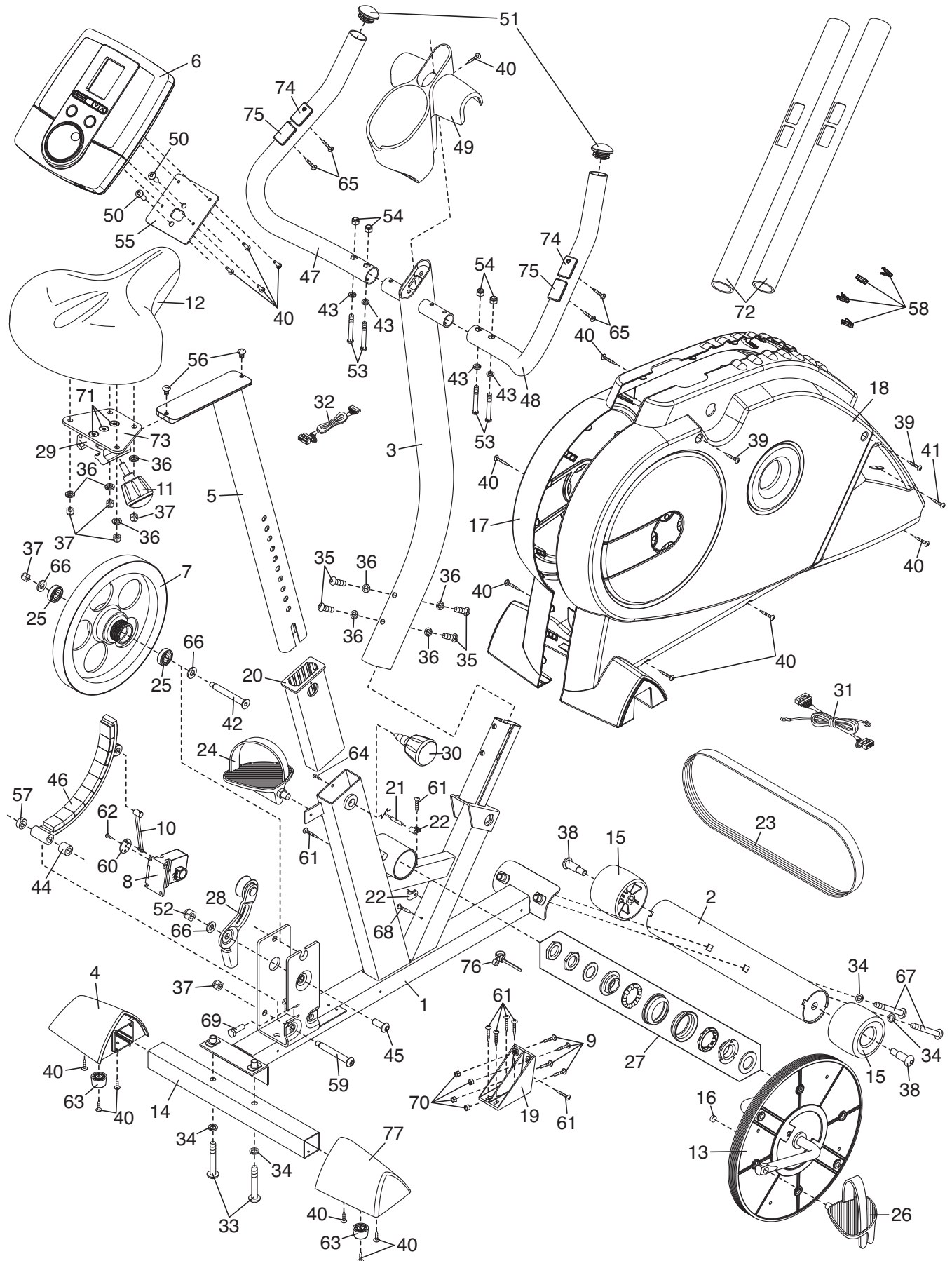

Get it fixed, at your home or ours!

Your Home

For repair—**in your home**—of **all** major brand appliances, lawn and garden equipment, or heating and cooling systems, **no matter who made it, no matter who sold it!**

For the replacement parts, accessories, and user's manuals that you need to do-it-yourself.

For Sears professional installation of home appliances and items like garage door openers and water heaters.

1-800-4-MY-HOME® (1-800-469-4663)

Call anytime, day or night (U.S.A. and Canada)

www.sears.com

www.sears.ca

Our Home

For repair of carry-in items like vacuums, lawn equipment, and electronics, call or go on-line for the location of your nearest **Sears Parts & Repair Center.**

1-800-488-1222 Call anytime, day or night (U.S.A. only)

www.sears.com

To purchase a protection agreement (U.S.A.) or maintenance agreement (Canada) on a product serviced by Sears:

1-800-827-6655 (U.S.A.)

1-800-361-6665 (Canada)

Para pedir servicio de reparación a domicilio, y para ordenar piezas:

1-888-SU-HOGAR® (1-888-784-6427)



® Registered Trademark / ™ Trademark / ™ Service Mark of Sears Brands, LLC
© Marca Registrada / ™ Marca de Fábrica / ™ Marca de Servicio de Sears Brands, LLC

90 DAY FULL WARRANTY

If this Sears bike exerciser fails due to a defect in material or workmanship within 90 days of the date of purchase, call 1-800-4-MY-HOME® (1-800-469-4663) to arrange for free repair (or replacement if repair proves impossible).

This warranty does not apply when the bike exerciser is used commercially or for rental purposes.

This warranty gives you specific legal rights, and you may also have other rights which vary from state to state.

Sears, Roebuck and Co., Hoffman Estates, IL 60179