

PRO-FORM[®] XP110

Patent Pending

Model No. 831.28543.0

Serial No. _____

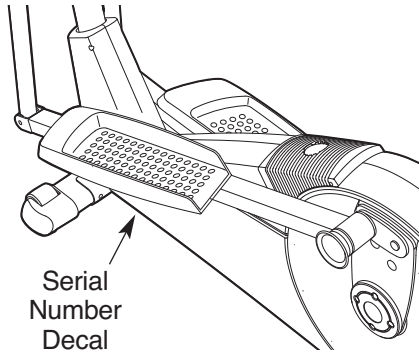

- **Assembly**
- **Operation**
- **Maintenance**
- **Part List and Drawing**

⚠ CAUTION

Read all precautions and instructions in this manual before using this equipment. Keep this manual for future reference.

ELLIPTICAL EXERCISER User's Manual

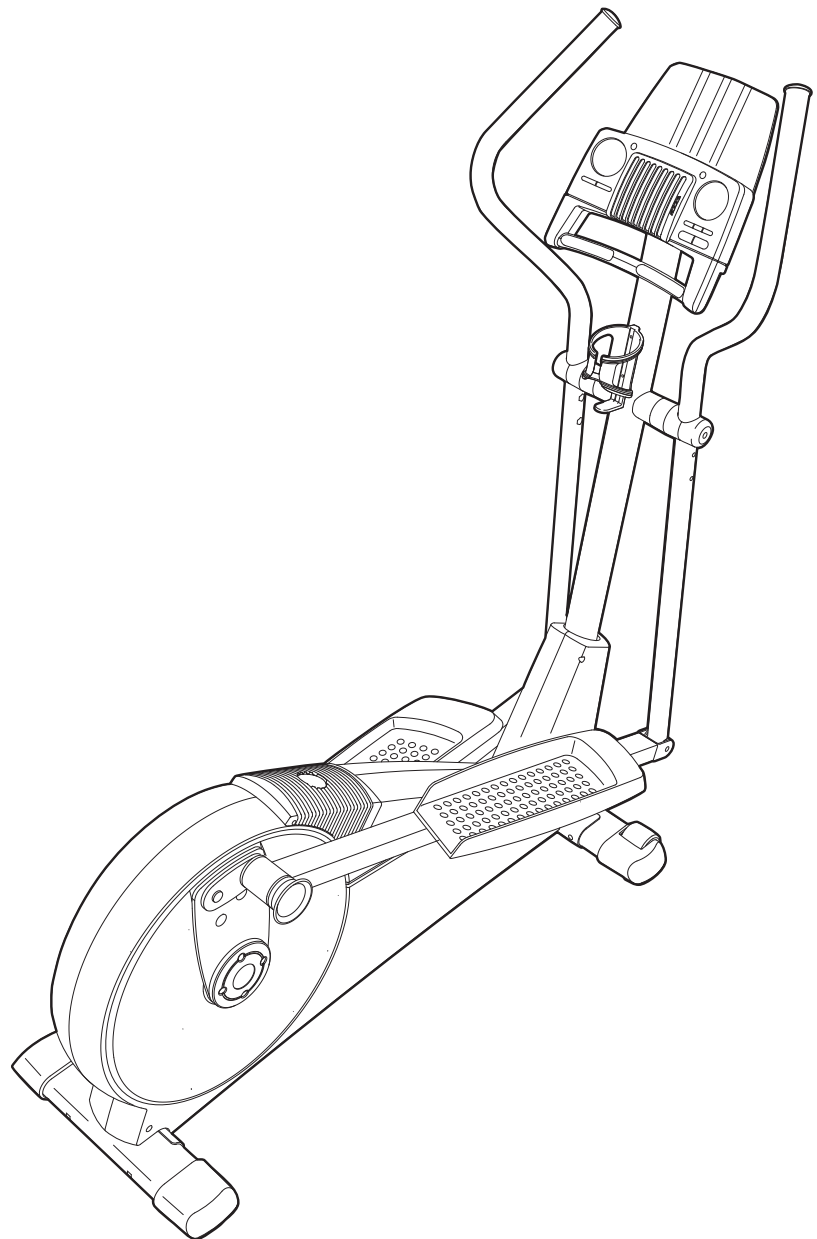

Sears, Roebuck and Co., Hoffman Estates, IL 60179

PRO-FORM® XP110

TABLE OF CONTENTS

IMPORTANT PRECAUTIONS3
BEFORE YOU BEGIN4
ASSEMBLY5
HOW TO USE THE ELLIPTICAL EXERCISER9
MAINTENANCE AND TROUBLESHOOTING19
CONDITIONING GUIDELINES20
PART LIST21
EXPLODED DRAWING22
HOW TO ORDER REPLACEMENT PARTSBack Cover
FULL 90 DAY WARRANTYBack Cover

IMPORTANT PRECAUTIONS

⚠ WARNING: To reduce the risk of serious injury, read the following important precautions before using the elliptical exerciser.

1. Read all instructions in this manual and all warnings on the elliptical exerciser before using the elliptical exerciser. Use the elliptical exercise only as described in this manual.
2. It is the responsibility of the owner to ensure that all users of the elliptical exerciser are adequately informed of all precautions.
3. The elliptical exerciser is intended for home use only. Do not use the elliptical exerciser in a commercial, rental, or institutional setting.
4. Keep the elliptical exerciser indoors, away from moisture and dust. Place the elliptical exerciser on a level surface, with a mat beneath it to protect the floor or carpet. Make sure that there is enough clearance around the elliptical exerciser to mount, dismount, and use it.
5. Inspect and properly tighten all parts regularly. Replace any worn parts immediately.
6. Keep children under 12 and pets away from the elliptical exerciser at all times.
7. The elliptical exerciser should not be used by persons weighing more than 250 pounds.
8. Wear appropriate exercise clothes when using the elliptical exerciser. Always wear athletic shoes for foot protection while exercising.
9. Hold the handgrip pulse sensor or the handlebars when mounting, dismounting, or using the elliptical exerciser.
10. The pulse sensor is not a medical device. Various factors may affect the accuracy of heart rate readings. The pulse sensor is intended only as an exercise aid in determining heart rate trends in general.
11. Keep your back straight when using the elliptical exerciser; do not arch your back.
12. If you feel pain or dizziness while exercising, stop immediately and cool down.
13. When you stop exercising, allow the pedals to slowly come to a stop.
14. The decal shown below has been placed on the elliptical exerciser. If the decal is missing, or if it is not legible, please call toll-free 1-888-533-1333 and order a free replacement decal. Apply the decal in the location shown.

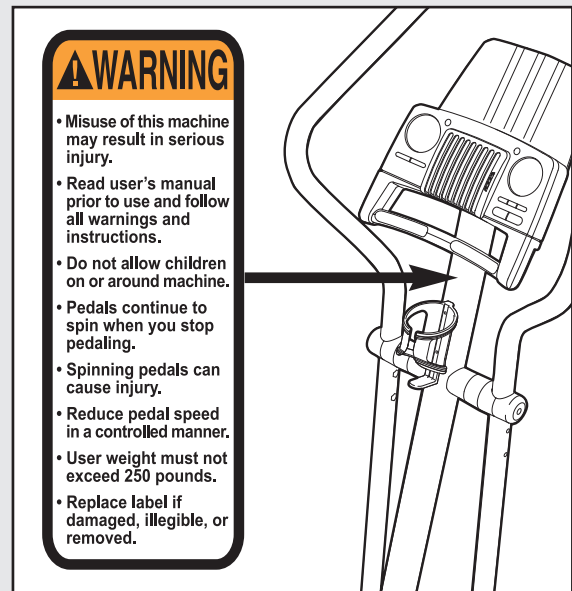

⚠ WARNING: Before beginning this or any exercise program, consult your physician. This is especially important for persons over the age of 35 or persons with pre-existing health problems. Read all instructions before using. Sears assumes no responsibility for personal injury or property damage sustained by or through the use of this product.

BEFORE YOU BEGIN

Congratulations for selecting the new PROFORM® XP 110 elliptical exerciser. The PROFORM XP 110 is an incredibly smooth exerciser that moves your feet in a natural elliptical path, minimizing the impact on your knees and ankles. And the unique XP 110 features adjustable resistance and a state-of-the-art console to help you get the most from your exercise.



After reading this manual, call 1-800-4-MY-HOME® (1-800-469-4663). To help us assist you, please note the product model number and serial number before calling. The model number is 831.28543.0. The serial number can be found on a decal attached to the elliptical exerciser (see the front cover of this manual for the location of the decal).

For your benefit, read this manual carefully before you use the elliptical exerciser. If you have ques-

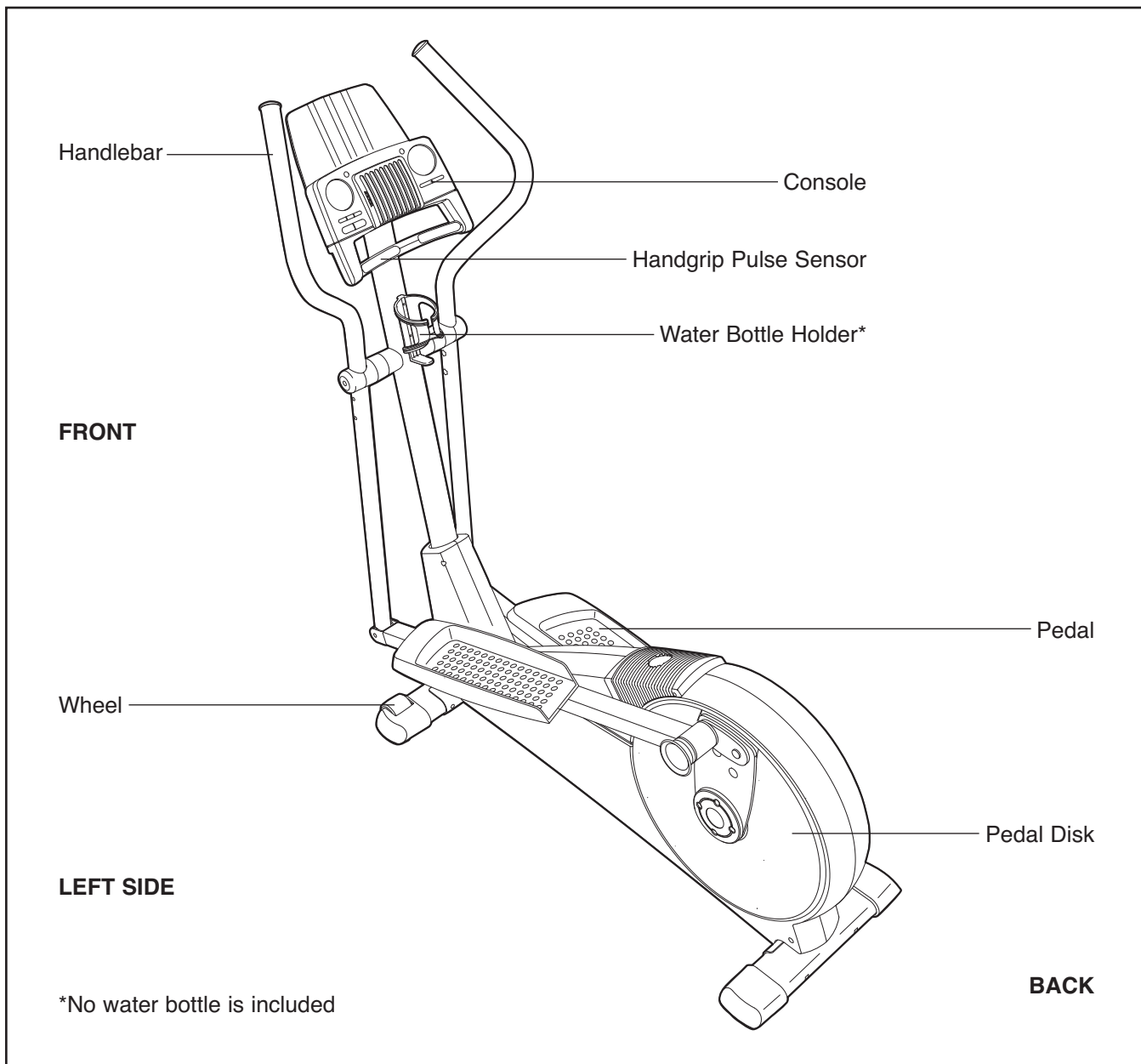
Before reading further, please familiarize yourself with the parts that are labeled in the drawing below.



ASSEMBLY

Assembly requires two persons. Place all parts of the elliptical exerciser in a cleared area and remove the packing materials. Do not dispose of the packing materials until assembly is completed. **In addition to the included allen wrenches, assembly requires a phillips screwdriver** , **an adjustable wrench** , **and a rubber mallet** .

As you assemble the elliptical exerciser, use the drawings below to identify small parts. The number in parentheses below each drawing is the key number of the part, from the PART LIST on page 21. The second number is the quantity needed for assembly. **Note: Some small parts may have been pre-assembled. If a part is not in the parts bag, check to see if it has been pre-assembled. If a part is missing, call toll-free 1-888-533-1333.**

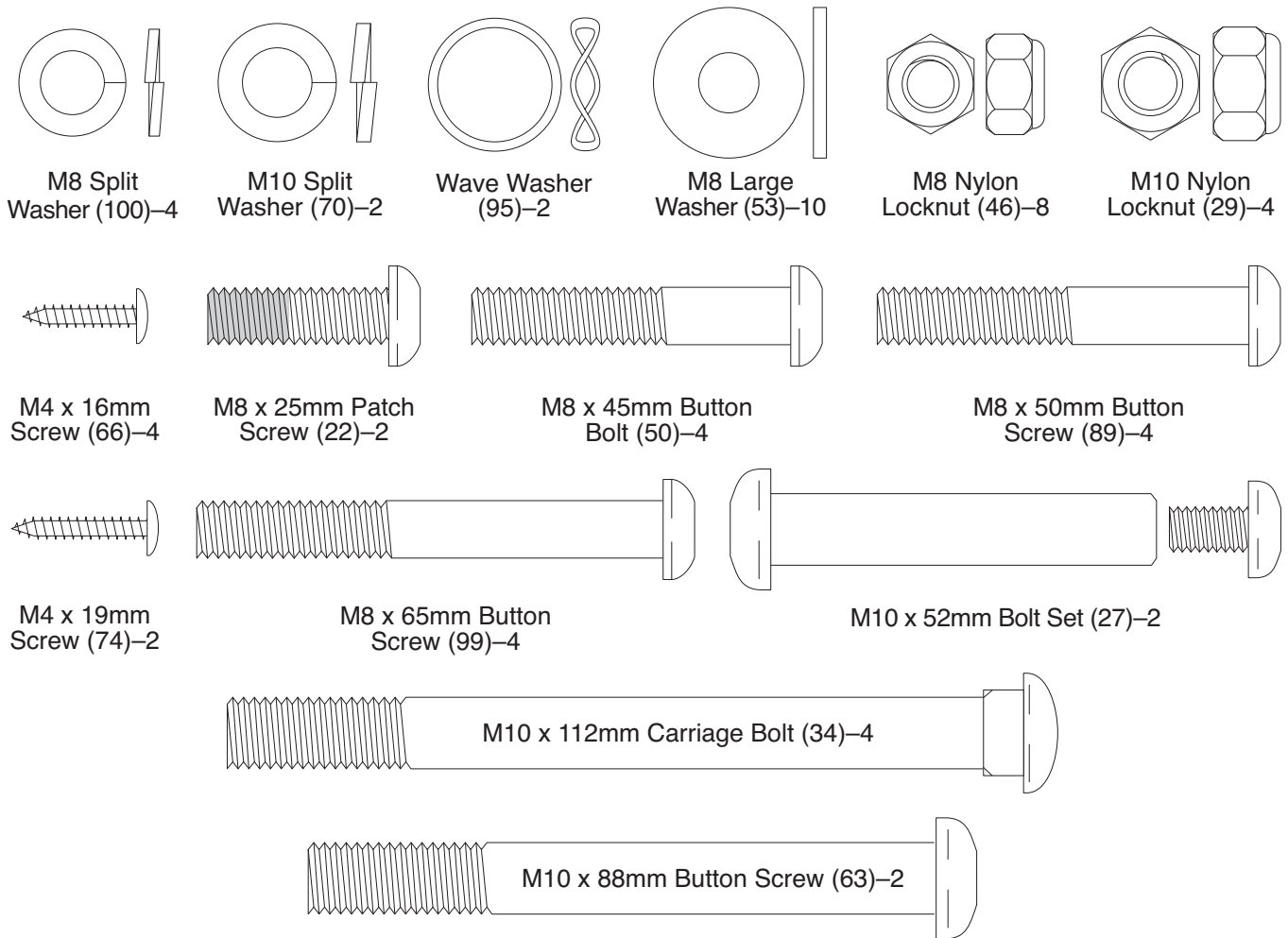

1. Identify the Front Stabilizer (3). While another person lifts the front of the Frame (1), attach the Front Stabilizer to the Frame with two M10 x 112mm Carriage Bolts (34) and two M10 Nylon Locknuts (29). **Make sure that the Front Stabilizer is turned so the Wheels (32) are not touching the floor.**

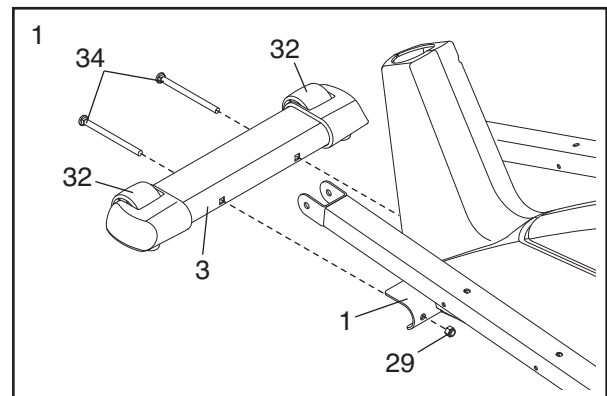

2. While another person lifts the back of the Frame (1), attach the Rear Stabilizer (4) to the Frame with two M10 x 112mm Carriage Bolts (34) and two M10 Nylon Locknuts (29).

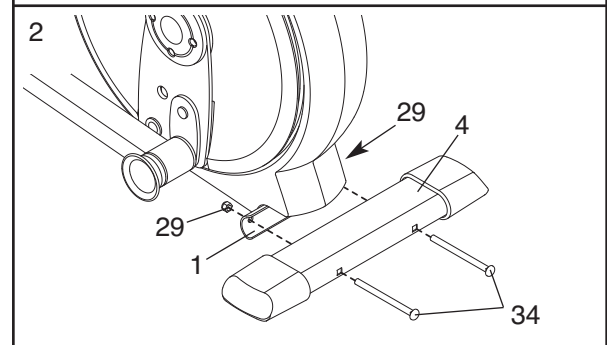

3. While another person holds the Upright (2) in the position shown, connect the Upper Wire Harness (86) to the Lower Wire Harness (87). **Carefully pull the upper end of the Upper Wire Harness to remove any slack. While holding the upper end of the Upper Wire Harness, insert the Upright into the Frame (1). Do not pinch the Wire Harnesses.**

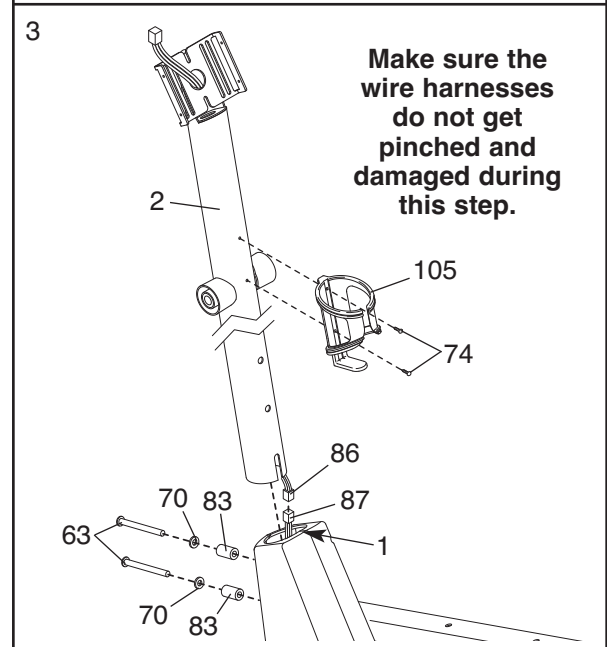

Slide an M10 Split Washer (70) and a Frame Spacer (83) onto each of the two M10 x 88mm Button Screws (63). Insert the Button Screws into the Frame (1) and the Upright (2). **Make sure that the concave ends of the Frame Spacers are facing the Frame. Do not tighten the Button Screws yet.**

Attach the Water Bottle Holder (105) to the Upright (2) with two M4 x 19mm Screws (74).

4. The Console (5) requires four 1.5V "D" batteries (not included); alkaline batteries are recommended. Remove the two battery covers from the Console. Next, insert four batteries into the battery compartments. **Make sure that the batteries are oriented as shown by the diagrams inside of the battery compartments.** Then, reattach the battery covers to the Console.

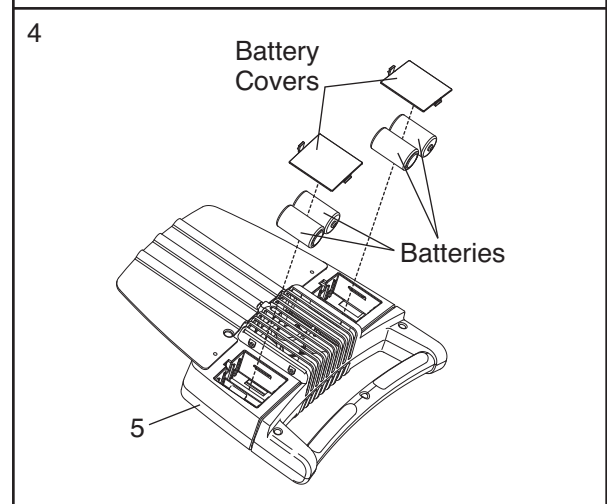

- While another person holds the Console (5) near the Upright (2), connect the wire harness on the Console to the Upper Wire Harness (86). Insert the excess wire harness into the Upright. Next, attach the Console to the Upright with four M4 x 16mm Screws (66). **Be careful to avoid pinching the wire harnesses.**

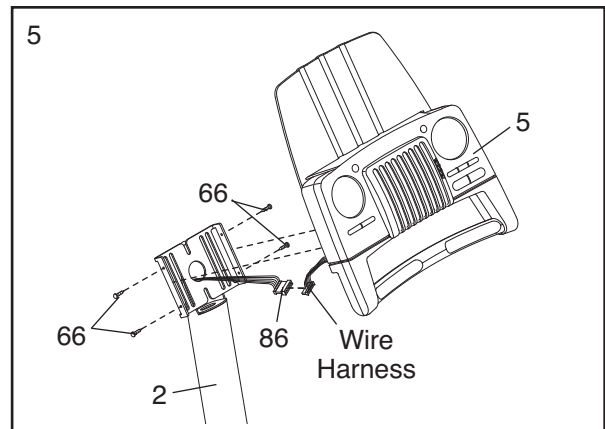

- Identify the Left Handlebar (9), which is marked with a sticker. Insert the Left Handlebar into one of the Handlebar Legs (79); **make sure that the Handlebar Leg is turned so the hexagonal holes are on the indicated side.** Attach the Left Handlebar to the Handlebar Leg with two M8 x 45mm Button Bolts (50) and two M8 Nylon Locknuts (46). **Make sure that the Nylon Locknuts are inside of the hexagonal holes. Do not tighten the Button Bolts yet.**

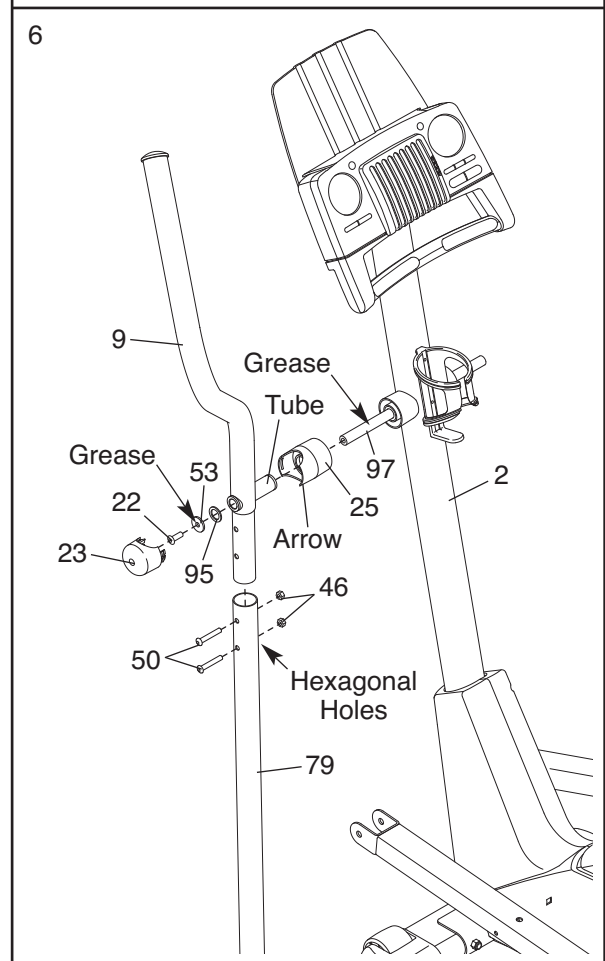

Apply a generous amount of the included grease to the Pivot Axle (97) and to the two M8 Large Washers (53). Next, insert the Pivot Axle into the Upright (2) and center it. Reapply grease to both ends of the Pivot Axle.

Slide a Handlebar Spacer (25) onto the short tube on the Left Handlebar (9), and rotate the Handlebar Spacer so the small arrow is pointing toward the floor. Next, slide the Left Handlebar onto the left end of the Pivot Axle (97). Finger tighten an M8 x 25mm Patch Screw (22) with an M8 Large Washer (53) and a Wave Washer (95) into the end of the Pivot Axle. Then, press the small tabs on a Handlebar Cap (23) into the Handlebar Spacer.

Assemble the Right Handlebar (not shown) and the other Handlebar Leg (not shown) in the same way.

Tighten both M8 x 25mm Patch Screws (22) at the same time.

- Apply a thin film of grease to the shaft of an M10 x 52mm Bolt Set (27) and to the surfaces of the two Leg Bushings (28) in the left Handlebar Leg (79).

Next, attach the left Handlebar Leg (79) to the Left Pedal Arm (14) with the M10 x 52mm Bolt Set (27). **Do not overtighten the Bolt Set; the left Handlebar Leg must be able to pivot freely.**

Attach the right Handlebar Leg (79) to the Right Pedal Arm (103) in the same way.

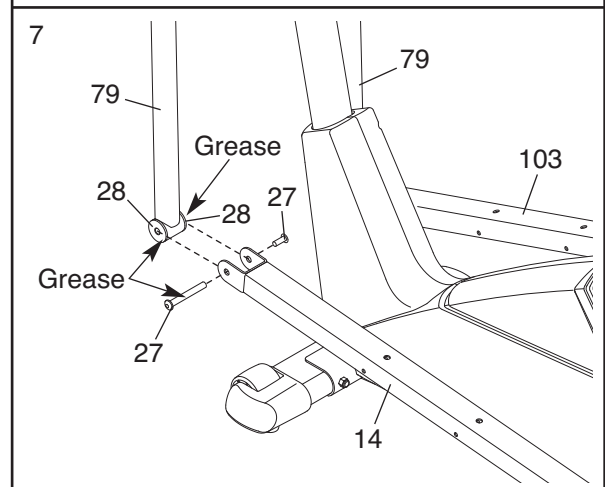

See step 3. Tighten the M10 x 88mm Button Screws (63). See step 6. Tighten the M8 x 45mm Button Bolts (50) in the Handlebar Legs (79).

8. Attach a Pedal Bracket (16) to the Left Pedal Arm (14) with two M8 x 65mm Button Screws (99), two M8 Large Washers (53), and two M8 Nylon Locknuts (46).

Identify the Left Pedal (13). Attach the Left Pedal to the Left Pedal Arm (14) with two M8 x 50mm Button Screws (89), two M8 Split Washers (100) and two M8 Large Washers (53).

Attach the other Pedal Bracket (not shown) and the Right Pedal (12) to the Right Pedal Arm (103) in the same way.

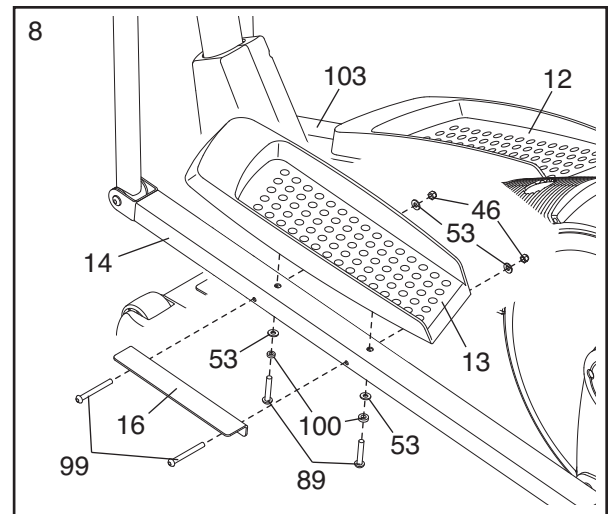

9. **Make sure that all parts of the elliptical exerciser are properly tightened.** Note: Some hardware may be left over after assembly is completed. To protect the floor or carpet from damage, place a mat under the elliptical exerciser.

HOW TO USE THE ELLIPTICAL EXERCISER

HOW TO EXERCISE ON THE ELLIPTICAL EXERCISER

To mount the elliptical exerciser, hold the handgrip pulse sensor and step onto the pedal that is in the lowest position. Next, step onto the other pedal. Push the pedals until they begin to move with a continuous motion. **Note: The pedal disks can turn in either direction. It is recommended that you move the pedal disks in the direction shown by the arrow below; however, for variety, you can turn the pedal disks in the opposite direction.**

To dismount the elliptical exerciser, wait until the pedals come to a complete stop. **Note: The elliptical exerciser does not have a free wheel; the pedals will continue to move until the flywheel stops.** When the pedals are stationary, step off the highest pedal first. Then, step off the lowest pedal.

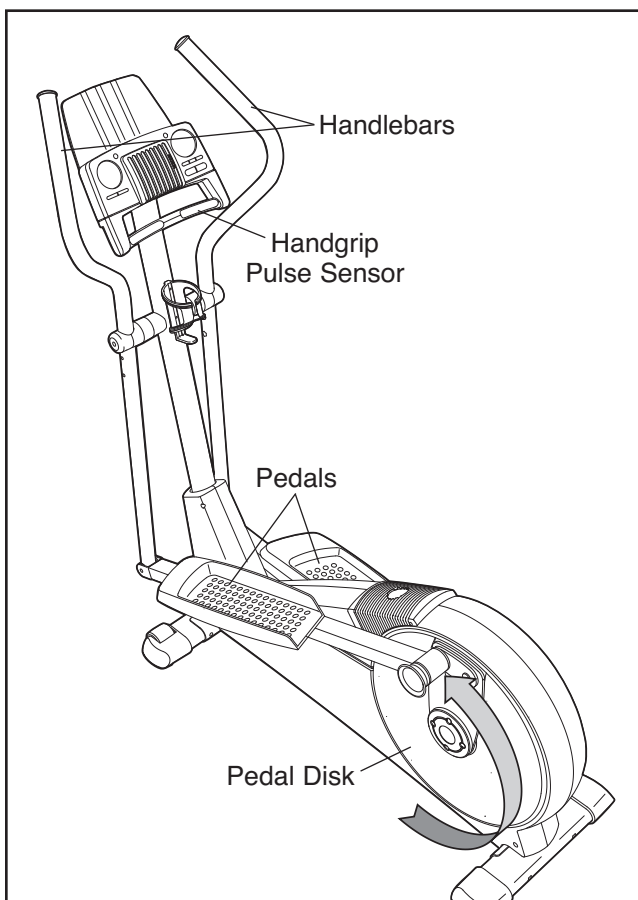

HOW TO USE THE HANDLEBARS

The handlebars are designed to add upper-body exercise to your workouts. Push and pull the handlebars as you exercise to work your arms, shoulders, and back.

To exercise only your lower body, hold the handgrip pulse sensor as you exercise.

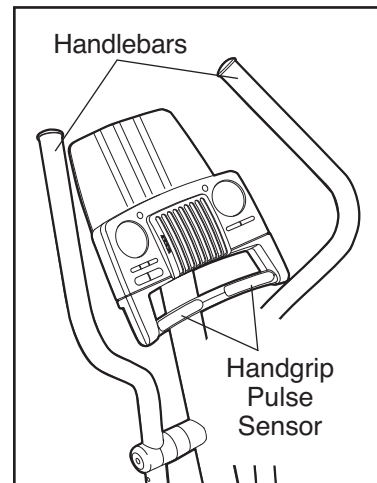

HOW TO ADJUST THE STRIDE OF THE ELLIPTICAL EXERCISER

To adjust the stride of the elliptical exerciser, first pull one of the adjustment knobs until the adjustment bracket can be pivoted freely. Pivot the adjustment bracket until the adjustment knob is aligned with one of the three holes in the crank arm, and gently release the knob. Then, pivot the adjustment bracket back and forth slightly to make sure that the adjustment pin is engaged in one of the holes in the crank arm.

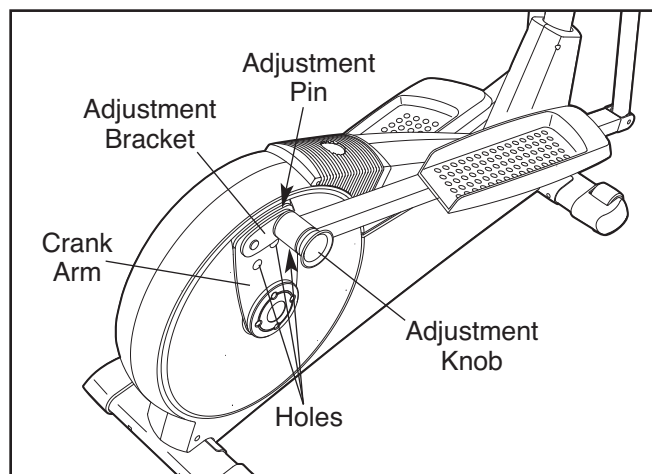

Adjust the other side of the elliptical exerciser in the same way.

CONSOLE DIAGRAM

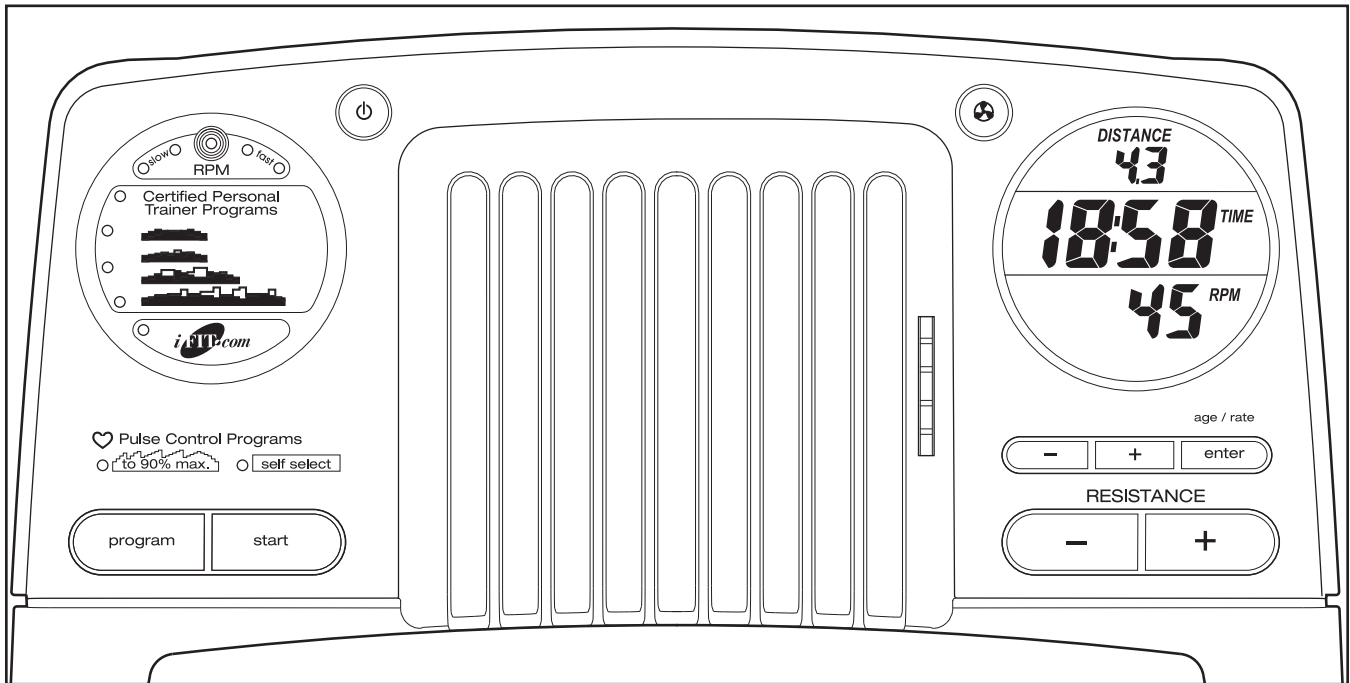

FEATURES OF THE CONSOLE

The advanced console offers a selection of features designed to make your workouts more enjoyable and effective. When the manual mode of the console is selected, the resistance of the pedals can be changed with the touch of a button. As you pedal, the console will provide continuous exercise feedback. You can even measure your heart rate using the built-in hand-grip pulse sensor.

The console also offers four preset programs. Each program automatically changes the resistance of the pedals and prompts you to increase or decrease your pace as it guides you through an effective workout.

In addition, the console features two pulse programs that change the resistance of the pedals and prompt you to vary your pace to keep your heart rate near a target heart rate while you exercise.

The console also features iFIT.com interactive technology. Having iFIT.com technology is like having a per-

sonal trainer in your home. Using a stereo audio cable (available at electronics stores), you can connect the elliptical exerciser to your home stereo, portable stereo, computer, or VCR and play special iFIT.com CD and video programs (iFIT.com CDs and videocassettes are available separately). iFIT.com CD and video programs automatically control the resistance of the pedals and prompt you to vary your pace as a personal trainer coaches you through every step of your workout. High-energy music provides added motivation. **To purchase iFIT.com CDs and videocassettes, call toll-free 1-888-533-1333.**

With the elliptical exerciser connected to your computer, you can also go to our Web site at www.iFIT.com and access programs directly from the internet. **Explore www.iFIT.com for more information.**

To use the manual mode of the console, see page 11. **To use a preset program**, see page 13. **To use a pulse program**, see page 13. **To use an iFIT.com CD or video program**, see page 17. **To use a program directly from our Web site**, see page 18.

HOW TO USE THE MANUAL MODE

1 Turn on the console.

To turn on the console, press the On/Reset button or begin pedaling. Note: If there are sheets of clear plastic on the face of the console, remove the plastic.

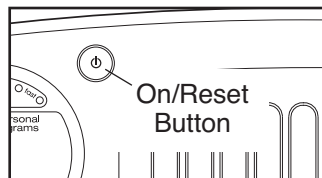

2 Select the manual mode.

When the power is turned on, the manual mode will be selected. If you have selected a program or the iFIT.com mode, reselect the manual mode by pressing the Program button repeatedly until no indicators are lit.



3 Begin pedaling and change the resistance of the pedals as desired.

As you pedal, change the resistance of the pedals by pressing the Resistance buttons. There are ten resistance levels—level 10 is the most challenging. Note: After the buttons are pressed, it will take a moment for the pedals to reach the selected resistance level.



4 Monitor your progress with the display.

The upper part of the display will show the distance you have pedaled and the approximate number of calories you have burned. The display will change from one number to the other every few seconds. The upper part of the display will also show your heart rate when you use the handgrip pulse sensor (see step 5 on page 12).

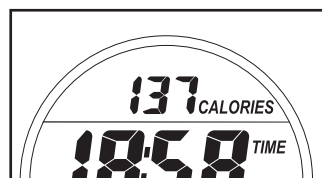

The center of the display will show the elapsed time, your pedaling pace in minutes per mile, and the approximate number of grams of carbs you have burned. The display will change from one number to the next every few seconds. Note: When a program is selected (except for the self select program), the display will show the time remaining in the program instead of the elapsed time.

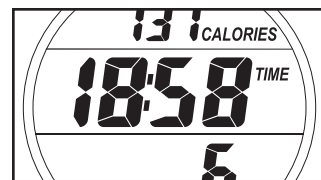

The lower part of the display will show your pedaling pace in revolutions per minute (RPM), your pedaling speed, and the resistance level of the pedals. The display will change from one number to the next every few seconds.



To reset the display, press the On/Reset button.

Note: The console can show speed and distance in either miles or kilometers. The letters MPH or KM/H will appear in the lower part of the display to show which unit of measurement is selected. To change the unit of measurement, first hold down the Program button for a few seconds. An E (for English) or an M (for metric) will appear in the lower part of the display. Press the Resistance + button to change the unit of measurement. Note: When the batteries are replaced, it may be necessary to reselect the desired unit of measurement.



While you are selecting a unit of measurement, you can also select a backlight mode. The "On" mode keeps the backlight on while the console is on. The "Off" mode turns the backlight off. To conserve the batteries, the "Auto" mode keeps the backlight on only while you are exercising. Press the Resistance – button to change the backlight mode if desired. Then, press the On/Reset button.



5 Measure your heart rate if desired.

If there are thin sheets of plastic on the metal contacts on the handgrip pulse sensor, peel off the plastic. Place your hands on

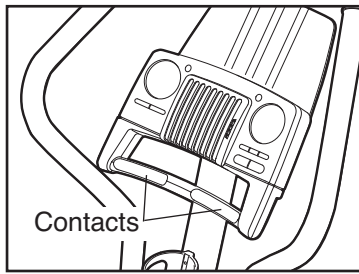

the handgrip pulse sensor, with your palms on the contacts closest to you and your fingers touching the contacts on the opposite side of the handgrip pulse sensor. **Avoid moving your hands.** When your pulse is detected, the heart-shaped indicator in the upper part of the display will begin to flash each time your heart beats. After a moment your heart rate will be shown.

For the most accurate heart rate reading, continue to hold the handgrips for about 30 seconds.

Note: If you continue to hold the handgrip pulse sensor, the display will show your heart rate for up to 30 seconds. The display will then show your heart rate along with the other modes.

If your heart rate is not shown, make sure that your hands are positioned as described. Avoid moving your hands excessively or squeezing the metal contacts too tightly. For optimal performance, periodically clean the metal contacts using a soft cloth; **never use alcohol, abrasives, or chemicals.**

6 Turn on the fan if desired.

To turn on the fan at low speed, press the fan button. To turn on the fan at high speed, press the fan button a second time. To turn off the fan, press the fan button a third time. Note:

If the fan is turned on but the pedals are not moved for thirty seconds, the fan will automatically turn off.

Rotate the thumb wheel on the right side of the fan to adjust the angle of the fan.

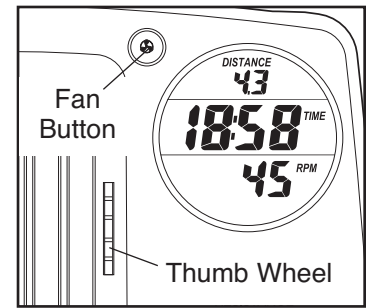

7 When you are finished exercising, the console will automatically turn off.

If the pedals are not moved for a few seconds, a series of tones will sound, the time will begin to flash, and the console will pause.

If the pedals are not moved for a few minutes, the console will turn off and the display will be reset.

HOW TO USE A PRESET PROGRAM

1 Turn on the console.

See step 1 on page 11.

2 Select one of the preset programs.

To select a preset program, press the Program button repeatedly until one of the four preset program indicators lights.



3 Press the Start button or begin pedaling to start the program.

Each preset program consists of several one-minute periods. One resistance setting and one target pace are programmed for each period. Note: The same resistance setting and/or target pace may be programmed for two or more consecutive periods, as shown by the four profiles near the program indicators.

At the end of each period of the program, a series of tones will sound and the time will flash in the display. The resistance of the pedals will then automatically change if a different resistance setting is programmed for the next period. Note: If the resistance level is too high or too low, you can change it by pressing the Resistance buttons. However, when the current period ends, the resistance of the pedals will automatically change if a different resistance setting is programmed for the next period.

During the program, the center of the display will show the time remaining in the program. If you stop pedaling for several seconds, the program will pause and the time will flash in the display. To restart the program, simply resume pedaling.

4 Use the pace guide to pace your exercise.

Throughout the program, the pace guide above the program indicators will prompt you to increase or decrease your pedaling pace. When one of the

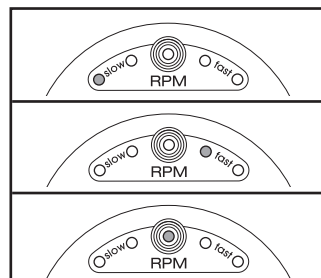

indicators on the left side of the pace guide lights, increase your pace; when one of the indicators on the right side lights, decrease your pace. When the center indicator lights, maintain your current pace. **Important: The pace guide is intended only to provide a goal. Make sure to pedal at a pace that is comfortable for you.**

5 Monitor your progress with the display.

See step 4 on page 11.

6 Measure your heart rate if desired.

See step 5 on page 12.

7 Turn on the fan if desired.

See step 6 on page 12.

8 When you are finished exercising, the console will automatically turn off.

See step 7 on page 12.

HOW TO USE A PULSE PROGRAM

Pulse program 1 is designed to keep your heart rate between 65% and 90% of your *estimated maximum heart rate* during your workout. (Your maximum heart rate is estimated by subtracting your age from 220. For example, if you are 25 years old, your estimated maximum heart rate is 195 beats per minute.) Pulse program 2 is designed to keep your heart rate near a target heart rate that you select.

Follow the steps below to use a pulse program.

1 Turn on the console.

See step 1 on page 11.

2 Select one of the pulse programs.

To select a pulse program, press the Program button repeatedly until one of the two pulse program indicators lights.

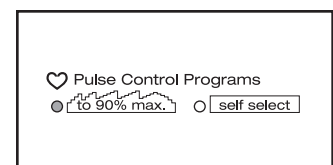

3 Enter your age or a target heart rate.

If pulse program 1 is selected, the word "AGE" will flash in the lower part of the display. You must enter

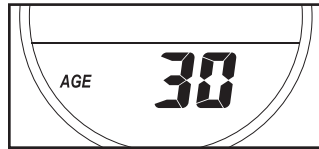

your age to use this program. If you have already entered your age, press the Enter button and go to step 4. If you have not entered your age, press the + or – button beside the Enter button to enter your age, and then press the Enter button. Note: Once you have entered your age, it will be saved in memory.

If pulse program 2 is selected, the word "RATE" will flash in the lower part of the display. You must enter a

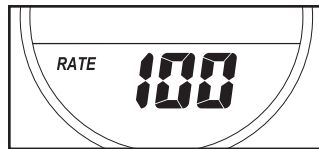

target heart rate to use this program. (See the chart on page 20 for heart rate guidelines.) If you have already entered a target heart rate, press the Enter button and go to step 4. If you have not entered a target heart rate, press the + or – button beside the Enter button, and then press the Enter button. Note: Once you have entered a target heart rate, it will be saved in memory.

4 Hold the handgrip pulse sensor.

It is not necessary to hold the handgrips continuously during a pulse program; however, you must hold the handgrips frequently for the program to operate properly. **Each time you hold the handgrips, keep your hands on the metal contacts for at least 30 seconds.** Note: When you are not holding the handgrips, the letters PLS will appear in the large display instead of your heart rate.

5 Press the Start button or begin pedaling to start the program.

Program 1 consists of 30 one-minute periods. One target heart rate is programmed for each period. (The same target heart rate may be programmed for two or more consecutive periods.) **Program 2** is sixty minutes long (you may choose to use only part of the program). The same target heart rate is programmed for the entire program.

When only three seconds remain in the first period of the program, a series of tones will sound and the time will flash in the display.

During the program, the console will regularly compare your heart rate to the target heart rate. If your heart rate is too far below or above the target heart rate, the resistance of the pedals will automatically increase or decrease to bring your heart rate closer to the target heart rate. Note: If the resistance level is too high or too low, you can change it by pressing the Resistance buttons. However, when the console compares your heart rate to the target heart rate, the resistance may automatically change.

As you pedal, the pace guide will prompt you to increase or decrease your pedaling pace. When one of the indicators on the left side of the pace guide lights, increase

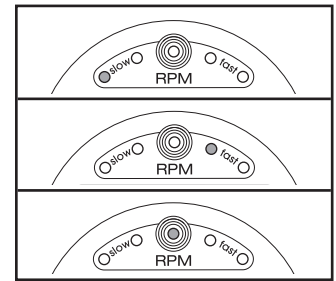

your pace; when one of the indicators on the right side lights, decrease your pace. When the center indicator lights, maintain your current pace.

Important: The target heart rate is intended only to provide a goal. Make sure to pedal at a pace that is comfortable for you.

The program will continue until no time remains in the display. If you stop pedaling for several seconds, the program will pause and the time will flash in the display. To restart the program, simply resume pedaling.

6 Follow your progress with the display.

See step 4 on page 11.

7 Turn on the fan if desired.

See step 6 on page 12.

8 When you are finished exercising, the console will automatically turn off.

See step 7 on page 12.

HOW TO CONNECT YOUR CD PLAYER, VCR, OR COMPUTER

To use **iFIT.com** CDs, the elliptical exerciser must be connected to your portable CD player, portable stereo, home stereo, or computer with CD player. See pages 15 and 16 for connecting instructions. To use **iFIT.com** videocassettes, the elliptical exerciser must be connected to your VCR. See page 17 for connecting instructions. To use **iFIT.com** programs directly from our **Web site**, the elliptical exerciser must be connected to your computer. See page 16.

HOW TO CONNECT YOUR PORTABLE CD PLAYER

Note: If your CD player has separate **LINE OUT** and **PHONES** jacks, see instruction A below. If your CD player has only one jack, see instruction B.

- A. Plug one end of a 1/8" to 1/8" stereo audio cable (available at electronics stores) into the jack beneath the console. Plug the other end of the cable into the **LINE OUT** jack on your CD player. Plug your headphones into the **PHONES** jack.

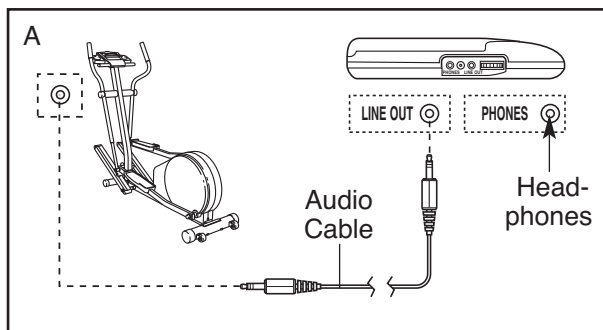

- B. Plug one end of a 1/8" to 1/8" stereo audio cable (available at electronics stores) into the jack beneath the console. Plug the other end of the cable into a 1/8" Y-adaptor (available at electronics stores). Plug the Y-adaptor into the **PHONES** jack on your CD player. Plug your headphones into the other side of the Y-adaptor.

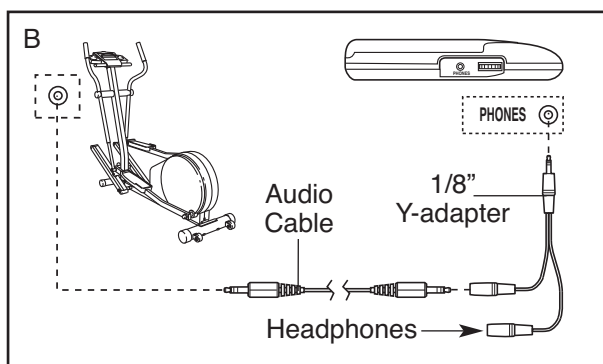

HOW TO CONNECT YOUR PORTABLE STEREO

Note: If your stereo has an **RCA-type AUDIO OUT** jack, see instruction A below. If your stereo has a 1/8" **LINE OUT** jack, see instruction B. If your stereo has only a **PHONES** jack, see instruction C.

- A. Plug one end of a 1/8" to RCA stereo audio cable (available at electronics stores) into the jack beneath the console. Plug the other end of the cable into the **AUDIO OUT** jack on your stereo.

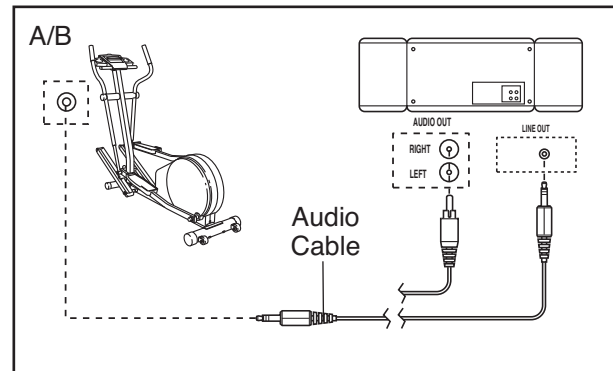

- B. See the drawing above. Plug one end of a 1/8" to 1/8" stereo audio cable (available at electronics stores) into the jack beneath the console. Plug the other end of the cable into the **LINE OUT** jack on your stereo.

- C. Plug one end of a 1/8" to 1/8" stereo audio cable (available at electronics stores) into the jack beneath the console. Plug the other end of the cable into a 1/8" Y-adaptor (available at electronics stores). Plug the Y-adaptor into the **PHONES** jack on your stereo. Plug your headphones into the other side of the Y-adaptor.

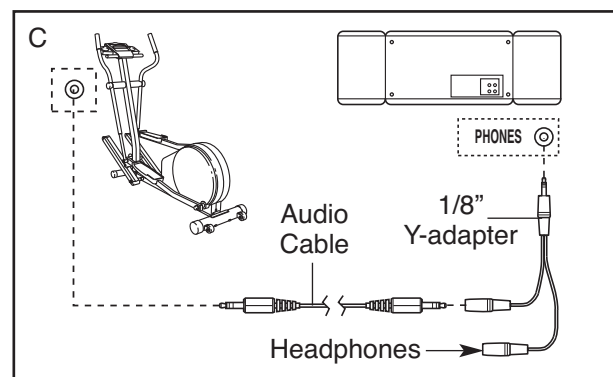

HOW TO CONNECT YOUR HOME STEREO

Note: If your stereo has an unused **LINE OUT** jack, see instruction **A** below. If the **LINE OUT** jack is being used, see instruction **B**.

- A. Plug one end of a 1/8" to RCA stereo audio cable (available at electronics stores) into the jack beneath the console. Plug the other end of the cable into the **LINE OUT** jack on your stereo.

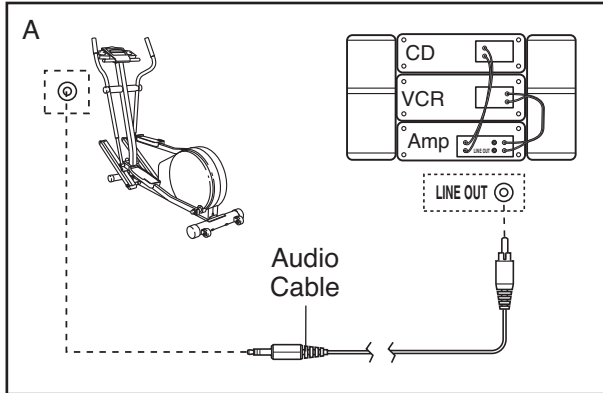

- B. Plug one end of a 1/8" to RCA stereo audio cable (available at electronics stores) into the jack beneath the console. Plug the other end of the cable into an RCA Y-adapter (available at electronics stores). Next, remove the wire that is currently plugged into the **LINE OUT** jack on your stereo and plug the wire into the unused side of the Y-adapter. Plug the Y-adapter into the **LINE OUT** jack on your stereo.

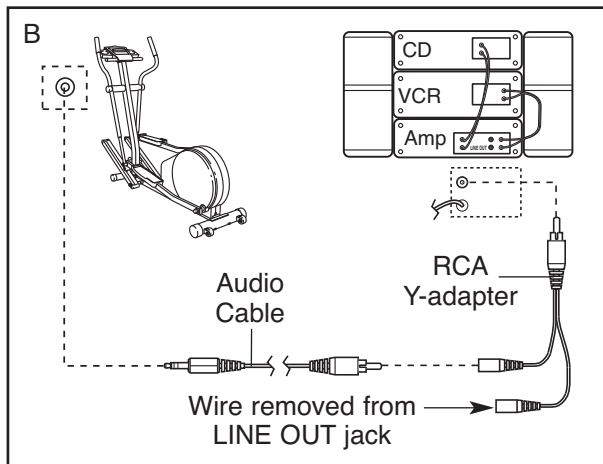

HOW TO CONNECT YOUR COMPUTER

Note: If your computer has a 1/8" **LINE OUT** jack, see instruction **A**. If your computer has only a **PHONES** jack, see instruction **B**.

- A. Plug one end of a 1/8" to 1/8" stereo audio cable (available at electronics stores) into the jack beneath the console. Plug the other end of the cable into the **LINE OUT** jack on your computer.

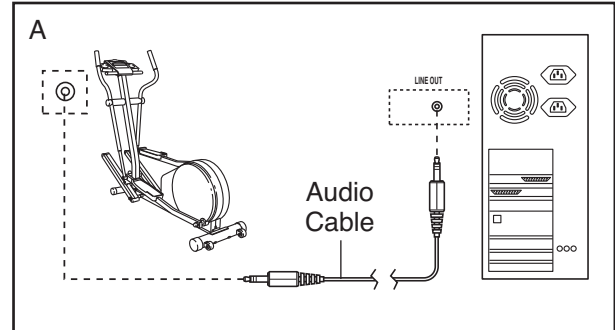

- B. Plug one end of a 1/8" to 1/8" stereo audio cable (available at electronics stores) into the jack beneath the console. Plug the other end of the cable into a 1/8" Y-adapter (available at electronics stores). Plug the Y-adapter into the **PHONES** jack on your computer. Plug your headphones or speakers into the other side of the Y-adapter.

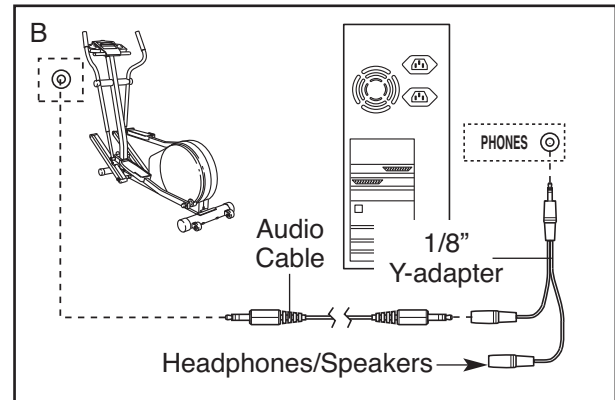

HOW TO CONNECT YOUR VCR

Note: If your VCR has an unused AUDIO OUT jack, see instruction A below. If the AUDIO OUT jack is being used, see instruction B. If you have a TV with a built-in VCR, see instruction B. If your VCR is connected to your home stereo, see **HOW TO CONNECT YOUR HOME STEREO** on page 16.

- A. Plug one end of a 1/8" to RCA stereo audio cable (available at electronics stores) into the jack beneath the console. Plug the other end of the cable into the AUDIO OUT jack on your VCR.

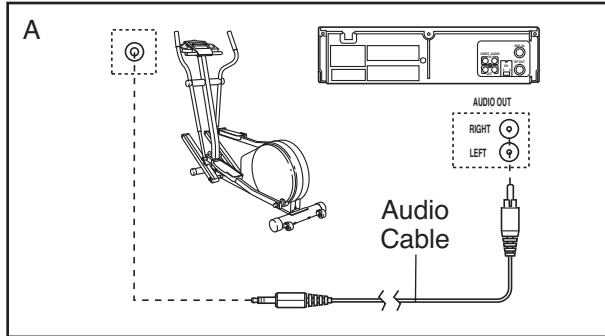

- B. Plug one end of a 1/8" to RCA stereo audio cable (available at electronics stores) into the jack beneath the console. Plug the other end of the cable into an RCA Y-adapter (available at electronics stores). Next, remove the wire that is currently plugged into the AUDIO OUT jack on your VCR and plug the wire into the unused side of the Y-adapter. Plug the Y-adapter into the AUDIO OUT jack on your VCR.

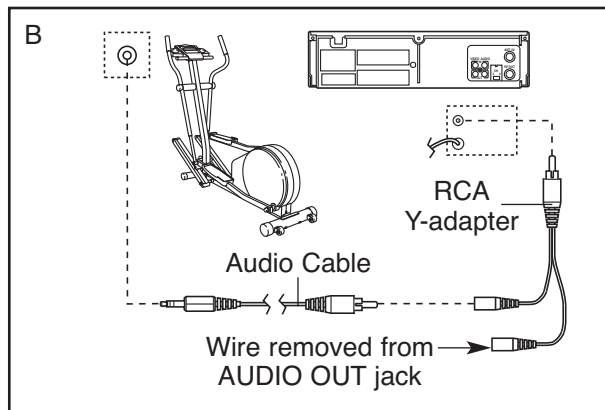

HOW TO USE AN iFIT.COM CD AND VIDEO PROGRAM

To use iFIT.com CDs or videocassettes, the elliptical exerciser must be connected to your portable CD player, portable stereo, home stereo, computer with CD player, or VCR. See **HOW TO CONNECT YOUR CD PLAYER, VCR, OR COMPUTER** on pages 15 to 17.

To purchase iFIT.com CDs and videocassettes, call toll-free 1-888-533-1333.

Follow the steps below to use an iFIT.com CD or video program.

1 Turn on the console.

See step 1 on page 11.

2 Select the iFIT.com mode.

To select the iFIT.com mode, press the Program button repeatedly until the iFIT.com indicator lights.

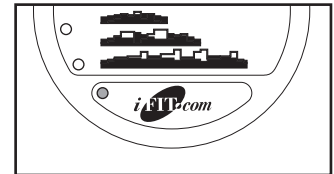

3 Insert the iFIT.com CD or videocassette.

If you are using an iFIT.com CD, insert the CD into your CD player. If you are using an iFIT.com videocassette, insert the videocassette into your VCR.

4 Press the play button on your CD player or VCR.

A moment after the play button is pressed, your personal trainer will begin guiding you through your workout. Simply follow your personal trainer's instructions.

The program will function in almost the same way as a preset program (see steps 3 and 4 on page 13). However, an electronic "chirping" sound will alert you when the resistance of the pedals and/or the pace guide is about to change.

Note: If the resistance of the pedals and/or the pace guide does not change when a “chirp” is heard:

- Make sure that the iFIT.com indicator is lit.
- Adjust the volume of your CD player or VCR. If the volume is too high or too low, the console may not detect the program signals.
- Make sure that the audio cable is properly connected and that it is fully plugged in.

5 Monitor your progress with the display.

See step 4 on page 11.

6 Measure your heart rate if desired.

See step 5 on page 12.

7 Turn on the fan if desired.

See step 6 on page 12.

8 When you are finished exercising, the console will automatically turn off.

See step 7 on page 12.

HOW TO USE PROGRAMS DIRECTLY FROM OUR WEB SITE

Our Web site at www.iFIT.com allows you to play iFIT.com programs directly from the internet. To use programs from our Web site, the elliptical exerciser must be connected to your home computer. See HOW TO CONNECT YOUR COMPUTER on page 16. In addition, you must have an internet connection and an internet service provider. A list of specific system requirements is found on our Web site.

Follow the steps at the right to use a program from our Web site.

1 Turn on the console.

See step 1 on page 11.

2 Select the iFIT.com mode.

See step 2 on page 17.

3 Go to your computer and start an internet connection.

4 Start your Web browser, if necessary, and go to our Web site at www.iFIT.com.

5 Follow the desired links on our Web site to select a program.

Read and follow the on-line instructions for using a program.

6 Follow the on-line instructions to start the program.

When you start the program, an on-screen countdown will begin.

7 Return to the elliptical exerciser and begin pedaling.

When the on-screen countdown ends, the program will begin. The program will function in almost the same way as a preset program (see steps 3 and 4 on page 13). However, an electronic “chirping” sound will alert you when the resistance of the pedals and/or the pace guide is about to change.

8 Monitor your progress with the display.

See step 4 on page 11.

9 Measure your heart rate if desired.

See step 5 on page 12.

10 Turn on the fan if desired.

See step 6 on page 12.

11 When you are finished exercising, the console will automatically turn off.

See step 7 on page 12.

MAINTENANCE AND TROUBLESHOOTING

Inspect and tighten all parts of the elliptical exerciser regularly. Replace any worn parts immediately.

To clean the elliptical exerciser, use a damp cloth and a small amount of mild soap. **Important: To avoid damage to the console, keep liquids away from the console and keep the console out of direct sunlight.**

BATTERY REPLACEMENT

If the console displays become dim, the batteries should be replaced; most console problems are the result of low batteries. See assembly step 4 on page 6 for replacement instructions.

HOW TO LEVEL THE ELLIPTICAL EXERCISER

After the elliptical exerciser has been moved to the location where it will be used, make sure that the ends of both stabilizers are touching the floor. If the elliptical exerciser

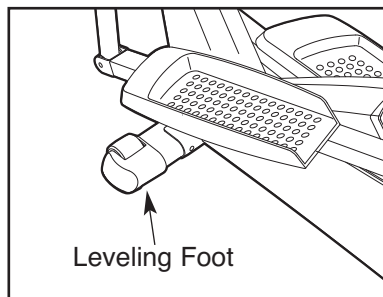

rocks slightly during use, turn one or both of the leveling feet under the front stabilizer until the rocking motion is eliminated.

HANDGRIP PULSE SENSOR TROUBLESHOOTING

- Avoid moving your hands while using the handgrip pulse sensor. Excessive movement may interfere with heart rate readings.
- Do not hold the metal contacts too tightly; doing so may interfere with heart rate readings.
- For the most accurate heart rate reading, hold the metal contacts for about 30 seconds.
- For optimal performance of the handgrip pulse sensor, keep the metal contacts clean. The contacts can be cleaned with a soft cloth—never use alcohol, abrasives, or chemicals.

CONDITIONING GUIDELINES

WARNING:



Before beginning this or any exercise program, consult your physician. This is especially important for persons over the age of 35 or persons with pre-existing health problems.

The pulse sensor is not a medical device. Various factors may affect the accuracy of heart rate readings. The pulse sensor is intended only as an exercise aid in determining heart rate trends in general.

The following guidelines will help you to plan your exercise program. Remember that proper nutrition and adequate rest are essential for successful results.

EXERCISE INTENSITY

Whether your goal is to burn fat or to strengthen your cardiovascular system, the key to achieving the desired results is to exercise with the proper intensity. The proper intensity level can be found by using your heart rate as a guide. The chart below shows recommended heart rates for fat burning, maximum fat burning, and cardiovascular (aerobic) exercise.

165	155	145	140	130	125	115	
145	138	130	125	118	110	103	
125	120	115	110	105	95	90	
<hr/>							
20	30	40	50	60	70	80	

To find the proper heart rate for you, first find your age at the bottom of the chart (ages are rounded off to the nearest ten years). Next, find the three numbers above your age. The three numbers are your “training zone.” The lower two numbers are recommended heart rates for fat burning; the highest number is the recommended heart rate for aerobic exercise.

Fat Burning

To burn fat effectively, you must exercise at a relatively low intensity level for a sustained period of time.

During the first few minutes of exercise, your body uses easily accessible *carbohydrate* calories for energy. Only after the first few minutes of exercise does your body begin to use stored *fat* calories for energy. If your goal is to burn fat, adjust the intensity of your exercise until your heart rate is near the lowest number in your training zone as you exercise.

For maximum fat burning, adjust the intensity of your exercise until your heart rate is near the middle number in your training zone as you exercise.

Aerobic Exercise

If your goal is to strengthen your cardiovascular system, your exercise must be “aerobic.” Aerobic exercise is activity that requires large amounts of oxygen for prolonged periods of time. This increases the demand on the heart to pump blood to the muscles, and on the lungs to oxygenate the blood. For aerobic exercise, adjust the intensity of your exercise until your heart rate is near the highest number in your training zone as you exercise.

WORKOUT GUIDELINES

Each workout should include the following three parts:

A warm-up, consisting of 5 to 10 minutes of stretching and light exercise. A proper warm-up increases your body temperature, heart rate, and circulation in preparation for exercise.

Training zone exercise, consisting of 20 to 30 minutes of exercising with your heart rate in your training zone. Note: During the first few weeks of your exercise program, do not keep your heart rate in your training zone for longer than 20 minutes.

A cool-down, with 5 to 10 minutes of stretching. This will increase the flexibility of your muscles and will help to prevent post-exercise problems.

EXERCISE FREQUENCY

To maintain or improve your condition, complete three workouts each week, with at least one day of rest between workouts. After a few months of regular exercise, you may complete up to five workouts each week if desired. The key to success is to make exercise a regular and enjoyable part of your everyday life.

PART LIST—Model No. 831.28543.0

R0605A

Key No.	Qty.	Description	Key No.	Qty.	Description
1	1	Frame	56	1	Belt
2	1	Upright	57	2	Hub
3	1	Front Stabilizer	58	2	Hub Spacer
4	1	Rear Stabilizer	59	4	M6 Nylon Locknut
5	1	Console	60	4	M6 Nut
6	1	Left Side Shield	61	4	M5 Nylon Locknut
7	1	Right Side Shield	62	4	M5 x 12mm Bolt
8	2	Pedal Disc	63	2	M10 x 88mm Button Screw
9	1	Left Handlebar	64	2	M4 x 6mm Self-tapping Screw
10	1	Right Handlebar	65	2	Adjustment Bracket Screw
11	2	Foam Grip	66	8	M4 x 16mm Screw
12	1	Right Pedal	67	4	M4 x 25mm Screw
13	1	Left Pedal	68	1	Right Front Endcap
14	1	Left Pedal Arm	69	1	Reed Switch Clamp
15	1	Book Rack	70	2	M10 Split Washer
16	2	Pedal Bracket	71	2	Handlebar Endcap
17	2	Adjustment Pin	72	2	Leveling Foot
18	4	Pedal Arm Bushing	73	1	M5 x 16mm Screw
19	2	Adjustment Spring	74	10	M4 x 19mm Screw
20	2	Adjustment Bracket	75	2	M6 Eyebolt
21	2	Snap Ring	76	1	Resistance Spring
22	2	M8 x 25mm Patch Screw	77	1	Reed Switch
23	2	Handlebar Cap	78	1	Reed Switch Bracket
24	6	Handlebar Bushing	79	2	Handlebar Leg
25	2	Handlebar Spacer	80	1	Side Shield Cover
26	2	Upright Spacer	81	1	“U” Bracket
27	2	M10 x 52mm Bolt Set	82	8	Cover Screw
28	4	Leg Bushing	83	2	Frame Spacer
29	4	M10 Nylon Locknut	84	4	M4 x 12mm Round Head Screw
30	1	Upright Bushing	85	1	Resistance Cable
31	1	Left Front Endcap	86	1	Upper Wire Harness
32	2	Wheel	87	1	Lower Wire Harness
33	2	M6 x 72mm Button Screw	88	2	Pedal Arm Sleeve
34	4	M10 x 112mm Carriage Bolt	89	4	M8 x 50mm Button Screw
35	2	Rear Stabilizer Endcap	90	4	Motor Washer
36	1	Left Crank Arm	91	2	Short Hub Spacer
37	1	Pulley	92	2	Inner Pedal Arm Sleeve
38	1	Right Crank Arm	93	3	M6 Washer
39	1	Crank	94	2	Large Snap Ring
40	2	Crank Bearing	95	2	Wave Washer
41	1	Flywheel	96	2	M3 x 12mm Screw
42	2	Flywheel Bearing	97	1	Pivot Axle
43	1	Magnet	98	4	M8 Jam Nut
44	1	Flywheel Axle	99	4	M8 x 65mm Button Screw
45	2	Adjustment Knob	100	4	M8 Split Washer
46	11	M8 Nylon Locknut	101	4	M8 x 45mm Button Screw
47	2	Crank Screw	102	4	M8 x 20mm Button Screw
48	2	Hub Cover	103	1	Right Pedal Arm
49	1	M6 x 25mm Bolt	104	2	M8 Washer
50	4	M8 x 45mm Button Bolt	105	1	Water Bottle Holder
51	4	M6 x 18mm Button Bolt	106	2	Pin Spacer
52	1	“C” Magnet Bracket	107	2	Pin Collar
53	10	M8 Large Washer	#	2	Allen Wrench
54	1	“C” Magnet	#	1	Grease
55	1	Motor	#	1	User’s Manual

Note: “#” indicates a non-illustrated part. Specifications are subject to change without notice. **If a part is missing, call toll-free 1-888-533-1333.** See the back cover of this manual for information about ordering replacement parts.

EXPLODED DRAWING A—Model No. 831.28543.0

R0605A

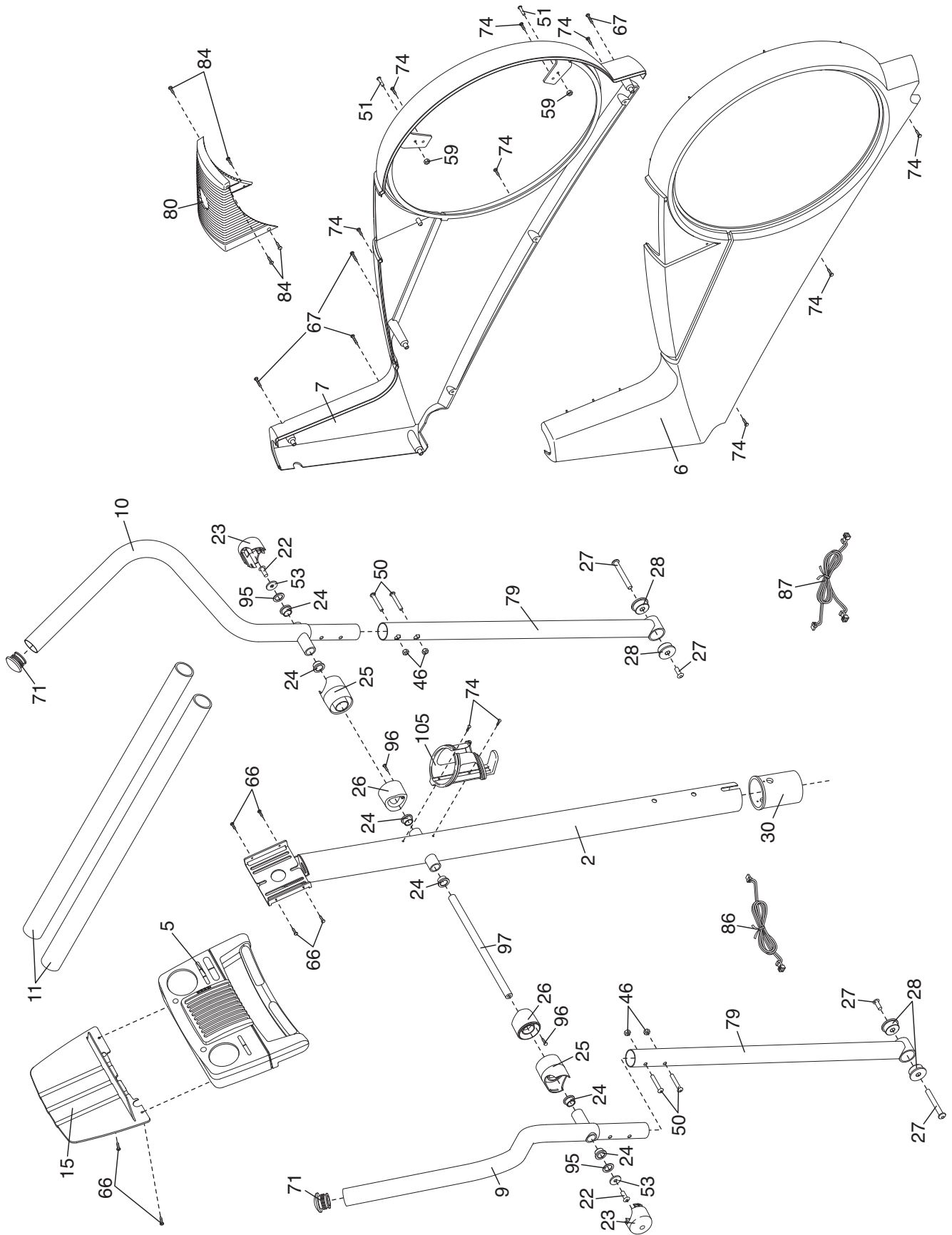

EXPLODED DRAWING B—Model No. 831.28543.0

R0605A

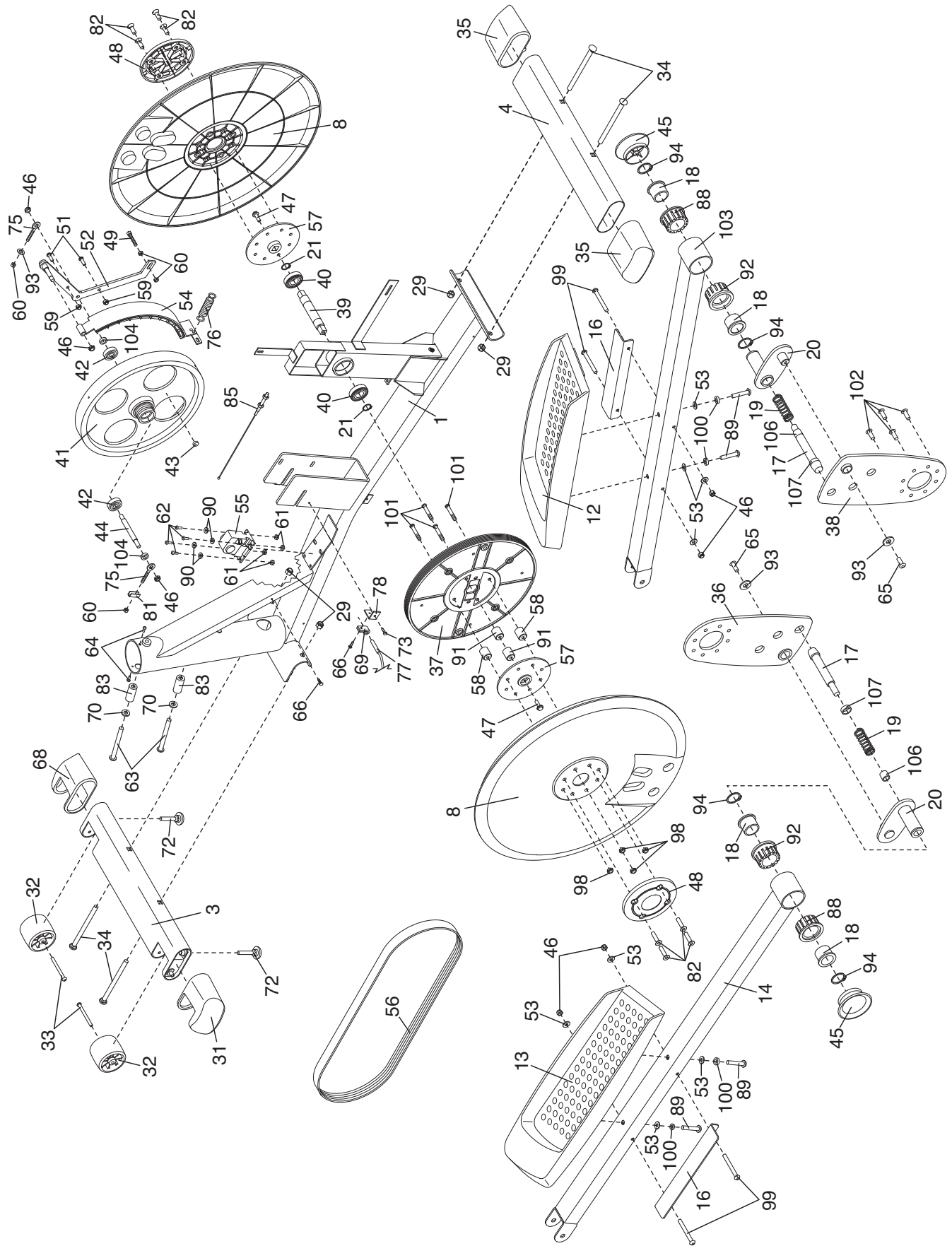

Get it fixed, at your home or ours!

Your Home

For repair – **in your home** – of **all** major brand appliances, lawn and garden equipment, or heating and cooling systems, **no matter who made it, no matter who sold it!**

For the replacement parts, accessories, and user's manuals that you need to do-it-yourself.

For Sears professional installation of home appliances and items like garage door openers and water heaters.

1-800-4-MY-HOME®

(1-800-469-4663)

www.sears.com

Anytime, day or night

(U.S.A. and Canada)

www.sears.ca

Our Home

For repair of carry-in products like vacuums, lawn equipment, and electronics, call or go on-line for the location of your nearest **Sears Parts and Repair Center.**

1-800-488-1222 Anytime, day or night (U.S.A. only)

www.sears.com

To purchase a protection agreement (U.S.A.) or maintenance agreement (Canada) on a product serviced by Sears:

1-800-827-6655 (U.S.A.)

1-800-361-6665 (Canada)

Para pedir servicio de reparación a domicilio, y para ordenar piezas:

1-888-SU-HOGARSM (1-888-784-6427)

SEARS

® Registered Trademark / ™ Trademark / ™ Service Mark of Sears, Roebuck and Co.
© Marca Registrada / ™ Marca de Fábrica / ™ Marca de Servicio de Sears, Roebuck and Co.

FULL 90 DAY WARRANTY

For 90 days from the date of purchase, if failure occurs due to defect in material or workmanship in this Sears Elliptical Exerciser, contact the nearest Sears Service Center throughout the United States and Sears will repair or replace the Elliptical Exerciser, free of charge.

This warranty does not apply when the Elliptical Exerciser is used commercially or for rental purposes.

This warranty gives you specific legal rights, and you may also have other rights which vary from state to state.

Sears, Roebuck and Co., Dept. 817WA, Hoffman Estates, IL 60179