

PRO-FORM®

710 E

www.proform.com

Model No. PFEL08011.0

Serial No. _____

Write the serial number in the space above for reference.

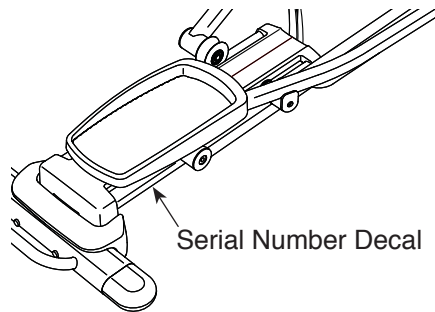

USER'S MANUAL

QUESTIONS?

If you have questions, or if parts are damaged or missing, **DO NOT CONTACT THE STORE**; please contact Customer Care.

IMPORTANT: Please register this product (see the limited warranty on the back cover of this manual) before contacting Customer Care.

CALL TOLL-FREE:

1-888-533-1333

Mon.–Fri. 6 a.m.–6 p.m. MT

Sat. 8 a.m.–4 p.m. MT

ON THE WEB:

www.proformservice.com

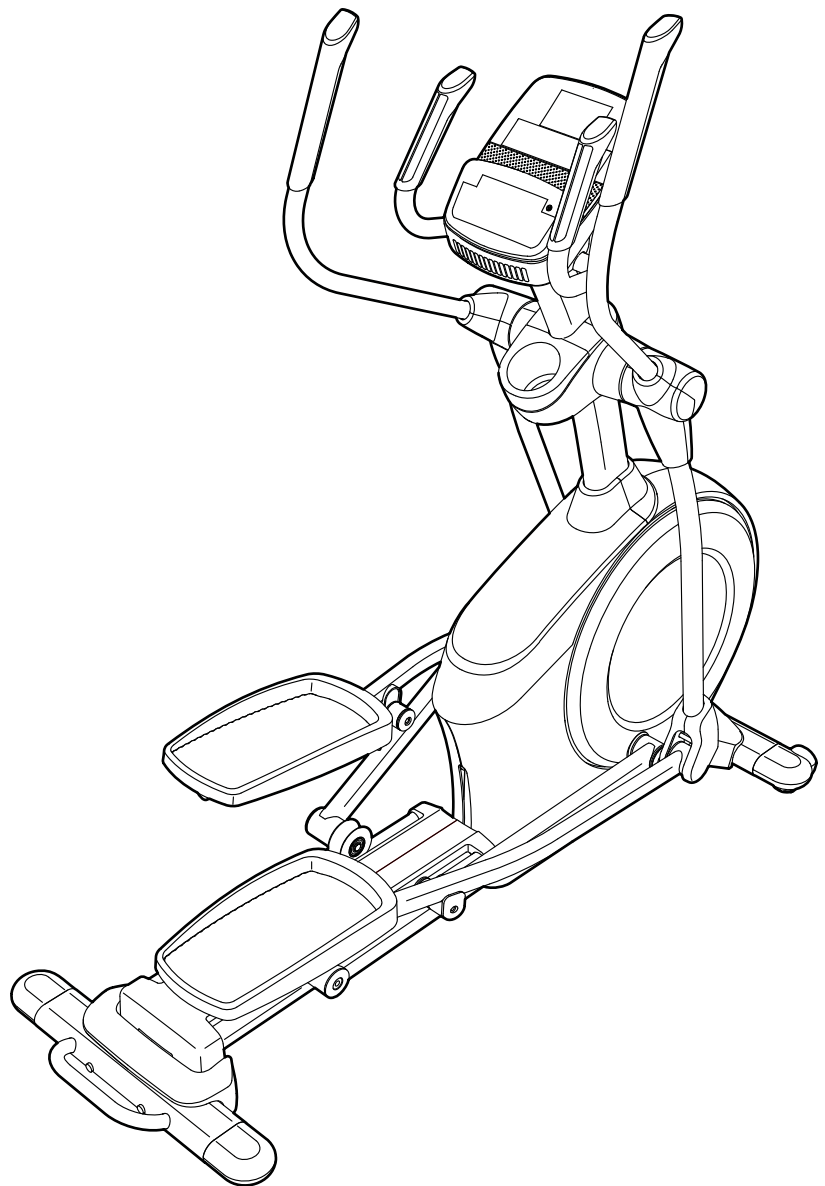

CAUTION

Read all precautions and instructions in this manual before using this equipment. Keep this manual for future reference.

FREE

  HOW-TO VIDEOS

www.iFit.com

TABLE OF CONTENTS

WARNING DECAL PLACEMENT	2
IMPORTANT PRECAUTIONS	3
BEFORE YOU BEGIN	4
PART IDENTIFICATION CHART	5
ASSEMBLY	6
HOW TO USE THE ELLIPTICAL	15
MAINTENANCE AND TROUBLESHOOTING	24
FCC INFORMATION	25
EXERCISE GUIDELINES	26
PART LIST	27
EXPLODED DRAWING	29
ORDERING REPLACEMENT PARTS	Back Cover
LIMITED WARRANTY	Back Cover

WARNING DECAL PLACEMENT

This drawing shows the location(s) of the warning decal(s). **If a decal is missing or illegible, see the front cover of this manual and request a free replacement decal. Apply the decal in the location shown.** Note: The decal(s) may not be shown at actual size.

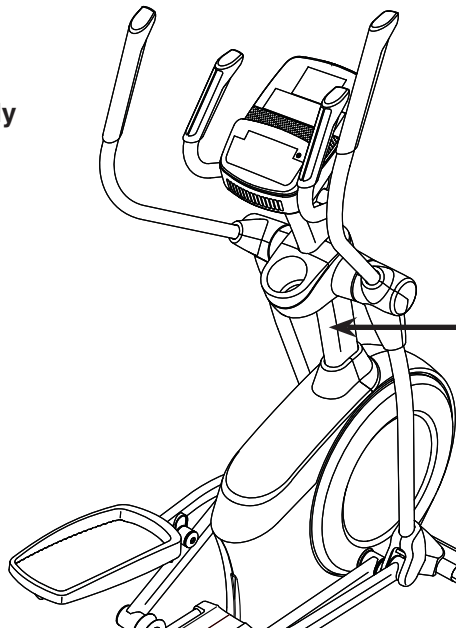

⚠ WARNING

- Misuse of this machine may result in serious injury.
- Read user's manual prior to use and follow all warnings and instructions.
- Do not allow children on or around machine.
- Pedals continue to spin when you stop pedaling.
- Spinning pedals can cause injury.
- Reduce pedal speed in a controlled manner.
- User weight must not exceed 300 pounds.
- Replace label if damaged, illegible, or removed.

IMPORTANT PRECAUTIONS

⚠️ WARNING: To reduce the risk of serious injury, read all important precautions and instructions in this manual and all warnings on your elliptical before using your elliptical. ICON assumes no responsibility for personal injury or property damage sustained by or through the use of this product.

1. Before beginning any exercise program, consult your physician. This is especially important for persons over age 35 or persons with pre-existing health problems.
2. Use the elliptical only as described in this manual.
3. It is the responsibility of the owner to ensure that all users of the elliptical are adequately informed of all precautions.
4. The elliptical is intended for home use only. Do not use the elliptical in a commercial, rental, or institutional setting.
5. Keep the elliptical indoors, away from moisture and dust. Do not put the elliptical in a garage or covered patio, or near water.
6. Place the elliptical on a level surface, with at least 3 ft. (0.9 m) of clearance in the front and rear of the elliptical and 2 ft. (0.6 m) on each side. To protect the floor or carpet from damage, place a mat under the elliptical.
7. Inspect and properly tighten all parts regularly. Replace any worn parts immediately.
8. Keep children under age 12 and pets away from the elliptical at all times.
9. The elliptical should not be used by persons weighing more than 300 lbs. (136 kg).
10. Wear appropriate clothes while exercising; do not wear loose clothes that could become caught on the elliptical. Always wear athletic shoes for foot protection while exercising.
11. Hold the handlebars or the upper body arms when mounting, dismounting, or using the elliptical.
12. The heart rate monitor is not a medical device. Various factors may affect the accuracy of heart rate readings. The heart rate monitor is intended only as an exercise aid in determining heart rate trends in general.
13. The elliptical does not have a freewheel; the pedals will continue to move until the flywheel stops. Reduce your pedaling speed in a controlled way.
14. Keep your back straight while using the elliptical; do not arch your back.
15. Over exercising may result in serious injury or death. If you feel faint or if you experience pain while exercising, stop immediately and cool down.

BEFORE YOU BEGIN

Thank you for selecting the revolutionary PROFORM® 710 E elliptical. The 710 E elliptical provides an impressive selection of features designed to make your workouts at home more effective and enjoyable.

For your benefit, read this manual carefully before you use the elliptical. If you have questions after reading this manual, please see the front cover of this

manual. To help us assist you, note the product model number and serial number before contacting us. The model number and the location of the serial number decal are shown on the front cover of this manual.

Before reading further, please familiarize yourself with the parts that are labeled in the drawing below.

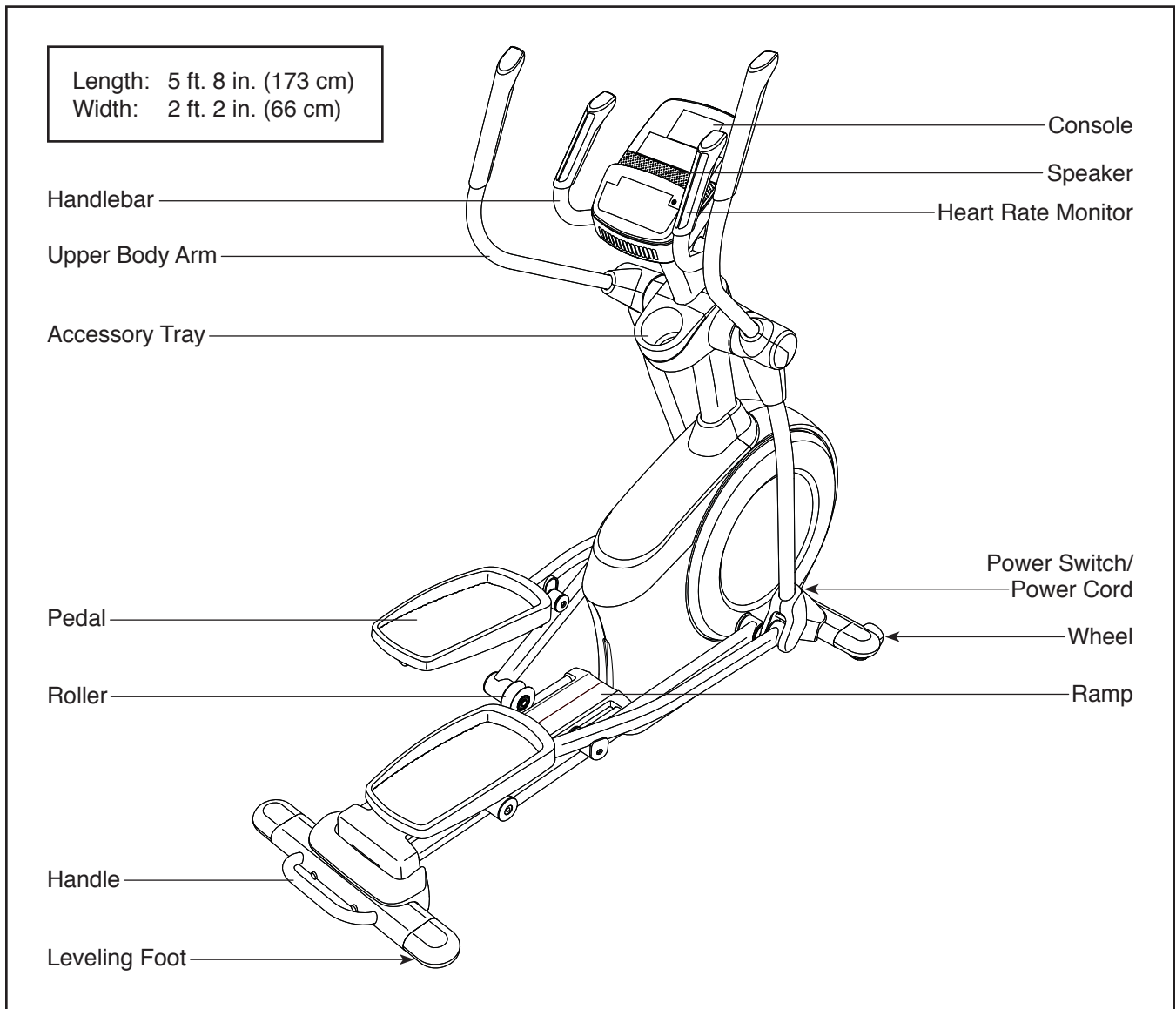

PART IDENTIFICATION CHART

Use the drawings below to identify the small parts needed for assembly. The number in parentheses below each drawing is the key number of the part, from the PART LIST near the end of this manual. The number following the key number is the quantity needed for assembly. **Note: If a part is not in the hardware kit, check to see if it has been preassembled. Extra parts may be included.**

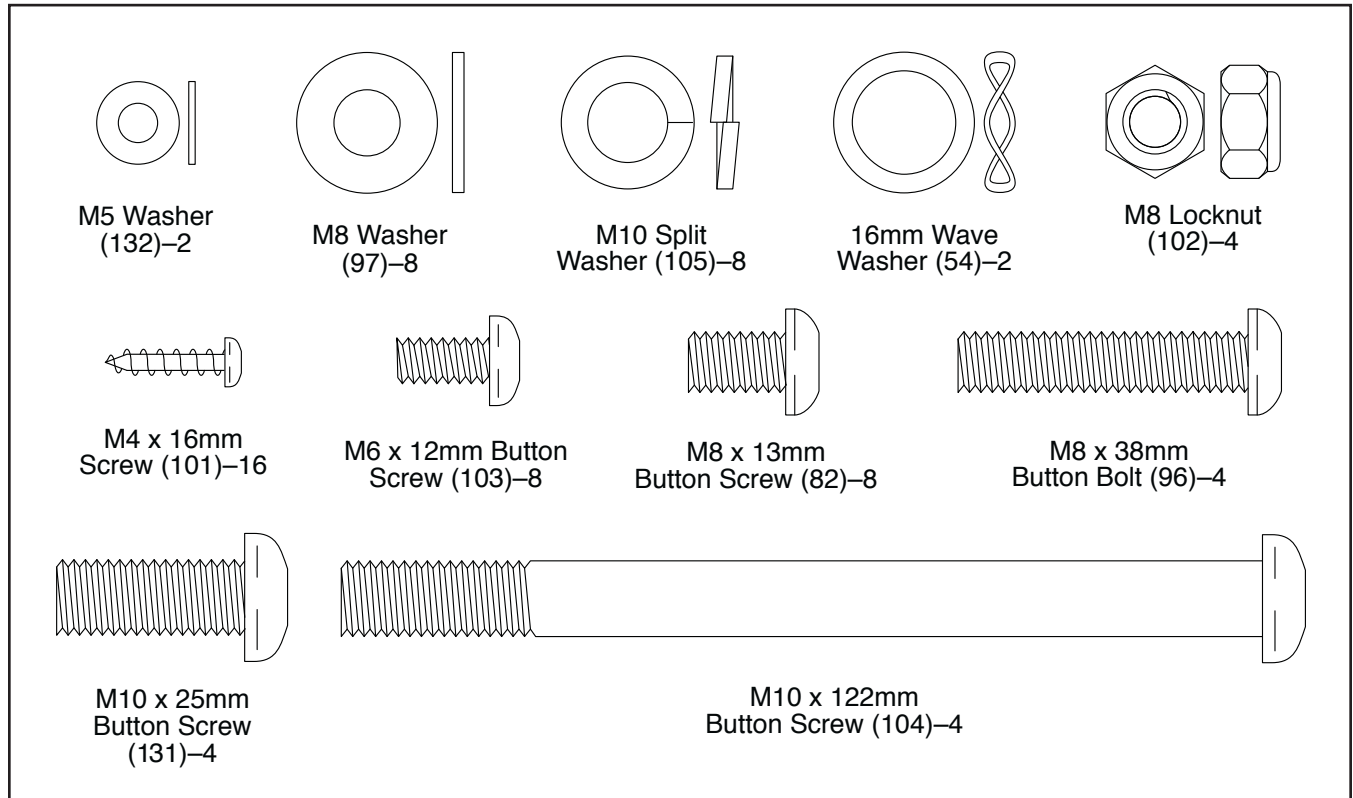

ASSEMBLY

- To hire an authorized service technician to assemble the elliptical, call 1-800-445-2480.
- Assembly requires two persons.
- Place all parts in a cleared area and remove the packing materials. Do not dispose of the packing materials until you complete all assembly steps.
- To identify small parts, see page 5.

- In addition to the included tool(s), assembly requires the following tools:

one Phillips screwdriver

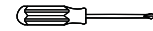

one rubber mallet



Assembly may be easier if you have your own set of wrenches. To avoid damaging parts, do not use power tools.

1. With the help of a second person, place some of the packing materials (not shown) under the rear of the Frame (1). **Have the second person hold the Frame to prevent it from tipping while you complete this step.**

Attach the Rear Stabilizer (2) to the Frame (1) with two M10 x 122mm Button Screws (104) and two M10 Split Washers (105).

Remove the packing materials from under the rear of the Frame (1).

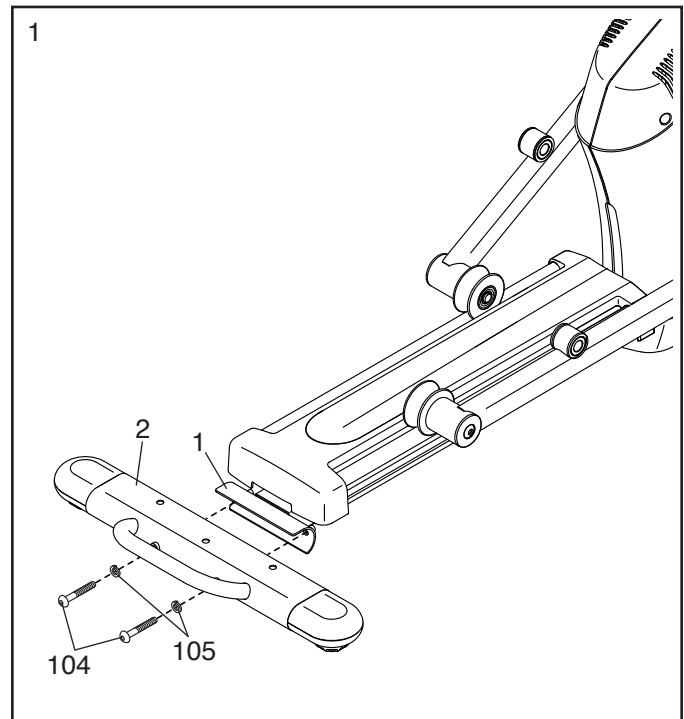

2. Press the Cover Mounts (106) on the underside of the Rear Stabilizer Cover (15) into the Rear Stabilizer (2).

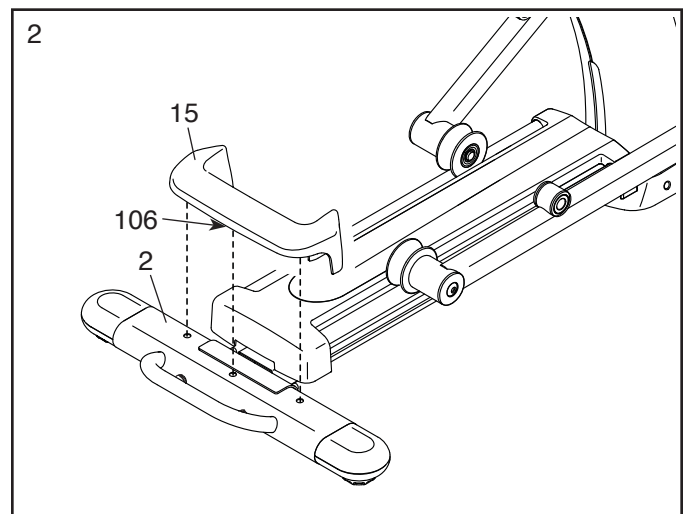

3. With the help of a second person, place some of the packing materials (not shown) under the front of the Frame (1). **Have the second person hold the Frame to prevent it from tipping while you complete this step.**

Attach the Front Stabilizer (6) to the Frame (1) with two M10 x 122mm Button Screws (104) and two M10 Split Washers (105).

Remove the packing materials from under the front of the Frame (1).

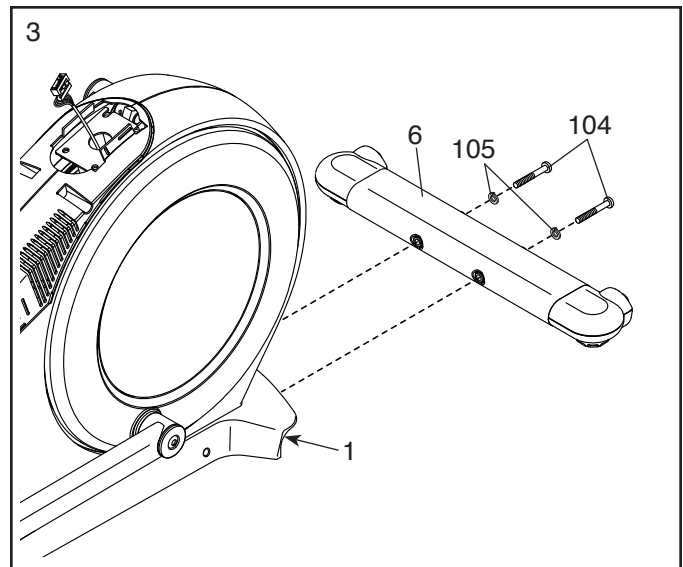

4. Orient the Upright (4) as shown. Have a second person hold the Upright near the Frame (1).

See the inset drawing. Locate the wire tie in the lower end of the Upright (4). Tie the wire tie to the Upper Wire (110). Then, pull the upper end of the wire tie until the Upper Wire is routed through the Upright.

Tip: To prevent the Upper Wire (110) from falling into the Upright (4), secure the Upper Wire with the wire tie.

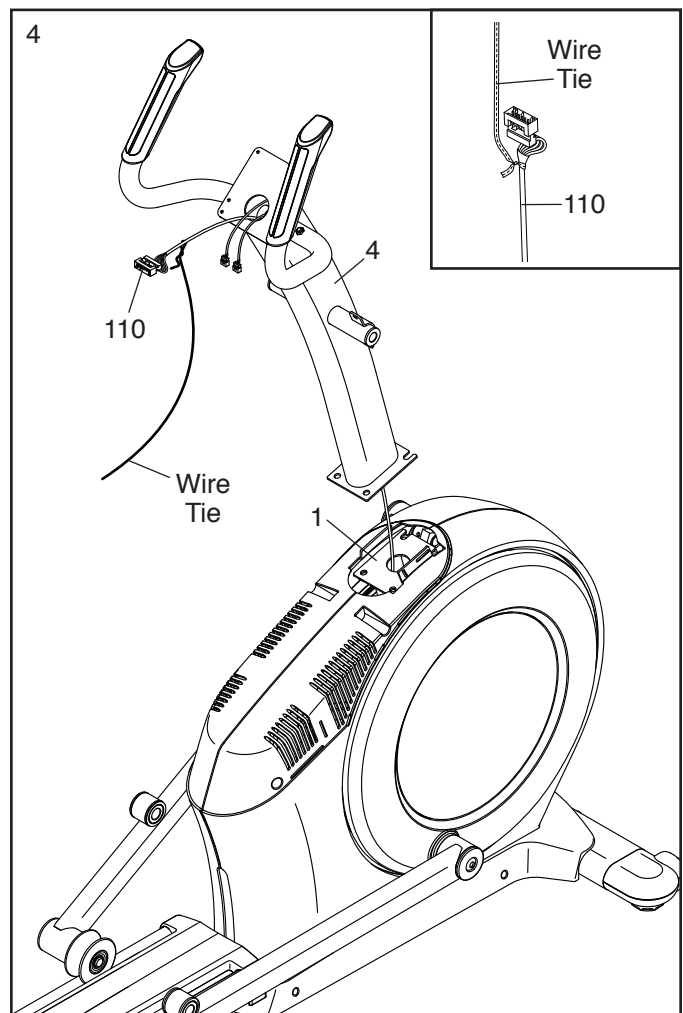

5. **Tip: Avoid pinching the Upper Wire (110).**
Avoid damaging the indicated plastic tabs.
Set the Upright (4) on the Frame (1).

Attach the Upright (4) with four M10 x 25mm Button Screws (131) and four M10 Split Washers (105).

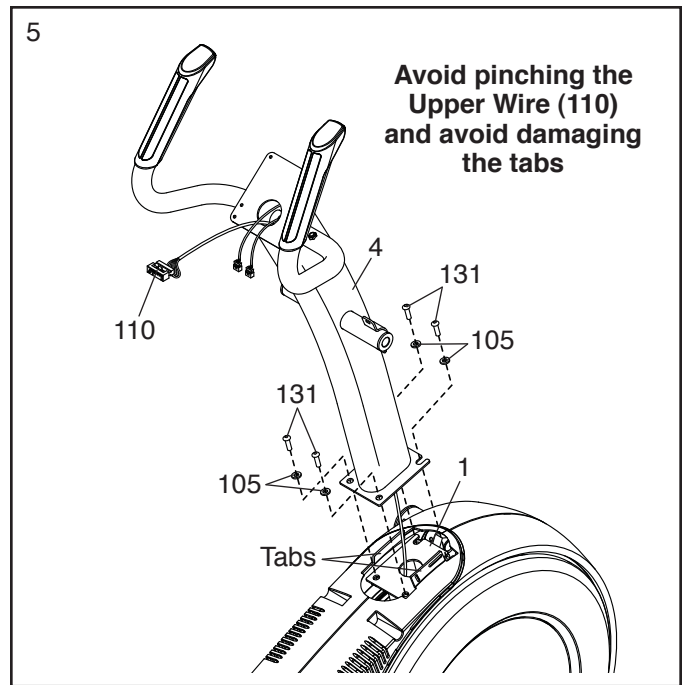

6. Using a plastic bag to keep your fingers clean, apply some of the included grease to the Pivot Axle (35) and to two 16mm Wave Washers (54).

Insert the Pivot Axle (35) through the Upright (4) and center it. **Tip: It may be helpful to use a rubber mallet.**

Identify the Right Upper Body Leg (60), which is marked with a "Right" sticker, and orient it as shown.

Slide a 16mm Wave Washer (54) and the Right Upper Body Leg (60) onto the right side of the Pivot Axle (35).

Repeat these actions for the Left Upper Body Leg (46).

Tighten an M8 x 13mm Button Screw (82) and an M8 Washer (97) into each end of the Pivot Axle (35) **at the same time.**

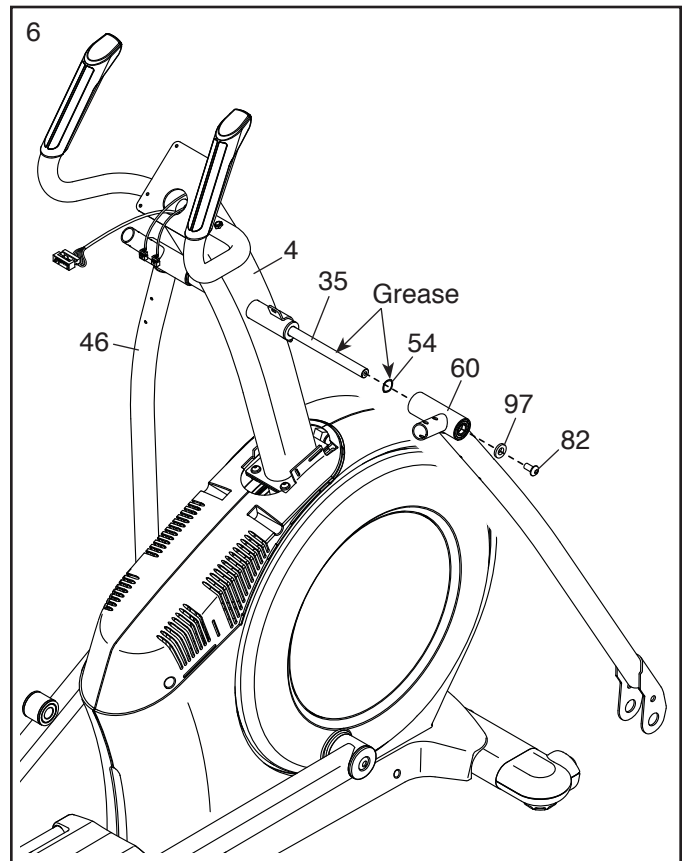

7. Identify the Right Upper Body Arm (61), which is marked with a “Right” sticker, and orient it as shown.

Slide the Right Upper Body Arm (61) onto the Right Upper Body Leg (60).

Attach the Right Upper Body Arm (61) with two M8 x 38mm Button Bolts (96) and two M8 Locknuts (102). **Make sure that the Locknuts are in the hexagonal holes.**

Repeat this step for the Left Upper Body Arm (47).

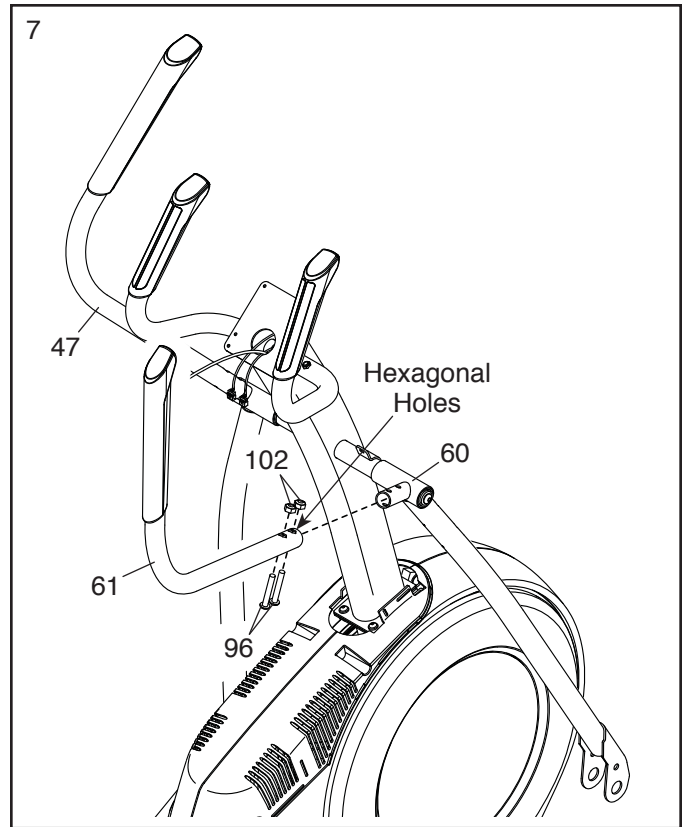

8. Untie and discard the wire tie on the Upper Wire (110).

While a second person holds the Console (7) near the Upright (4), connect the wires on the Console to the Upper Wire (110) and to the Sensor Wires (63).

Insert the excess wire into the Upright (4) or into the Console (7).

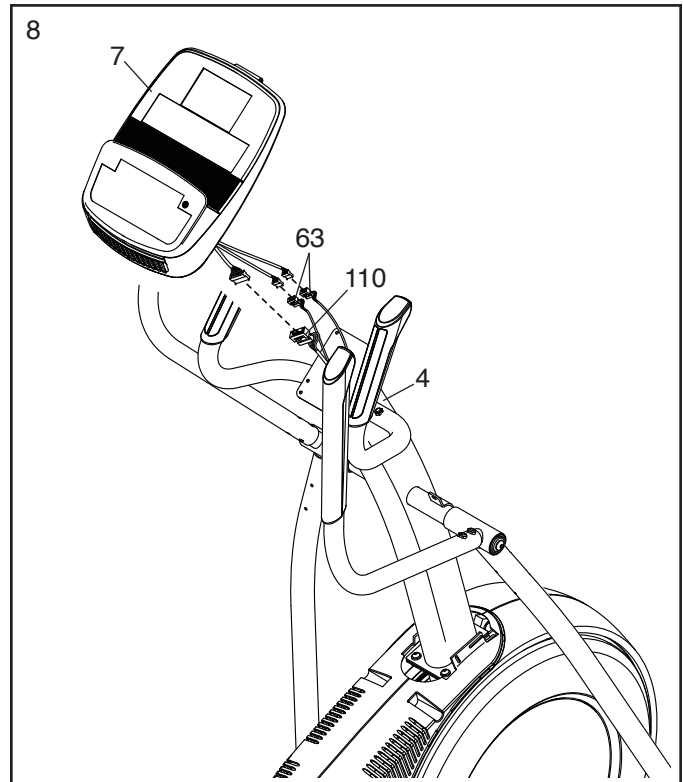

9. **Tip: Avoid pinching the wires.** Attach the Console (7) to the Upright (4) with four M4 x 16mm Screws (101).

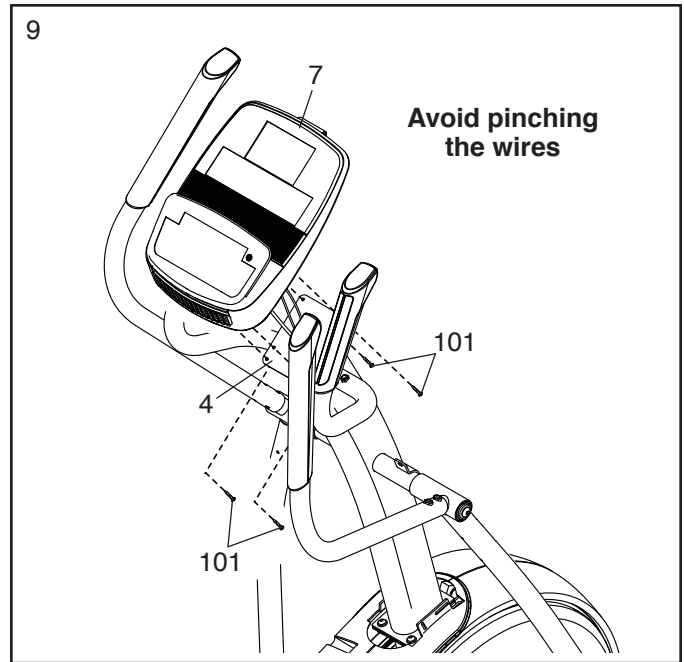

10. Identify the Right Pedal Arm (58), which is marked with a “Right” sticker, and orient it as shown.

Attach a Pedal (49) to the Right Pedal Arm (58) with four M6 x 12mm Button Screws (103).

Repeat this step for the Left Pedal Arm (44) and the other Pedal (49).

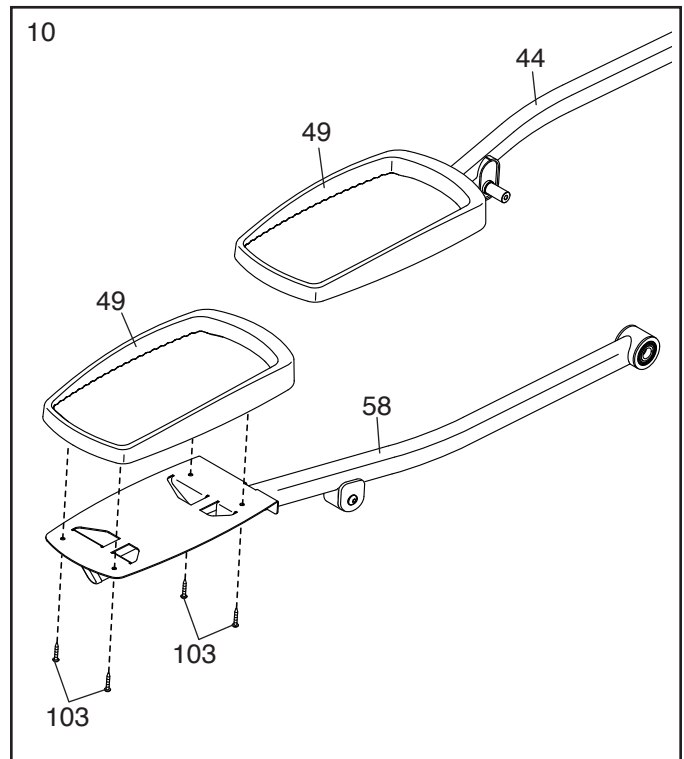

11. Orient the Right Pedal Arm (58) as shown.

Apply grease to the axle on the Right Pedal Arm (58).

Attach the Right Pedal Arm (58) to the Right Roller Arm (59) with an M8 x 13mm Button Screw (82), a Small Axle Cover (55), and an M8 Washer (97).

Repeat this step for the Left Pedal Arm (44).

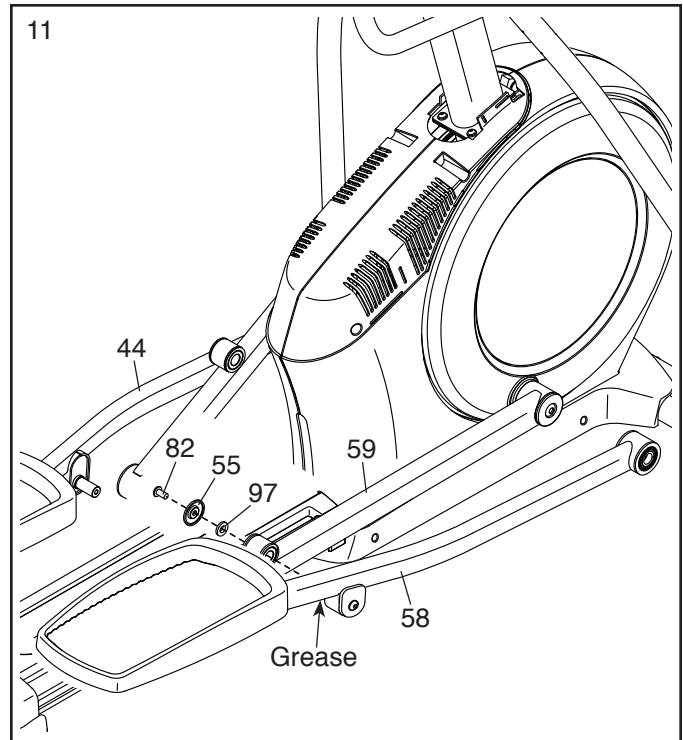

12. Apply a small amount of grease to one of the Pedal Arm Axles (64).

Next, slide an M8 Washer (97) and an Axle Spacer (77) onto an M8 x 13mm Button Screw (82), and tighten the Button Screw a few turns into the Pedal Arm Axle (64).

While a second person holds the front end of the Right Pedal Arm (58) inside the bracket on the Right Upper Body Leg (60), insert the Pedal Arm Axle (64) into both parts.

Slide an M8 Washer (97) and an Axle Spacer (77) onto another M8 x 13mm Button Screw (82), and tighten the Button Screw a few turns into the Pedal Arm Axle (64). **Then, tighten both Button Screws at the same time.**

Repeat this step on the other side of the elliptical.

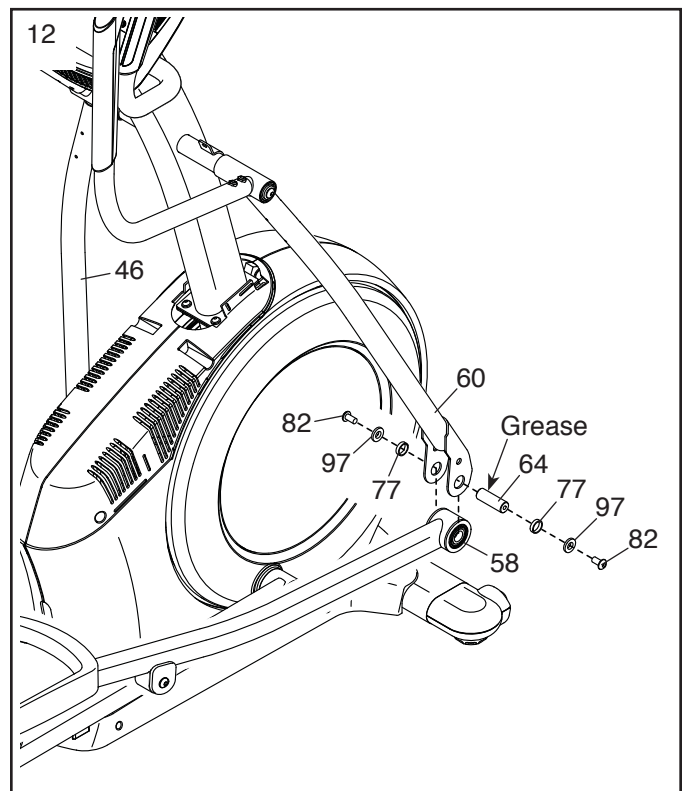

13. Orient the Rear Upright Cover (81) as shown.

Attach the Rear Upright Cover (81) to the Upright (4) with four M4 x 16mm Screws (101).

Orient the Front Upright Cover (117) as shown.

Attach the Front Upright Cover (117) around the Upright (4) by pressing the hooks on the Rear Upright Cover (81) onto the tabs on the Front Upright Cover.

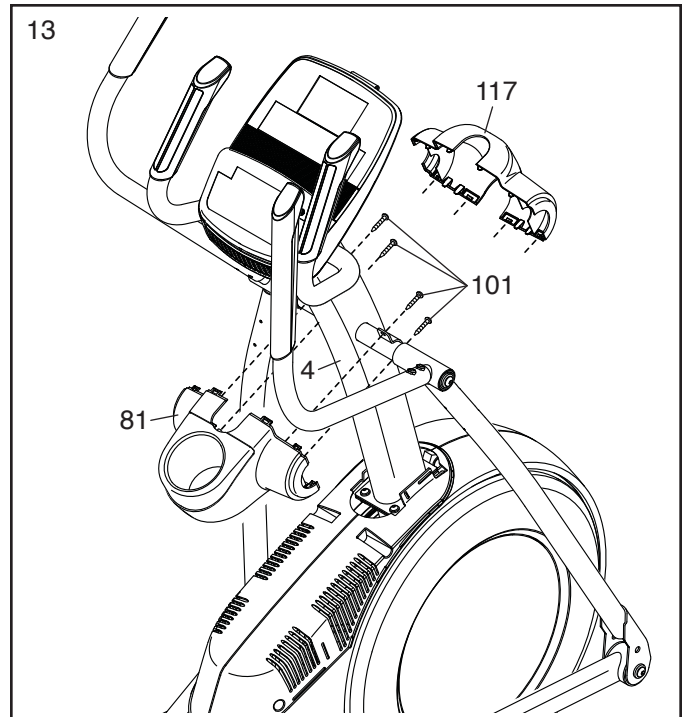

14. Identify the Right Upper Body Arm Front Cover (65), which is marked with a "Right" sticker, and orient it as shown.

Attach the Right Upper Body Arm Front Cover (65) to the Right Upper Body Leg (60) with two M4 x 16mm Screws (101).

Identify the Right Upper Body Arm Rear Cover (66), which is marked with a "Right" sticker and orient it as shown.

Attach the Right Upper Body Arm Rear Cover (66) around the Right Upper Body Leg (60) by pressing the hooks on the Right Upper Body Arm Rear Cover onto the tabs on the Right Upper Body Arm Front Cover (65).

Repeat this step on the other side of the elliptical.

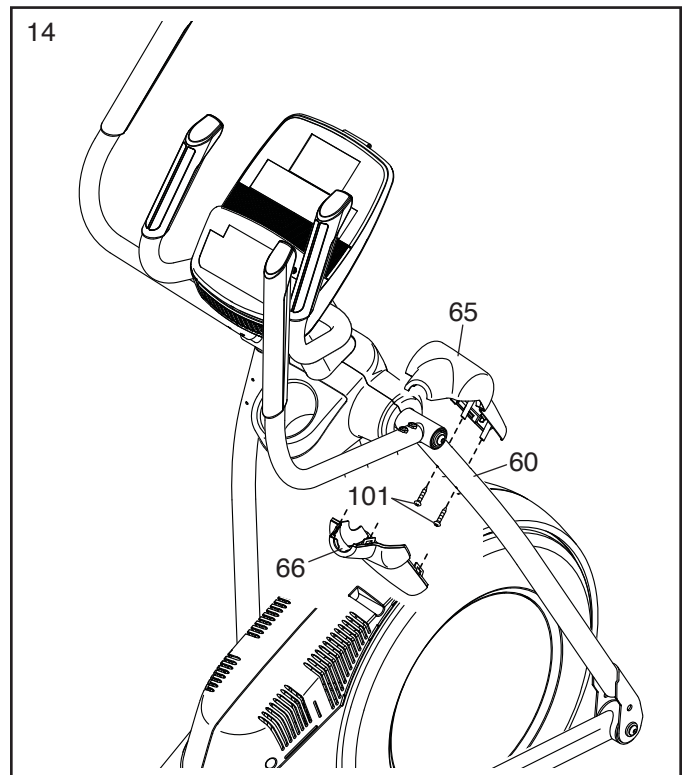

15. Identify the Right Upper Body Leg Inner Cover (83), which is marked with a “Right” sticker, and orient it as shown.

Attach the Right Upper Body Leg Inner Cover (83) to the Right Upper Body Leg (60) with an M4 x 16mm Screw (101) and an M5 Washer (132).

Identify the Right Upper Leg Outer Cover (69), which is marked with a “Right” sticker and orient it as shown.

Attach the Right Upper Leg Outer Cover (69) around the Right Upper Body Leg (60) by pressing the hooks on the Right Upper Body Leg Inner Cover (83) onto the tabs on the Right Upper Leg Outer Cover.

Repeat this step on the other side of the elliptical.

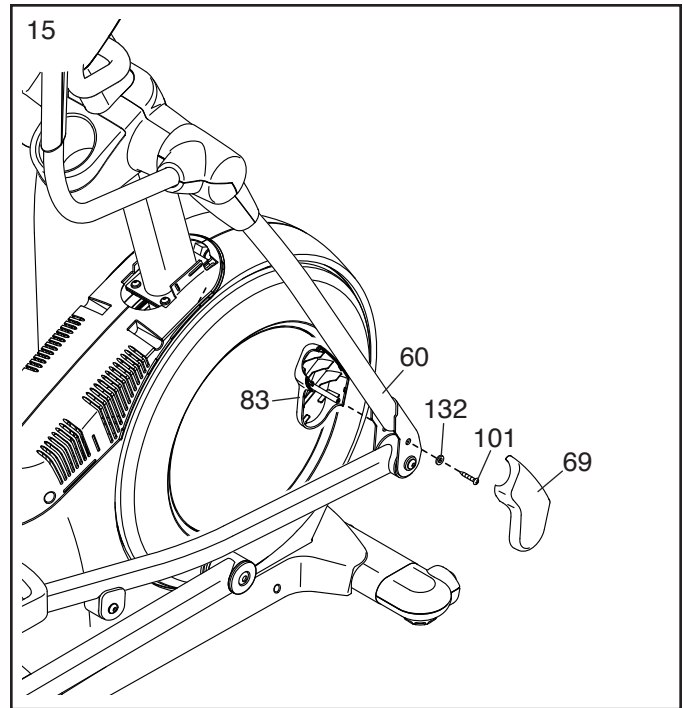

16. Orient the Shield Cover Cap (118) and the Shield Cover (75) as shown.

First, press the tabs on the Shield Cover Cap (118) into the Left and Right Shields (73, 74).

Then, press the tabs on the Shield Cover (75) into the Left and Right Shields (73, 74).

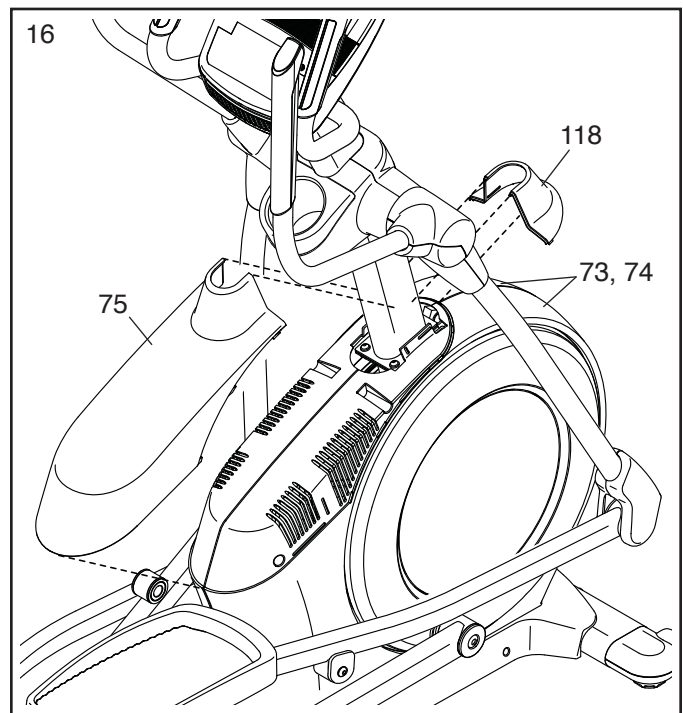

17. Orient the Rear Console Cover (80) as shown.

Attach the Rear Console Cover (80) to the Upright (4) with two M4 x 16mm Screws (101).

Orient the Front Console Cover (79) as shown.

Attach the Front Console Cover (79) around the Upright (4) by pressing the hooks on the Rear Console Cover (80) onto the tabs on the Front Console Cover.

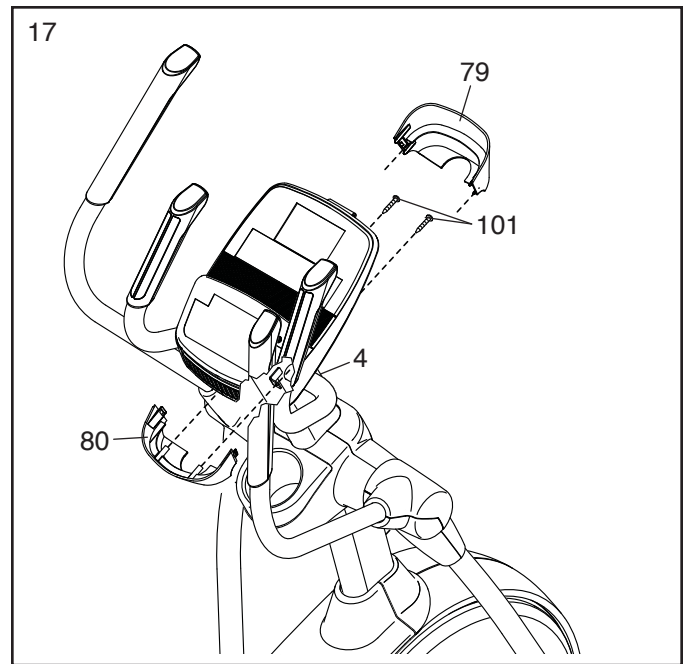

18. **Make sure that all parts are properly tightened before you use the elliptical.** Note: After assembly is completed, extra parts may be left over. Place a mat beneath the elliptical to protect the floor.

HOW TO USE THE ELLIPTICAL

HOW TO PLUG IN THE POWER CORD

This product must be grounded. If it should malfunction or break down, grounding provides a path of least resistance for electric current to reduce the risk of electric shock. The power cord has a plug with a grounding pin.

⚠ DANGER: Improper connection of the power cord increases the risk of electric shock. Do not modify the plug—if it will not fit an outlet, have a proper outlet installed by a qualified electrician. If you are unsure whether the product is properly grounded, contact a qualified electrician.

Plug the power cord into an appropriate outlet that is properly installed and grounded in accordance with all local codes and ordinances.

The outlet must be on a nominal 120-volt circuit. IMPORTANT: This product is not compatible with GFCI-equipped outlets and may not be compatible with AFCI-equipped outlets.

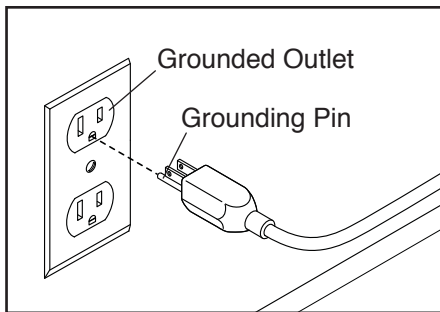

A temporary adapter may be used to connect the power cord to a 2-pole receptacle as shown at the right if a properly grounded outlet is not available.

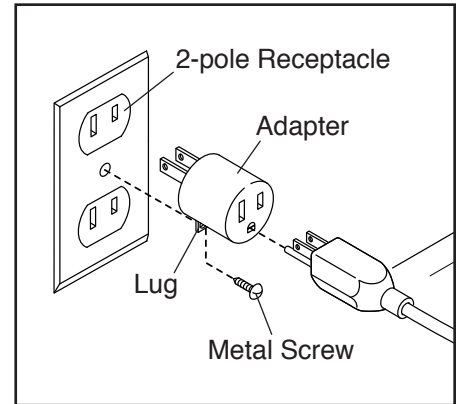

The lug or wire extending from the adapter must be connected with a metal screw to a permanent ground such as a properly grounded outlet box cover. **Some 2-pole receptacle outlet box covers are not grounded. Before using an adapter, contact a qualified electrician to determine whether the outlet box cover is grounded before using an adapter. The temporary adapter should be used only until a properly grounded outlet can be installed by a qualified electrician.**

HOW TO LEVEL THE ELLIPTICAL

If the elliptical rocks slightly on your floor during use, turn one or both of the leveling feet beneath the rear of the frame until the rocking motion is eliminated.

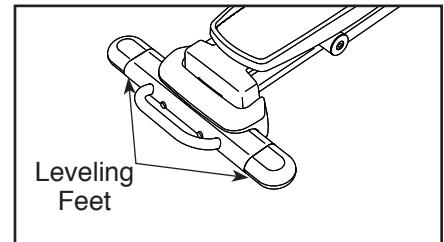

HOW TO MOVE THE ELLIPTICAL

Due to the size and weight of the elliptical, moving it requires two persons. Stand in front of the elliptical, hold the upright, and place one foot against one of the wheels. Pull on the upright and have a second person lift the handle until the elliptical will roll on the wheels. Carefully move the elliptical to the desired location, and then lower it to the floor.

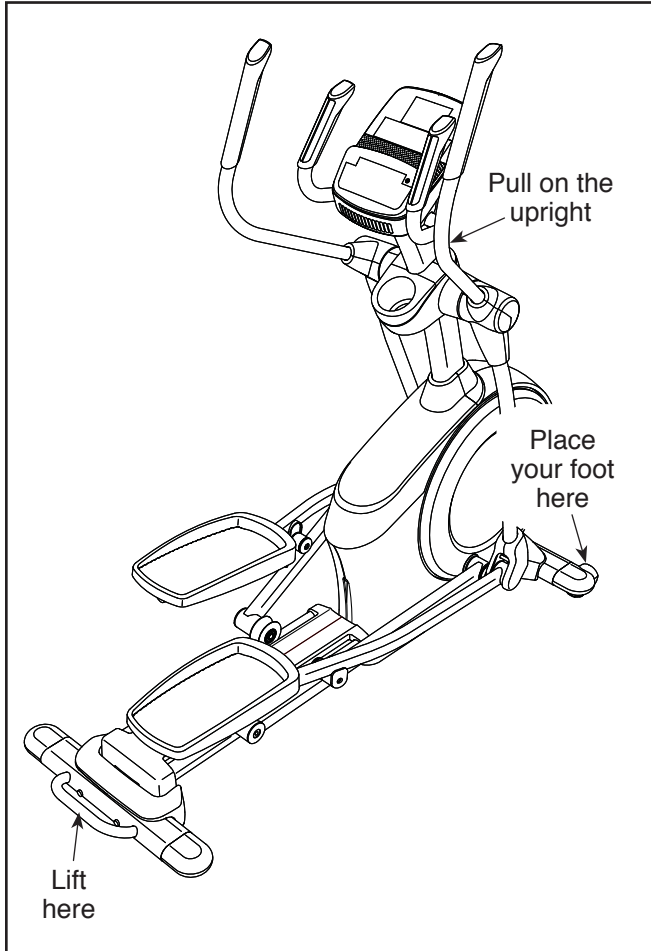

HOW TO EXERCISE ON THE ELLIPTICAL

To mount the elliptical, hold the handlebars or the upper body arms and step onto the pedal that is in the lower position. Then, step onto the other pedal. Push the pedals until they begin to move with a continuous motion. **Note: The pedals can turn in either direction. It is recommended that you turn the pedals in the direction shown by the arrow; however, for variety, you can turn the pedals in the opposite direction.**

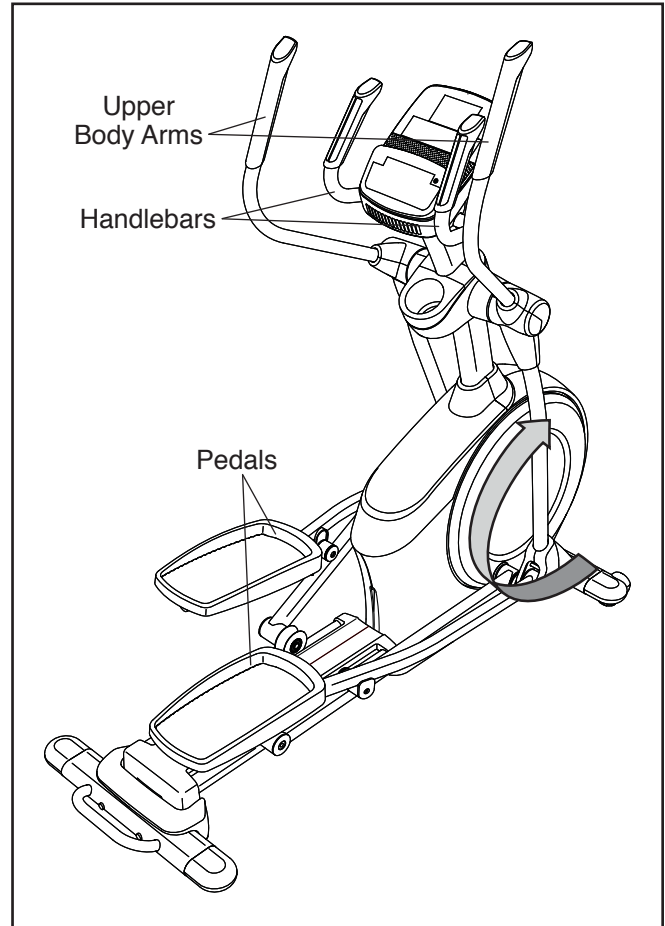

To dismount the elliptical, wait until the pedals come to a complete stop. **Note: The elliptical does not have a free wheel; the pedals will continue to move until the flywheel stops.** When the pedals are stationary, step off the higher pedal first. Then, step off the lower pedal.

CONSOLE DIAGRAM

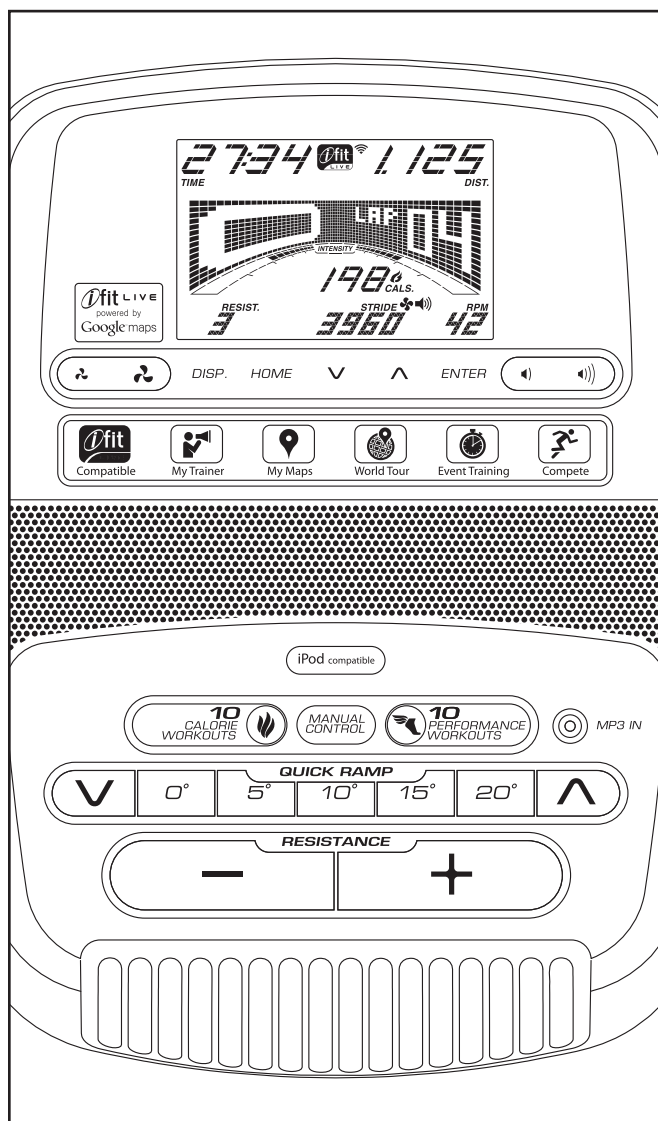

FEATURES OF THE CONSOLE

The advanced console offers an array of features designed to make your workouts more effective and enjoyable.

When you use the manual mode of the console, you can change the resistance of the pedals and the incline of the ramp with the touch of a button. While you exercise, the console will display continuous exercise feedback. You can also measure your heart rate using the handgrip heart rate monitor.

The console offers twenty onboard workouts—ten calorie workouts and ten performance workouts. Each workout automatically changes the resistance of the pedals as it guides you through an effective workout.

The console also features an iFit Live mode that enables the console to communicate with your wireless network through an optional iFit Live module. With the iFit Live mode, you can download personalized workouts, create your own workouts, track your workout results, race against other iFit Live users, and access many other features. **To purchase an iFit Live module at any time, go to www.iFit.com or call the telephone number on the front cover of this manual.**

You can even connect your MP3 player or CD player to the console sound system and listen to your favorite music or audio books while you exercise.

To turn on the power, see page 18. To use the manual mode, see page 18. To use an onboard workout, see page 20. To use an iFit Live workout, see page 21. To use the sound system, see page 22. To change console settings, see page 23.

Note: If there is a sheet of plastic on the display, remove the plastic.

HOW TO TURN ON THE POWER

IMPORTANT: If the elliptical has been exposed to cold temperatures, allow it to warm to room temperature before you turn on the power. If you do not do this, you may damage the console displays or other electrical components.

Plug in the power cord (see HOW TO PLUG IN THE POWER CORD on page 15). Next, locate the power switch on the frame near the power cord. Press the power switch to the reset position.

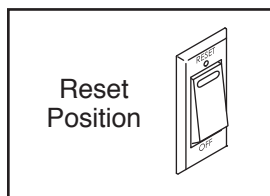

The display will then light and the console will be ready for use.

Note: When you turn on the power for the first time, the incline of the ramp will calibrate automatically. The ramp will move upward and downward as it calibrates. When the ramp stops moving, the ramp is calibrated.

IMPORTANT: If the incline of the ramp does not calibrate automatically, see HOW TO CALIBRATE THE RAMP on page 24 and manually calibrate the ramp.

HOW TO USE THE MANUAL MODE

1. **Begin pedaling or press any button on the console to turn on the console.**

See HOW TO TURN ON THE POWER above.

2. **Select the manual mode.**

Press the Manual Control button on the console to select the manual mode.

Note: If a wireless iFit Live module is not inserted into the console and connected to iFit Live, the manual mode will be selected automatically.

3. **Change the resistance of the pedals and the incline of the ramp as desired.**

As you pedal, change the resistance of the pedals by pressing the Resistance increase and decrease buttons.

Note: After you press a button, it will take a moment for the pedals to reach the selected resistance level.

To vary the motion of the pedals, you can change the incline of the ramp. To change the incline, press one of the numbered Quick Ramp buttons or press the Quick Ramp increase and decrease buttons.

Note: After you press a button, it will take a moment for the ramp to reach the selected incline level.

4. **Follow your progress with the display.**

The display can show the following workout information:

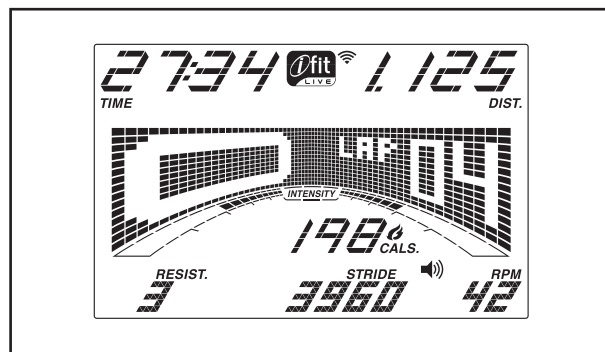

Calories (Cals.)—This display mode will show the approximate number of calories you have burned.

Calories per Hour (Cals./Hr)—This display mode will show the approximate number of calories you are burning per hour.

Distance (Dist.)—This display mode will show the distance that you have pedaled in miles or kilometers.

Incline—This display mode will show the incline level of the ramp for a few seconds each time the incline level changes.

Pulse—This display mode will show your heart rate when you use the handgrip heart rate monitor (see step 5 on page 19).

Resistance (Resist.)—This display mode will show the resistance level of the pedals for a few seconds each time the resistance level changes.

RPM—This display mode will show your pedaling speed in revolutions per minute (rpm).

Stride—This display mode will show the total number of strides you have pedaled.

Time—When the manual mode is selected, this display mode will show the elapsed time. When an onboard workout is selected, this display mode will show the time remaining in the workout.

The matrix offers several display tabs. Press the Disp button until the desired tab is shown. You can also press the increase and decrease buttons next to the Enter button.

Speed—This tab will show a profile of the speed settings of the workout. A new segment will appear at the end of each minute.

My Trail—This tab will show a track that represents 1/4 mile (400 m). As you exercise, the flashing rectangle will show your progress. The My Trail tab will also show the number of laps you complete.

Calorie—This tab will show the approximate amount of calories you have burned. The height of each segment represents the amount of calories burned during that segment.

As you exercise, the workout intensity level bar will indicate the approximate intensity level of your exercise.

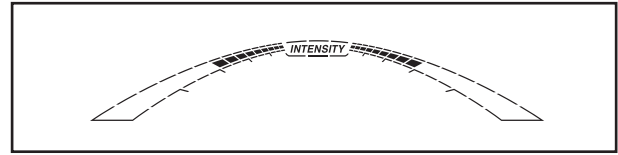

Press the Home button to return to the default menu (see HOW TO CHANGE CONSOLE SETTINGS on page 23 to set the default menu). If necessary, press the Home button again.

When a wireless iFit Live module is connected, the wireless symbol at the top of the display will show the strength of your wireless signal. Four arcs indicate full signal strength.



To exit the manual mode or a workout, press the Home button. If necessary, press the Home button again.

Change the volume level of the console by pressing the Volume increase and decrease buttons.



5. Measure your heart rate if desired.

If there are sheets of plastic on the metal contacts on the handgrip heart rate monitor, remove the plastic. To measure your heart rate, hold the handgrip heart rate monitor with your palms resting against the contacts. **Avoid moving your hands or gripping the contacts tightly.**

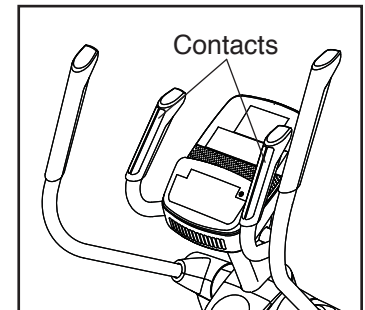

When your pulse is detected, a heart symbol in the calorie display will flash each time your heart beats, one or two dashes will appear, and then your heart rate will be shown. **For the most accurate heart rate reading, hold the contacts for at least 15 seconds.**

If the display does not show your heart rate, make sure that your hands are positioned as described. Be careful not to move your hands excessively or to squeeze the contacts tightly. For optimal performance, clean the contacts using a soft cloth; **never use alcohol, abrasives, or chemicals to clean the contacts.**

6. Turn on the fan if desired.

The fan has low and high speed settings. Press the Fan increase and decrease buttons repeatedly to select a fan speed or to turn off the fan.



Note: If the pedals do not move for about thirty seconds, the fan will turn off automatically.

7. When you are finished exercising, unplug the power cord.

If the pedals do not move for several seconds, a tone will sound and the console will pause.

If the pedals do not move for several minutes and the buttons are not pressed, the console will turn off and the display will be reset.

When you are finished exercising, press the power switch to the off position and unplug the power cord. **IMPORTANT: If you do not do this, the electrical components on the elliptical may wear prematurely.**

HOW TO USE AN ONBOARD WORKOUT

1. Begin pedaling or press any button on the console to turn on the console.

See HOW TO TURN ON THE POWER on page 18.

2. Select an onboard workout.

To select an onboard workout, press the 10 Calorie Workouts button or the 10 Performance Workouts button repeatedly until the desired workout appears in the display.

When you select an onboard workout, the display will show the duration of the workout and the name of the workout. A profile of the speed settings of the workout will appear in the matrix.

The display will also show the maximum speed (rpm), the maximum resistance level, and the maximum ramp level.

3. Begin pedaling to start the workout.

Each workout is divided into one-minute segments. One resistance level, one ramp incline level, and one target rpm (speed) are programmed for each segment. Note: The same resistance level, ramp incline level, and/or target rpm may be programmed for consecutive segments.

The resistance level, the ramp incline level, and the target rpm for the first segment will appear in the matrix.

During the workout, the profiles on the speed and incline tabs will show

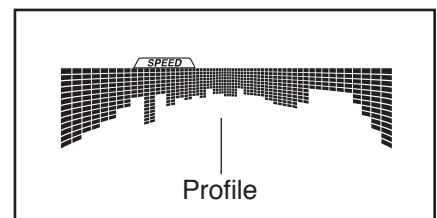

your progress. The flashing segment of the profile represents the current segment of the workout. The height of the flashing segment indicates the target speed or the incline level for the current segment.

At the end of each segment of the workout, a series of tones will sound and the next segment of the profile will begin to flash. If a different resistance level, ramp incline level, and/or target rpm is programmed for the next segment, the resistance level, ramp incline level, and/or target rpm will appear in the display for a few seconds to alert you. The resistance of the pedals and the incline level of the ramp will then change.

As you exercise, you will be prompted to keep your pedaling speed near the target rpm for the current segment. When an upward-pointing arrow appears in the display, increase your pace. When a downward-pointing arrow appears, decrease your pace. When no arrow appears, maintain your current pace.

IMPORTANT: The target rpm is intended only to provide motivation. Your actual pedaling speed may be slower than the target rpm. Make sure to pedal at a speed that is comfortable for you.

If the resistance level or incline level for the current segment is too high or too low, you can manually override the setting by pressing the Resistance buttons or the Quick Ramp buttons. **IMPORTANT: When the current segment of the workout ends, the pedals will automatically adjust to the resistance level programmed for the next segment and the ramp will automatically adjust to the incline level programmed for the next segment.**

The workout will continue in this way until the last segment ends. To stop the workout at any time, stop pedaling. The time will flash in the display. To resume the workout, simply resume pedaling.

4. Follow your progress with the display.

See step 4 on page 18.

5. Measure your heart rate if desired.

See step 5 on page 19.

6. Turn on the fan if desired.

See step 6 on page 20.

7. When you are finished exercising, unplug the power cord.

See step 7 on page 20.

HOW TO USE AN IFIT LIVE WORKOUT

You must have an iFit Live module to use an iFit Live workout.

To purchase an iFit Live module at any time, go to www.iFit.com or call the telephone number on the front cover of this manual.

Note: To use an iFit Live module, you must have access to a computer with an internet connection and a USB port. You will also need an iFit.com membership. To use a wireless iFit Live module, you must also have your own wireless network including an 802.11b router with SSID broadcast enabled (hidden networks are not supported).

IMPORTANT: To satisfy exposure compliance requirements, the antenna and transmitter in the iFit Live module must be at least 8 in. (20 cm) from all persons and must not be near or connected to any other antenna or transmitter.

1. Begin pedaling or press any button on the console to turn on the console.

See HOW TO TURN ON THE POWER on page 18.

2. Make sure that the iFit Live module is inserted in the console.

To use an iFit Live workout, make sure that the iFit Live module is inserted in the console.

3. Select the iFit Live mode.

To select the iFit Live mode, press the iFit Live button.

4. Select a user.

If more than one user is registered with your iFit.com membership, you can switch users in the iFit Live main screen. Press the increase and decrease buttons next to the Enter button to select a user.

5. Select an iFit Live workout.

To select an iFit Live workout, press one of the iFit Live buttons. Note: Before some workouts will download, you must go to www.iFit.com and add them to your schedule.

Press the iFit Live button to download the next workout in your schedule. Press the My Trainer button, the My Maps button, the World Tour button, or the Event Training button to download the next workout of that type in your schedule. Press the Compete button to compete in a race that you have previously scheduled. **For more information about the iFit Live workouts, please see www.iFit.com.**

When you select an iFit Live workout, the display will show the duration of the workout and the approximate number of calories you will burn. The display may also show the name of the workout. If you select a competition workout, the display may count down to the beginning of the race.

6. Start the workout.

See step 3 on page 20.

During some workouts, the voice of a personal trainer will guide you through your workout. You can select an audio setting for your personal trainer (see HOW TO CHANGE CONSOLE SETTINGS on page 23).

To stop the workout at any time, stop pedaling. The time will flash in the display. To resume the workout, simply resume pedaling.

7. Follow your progress with the display.

See step 4 on page 18.

The My Trail tab will show a map of the trail you are walking or running or it will show a track and the number of laps you complete.

During a competition workout, the Competition tab will show your progress in the race. As you race, the top line in the matrix will show how much of the race you have completed. The other lines will show other competitors. The end of the matrix represents the end of the race.

8. Measure your heart rate if desired.

See step 5 on page 19.

9. Turn on the fan if desired.

See step 6 on page 20.

10. When you are finished exercising, unplug the power cord.

See step 7 on page 20.

For more information about the iFit Live mode, go to www.iFit.com.

HOW TO USE THE SOUND SYSTEM

To play music or audio books through the console sound system while you exercise, plug the included audio cable into the jack on the console and into a jack on your MP3 player or CD player; **make sure that the audio cable is fully plugged in.**

Next, press the play button on your MP3 player or CD player. Adjust the volume level using the Volume increase and decrease buttons on the console or the volume control on your MP3 player or CD player.



HOW TO CHANGE CONSOLE SETTINGS

The console features a user mode that allows you to view usage information, select a unit of measurement, and adjust the contrast level of the display.

When an iFit Live module is connected to the console, you can also use the information mode to choose an audio setting for the voice of the personal trainer, set a default menu, check the status of the iFit Live module, and check for downloads.

1. Select the information mode.

To select the information mode, press and hold down the Disp button for a few seconds until the information mode appears in the display.

2. View usage information.

The display will show the total number of hours that the elliptical has been used. The display will also show the total distance (in miles or kilometers) that has been pedaled on the elliptical.

3. Select a unit of measurement if desired.

The word ENGLISH for English miles or the word METRIC for metric kilometers will appear in the display to indicate the currently selected unit of measurement.

To change the unit of measurement, press the Enter button repeatedly to select the desired unit of measurement.

4. Adjust the contrast level of the display if desired.

Press the decrease button to view the contrast level. The currently selected contrast level will appear in the display. Press the Resistance increase and decrease buttons to adjust the contrast level.

5. Determine if an iFit Live module is connected to the console.

If an iFit Live module is connected to the console, the display will show the words WIFI MODULE or USB MODULE.

If no module is connected, the display will show the words NO IFIT MODULE. If no module is connected, go to step 10.

6. Select an audio setting for the voice of the personal trainer if desired.

Press the decrease button to view the audio setting for the voice of the personal trainer. The currently selected audio setting for the voice of the personal trainer will appear in the display.

To change the audio setting, press the Enter button repeatedly to turn the voice of the personal trainer ON or OFF.

7. Set the default menu if desired.

Press the decrease button to view the default menu setting. The default menu is the menu that will appear when you turn on the console. Press the Enter button repeatedly to select the manual mode menu or the iFit Live menu as the default menu.

8. Check the status of the iFit Live module if desired.

Press the decrease button to view the iFit Live status display. The words CHECK WIFI STATUS or CHECK USB STATUS will appear in the display.

Then, press the Enter button. After a few seconds, the status of the iFit Live module will appear in the display. To exit this display, press and hold down the Disp button for a few seconds.

9. Check for downloads if desired.

Press the decrease button to view the downloads display. The words SEND/RECEIVE DATA will appear in the display.

Then, press the Enter button. The console will then check for iFit Live workouts and firmware downloads.

10. Exit the information mode.

Press the Disp button to exit the information mode.

MAINTENANCE AND TROUBLESHOOTING

Inspect and tighten all parts of the elliptical regularly. Replace any worn parts immediately.

To clean the elliptical, use a damp cloth and a small amount of mild soap. **IMPORTANT: To avoid damage to the console, keep liquids away from the console and keep the console out of direct sunlight.**

CONSOLE TROUBLESHOOTING

If the console does not turn on, make sure that the power cord is fully plugged in. If lines appear in the console display, see **HOW TO CHANGE CONSOLE SETTINGS** on page 23 and adjust the contrast level of the display.

If the console does not display your heart rate when you hold the handgrip heart rate monitor, or if the displayed heart rate appears to be too high or too low, see step 5 on page 19.

HOW TO LEVEL THE ELLIPTICAL

If the elliptical rocks slightly on your floor during use, see **HOW TO LEVEL THE ELLIPTICAL** on page 15.

HOW TO CALIBRATE THE RAMP

If the ramp is not functioning properly, the ramp may need to be calibrated. To calibrate the ramp, press and hold the 10 Calorie Workouts button for several seconds until the test mode appears in the display.

Press the 10 Calorie Workouts button again. Then, press the Quick Ramp increase or decrease button to calibrate the ramp. The ramp will move upward and downward as it calibrates.

When the ramp stops moving, the ramp is calibrated. Then, press the 10 Calorie Workouts button repeatedly to exit the calibration mode.

HOW TO GREASE THE ROLLERS

See the **EXPLODED DRAWING** near the end of this manual. If the Rollers (51) squeak when moving on the Tracks (16), apply a small amount of white marine grease equally to each Roller. Spread the grease evenly around the Rollers. Pedal the elliptical until a thin film of grease is distributed along the Tracks; then, wipe off any excess grease.

HOW TO ADJUST THE REED SWITCH

If the console does not display correct feedback, the reed switch should be adjusted.

See **EXPLODED DRAWING C** on page 31. Using a flat screwdriver, remove the left Disc (71).

Note: For clarity, the left shield and the left disc ring are shown removed in the drawing below.

Next, locate the Reed Switch (38). Turn the Pulley (19) until a Magnet (43) is aligned with the Reed Switch.

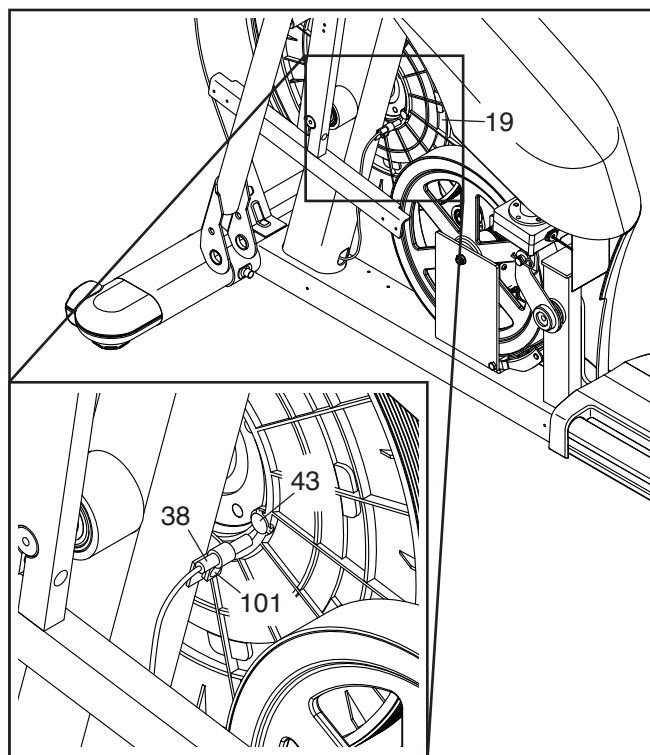

Loosen, but do not remove, the indicated M4 x 16mm Screw (101). Slide the Reed Switch (38) slightly closer to or away from the Magnet (43), and then retighten the Screw. Then, rock the Pulley (19) forward and backward just enough that the Magnet passes the Reed Switch repeatedly.

Repeat these actions until the console displays correct feedback. When the reed switch is correctly adjusted, reattach the left disc.

HOW TO ADJUST THE DRIVE BELT

If the pedals slip while you are pedaling, even while the resistance is adjusted to the highest level, the drive belt may need to be adjusted.

To adjust the drive belt, first see assembly step 16 on page 13. Use a flat screwdriver to remove the Shield Cover (75) and the Shield Cover Cap (118).

Next, see assembly step 15 on page 13 and remove the Right Upper Body Leg Outer and Inner Covers (69, 83).

Then, see assembly step 12 on page 11 and remove the Right Pedal Arm (58) from the Right Upper Body Leg (60).

See EXPLODED DRAWING C on page 31 and EXPLODED DRAWING A on page 29. Remove the Right Roller Arm (59) from the right Crank Arm (20). Then, carefully remove the Right Roller Arm assembly from the elliptical.

See EXPLODED DRAWING C on page 31. Remove the M4 x 19mm Screws (5) and the M4 x 48mm Screw (107) from the Left and Right Shields (73, 74). Then, remove the Right Shield.

Next, locate and loosen the Idler Screw (89). Next, tighten the Belt Adjustment Screw (91) until the Drive Belt (113) is tight. Then, retighten the Idler Screw.

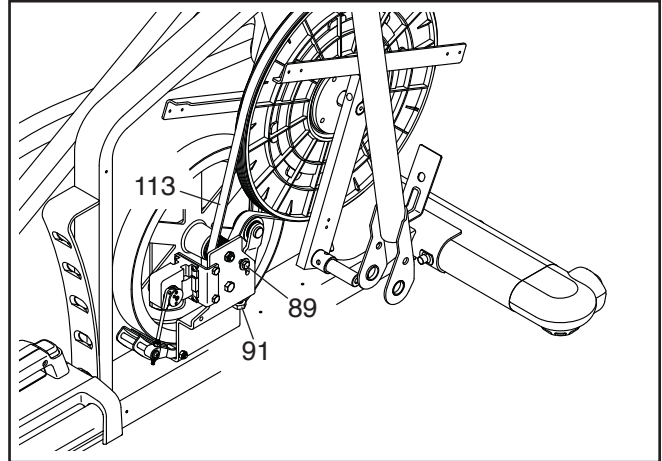

Reattach the right shield, the right roller arm, the right pedal arm, the shield cover cap, and the shield cover.

FCC INFORMATION

This equipment has been tested and found to comply with the limits for a Class B digital device, pursuant to part 15 of the FCC Rules. These limits are designed to provide reasonable protection against harmful interference in a residential installation. This equipment generates, uses, and can radiate radio frequency energy and, if not installed and used in accordance with the instructions, may cause harmful interference to radio communications. However, there is no guarantee that interference will not occur in a particular installation. If this equipment does cause harmful interference to radio or television reception, which can be determined by turning the equipment off and on, try to correct the interference by one or more of the following measures:

- Reorient or relocate the receiving antenna.
- Increase the separation between the equipment and the receiver.
- Connect the equipment into an outlet on a circuit different from that to which the receiver is connected.
- Consult the dealer or an experienced radio/TV technician for help.

FCC CAUTION: To assure continued compliance, use only shielded interface cables when connecting to computer or peripheral devices. Changes or modifications not expressly approved by the party responsible for compliance could void the user's authority to operate this equipment.

EXERCISE GUIDELINES

⚠️ WARNING: Before beginning this or any exercise program, consult your physician. This is especially important for persons over age 35 or persons with pre-existing health problems.

The heart rate monitor is not a medical device. Various factors may affect the accuracy of heart rate readings. The heart rate monitor is intended only as an exercise aid in determining heart rate trends in general.

These guidelines will help you to plan your exercise program. For detailed exercise information, obtain a reputable book or consult your physician. Remember, proper nutrition and adequate rest are essential for successful results.

EXERCISE INTENSITY

Whether your goal is to burn fat or to strengthen your cardiovascular system, exercising at the proper intensity is the key to achieving results. You can use your heart rate as a guide to find the proper intensity level. The chart below shows recommended heart rates for fat burning and aerobic exercise.

165	155	145	140	130	125	115	♥♥
145	138	130	125	118	110	103	♥
125	120	115	110	105	95	90	♥
<hr/>							
20	30	40	50	60	70	80	

To find the proper intensity level, find your age at the bottom of the chart (ages are rounded off to the nearest ten years). The three numbers listed above your age define your “training zone.” The lowest number is the heart rate for fat burning, the middle number is the heart rate for maximum fat burning, and the highest number is the heart rate for aerobic exercise.

Burning Fat—To burn fat effectively, you must exercise at a low intensity level for a sustained period of time. During the first few minutes of exercise, your body uses carbohydrate calories for energy. Only after the first few minutes of exercise does your body begin to use stored fat calories for energy. If your goal is to burn fat, adjust the intensity of your exercise until your heart rate is near the lowest number in your training zone. For maximum fat burning, exercise with your heart rate near the middle number in your training zone.

Aerobic Exercise—If your goal is to strengthen your cardiovascular system, you must perform aerobic exercise, which is activity that requires large amounts of oxygen for prolonged periods of time. For aerobic exercise, adjust the intensity of your exercise until your heart rate is near the highest number in your training zone.

WORKOUT GUIDELINES

Warming Up—Start with 5 to 10 minutes of stretching and light exercise. A warm-up increases your body temperature, heart rate, and circulation in preparation for exercise.

Training Zone Exercise—Exercise for 20 to 30 minutes with your heart rate in your training zone. (During the first few weeks of your exercise program, do not keep your heart rate in your training zone for longer than 20 minutes.) Breathe regularly and deeply as you exercise—never hold your breath.

Cooling Down—Finish with 5 to 10 minutes of stretching. Stretching increases the flexibility of your muscles and helps to prevent post-exercise problems.

EXERCISE FREQUENCY

To maintain or improve your condition, complete three workouts each week, with at least one day of rest between workouts. After a few months of regular exercise, you may complete up to five workouts each week, if desired. Remember, the key to success is to make exercise a regular and enjoyable part of your everyday life.

PART LIST

Model No. PFEL08011.0 R1111A

Key No.	Qty.	Description	Key No.	Qty.	Description
1	1	Frame	51	2	Roller
2	1	Rear Stabilizer	52	2	Pedal Arm Rear Cap
3	1	Ramp	53	4	Large Axle Cover
4	1	Upright	54	2	16mm Wave Washer
5	8	M4 x 19mm Screw	55	2	Small Axle Cover
6	1	Front Stabilizer	56	4	Roller Arm Bushing
7	1	Console	57	8	Arm Bearing
8	1	Left Handlebar	58	1	Right Pedal Arm
9	1	Right Handlebar	59	1	Right Roller Arm
10	1	Ramp Cover	60	1	Right Upper Body Leg
11	1	Incline Motor	61	1	Right Upper Body Arm
12	1	Incline Motor Arm	62	2	Grip
13	1	Ramp Arm	63	2	Sensor Assembly/Wire
14	1	Ramp Roller	64	2	Pedal Arm Axle
15	1	Rear Stabilizer Cover	65	1	Right Upper Body Arm Front Cover
16	2	Track	66	1	Right Upper Body Arm Rear Cover
17	2	Large Frame Bushing	67	1	Left Upper Body Arm Front Cover
18	1	Crank	68	1	Left Upper Body Arm Rear Cover
19	1	Pulley	69	1	Right Upper Body Leg Outer Cover
20	2	Crank Arm	70	1	Left Upper Body Leg Outer Cover
21	4	M4 x 10mm Screw	71	2	Disc
22	1	Idler	72	1	Left Upper Body Leg Inner Cover
23	1	C-magnet	73	1	Left Shield
24	1	Motor Bracket	74	1	Right Shield
25	1	Resistance Motor	75	1	Shield Cover
26	1	Resistance Rod	76	1	Left Pedal Arm Side Cap
27	1	Resistance Disc	77	4	Axle Spacer
28	1	Flywheel	78	2	Key
29	1	Flywheel Axle	79	1	Front Console Cover
30	2	Rear Upper Cap	80	1	Rear Console Cover
31	2	Rear Lower Cap	81	1	Rear Upright Cover
32	1	Front Right Upper Cap	82	12	M8 x 13mm Button Screw
33	2	Leveling Foot	83	1	Right Upper Body Leg Inner Cover
34	2	Wheel	84	1	Front Left Lower Cap
35	1	Pivot Axle	85	2	M4 x 14mm Button Screw
36	2	Upright Bushing	86	2	M10 x 58mm Button Bolt
37	1	Accessory Tray	87	1	Right Pedal Arm Side Cap
38	1	Reed Switch/Wire	88	1	Pivot Screw
39	1	Reed Switch Clamp	89	1	Idler Screw
40	2	Frame Bearing	90	3	M6 Washer
41	2	Flywheel Bearing	91	1	Belt Adjustment Screw
42	1	Large Snap Ring	92	1	M6 x 65mm Bolt
43	2	Magnet	93	4	M4 x 12mm Screw
44	1	Left Pedal Arm	94	1	M6 Locknut
45	1	Left Roller Arm	95	6	M8 x 16mm Button Screw
46	1	Left Upper Body Leg	96	8	M8 x 38mm Button Bolt
47	1	Left Upper Body Arm	97	10	M8 Washer
48	1	Hairpin Cotter Pin	98	2	Medium Snap Ring
49	2	Pedal	99	1	Small Snap Ring
50	1	Front Right Lower Cap	100	4	Leg Bearing

Key No.	Qty.	Description	Key No.	Qty.	Description
101	39	M4 x 16mm Screw	124	1	Controller Bracket
102	12	M8 Locknut	125	2	Motor Bracket Screw
103	8	M6 x 12mm Button Screw	126	1	M3.5 x 12mm Flat Head Screw
104	4	M10 x 122mm Button Screw	127	2	Adjustment Nut
105	8	M10 Split Washer	128	1	M5 x 7mm Screw
106	3	Cover Mount	129	1	Resistance Bracket
107	1	M4 x 48mm Screw	130	1	M5 Washer
108	2	M6 x 13mm Screw	131	4	M10 x 25mm Button Screw
109	2	M8 x 45mm Button Bolt	132	2	M5 Washer
110	1	Upper Wire	133	2	M10 x 19mm Button Screw
111	1	Lower Wire Harness	134	3	M10 Washer
112	1	Audio Cable	135	4	M10 Locknut
113	1	Drive Belt	136	1	Power Switch
114	4	M4 x 42mm Screw	137	1	Controller
115	1	Front Left Upper Cap	138	4	Standoff
116	2	Disc Ring	139	1	M10 x 42mm Bolt
117	1	Front Upright Cover	140	1	M10 x 95mm Bolt
118	1	Shield Cover Cap	141	1	M10 x 15mm Screw
119	1	Power Cord	142	1	Control Board
120	1	Ramp Axle	*	–	Assembly Tool
121	6	Small Frame Bushing	*	–	Grease Packet
122	1	Clevis Pin	*	–	User's Manual
123	1	Plastic Spacer			

Note: Specifications are subject to change without notice. For information about ordering replacement parts, see the back cover of this manual. *These parts are not illustrated.

EXPLODED DRAWING A

Model No. PFEL08011.0 R1111A

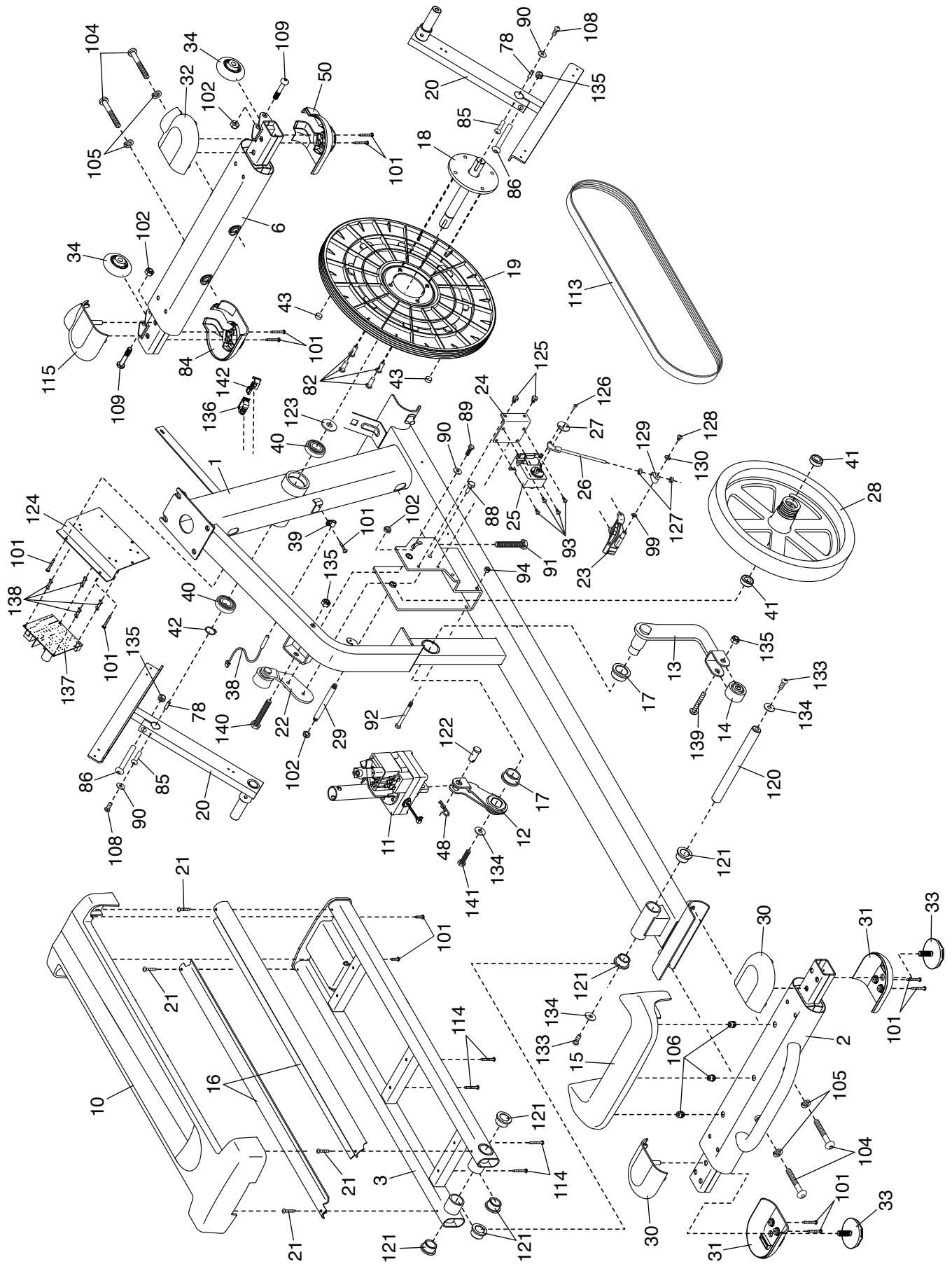

EXPLODED DRAWING B

Model No. PFEL08011.0 R1111A

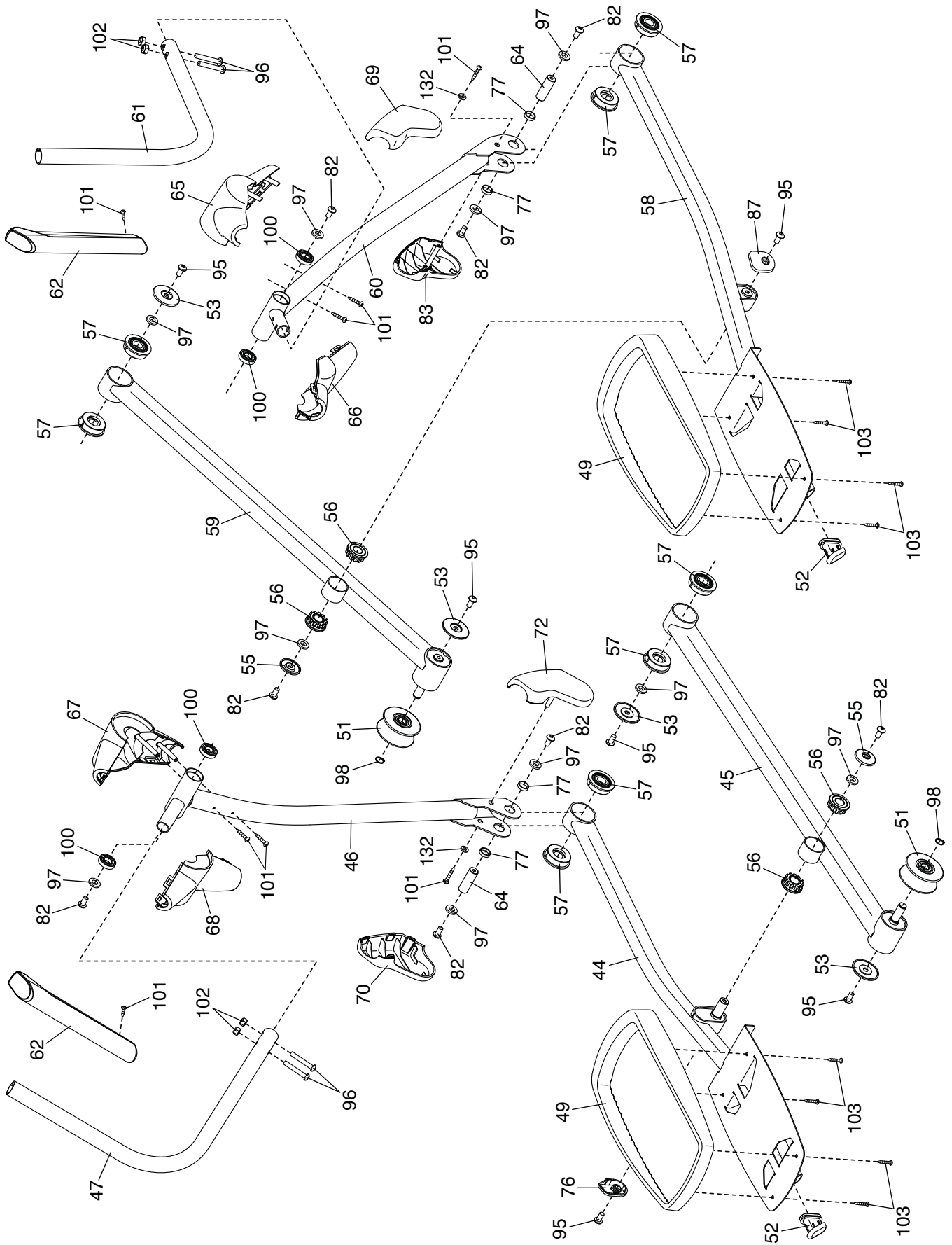

ORDERING REPLACEMENT PARTS

To order replacement parts, please see the front cover of this manual. To help us assist you, be prepared to provide the following information when contacting us:

- the model number and serial number of the product (see the front cover of this manual)
- the name of the product (see the front cover of this manual)
- the key number and description of the replacement part(s) (see the PART LIST and the EXPLODED DRAWING near the end of this manual)

LIMITED WARRANTY

IMPORTANT: You must register this product within 30 days of the purchase date to avoid added fees for service needed under warranty. Go to www.proformservice.com/registration.

ICON Health & Fitness, Inc. (ICON) warrants this product to be free from defects in workmanship and material, under normal use and service conditions. The frame is warranted for a lifetime. Parts and labor are warranted for one (1) year from the date of purchase.

This warranty extends only to the original purchaser (customer). ICON's obligation under this warranty is limited to repairing or replacing, at ICON's option, the product through one of its authorized service centers. All repairs for which warranty claims are made must be preauthorized by ICON. If the product is shipped to a service center, freight charges to and from the service center will be the customer's responsibility. If replacement parts are shipped while the product is under warranty, the customer will be responsible for a minimal handling charge. For in-home service, the customer will be responsible for a minimal trip charge. This warranty does not extend to freight damage to the product. This warranty will automatically be voided if the product is used as a store display model, if the product is purchased or transported outside the USA, if all instructions in this manual are not followed, if the product is abused or improperly or abnormally used, or if the product is used for commercial or rental purposes. No other warranty beyond that specifically set forth above is authorized by ICON.

ICON is not responsible or liable for indirect, special, or consequential damages arising out of or in connection with the use or performance of the product; damages with respect to any economic loss, loss of property, loss of revenues or profits, loss of enjoyment or use, or costs of removal or installation; or other consequential damages of any kind. Some states do not allow the exclusion or limitation of incidental or consequential damages. Accordingly, the above limitation may not apply to the customer.

The warranty extended hereunder is in lieu of any and all other warranties, and any implied warranties of merchantability or fitness for a particular purpose are limited in their scope and duration to the terms set forth herein. Some states do not allow limitations on how long an implied warranty lasts. Accordingly, the above limitation may not apply to the customer.

This warranty provides specific legal rights; the customer may have other rights that vary from state to state.

ICON Health & Fitness, Inc., 1500 S. 1000 W., Logan, UT 84321-9813