

PRO-FORM[®]

PERFORMANCE 1850

www.proform.com

Model No. PFTL20511.0

Serial No. _____

Write the serial number in the space above for reference.

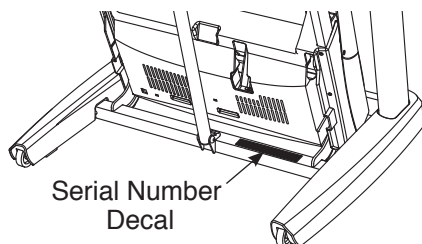

QUESTIONS?

If you have questions, or if parts are damaged or missing, **DO NOT CONTACT THE STORE**; please contact Customer Care.

IMPORTANT: Please register this product (see the limited warranty on the back cover of this manual) before contacting Customer Care.

CALL TOLL-FREE:

1-888-533-1333

Mon.–Fri. 6 a.m.–6 p.m. MT

Sat. 8 a.m.–4 p.m. MT

ON THE WEB:

www.proformservice.com

USER'S MANUAL



CAUTION

Read all precautions and instructions in this manual before using this equipment. Save this manual for future reference.

FREE

iFIT[®]



HOW-TO
VIDEOS

www.iFit.com

TABLE OF CONTENTS

WARNING DECAL PLACEMENT 2

IMPORTANT PRECAUTIONS 3

BEFORE YOU BEGIN 6

PART IDENTIFICATION CHART 7

ASSEMBLY 8

THE CHEST HEART RATE MONITOR 17

HOW TO CONNECT THE TREADMILL 18

OPERATION AND ADJUSTMENT 21

HOW TO FOLD AND MOVE THE TREADMILL 37

TROUBLESHOOTING 38

EXERCISE GUIDELINES 42

PART LIST 43

EXPLODED DRAWING 44

ORDERING REPLACEMENT PARTS Back Cover

LIMITED WARRANTY Back Cover



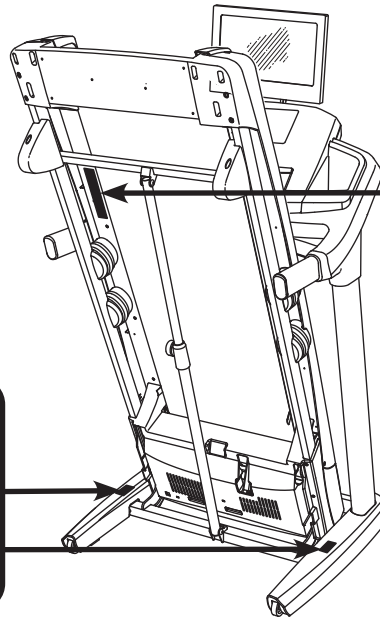

WARNING DECAL PLACEMENT

This drawing shows the locations of the warning decals. **If a decal is missing or illegible, call the telephone number on the front cover of this manual and request a free replacement decal. Apply the decal in the location shown.** Note: The decals may not be shown at actual size.



▲WARNING:

Protect yourself and others from risk of serious injury. Read the user's manual and:

-  •Stand only on the side rails when starting or stopping treadmill.
- Change speed in small increments.
- Hold handrails to prevent falling, and always wear the safety clip while operating treadmill.
- Stop if you feel faint, dizzy, or short of breath.
- Fully engage storage latch before treadmill is moved or stored.
- Reduce incline to its lowest level before folding treadmill into storage position.
-  •Never allow children on or around treadmill.
- Remove key when not in use.
-  •Keep clothing, fingers, and hair away from moving belt.
- Never try to adjust or fix the belt while it is moving.
-  •Always wear athletic shoes while operating treadmill.

IMPORTANT PRECAUTIONS

⚠️ WARNING: To reduce the risk of serious injury, read all important precautions and instructions in this manual and all warnings on your treadmill before using your treadmill. ICON assumes no responsibility for personal injury or property damage sustained by or through the use of this product.

1. Before beginning any exercise program, consult your physician. This is especially important for persons over age 35 or persons with pre-existing health problems.
2. It is the responsibility of the owner to ensure that all users of this treadmill are adequately informed of all warnings and precautions.
3. Use the treadmill only as described.
4. Keep the treadmill indoors, away from moisture and dust. Do not put the treadmill in a garage or covered patio, or near water.
5. Place the treadmill on a level surface, with at least 8 ft. (2.4 m) of clearance behind it and 2 ft. (0.6 m) on each side. Do not place the treadmill on any surface that blocks air openings. To protect the floor or carpet from damage, place a mat under the treadmill.
6. Do not operate the treadmill where aerosol products are used or where oxygen is being administered.
7. Keep children under age 12 and pets away from the treadmill at all times.
8. The treadmill should be used only by persons weighing 375 lbs. (170 kg) or less.
9. Never allow more than one person on the treadmill at a time.
10. Wear appropriate exercise clothes while using the treadmill. Do not wear loose clothes that could become caught in the treadmill. Athletic support clothes are recommended for both men and women. *Always wear athletic shoes. Never use the treadmill with bare feet, wearing only stockings, or in sandals.*
11. Plug the power cord into a surge suppressor (not included), and plug the surge suppressor into an appropriate outlet (see page 18). To avoid overloading the circuit, do not plug other electrical devices, except for low-power devices such as cell phone chargers, into the surge suppressor or into an outlet on the same circuit.
12. Use only a surge suppressor that meets all of the specifications described on page 18. To purchase a surge suppressor, see your local PROFORM dealer, call the telephone number on the front cover of this manual, or see your local electronics store.
13. Failure to use a properly functioning surge suppressor could result in damage to the control system of the treadmill. If the control system is damaged, the walking belt may slow, accelerate, or stop unexpectedly, which may result in a fall and serious injury.
14. Keep the power cord and the surge suppressor away from heated surfaces.
15. Never move the walking belt while the power is turned off. Do not operate the treadmill if the power cord or plug is damaged, or if the treadmill is not working properly. (See TROUBLESHOOTING on page 38 if the treadmill is not working properly.)
16. Read, understand, and test the emergency stop procedure before using the treadmill (see HOW TO TURN ON THE POWER on page 22).
17. Never start the treadmill while you are standing on the walking belt. Always hold the handrails while using the treadmill.
18. The treadmill is capable of high speeds. Adjust the speed in small increments to avoid sudden jumps in speed.
19. The heart rate monitor is not a medical device. Various factors, including the user's movement, may affect the accuracy of heart rate readings. The heart rate monitor is intended only as an exercise aid in determining heart rate trends in general.

20. The heart rate monitor is not a medical device. Various factors, including the user's movement, may affect the accuracy of heart rate readings. The heart rate monitor is intended only as an exercise aid in determining heart rate trends in general.
21. Never leave the treadmill unattended while it is running. Always remove the key, press the power switch into the off position (see the drawing on page 6 for the location of the power switch), and unplug the power cord when the treadmill is not in use.
22. Do not attempt to move the treadmill until it is properly assembled. (See ASSEMBLY on page 8, and HOW TO FOLD AND MOVE THE TREADMILL on page 37.) You must be able to safely lift 45 lbs. (20 kg) to move the treadmill.
23. When folding or moving the treadmill, make sure that the storage latch is holding the frame securely in the storage position.
24. Never insert any object into any opening on the treadmill.
25. Inspect and properly tighten all parts of the treadmill regularly.
26. **DANGER:** Always unplug the power cord immediately after use, before cleaning the treadmill, and before performing the maintenance and adjustment procedures described in this manual. Never remove the motor hood unless instructed to do so by an authorized service representative. Servicing other than the procedures in this manual should be performed by an authorized service representative only.
27. The treadmill is intended for home use only. Do not use the treadmill in any commercial, rental, or institutional setting.
28. Over exercising may result in serious injury or death. If you feel faint or if you experience pain while exercising, stop immediately and cool down.
29. Do not store the television in temperatures below -40° F (-40° C) or above 140° F (60° C). Do not operate the television in temperatures below 23° F (-5° C) or above 90° F (32° C).
30. To protect the treadmill and television during lightning storms, unplug the power cord from the wall outlet and disconnect the cable system. This will prevent damage due to lightning and power line surges.
31. If an outside antenna or cable system is connected, make sure that the antenna or cable system is grounded to provide some protection against voltage surges and built-up static charges. Section 810 of the National Electrical Code, ANSI/NFPA No. 70-1984, or your local codes and ordinances provide information with respect to proper grounding of the mast and supporting structure, grounding of the lead-in wire to an antenna discharge unit, size of grounding conductors, location of antenna discharge unit, connection to grounding electrodes, and requirements for the grounding electrode.
32. An outside antenna system should not be located in the vicinity of overhead power lines or other electric light or power circuits, or where it can fall into such power lines or circuits. When installing an outside antenna system, use extreme care to keep from touching such power lines or circuits, as contact with them might be fatal.
33. To reduce the risk of electric shock, do not remove the cover or the back of the television. There are no user serviceable parts inside. Refer servicing to qualified service personnel.

34. Upon completion of any service or repairs to the treadmill or the television, ask the service technician to perform safety checks to confirm that the unit is in proper operating condition.
35. Use No. 10 AWG (5.3 mm²) copper, No. 8 AWG (8.4 mm²) aluminum, No. 17 AWG (1.0 mm²) copper-clad steel or bronze wire, or larger as a ground wire.
36. Secure an antenna lead-in and ground wires to the house with stand-off insulators spaced from 4 to 6 feet (1.22 to 1.83 m) apart.
37. Mount an antenna discharge unit as close as possible to where the lead-in enters the house.
38. Use a jumper wire not smaller than No. 6 AWG (13.3 mm²) copper, or the equivalent, when a separate antenna-grounding electrode is used. See NEC Section 810-21 (j) or your local codes and ordinances.
39. Note to CATV system installer: This reminder is provided to call the CATV system installer's attention to Article 820-40 of the NEC or your local codes and ordinances that provide guidelines for proper grounding and, in particular, specifies that the cable ground shall be connected to the grounding system of the building, as close to the point of cable entry as practical.

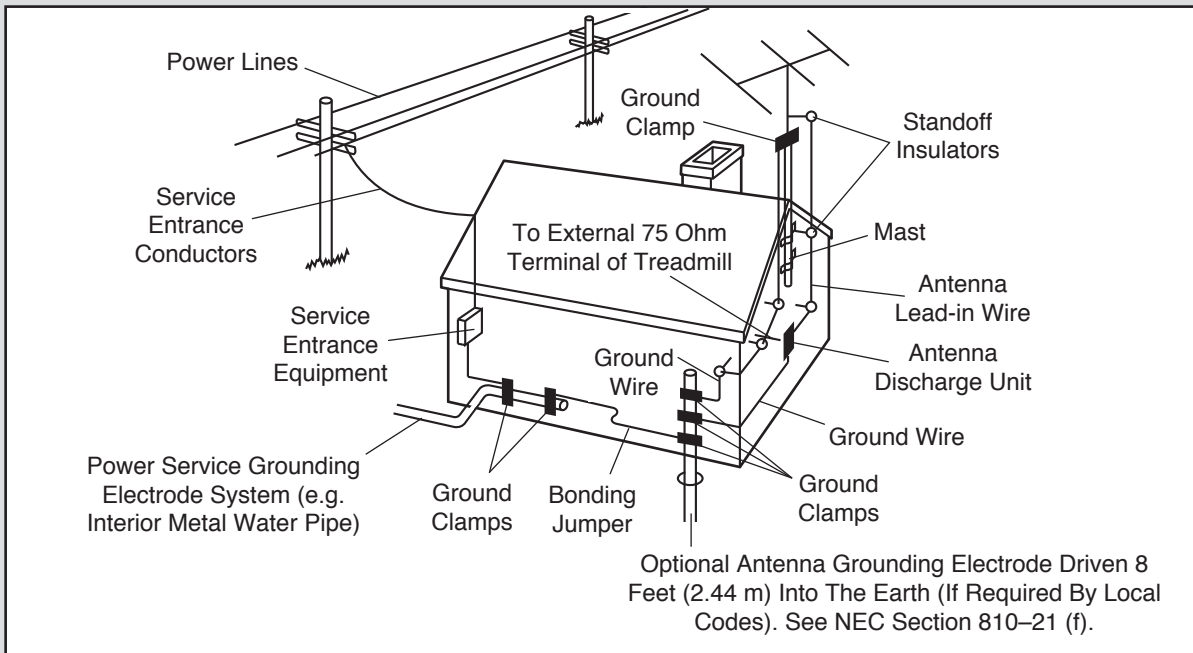

SAVE THESE INSTRUCTIONS

BEFORE YOU BEGIN

Thank you for selecting the revolutionary PROFORM® PERFORMANCE 1850 treadmill. The PERFORMANCE 1850 treadmill offers an impressive selection of features designed to make your workouts at home more enjoyable and effective. And when you're not exercising, the unique treadmill can be folded up, requiring less than half the floor space of other treadmills.

reading this manual, please see the front cover of this manual. To help us assist you, please note the product model number and serial number before contacting us. The model number and the location of the serial number decal are shown on the front cover of this manual.



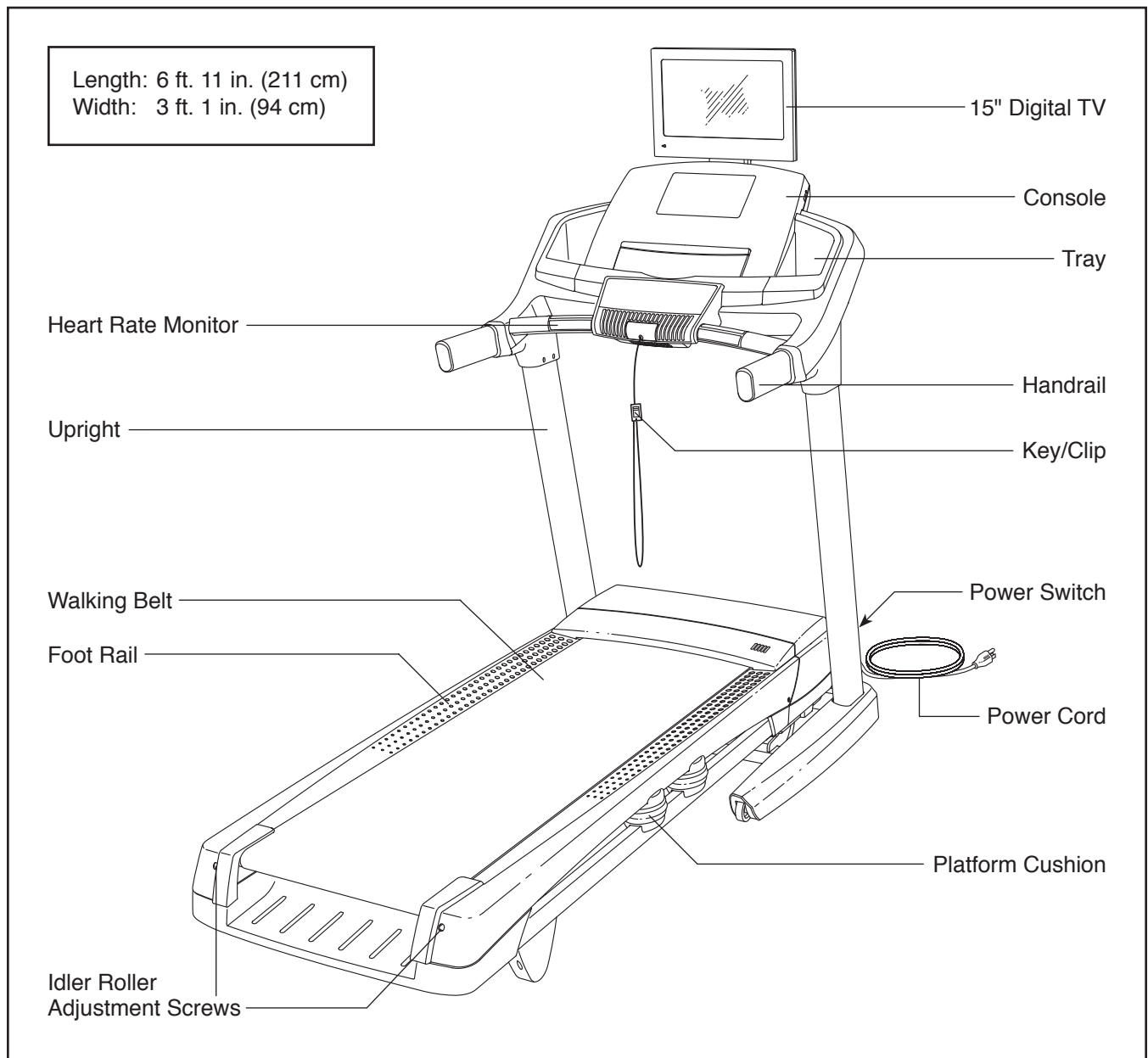

Before reading further, please review the drawing below and familiarize yourself with the labeled parts.

For your benefit, read this manual carefully before using the treadmill. If you have questions after

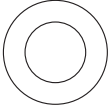

PART IDENTIFICATION CHART

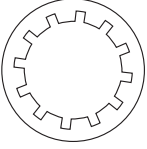
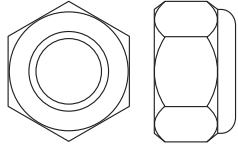
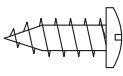
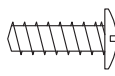
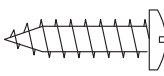
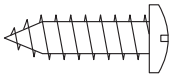
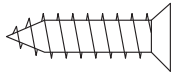

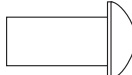
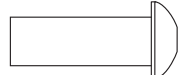
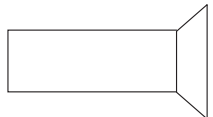
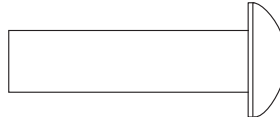
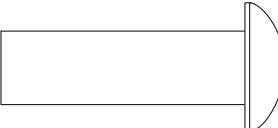
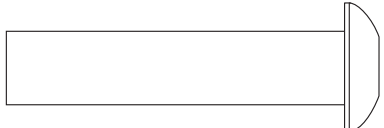
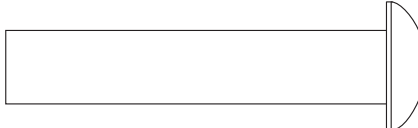
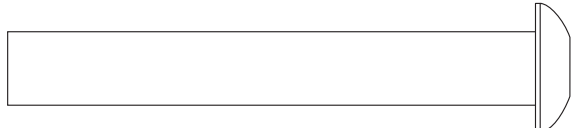

Use the drawings below to identify small parts used for assembly. The number in parentheses below each drawing is the key number of the part, from the PART LIST near the end of this manual. The number following the key number is the quantity used for assembly. **Note: If a part is not in the hardware kit, check to see if it is pre-attached. Extra hardware may be included.**

				
1/4" Star Washer (35)-6	5/16" Flat Washer (113)-4	5/16" Star Washer (11)-4	3/8" Star Washer (13)-4	3/8" Nut (12)-2
				
#8 x 1/2" Screw (1)-18	#8 x 1/2" Ground Screw (10)-1	#8 x 3/4" Screw (2)-8	#10 x 3/4" Screw (9)-2	#10 x 3/4" Flat Head Screw (112)-2
				
M4 x 12mm Screw (115)-4	1/4" x 1/2" Screw (36)-4	1/4" x 3/4" Screw (116)-4	5/16" x 1" Screw (5)-4	5/16" x 1 1/4" Bolt (4)-2
				
3/8" x 1 1/4" Screw (8)-4	3/8" x 1 3/4" Bolt (6)-1	3/8" x 2" Bolt (3)-1		
				
	3/8" x 2 3/4" Screw (7)-4			

ASSEMBLY

- To hire an authorized service technician to assemble the treadmill, call 1-800-445-2480.
- Assembly requires two persons.
- Place all parts in a cleared area and remove the packing materials. Do not dispose of the packing materials until you finish all assembly steps.
- After shipping, there may be an oily substance on the exterior of the treadmill. This is normal. If there is an oily substance on the treadmill, wipe it off with a soft cloth and a mild, non-abrasive cleaner.

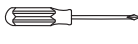
- To identify small parts, see page 7.
- Assembly requires the following tools:

- the included hex key 
- one adjustable wrench 
- one Phillips screwdriver 
- one pair of scissors 

To avoid damaging parts, do not use power tools.

1. **Make sure that the power cord is unplugged.** Place a piece of cardboard below the rear of the Frame (56) to protect the floor or carpet.

Attach the Left Wheel Cap (96) to the Base (94) with two #8 x 3/4" Screws (2).

Attach the Right Wheel Cap (not shown) to the right side of the Base (94) in the same way.

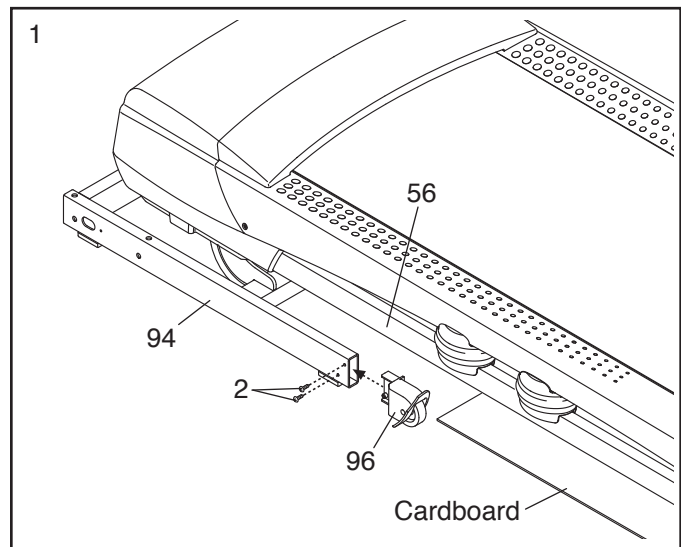

2. Pull the Upright Wire (81) and the base ground wire (A) through the indicated hole in the Base (94).

Attach the base ground wire (A) to the Base (94) with a #8 x 1/2" Ground Screw (10).

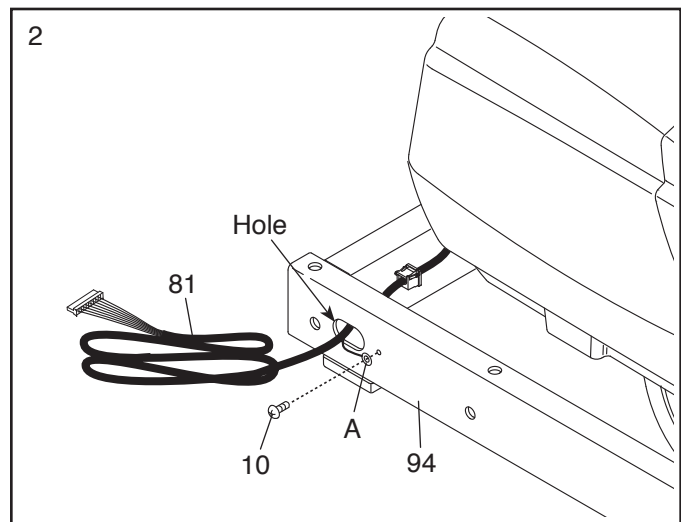

3. Identify the Left Upright (89), which is marked with a "Left" sticker or an "L" sticker. Have a second person hold the Left Upright near the Base (94).

See the inset drawing. Tie the wire tie in the Left Upright (89) securely around the end of the Upright Wire (81). Then, pull the other end of the wire tie until the Upright Wire is routed through the Left Upright.

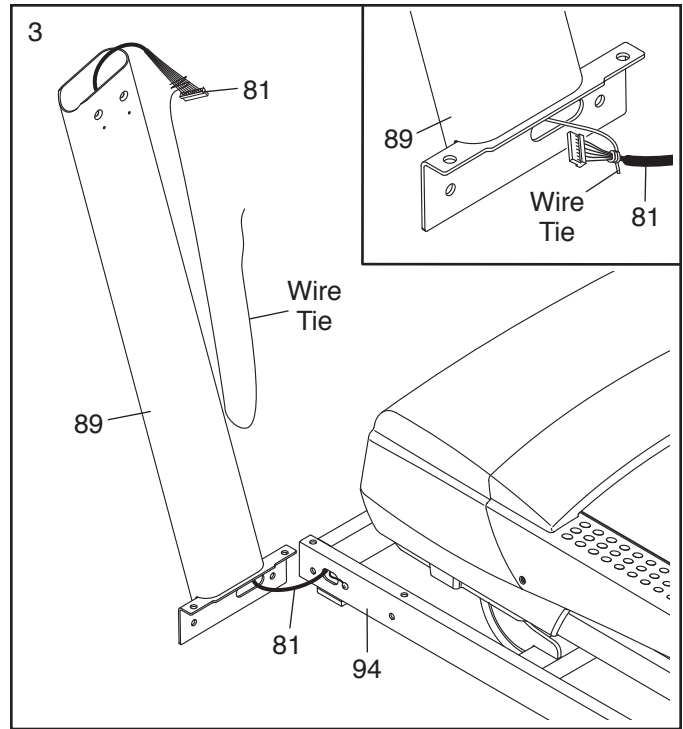

4. Hold the Left Upright (89) against the Base (94). **Be careful not to pinch the Upright Wire (81).** Insert two 3/8" x 1 1/4" Screws (8) with two 3/8" Star Washers (13) and two 3/8" x 2 3/4" Screws (7) into the Left Upright.

Partially tighten the 3/8" x 2 3/4" Screws (7) and the 3/8" x 1 1/4" Screws (8) until the heads of the Screws touch the Left Upright (89); **do not fully tighten the Screws yet.** Note: It may be helpful to use the Short Hex Key (64) on the Screw shown.

Attach the Right Upright (not shown) in the same way. Note: There is a coaxial cable in the Right Upright.

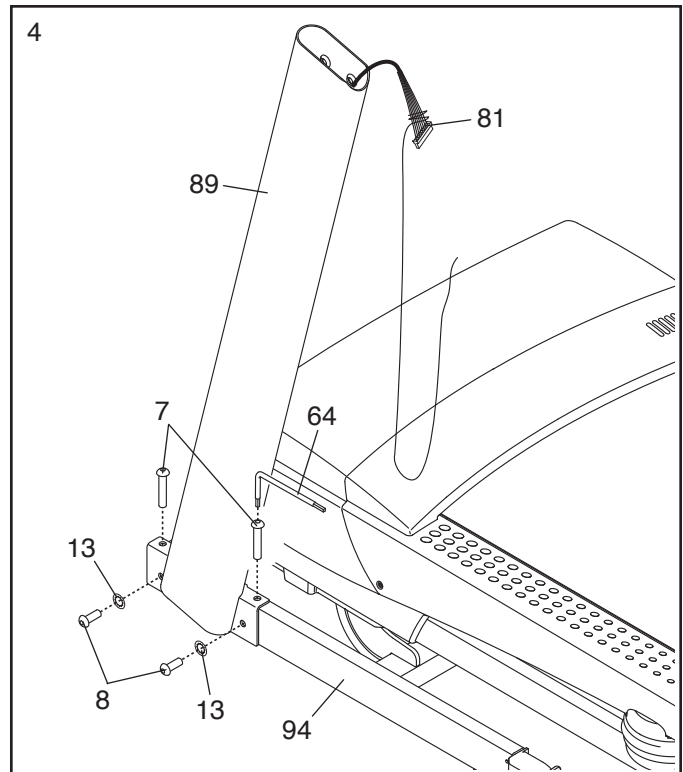

5. Identify the Left Base Cover (82) and the Right Base Cover (83). Slide the Left Base Cover onto the Left Upright (89). Slide the Right Base Cover onto the Right Upright (90). **Do not press the Base Covers into place yet.**

Identify the Left Upright Cover (79) and the Right Upright Cover (80). Slide the Left Upright Cover onto the Left Upright (89). Slide the Right Upright Cover onto the Right Upright (90).

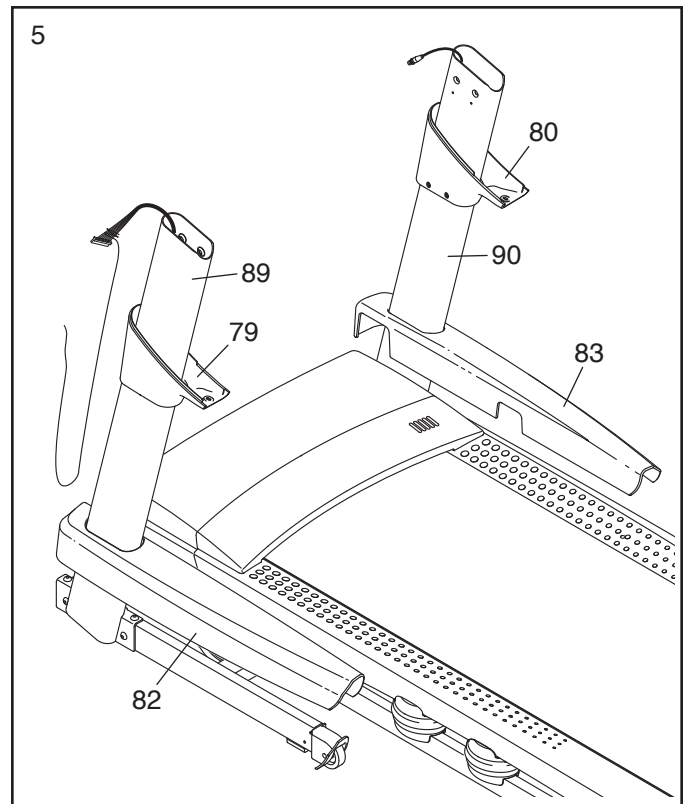

6. Cut the plastic ties in the Left Handrail (88) and the Right Handrail (87). If necessary, press the 5/16" Cage Nuts (31) back into place.

Identify the Left Handrail (88) and hold it near the Left Upright (89). Insert the Upright Wire (81) through the bracket on the bottom of the Left Handrail. Pull the Upright Wire out of the end of the Left Handrail.

Hold the Right Handrail (87) near the Right Upright (90). Insert the Upright Coaxial Cable (122) through the bracket on the bottom of the Right Handrail. Pull the Upright Coaxial Cable out of the end of the Right Handrail.

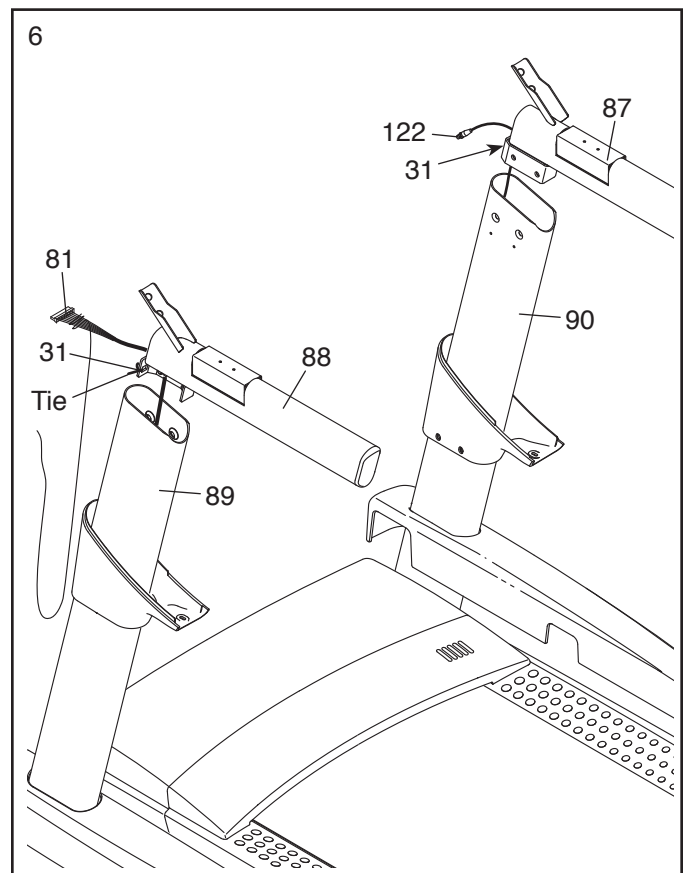

7. Attach the Left Handrail (88) to the Left Upright (89) with two 5/16" x 1" Screws (5), two 5/16" Star Washers (11), and a 5/16" x 1 1/4" Bolt (4). **Do not tighten the Screws and Bolt yet.**

Attach the Right Handrail (87) in the same way.

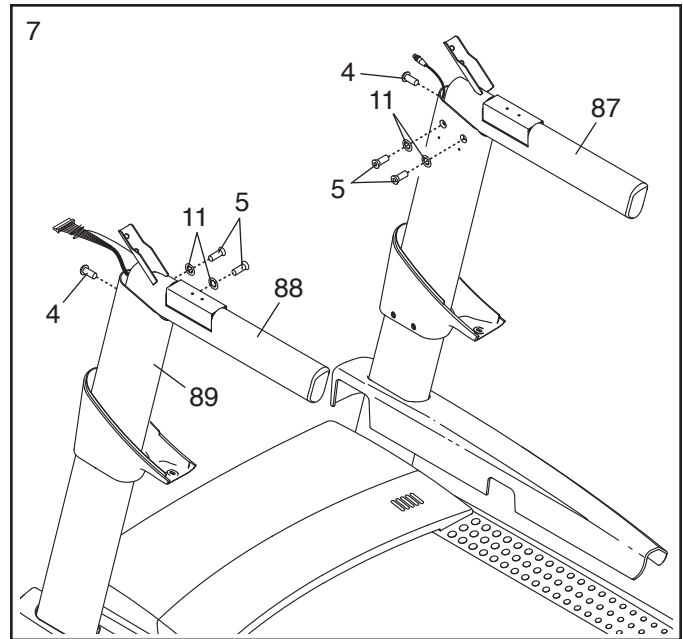

8. Set the console assembly face down on a soft surface to avoid scratching the console assembly.

Remove all of the screws (B) attaching the Crossbar (93). Next, lift off the Crossbar. Discard the Screws.

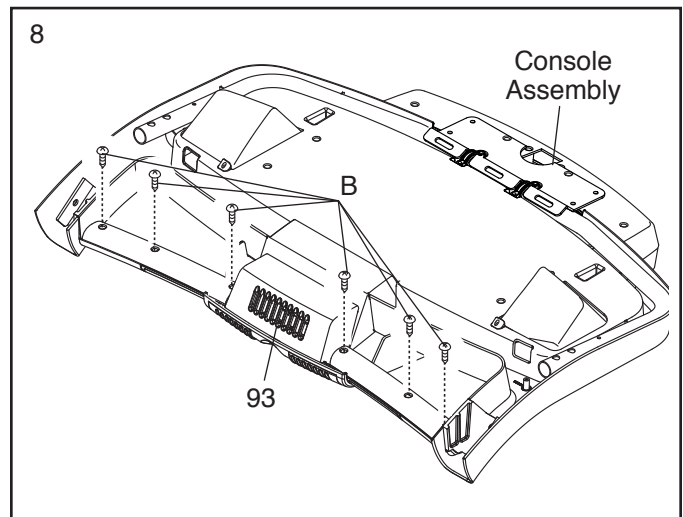

9. **IMPORTANT: To avoid damaging the Crossbar (93), do not use power tools and do not overtighten the #10 x 3/4" Screws (9) or the #10 x 3/4" Flat Head Screws (112).**

Orient the Crossbar (93) as shown. Attach the Crossbar to the Handrails (87, 88) with two #10 x 3/4" Flat Head Screws (112), two #10 x 3/4" Screws (9), and two 1/4" Star Washers (35) as shown. **Start all four Screws, and then tighten them.**

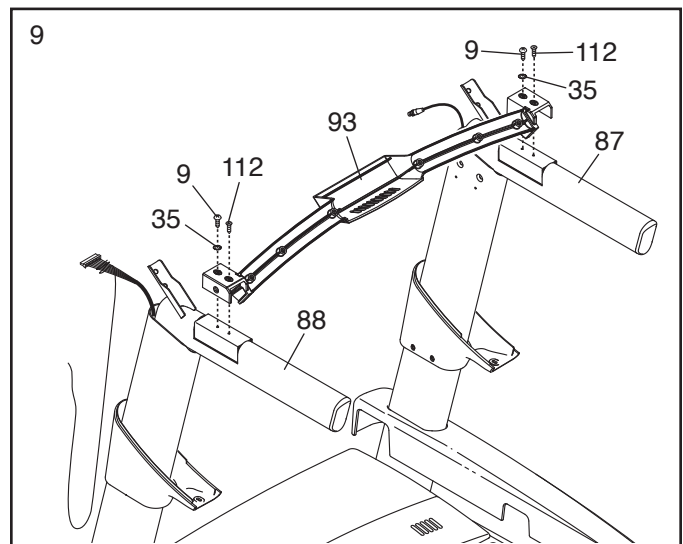

10. With the help of a second person, hold the console assembly near the Left Handrail (88).

Connect the Upright Wire (81) to the console wire. **See the inset drawing. The connectors should slide together easily and snap into place.** If they do not, turn one connector and try again. **IF YOU DO NOT CONNECT THE CONNECTORS PROPERLY, THE CONSOLE MAY BECOME DAMAGED WHEN YOU TURN ON THE POWER.** Remove the wire tie from the Upright Wire.

Connect the Upright Coaxial Cable (not shown) in the Right Upright (not shown) to the cable from the console assembly.

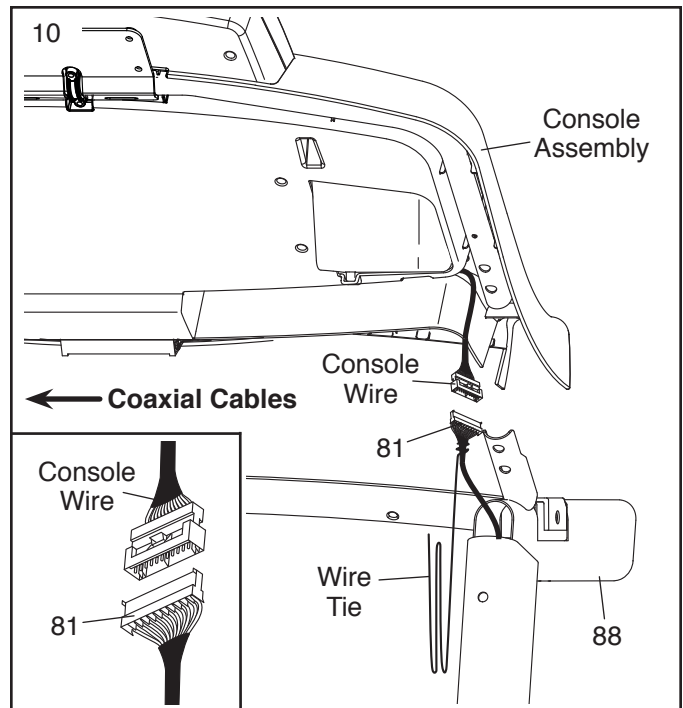

11. Set the console assembly on the Right Handrail (87) and the Left Handrail (88). **Be careful not to pinch any wires.** Insert the excess wires (not shown) into the Handrails.

Attach the console assembly with six #8 x 1/2" Screws (1) and four 1/4" x 1/2" Screws (36) with four 5/16" Flat Washers (113) and four 1/4" Star Washers (35) as shown. **Start all ten Screws, and then tighten them.**

See step 7. Tighten the four 5/16" x 1" Screws (5) and the two 5/16" x 1 1/4" Bolts (4).

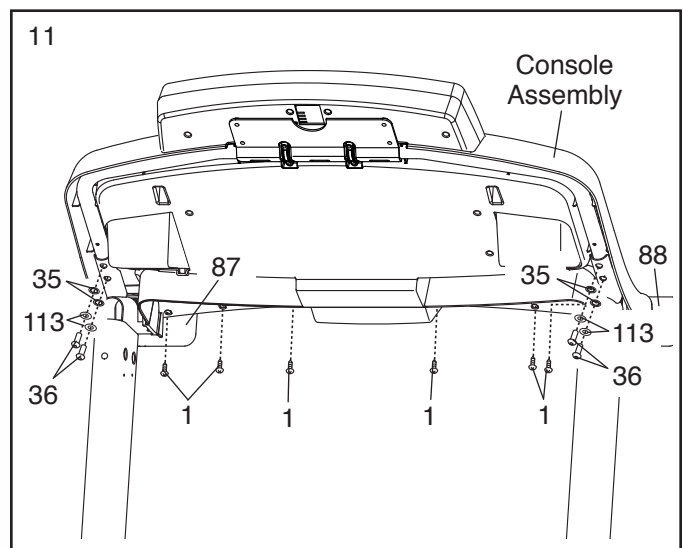

12. Tighten the four 3/8" x 2 3/4" Screws (7) first and then the four 3/8" x 1 1/4" Screws (8) (only one side is shown).

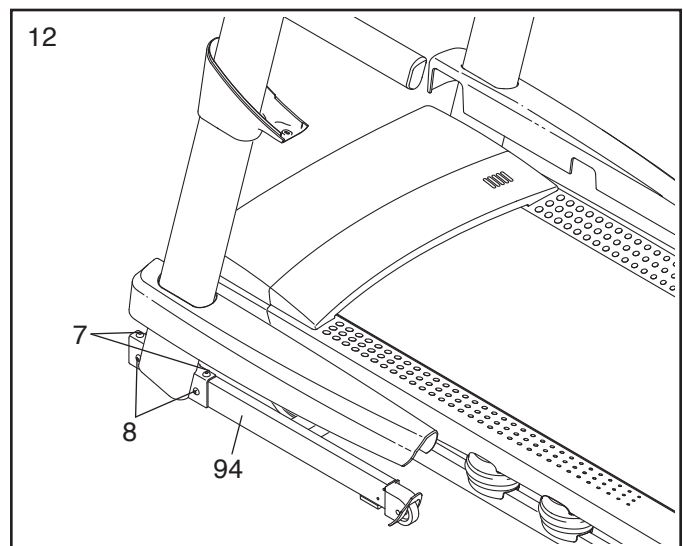

13. Slide the Left Handrail Cover (85) onto the Left Handrail (88). Slide the Right Handrail Cover (86) onto the Right Handrail (87). Attach each Handrail Cover with a #8 x 1/2" Screw (1).

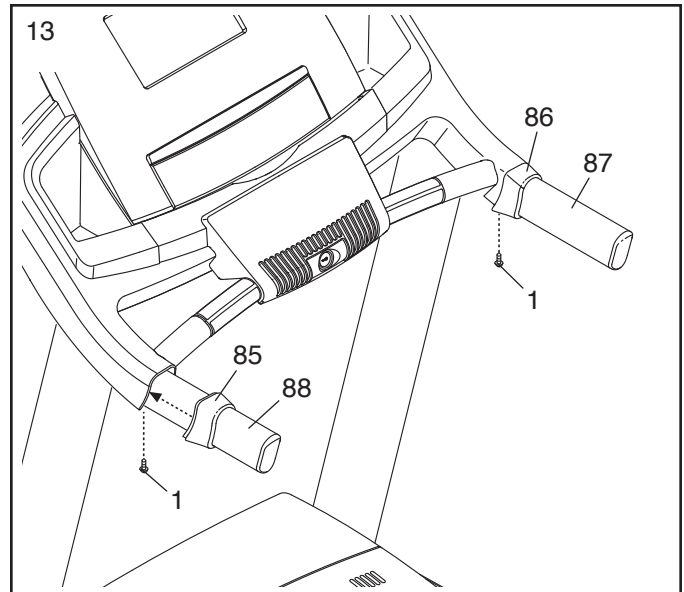

14. Hold the Left Upright Cover (79) against the console assembly. Align the holes in the Left Upright Cover with the holes in the Left Upright (89). Attach the Left Upright Cover with three #8 x 1/2" Screws (1).

Attach the Right Upright Cover (80) to the Right Upright (90) in the same way.

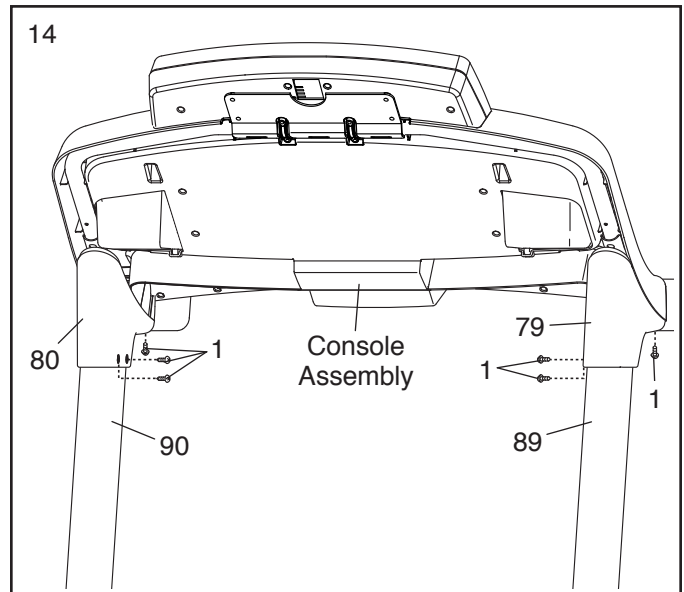

15. Attach the Left Tray (107) and the Right Tray (108) to the console assembly with four #8 x 1/2" Screws (1).

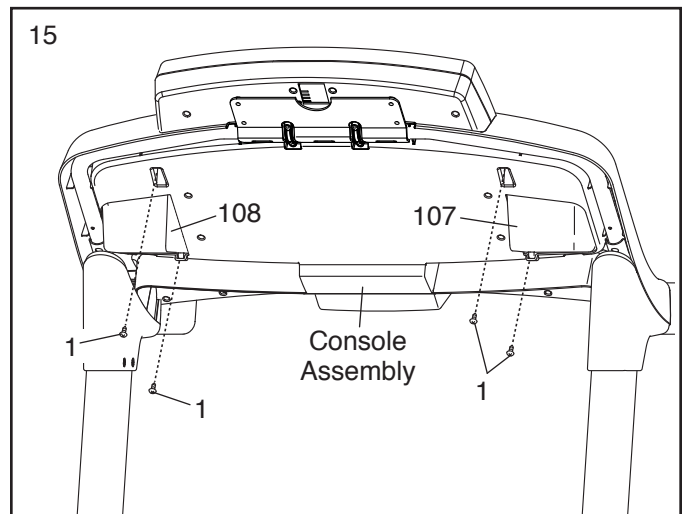

16. **IMPORTANT:** See page 18 and plug in the power cord. Next, see page 22 and turn on the power.

See page 30; follow steps 1, 2, and 4.

When the frame stops moving, remove the key from the console and unplug the power cord.

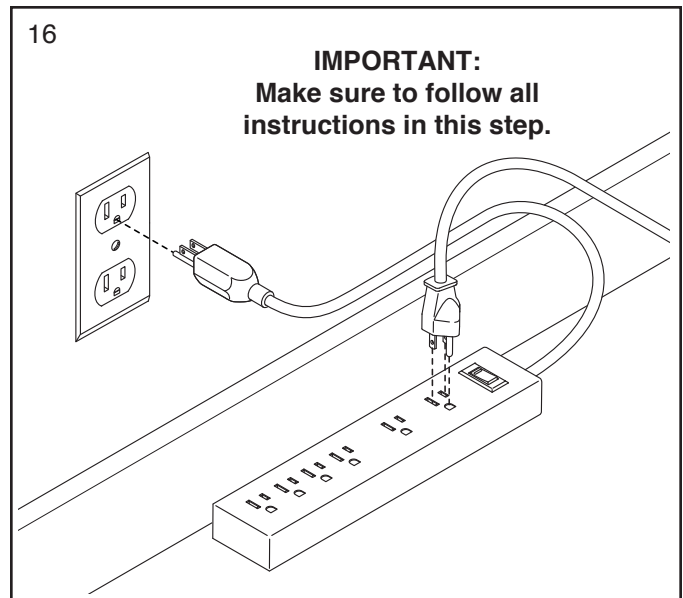

17. **IMPORTANT:** Before you begin this step, make sure that you have read and followed all of the instructions in step 16.

Raise the Frame (56) to the position shown. **Have a second person hold the Frame until this step is completed.**

Orient the Storage Latch (53) so that the large barrel and the latch knob are oriented as shown; **make sure that the caps remain in the ends of the Storage Latch.**

Attach the lower end of the Storage Latch (53) to the Base (94) with a 3/8" x 2" Bolt (3) and a 3/8" Nut (12).

Attach the upper end of the Storage Latch (53) to the bracket on the Frame (56) with a 3/8" x 1 3/4" Bolt (6) and a 3/8" Nut (12).

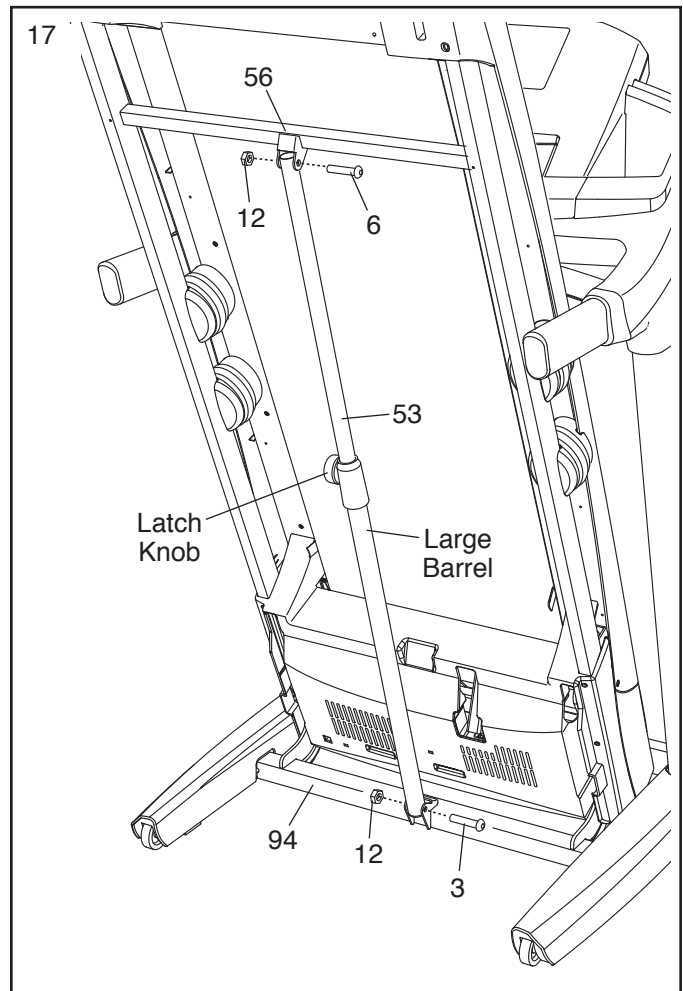

18. Attach the Rear Feet (57) to the Frame (56) as shown with four #8 x 3/4" Screws (2).

Lower the Frame (56) (see HOW TO LOWER THE TREADMILL FOR USE on page 37).

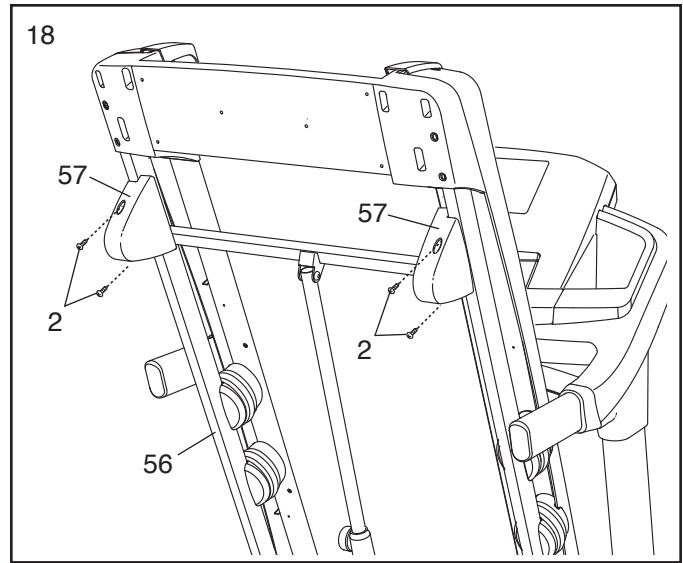

19. Press the Grommet (77) into the square hole in the Base (94).

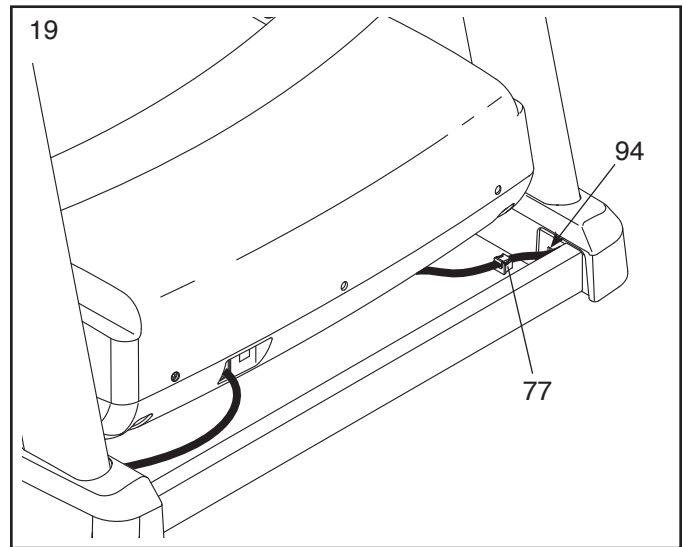

20. Remove the #8 x 1/2" Machine Screw (114) and the Wire Cover (117) from the TV Bracket (118).

With the help of a second person, hold the TV (119) near the TV Bracket (118) and insert the wires from the TV down through the indicated Cable Tie (99).

Attach the TV (119) to the TV Bracket (118) with four M4 x 12mm Screws (115). **Start all four Screws before tightening them.**

Carefully pull the wires tight, and then tighten the Cable Tie (99) around the wires.

Re-attach the Wire Cover (117) with the #8 x 1/2" Machine Screw (114).

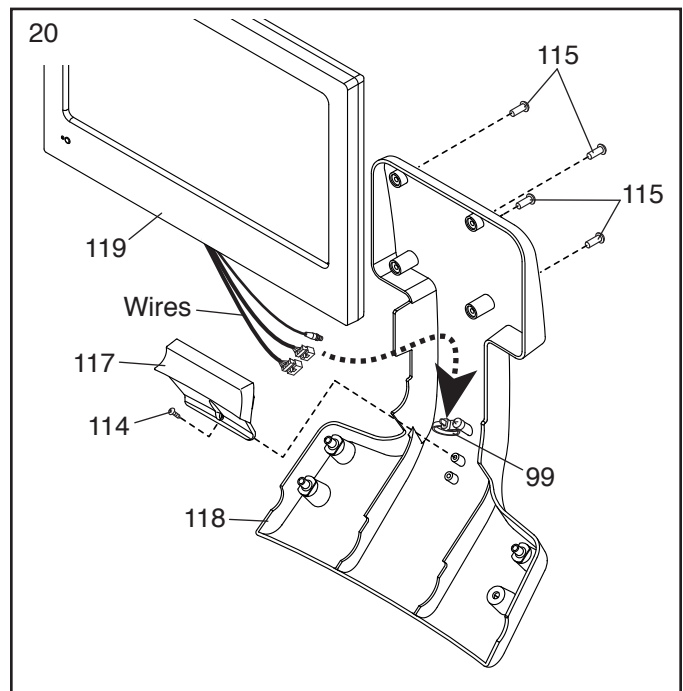

21. With the help of a second person, hold the TV assembly near the console assembly, and connect the wires.

Attach the TV assembly to the back of the console assembly with four 1/4" x 3/4" Screws (116). **Be careful not to pinch any wires. Start all four Screws, and then tighten them.**

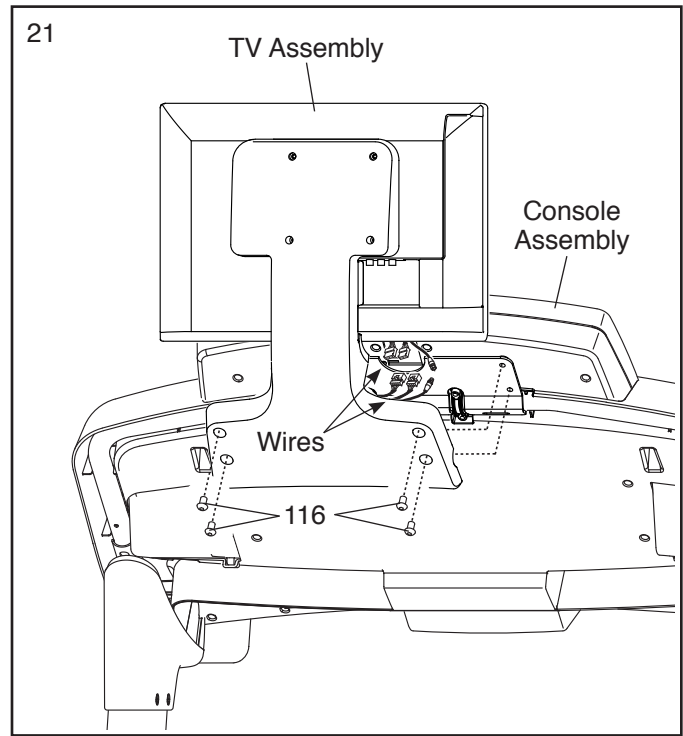

22. Place the treadmill near the coaxial cable from your wall (or device). Connect the coaxial cable to the Upright Coaxial Cable (122).

Press the Right Base Cover (83) and the Left Base Cover (not shown) onto the Base (94) until they snap into place.

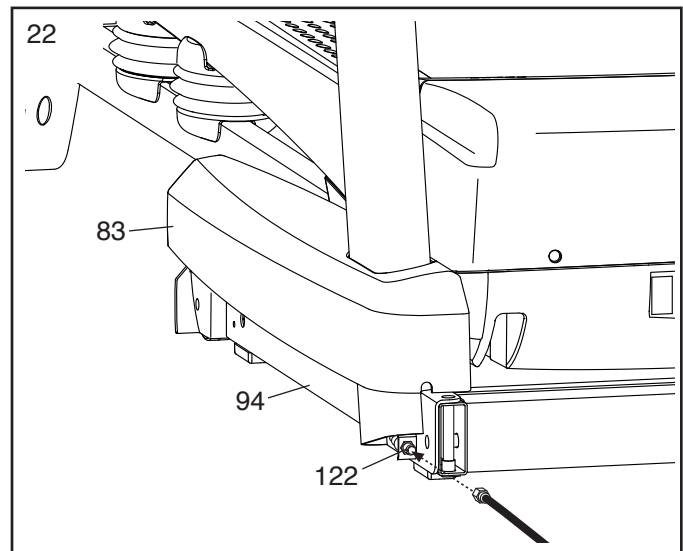

23. **Make sure that all parts are properly tightened before you use the treadmill.** If there are sheets of plastic on the treadmill decals, remove the plastic. To protect the floor or carpet, place a mat under the treadmill.
Note: Extra hardware may be included. Keep the included hex keys in a secure place; one of the hex keys is used to adjust the walking belt (see pages 39 and 40).

THE CHEST HEART RATE MONITOR

HOW TO PUT ON THE HEART RATE MONITOR

The heart rate monitor consists of a chest strap and a sensor. Insert the tab on one end of the chest strap into the hole in one end of the sensor as shown. Then, press the end of the sensor under the buckle on the chest strap. The tab should be flush with the front of the sensor.

The heart rate monitor must be worn under your clothes, tight against your skin. Wrap the heart rate monitor around your chest in the location shown. Make sure that the logo is right-side-up. Then, attach the other end of the chest strap to the sensor. Adjust the length of the chest strap, if necessary.

Pull the sensor away from your body a few inches and locate the two electrode areas, which are covered by shallow ridges. Using saline solution such as saliva or contact lens solution, wet the electrode areas. Then, return the sensor to a position against your chest.

CARE AND MAINTENANCE

- Thoroughly dry the sensor with a soft towel after each use. Moisture may keep the sensor activated, shortening the life of the battery.
- Store the heart rate monitor in a warm, dry place. Do not store the heart rate monitor in a plastic bag or other container that may trap moisture.

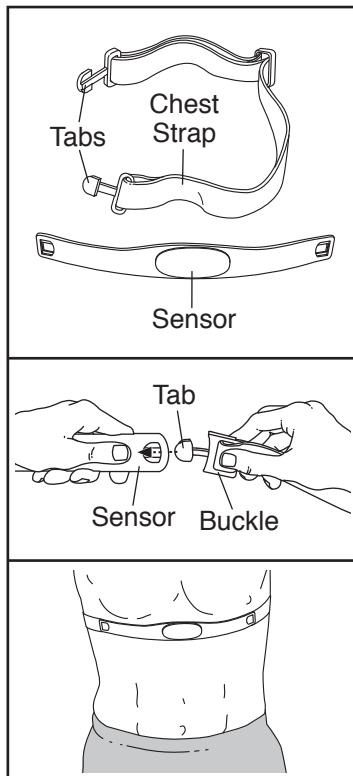

- Do not expose the heart rate monitor to direct sunlight for extended periods of time; do not expose it to temperatures above 122° F (50° C) or below 14° F (-10° C).
- Do not excessively bend or stretch the sensor when using or storing the heart rate monitor.
- To clean the sensor, use a damp cloth and a small amount of mild soap. Then, wipe the sensor with a damp cloth and thoroughly dry it with a soft towel. Never use alcohol, abrasives, or chemicals to clean the sensor. Hand wash and air dry the chest strap.

TROUBLESHOOTING

If the heart rate monitor does not function properly, try the steps below.

- Make sure that you are wearing the heart rate monitor as described at the left. If the heart rate monitor does not function when positioned as described, move it slightly lower or higher on your chest.
- If heart rate readings are not displayed until you begin perspiring, rewet the electrode areas.
- For the console to display heart rate readings, you must be within arm's length of the console.
- If there is a battery cover on the back of the sensor, replace the battery with a new battery of the same type.
- The heart rate monitor is designed to work with people who have normal heart rhythms. Heart rate reading problems may be caused by medical conditions such as premature ventricular contractions (pvc's), tachycardia bursts, and arrhythmia.
- The operation of the heart rate monitor can be affected by magnetic interference from high power lines or other sources. If you suspect that magnetic interference is causing a problem, try relocating the fitness equipment.

HOW TO CONNECT THE TREADMILL

HOW TO CONNECT THE POWER CORD

Use a Surge Suppressor

Your treadmill, like other electronic equipment, can be damaged by sudden voltage changes in your home's power. Voltage surges, spikes, and noise interference can result from weather conditions or from other appliances being turned on or off. **To decrease the risk of damaging the treadmill, always use a surge suppressor with the treadmill. To purchase a surge suppressor, see precaution 12 on page 3.**

Use only a surge suppressor that is UL 1449 listed as a transient voltage surge suppressor (TVSS). The surge suppressor must have a UL suppressed voltage rating of 400 volts or less and a minimum surge dissipation of 450 joules. The surge suppressor must also be electrically rated for 120 volts AC and 15 amps. There must be a monitoring light on the surge suppressor to indicate whether it is functioning properly. **Failure to use a properly functioning surge suppressor could result in damage to the control system of the treadmill and serious injury to users.**

Plug in the Power Cord

The treadmill must be grounded. If it should malfunction or break down, grounding provides a path of least resistance for electric current to reduce the risk of electric shock. The treadmill power cord has a plug with a grounding pin (see drawing 1 on this page).

⚠ DANGER: Improper connection of the power cord increases the risk of electric shock. Do not modify the plug—if it will not fit an outlet, have a proper outlet installed by a qualified electrician. If you are unsure whether the treadmill is properly grounded, contact a qualified electrician.

Plug the power cord into a surge suppressor, and plug the surge suppressor into an appropriate outlet that is properly installed and grounded in accordance with all local codes and ordinances. **The outlet must be on a**

nominal 120-volt circuit capable of carrying 15 or more amps. To avoid overloading the circuit, do not plug other electrical devices, except for low-power devices such as cell phone chargers, into the surge suppressor or into an outlet on the same circuit. **IMPORTANT: The treadmill is not compatible with GFCI-equipped outlets and may not be compatible with AFCI-equipped outlets.**

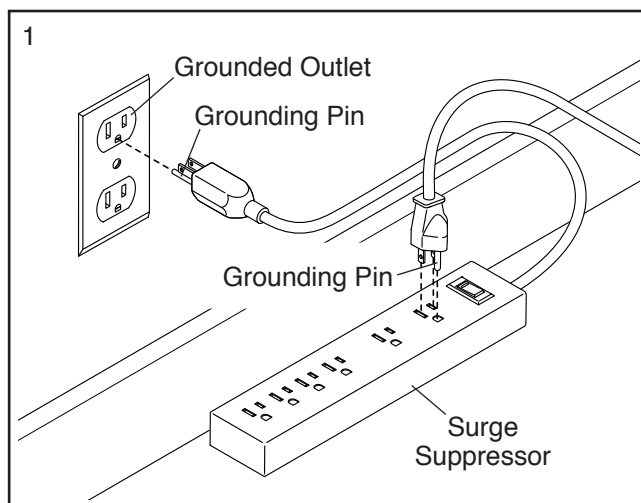

A temporary adapter may be used to connect the surge suppressor to a 2-pole receptacle if a properly grounded outlet is not available.

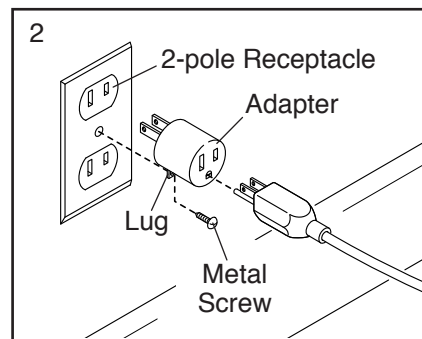

The lug or wire extending from the adapter must be connected with a metal screw to a permanent ground such as a properly grounded outlet box cover. **Some 2-pole receptacle outlet box covers are not grounded. Before using an adapter, contact a qualified electrician to determine whether the outlet box cover is grounded. The temporary adapter should be used only until a properly grounded outlet can be installed by a qualified electrician.**

Before operating the 15" digital TV, you must connect an antenna or a 75 ohm CATV cable to the 75 ohm terminal, an AV cable to the audio/video input jack, or an HDMI cable to the HDMI input jack. Note: Use a CATV cable to connect to an external source such as a cable box, satellite TV box, VCR, or analog cable. No CATV cable, antenna, or adapter; AV cable; or HDMI cable is included.

HOW TO CONNECT AN ANTENNA

Place an indoor VHF antenna or an outdoor combination VHF/UHF antenna in the desired location. Outdoor antennas are subject to weathering that can reduce signal quality. Inspect your outdoor antenna and the lead-in wiring before connecting the antenna.

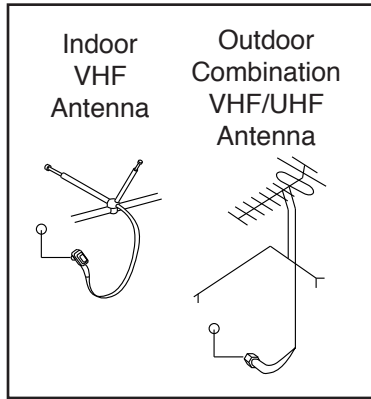

2. Push the 300 ohm to 75 ohm adapter onto the 75 ohm terminal on the treadmill frame near the power cord.

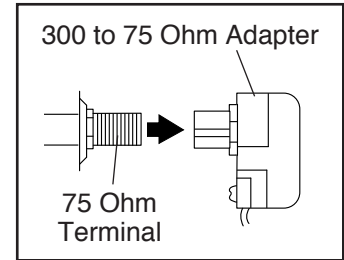

Note: Due to an FCC requirement, analog signals are no longer broadcast over the air in the United States as of June 12, 2009. If you wish to view television signals through an antenna, you must have an antenna capable of receiving digital signals. Cable television has not been affected.

75 Ohm CATV Cable

1. Connect the 75 ohm CATV cable from the antenna to the 75 ohm terminal on the treadmill frame near the power cord.

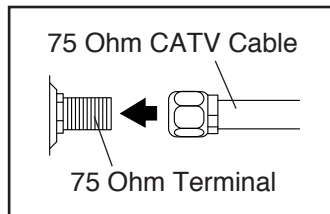

HOW TO CONNECT AN EXTERNAL SOURCE USING A CATV CABLE

1. Connect one end of a 75 ohm CATV cable to the 75 ohm output jack on your external source.
2. Plug in the power cord of your external source. See your external source's user's manual for proper grounding instructions.
3. Connect the 75 ohm CATV cable to the 75 ohm terminal on the treadmill frame near the power cord. See the drawing at the left.

300 Ohm Flat Wire

1. Connect the 300 ohm flat wire from the antenna to a 300 ohm to 75 ohm adapter.

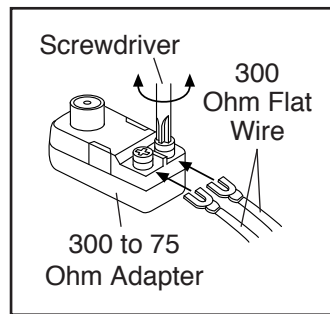

HOW TO CONNECT A VCR, DVD PLAYER, OR OTHER DEVICE USING AN AV CABLE

1. Connect the three-pronged end of an RCA AV Cable to your VCR, DVD player, or other device.
2. Plug in the power cord of your device. See your VCR, DVD player, or other device's user's manual for proper grounding instructions.
3. Connect the RCA AV Cable to the audio/video input jack on the 15" digital TV as shown below.
4. To use the tie blocks, see step 4 at the right.
Note: Only use the tie blocks after you have connected all desired cables.

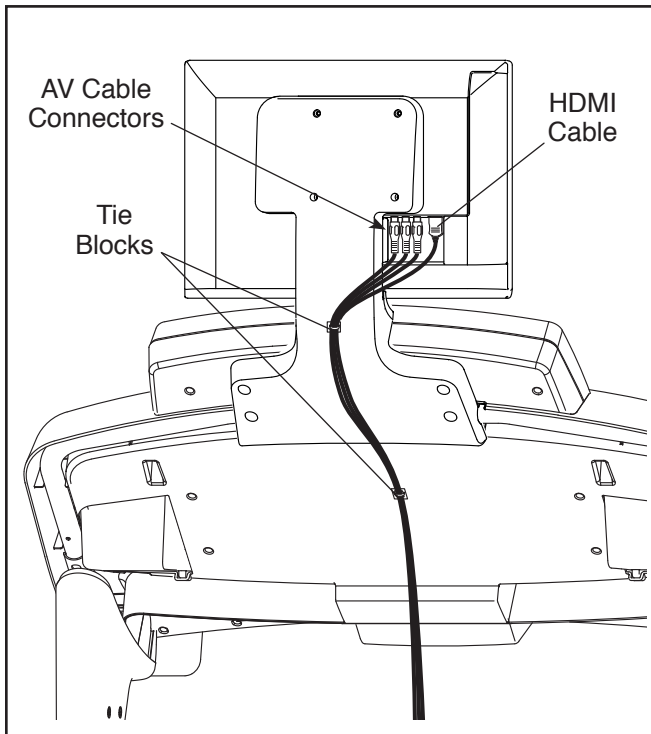

HOW TO CONNECT A DVD OR BLU-RAY PLAYER OR OTHER DEVICE USING AN HDMI CABLE

1. Connect one end of an HDMI Cable to your DVD or Blu-ray player or other device.
2. Plug in the power cord of your device. See your DVD or Blu-ray player or other device's user's manual for proper grounding instructions.
3. Connect the other end of the HDMI Cable to the HDMI input jack on the 15" digital TV as shown at the left.
4. If desired, apply the included tie blocks as shown at the left. First, remove the paper covering the adhesive on the back of a tie block. Then, apply the adhesive on the tie block in the location desired. Wrap one of the included zip ties through the tie block and around the wires. Then, pull the zip tie on the tie block to secure the wires. Cut the end of the zip tie. Repeat this step with as many tie blocks as desired.

IMPORTANT: Do not plug any devices into the USB port on the side of the 15" digital TV.

OPERATION AND ADJUSTMENT

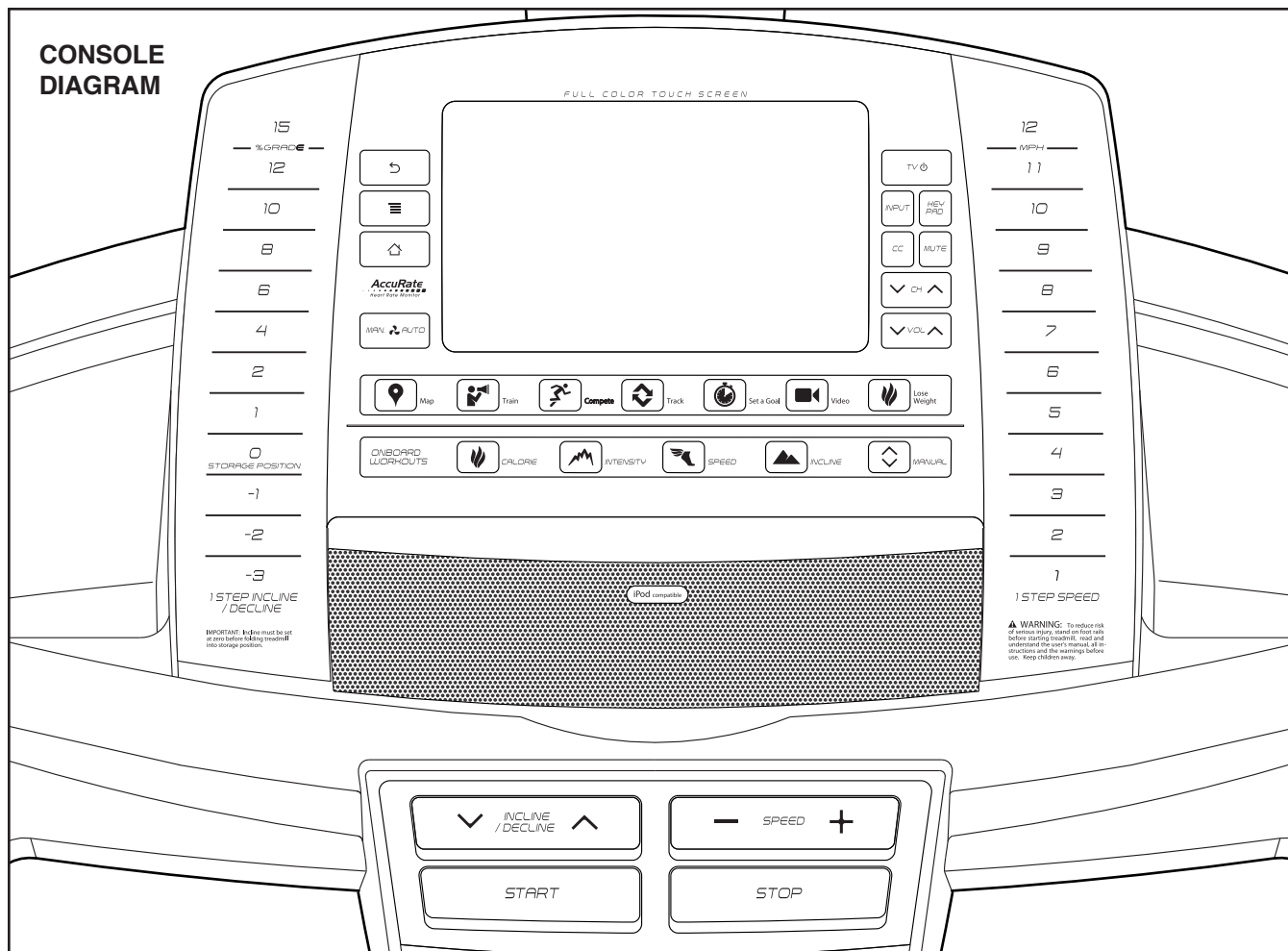

FEATURES OF THE CONSOLE

The treadmill console offers an impressive array of features designed to make your workouts more effective and enjoyable. The console features revolutionary iFit Live technology that enables the treadmill to communicate with your wireless network. With iFit Live technology, you can download personalized workouts, create your own workouts, track your workout results, and access many other features. **See www.iFit.com for complete information.**

In addition, the console features a selection of onboard workouts, including eight calorie workouts, eight intensity workouts, eight speed workouts, eight incline workouts, and six iFit Live demo workouts. Each workout automatically controls the speed and incline of the treadmill as it guides you through an effective exercise session. In addition, you can set a calorie, time, distance, or pace goal.

When you use the manual mode, you can change the speed and incline of the treadmill with the touch of a button.

As you exercise, the console will display instant exercise feedback. You can also measure your heart rate using the handgrip heart rate monitor or the chest heart rate monitor.

You can even browse the Internet or listen to your favorite workout music or audio books with the console's stereo sound system while you exercise.

To turn on the power, see page 22. To learn how to use the touch screen, see page 22. To set up the console, see page 23.

Note: The console can display speed and distance in either miles or kilometers. To find which unit of measurement is selected, see step 4 on page 29. For simplicity, all instructions in this section refer to miles.

HOW TO TURN ON THE POWER

IMPORTANT: If the treadmill has been exposed to cold temperatures, allow it to warm to room temperature before you turn on the power. If you do not do this, you may damage the console display or other electrical components.

Plug in the power cord (see page 18). Next, locate the power switch on the treadmill frame near the power cord. Make sure that the switch is in the reset position.

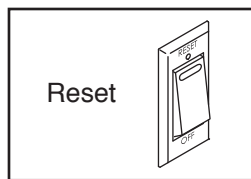

IMPORTANT: The console features a display demo mode, designed to be used if the treadmill is displayed in a store. If the demo mode is turned on, the display will show a demo presentation after you plug in the power cord and press the power switch into the reset position, before you insert the key. To turn off the demo mode, see step 6 on page 29.

Next, stand on the foot rails of the treadmill. Locate the clip attached to the key, and slide the clip securely onto the waistband of your clothes. Then, insert the key into the console. **IMPORTANT:**

In an emergency, the key can be pulled from the console, causing the walking belt to slow to a stop. Test the clip by carefully taking a few steps backward; if the key is not pulled from the console, adjust the position of the clip.

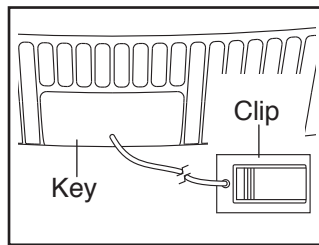

Note: It may take a minute for the console to be ready for use.

HOW TO USE THE TOUCH SCREEN

The console features a tablet with a full-color touch screen. The following information will help you become familiar with the tablet's advanced technology:

- The console functions similarly to other tablets. You can slide or flick your finger against the screen to move certain images on the screen, such as the displays in a workout (see step 5 on page 24). However, you cannot zoom in and out by sliding your fingers on the screen.
- The screen is not pressure sensitive. You do not need to press hard on the screen.
- To type information into a text box, touch the text box to view the keyboard. To use numbers or other characters on the keyboard, touch the ?123 button. To view more characters, touch the Alt button. Touch the Alt button again to return to the number keyboard. To return to the letter keyboard, touch the ABC button. To use a capital character, touch the button with an upward-facing arrow. To use multiple capital characters, touch the arrow button again. To return to the lowercase keyboard, touch the arrow button a third time. To clear the last character, touch the button with a backward-facing arrow and an X.

- Use the buttons on the console shown to navigate the tablet. Press the Back button to return to the previous screen. Press the Home button to return to the main menu. Note: The center button does not function.

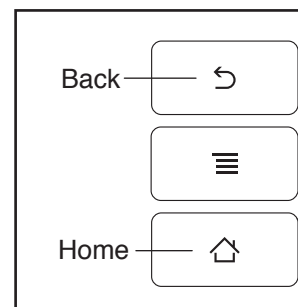

HOW TO SET UP THE CONSOLE

Before using the treadmill for the first time, set up the console.

1. Connect to your wireless network.

Note: In order to access the Internet, download iFit Live workouts, and use several other features of the console, you must be connected to a wireless network. See HOW TO USE THE WIRELESS NETWORK MODE on page 31 to connect the console to your wireless network.

2. Check for firmware updates.

First, see step 1 on page 29 and step 2 on page 30 and select the maintenance mode. Then, see step 3 on page 30 and check for firmware updates.

3. Calibrate the incline system.

See step 4 on page 30 and calibrate the incline system of the treadmill (unless you already did so during assembly).

4. Create an iFit Live account.

Touch the globe button near the lower-left corner of the screen and touch the iFit Live button.

Note: For information about navigating in the browser, see page 32. The browser will open to the iFit.com home page. Touch the Register button in the upper-right corner of the screen.

The browser will open to the iFit.com registration page. Select either the basic or the limitless plan. Note: For more information, read the details under each plan. If you have an activation code, select the limitless plan. Then, follow the prompts on the screen to sign up for your iFit plan.

The console is now ready for you to begin working out. The following pages explain the various workouts and other features that the console offers.

To use the manual mode, see page 24. **To use an onboard workout**, see page 26. **To use a set-a-goal workout**, see page 27. **To use an iFit Live workout**, see page 28.

To use the equipment settings mode, see page 29. **To use the maintenance mode**, see page 30. **To use the wireless network mode**, see page 31. **To use the stereo sound system**, see page 32. **To use the Internet browser**, see page 32.

IMPORTANT: If there are sheets of plastic on the console, remove the plastic. To prevent damage to the walking platform, wear clean athletic shoes while using the treadmill. The first time you use the treadmill, observe the alignment of the walking belt, and center the walking belt if necessary (see page 40).

HOW TO USE THE MANUAL MODE

1. Insert the key into the console.

See HOW TO TURN ON THE POWER on page 22. **Note: It may take a minute for the console to be ready for use.**

2. Select the main menu.

When you turn on the power, the main menu will appear after the console boots up. Touch the home button in the lower-left corner of the screen (not shown here) to return to the main menu at any time.

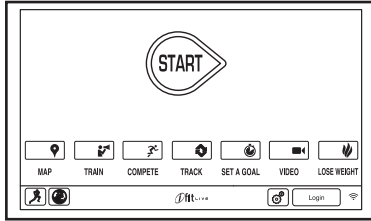

3. Start the walking belt and adjust the speed.

Touch the Start button on the screen or press the Start button on the console to start the walking belt. You can also press the Manual button on the console, and then touch the Resume button on the screen. The walking belt will begin to move at 1 mph. As you exercise, change the speed of the walking belt as desired by pressing the Speed increase and decrease buttons. Each time you press one of the buttons, the speed setting will change by 0.1 mph; if you hold down the button, the speed setting will change in increments of 0.5 mph.

If you press one of the numbered 1 Step Speed buttons, the walking belt will gradually change speed until it reaches the selected speed setting. To select a speed setting that includes a decimal—such as 3.5 mph—press two numbered buttons in succession. For example, to select a speed setting of 3.5 mph, press the 3 button and then immediately press the 5 button.

To stop the walking belt, press the Stop button. To restart the walking belt, press the Start button.

4. Change the incline of the treadmill as desired.

To change the incline of the treadmill, press the Incline increase and decrease buttons or one of the numbered 1 Step Incline/Decline buttons.

Each time you press one of the buttons, the incline will gradually change until it reaches the selected incline setting.

Note: The first time you adjust the incline, you must first calibrate the incline system (see step 4 on page 30).

5. Monitor your progress.

The console offers several display modes. The display mode that you select will determine which workout information is shown. To select the desired display mode, simply flick or slide the screen. You can also view additional information by touching the red boxes on the screen.

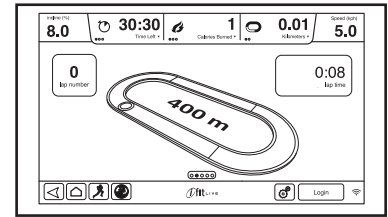

As you walk or run on the treadmill, the screen can show the following workout information:

- The incline level of the treadmill
- The time elapsed
- The time left (Note: The manual mode does not have a time left countdown.)
- The approximate number of calories you have burned
- The approximate number of calories you are burning per hour
- The distance that you have walked or run
- The number of vertical feet you have climbed
- The speed of the walking belt
- A track representing 1/4 mile (400 m)
- Your pace in minutes per mile
- Your current lap number
- Your heart rate (see step 6)

If desired, adjust the volume by pressing the Vol increase and decrease buttons on the console.

To pause the workout, touch one of the menu buttons or press the Stop button on the console. To continue the workout, touch the Resume button or the Start button. To end the workout session, touch the End Workout button.

6. Measure your heart rate if desired.

Note: If you use the handgrip heart rate monitor and the chest heart rate monitor at the same time, the console will not display your heart rate accurately. For information about the chest heart rate monitor, see page 17.

Before using the handgrip heart rate monitor, remove the sheets of plastic from the metal contacts. In addition, make sure that your hands are clean.

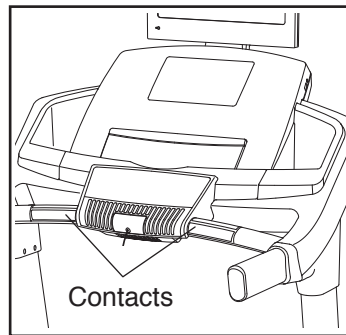

To measure your heart rate, **stand on the foot rails** and hold the contacts with your palms for approximately ten seconds; **avoid moving your hands**. When your pulse is detected, your heart rate will be shown. **For the most accurate heart rate reading, continue to hold the contacts for about 15 seconds.**

7. Turn on the fan if desired.

The fan features multiple speed settings and an auto mode. When the auto mode is selected, the speed of the fan will automatically increase and decrease as the speed of the walking belt increases and decreases.

Press the Manual fan button repeatedly to select a fan speed or to turn off the fan. Press the Auto fan button to select the auto mode or to turn off the fan.



8. When you are finished exercising, remove the key from the console.

Step onto the walking platform and touch the home button or the back button on the screen or press the Stop button on the console. A workout summary will appear on the screen. After you view the workout summary, touch the Finish button to return to the main menu. You may also be able to either save or publish your results using one of the options on the screen. Then, remove the key from the console and put it in a secure place.

When you are finished using the treadmill, press the power switch into the off position and unplug the power cord. **IMPORTANT: If you do not do this, the treadmill's electrical components may wear prematurely.**

HOW TO USE AN ONBOARD WORKOUT

1. Insert the key into the console.

See HOW TO TURN ON THE POWER on page 22.

2. Select an onboard workout.

To select an onboard workout, press the Calorie button, the Intensity button, the Speed button, or the Incline button on the console. Note: You can also touch the runner icon on the screen to select the Workouts menu.

Then, select the desired workout. The screen will show the name, duration, and distance of the workout. The screen will also show the approximate number of calories you will burn during the workout and a profile of the incline settings of the workout.

3. Start the workout.

Touch the Start Workout button to start the workout. A moment after you touch the button, the walking belt will begin to move. Hold the handrails and begin walking.

Each workout is divided into several segments. One speed setting and one incline setting are programmed for each segment. Note: The same speed setting and/or incline setting may be programmed for consecutive segments.

During the workout, the profile will show your progress. To view the profile, flick or slide the screen. The vertical colored line will indicate the current segment of the workout. The bottom profile represents the incline setting of the current segment. The top profile represents the speed setting of the current segment.

At the end of the first segment of the workout, the treadmill will automatically adjust to the speed and/or incline settings for the next segment.

The workout will continue in this way until the last segment ends. The walking belt will then slow to a stop and a workout summary will appear on the screen. After you view the workout summary, touch the Finish button to return to the main menu. You may also be able to either save or publish your results using one of the options on the screen.

If the speed and/or incline settings are too high or too low at any time during the workout, you can override the settings by pressing the Speed or Incline buttons. **If you press a Speed button**, you can then manually control the speed (see step 3 on page 24). **If you press an Incline button**, you can then manually control the incline (see step 4 on page 24). **To return to the programmed speed and/or incline settings of the workout**, first, view the profile. Then, touch the Resume Program button.

To pause the workout, touch either the back button or the home button in the lower-left corner of the screen, or press the Stop button on the console. To continue the workout, touch the Resume button or press the Start button on the console. To end the workout, touch the End Workout button.

Note: The calorie goal is an estimate of the number of calories that you will burn during the workout. The actual number of calories that you burn will depend on various factors such as your weight. In addition, if you manually change the speed or incline of the treadmill during the workout, the number of calories you burn will be affected.

4. Monitor your progress.

See step 5 on page 24. The screen can also show a profile of the speed and incline settings of the workout.

5. Measure your heart rate if desired.

See step 6 on page 25.

6. Turn on the fan if desired.

See step 7 on page 25.

7. When you are finished exercising, remove the key from the console.

See step 8 on page 25.

HOW TO USE A SET-A-GOAL WORKOUT

1. Insert the key into the console.

See HOW TO TURN ON THE POWER on page 22.

2. Select the main menu.

See step 2 on page 24.

3. Select a set-a-goal workout.

To select a set-a-goal workout, touch the Set A Goal button on the screen or press the Set a Goal button on the console.

To set a calorie, time, distance, or pace goal, touch the Calories, Time, Distance, or Pace button.

Then, touch the increase and decrease buttons on the screen to select a calorie, time, distance, or pace goal and to select the speed and incline for the workout. The screen will show the duration and distance of the workout, and the approximate number of calories you will burn during the workout.

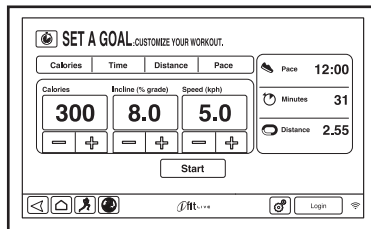

4. Start the workout.

Touch the Start button to start the workout. A moment after you touch the button, the walking belt will begin to move. Hold the handrails and begin walking.

The workout will function in the same way as the manual mode (see pages 24 and 25).

The workout will continue until you reach the goal that you set. The walking belt will then slow to a stop, and a workout summary will appear on the screen. After you view the workout summary, touch the Finish button to return to the main menu. You may also be able to either save or publish your results using one of the options on the screen.

Note: The calorie goal is an estimate of the number of calories that you will burn during the workout. The actual number of calories that you burn will depend on various factors such as your weight.

5. Monitor your progress.

See step 5 on page 24.

6. Measure your heart rate if desired.

See step 6 on page 25.

7. Turn on the fan if desired.

See step 7 on page 25.

8. When you are finished exercising, remove the key from the console.

See step 8 on page 25.

HOW TO USE AN iFIT LIVE WORKOUT

Note: To use an iFit Live workout, you must have access to a wireless network (see HOW TO USE THE WIRELESS NETWORK MODE on page 31). An iFit Live account is also required.

1. Insert the key into the console.

See HOW TO TURN ON THE POWER on page 22.

2. Select the main menu.

See step 2 on page 24.

3. Log in to your iFit Live account.

If you have not already done so, touch the Login button to log in to your iFit Live account. The screen will ask for your iFit.com username and password. Enter them and touch the Submit button. Touch the Cancel button to exit the login screen.

4. Select an iFit Live workout.

To download an iFit Live workout in your schedule, touch the Map, Train, Video, or Lose Weight button

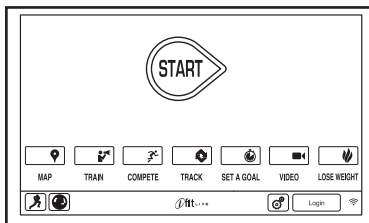

to download the next workout of that type in your schedule. Note: You may be able to access demo workouts through these options, even if you do not log in to an iFit Live account.

To compete in a race that you have previously scheduled, touch the Compete button. To view your Workout History, touch the Track button. To use a set-a-goal workout, touch the Set A Goal button (see page 27). Note: You can also press one of the iFit Live buttons on the console.

To switch users within the account, touch the user button near the lower right corner of the screen.

Before some workouts will download, you must add them to your schedule on iFit.com.

For more information about the iFit Live workouts, please see www.iFit.com.

When you select an iFit Live workout, the screen will show the name, duration, and distance of the workout. The screen will also show the approximate number of calories you will burn during the workout. If you select a competition workout, the display will count down to the beginning of the race.

5. Start the workout.

See step 3 on page 26.

During some workouts, the voice of a personal trainer will guide you through your workout.

6. Monitor your progress.

See step 5 on page 24. The screen may also show a map of the trail you are walking or running.

During a competition workout, the screen will show the speeds of the runners and the distances they have run. The screen will also show the numbers of seconds that the other runners are ahead of you or behind you.

7. Measure your heart rate if desired.

See step 6 on page 25.

8. Turn on the fan if desired.

See step 7 on page 25.

9. When you are finished exercising, remove the key from the console.

See step 8 on page 25.

For more information about the iFit Live mode, go to www.iFit.com.

HOW TO USE THE EQUIPMENT SETTINGS MODE

The console features an equipment settings mode that allows you to select a language, the unit of measurement, and a timezone; to turn on and turn off the display demo mode; and to enable or disable the key and/or a passcode.

1. Select the settings main menu.

Insert the key into the console (see HOW TO TURN ON THE POWER on page 22). Next, select the main menu (see step 2 on page 24). Then, touch the gears button near the lower right corner of the screen to select the settings main menu.

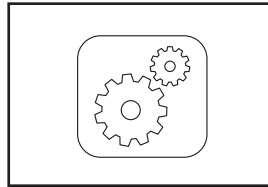

2. Select the equipment settings mode.

In the settings main menu, touch the Equipment Settings button.

3. Select a language.

To select a language, touch the Language button and select the desired language. Then, touch the back button on the screen to return to the equipment settings mode. Note: This feature may not be enabled.

4. Select the unit of measurement.

Touch the US/Metric button to view the selected unit of measurement. Change the unit of measurement, if desired. Then, touch the back button on the screen.

5. Select a timezone.

Touch the Timezone button. Select your local timezone to have the console sync to your local time. Then, touch the back button.

6. Turn on or turn off the display demo mode.

The console features a display demo mode, designed to be used if the treadmill is displayed

in a store. While the demo mode is turned on, the console will function normally when you plug in the power cord, press the power switch into the reset position, and insert the key into the console. However, when you remove the key, the screen will show a demo presentation.

To turn on or turn off the display demo mode, first touch the Demo Mode button. Next, touch the On checkbox or the Off checkbox. Then, touch the back button on the screen.

7. Enable or disable the key.

Note: This feature may not be enabled on your treadmill.

You can disable the key so that the treadmill does not require the use of the key if desired. Touch the Safety Key button. To disable the key, touch the Disable checkbox. **CAUTION: Read the safety warning on the screen before disabling the key.** To enable the key again, touch the Enable checkbox.

8. Enable or disable a passcode.

The console features a child safety passcode, designed to prevent unauthorized users from using the treadmill.

Touch the Passcode button. To enable a passcode, touch the Enable checkbox. Then, enter a 4-digit passcode of your choice. Touch Save to use this passcode. Touch Cancel to return to the equipment settings mode and not use a passcode. To disable the passcode, touch the Disable checkbox.

Note: If a passcode is enabled, the console will regularly ask for you to enter the passcode. The console will remain locked until the correct passcode is entered. **IMPORTANT: If you forget your passcode, enter the following master passcode to unlock the console: 1985.**

9. Exit the equipment settings mode.

To exit the equipment settings mode, touch the back button on the screen.

HOW TO USE THE MAINTENANCE MODE

The console features a maintenance mode that allows you to update the console firmware, calibrate the incline of the treadmill, view machine information, and view a button's keycode.

1. Select the settings main menu.

See step 1 on page 29.

2. Select the maintenance mode.

In the settings main menu, touch the Maintenance button to enter the maintenance mode.

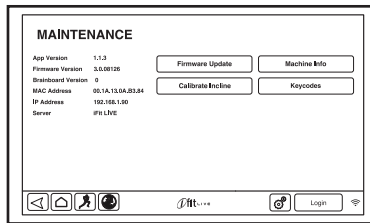

The maintenance mode main screen will show information about the model and version of the treadmill.

3. Update the console firmware.

For the best results, regularly check for firmware updates.

Touch the Firmware Update button to check for firmware updates using your wireless network. The update will begin automatically.

The screen will show the progress of the update. When the update is complete, the treadmill will turn off and then turn back on. If it does not, press the power switch into the off position. Wait for several seconds, and then press the power switch into the reset position. Note: It may take a few minutes for the console to be ready for use.

To avoid damaging the treadmill, do not turn off the power or remove the key while the firmware is being updated.

Note: Occasionally, a firmware update may cause your console to function slightly differently. These updates are always designed to improve your exercise experience.

4. Calibrate the incline system of the treadmill.

Touch the Calibrate Incline button. Then, touch the Begin button to calibrate the incline system. The treadmill will automatically rise to the maximum incline level, lower to the minimum incline level, and then return to the starting position. This will calibrate the incline system. Press the Cancel button to return to the maintenance mode. When the incline system is calibrated, touch the Finish button.

IMPORTANT: Keep pets, feet, and other objects away from the treadmill while the incline system is calibrating. In an emergency, pull the key from the console to stop the incline calibration.

5. View machine information.

Touch the Machine Info button to view information about your treadmill. After you view the information, touch the back button on the screen.

6. Find keycodes.

The Keycodes button is intended to be used by service technicians to identify whether a certain button is working correctly.

7. Exit the maintenance mode.

To exit the maintenance mode, press the back button on the console.

HOW TO USE THE WIRELESS NETWORK MODE

The console features a wireless network mode that allows you to set up a wireless network connection.

1. Select the settings main menu.

See step 1 on page 29.

2. Select the wireless network mode.

In the settings main menu, touch the Wireless Network button to enter the wireless network mode.

3. Enable Wi-Fi.

Make sure that the Wi-Fi checkbox is marked with a green checkmark. If it is not, touch the Wi-Fi menu option once and wait for a few seconds. The console will search for available wireless networks.

4. Set up and manage a wireless network connection.

When Wi-Fi is enabled, the screen will show a list of available networks. Note: It may take several seconds for the list of wireless networks to appear.

Make sure that the checkbox on the Network notification menu option is marked with a green checkmark to have the console notify you when a wireless network is within range and available.

Note: You must have your own wireless network and an 802.11b/n router with SSID broadcast enabled (hidden networks are not supported).

When a list of networks appears, touch the desired network. Note: You will need to know your network name (SSID). If your network has a password, you will also need to know the password.

An information box will ask if you want to connect to the wireless network. Touch the Connect button to connect to the network or touch the Cancel button to return to the list of networks. If the network has a password, touch the password entry box. A keyboard will appear on the screen. To view the password as you type it, touch the Show Password checkbox.

To use the keyboard, see HOW TO USE THE TOUCH SCREEN on page 22.

When the console is connected to your wireless network, the WiFi menu option at the top of the screen will display the word CONNECTED. Then, press the back button on the console to return to the wireless network mode.

To disconnect from a wireless network, select the wireless network and then touch the Forget button.

If you are having problems connecting to an encrypted network, make sure that your password is correct. Note: Passwords are case-sensitive.

Note: The iFit Live mode supports unsecured and secured (WEP, WPA, and WPA2) encryption. A broadband connection is recommended; performance depends on connection speed.

Note: If you have questions after following these instructions, go to support.iFit.com for assistance.

5. Exit the wireless network mode.

To exit the wireless network mode, press the back button on the console.

HOW TO USE THE STEREO SOUND SYSTEM

To play music or audio books through the console's speakers, you must connect your MP3 player, CD player, or other personal audio player to the console.

Plug one end of your audio wire into the audio jack on the side of the console. Then, plug the other end into a jack on your MP3 player, CD player, or other personal audio player. **Make sure that your audio wire is fully plugged in.**

Next, press the play button on your MP3 player, CD player, or other personal audio player. Then, adjust the volume level on your personal audio player or press the volume increase and decrease buttons on the console.

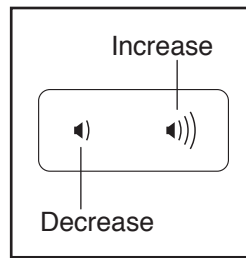

If you are using a personal CD player and the CD skips, set the CD player on the floor or another flat surface instead of on the console.

HOW TO USE THE INTERNET BROWSER

Note: To use the browser, you must have access to a wireless network including an 802.11b/n router with SSID broadcast enabled (hidden networks are not supported).

To open the browser, touch the globe button near the lower left corner of the screen. Then, select a website.

To return to the previous web page, press the back button on the console or touch the Browser Back button on the screen. To exit the browser, press the home button on the console or touch the Return button on the screen.

To use the keyboard, see HOW TO USE THE TOUCH SCREEN on page 22.

To enter a different web address in the URL bar, first, slide your finger down the screen to view the URL bar, if necessary. Then, touch the URL bar, use the keyboard to enter the address, and touch the Go button.

Note: While you are using the browser, the speed, incline, fan, and volume buttons will still function, but the workout buttons will not function.

Note: If you have questions after following these instructions, go to support.iFit.com for assistance.

HOW TO OPERATE THE 15" DIGITAL TV

The 15" digital TV can be controlled with the control buttons found on your exercise equipment's console or with the remote control (see page 34).

1. Turn the 15" digital TV on.

To turn on the 15" digital TV, press the TV power button, which is the top button on the console TV control.

2. Select a TV input source.

To switch between cable or antenna input and another audio/visual input device such as a VCR, DVD player, or Blu-ray player, press the Input button repeatedly. Select TV for cable or antenna input, AV for a device connected to the TV with an AV cable, or HDMI for a device connected with an HDMI cable.

3. Select the desired channel.

To select the desired cable channel, press the CH increase and decrease buttons or the Key Pad button. Note: If you press the Key Pad button, a ten-number button pad will appear on your console's touch screen. Touch the numbers for the desired cable channel.

When the buttons are pressed, a graphic will appear on-screen to show which channel is selected.

Note: The 15" digital TV can identify and store in memory all valid cable channels in your area (see HOW TO ADJUST THE TELEVISION SETTINGS on page 35). The CH increase and decrease buttons will select only channels that are stored in memory. If a satellite TV box, VCR, DVD player, or Blu-ray player is connected and used as the input source, the channel must be changed on the satellite TV box, VCR, DVD player, or Blu-ray player.

4. Adjust the volume as desired.

Note: The Vol increase and decrease buttons do not affect the volume of the 15" digital TV. To adjust the TV volume, either use the on-screen control (see HOW TO USE THE ENTERTAINMENT MODE at the right) or use the remote control (see HOW

TO USE THE REMOTE CONTROL on page 34). When the volume is adjusted, a graphic will appear on-screen to show which volume setting is selected.

5. Mute the TV if desired.

Press the Mute button to turn off the TV's audio output. Press the button again or adjust the volume to turn on the TV's audio output.

6. Use closed captioning if desired.

If the TV show or movie you are watching has closed captioning, you can use this feature to display an on-screen text version of the audio output. To view closed captioning on the 15" digital TV, press the CC button repeatedly (see step 6 on page 36 to adjust closed captioning settings).

7. When you are done using the 15" digital TV, turn the TV off.

To turn off the 15" digital TV, press the TV power button.

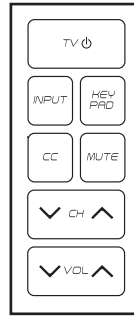

HOW TO USE THE ENTERTAINMENT MODE

The console features an entertainment mode that allows you to access an on-screen remote control.

1. Access the settings main menu.

See step 1 on page 29.

2. Select the entertainment mode.

In the settings main menu, touch the Entertainment button to enter the entertainment mode.

3. Select custom settings.

Touch the Custom Settings button to access an on-screen remote control. Note: This on-screen control functions similarly to the included remote control (see page 34 to learn how to use the remote control).

4. Exit the entertainment mode.

To exit the entertainment mode, touch the back button on the screen.

HOW TO USE THE REMOTE CONTROL

The first time you use the remote control, insert batteries (see HOW TO REPLACE THE BATTERIES IN THE REMOTE CONTROL at the right).

Next, stand on the treadmill and hold the remote control near the television. Point the remote control directly at the television.

Press the Power button (⏻). After a few moments, the television will turn on or turn off.

Press the volume (Vol) increase or decrease button to adjust the TV volume.

Press the Mute button to turn on or turn off the sound.

Press the numbered channel buttons and the dash button (–) or the Channel (CH) increase or decrease button to select a channel.

Press the return button (↶) to view the previous channel.

Press the Menu button to view the main menu or to view a previous menu. See pages 35 and 36 for information about the menu.

Press the arrow keys to navigate in the menu. Press the OK/Enter button to make a selection in the menu.

Press the Exit button to exit any menu.

Press the List button to view a list of channels. If you have labeled any channels, the menu will also show the channel label. See page 35 for information about labeling channels.

Press the EPG button to view the electronic program guide. Note: The electronic program guide is only available when viewing ATSC digital television.

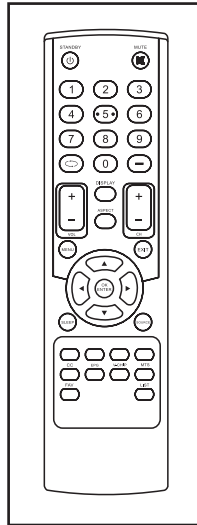

Press the Display button to view information about the current program and the broadcast or cable signal.

Press the CC button repeatedly to turn on or turn off closed captioning. See step 6 on page 36 to adjust closed captioning settings.

Press the Source button repeatedly to select the input source. Select TV for cable or antenna input, AV for a device connected to the TV with an AV cable, or HDMI for a device connected with an HDMI cable.

Press the MTS button repeatedly to select English or Spanish as the audio setting language.

Press the Aspect button repeatedly to select normal, wide, cinema, or zoom image as the display format.

Press the V-Chip button to adjust parental control settings.

Press the Fav button to select the Favorite List of channels. See step 4 on page 35 to create a favorite channels list.

HOW TO REPLACE THE BATTERIES IN THE REMOTE CONTROL

To replace the batteries, first locate the battery cover on the back of the remote control. Push down on the clip on the battery cover and pull off the battery cover.

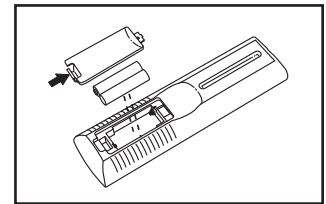

Next, remove the old batteries from the remote control, and insert two new AAA batteries. **Make sure to insert the batteries as shown in the drawing.** Then, press the battery cover onto the remote control.

HOW TO ADJUST THE TELEVISION SETTINGS

The 15" digital TV has a menu that allows you to adjust and personalize television settings.

Press the Menu button on the remote control or the on-screen control (see HOW TO USE THE ENTERTAINMENT MODE on page 33) to enter the main menu or to return to a previous menu. Press the Exit button to exit the menu. Use the arrow buttons to navigate right and left or up and down in a menu. Press the OK/Enter button to make a selection.

1. Press the Menu button to enter the main menu.

To select one of the icons in the menu, press the left and right arrow buttons on your remote

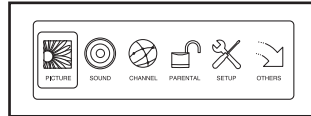

control until the desired icon is highlighted. Select Picture to adjust the image settings. Select Sound to adjust the audio settings. Select Channel to adjust the channel settings. Select Parental to adjust the parental control settings. Select Setup to adjust basic television settings. Select Others to adjust advanced television settings. To return to the main menu, press the Menu button.

2. Adjust the image settings.

The Picture menu offers numerous features for adjusting the TV display. Use the arrow buttons to navigate through the various settings and personalize the image settings.

3. Adjust the audio settings.

The Audio menu offers numerous features for adjusting the TV audio output. Use the arrow buttons to navigate through the various settings and personalize the audio settings.

4. Adjust the channel settings.

The Channel menu allows you to save channels in the TV memory and select settings for channels. Note: You can only access this menu if TV is selected as the input source.

First, scroll to the bottom of the Channel menu and highlight Auto Channel Search. Press the Enter button to start the auto scan. The television will begin scanning all of the channels available in your area. When no signal is detected on a channel, the channel will be skipped. When a signal is detected, the channel will be saved into memory and the next channel will be selected. This process will continue until the highest channel number is reached. The television will renumber the channels in the order in which it locates them. **Do not remove the key while the television is scanning channels.** Note: If a television channel disappears, scan for channels again.

Next, select Channel Settings to view a list of channels saved in the TV memory. Select a checkbox in the Skip column and press Enter to have the TV not use this channel. Select a checkbox in the Favorite column to add the channel to your favorite channels list. Select the text in the Label column to change the channel's label. Edit the label using the arrow buttons.

Select Channel List to view a list of channels saved in the TV memory. Highlight a channel and press Enter to select the channel.

Select Favorite List to view a list of your favorite channels. Highlight a channel and press Enter to select the channel. Note: You must first select favorite channels to create the Favorite List.

5. Adjust the parental control settings.

The Parental menu allows you to block or allow various settings on the 15" digital TV.

First, enter the Lock Parental Code password, which is a 4-digit PIN. Note: The default password is 0000. Once the password has been entered, the Parental menu will be unlocked.

Select V-CHIP to control which television and movie ratings are blocked or allowed. Note: The lock icon will indicate whether a rating has been blocked or allowed.

Select Change Password to change the Lock Parental Code password. Enter the old password once, then enter the new password twice to confirm. You will now have to enter the new password to enter the Parental menu. **Note: If you forget your password, enter the following master password to access locked menus: 1470.**

Select Keypad Lock to lock the keypad.

Select Source Lock to lock a specific audio/video input source, such as TV, AV, or HDMI.

6. Set up the basic television settings.

The Setup menu allows you to adjust the closed caption settings, the language used in the menus, and the clock settings.

To enter the closed caption submenu, highlight Closed Caption and press the Enter button. In the closed caption submenu, adjust the caption display, caption type, and the digital preset and style.

Select Menu Language to change the language used in the menus.

Select Clock to adjust the TV clock's time zone, auto setting, time setting, day of the week setting, and daylight saving time setting.

7. Adjust the advanced television settings.

The Others menu offers several advanced television settings. You can also restore the original television settings.

Select the Blue Back to have the TV screen display blue when no signal is detected.

Select No Signal Power Off to have the TV shut off if no signal is detected for 10 minutes.

Select No Operation Power Off to have the TV shut off if no buttons are pressed on the remote control, on-screen control, or console TV control for 3 hours.

When you highlight All Reset, a warning will appear in the display. Make sure to read the warning, then press Enter to restore the original television settings. Note: All of your favorite channels, labels, and personal adjustments will be erased.

8. Exit the menu.

When you have finished adjusting the settings, press the Exit button.

HOW TO FOLD AND MOVE THE TREADMILL

HOW TO FOLD THE TREADMILL

To avoid damaging the treadmill, adjust the incline to zero percent before you fold the treadmill. Then, remove the key and unplug the power cord. **CAUTION:** You must be able to safely lift 45 lbs. (20 kg) to raise, lower, or move the treadmill.

1. Hold the metal frame firmly in the location shown by the arrow below. **CAUTION: Do not hold the frame by the plastic foot rails. Bend your legs and keep your back straight.**

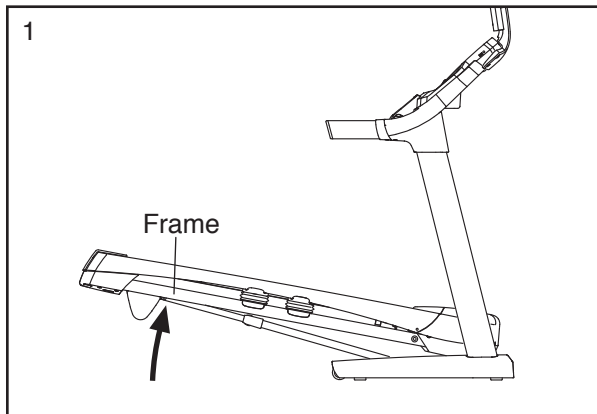

2. Raise the frame until the latch knob locks in the storage position. **CAUTION: Make sure that the latch knob locks.**

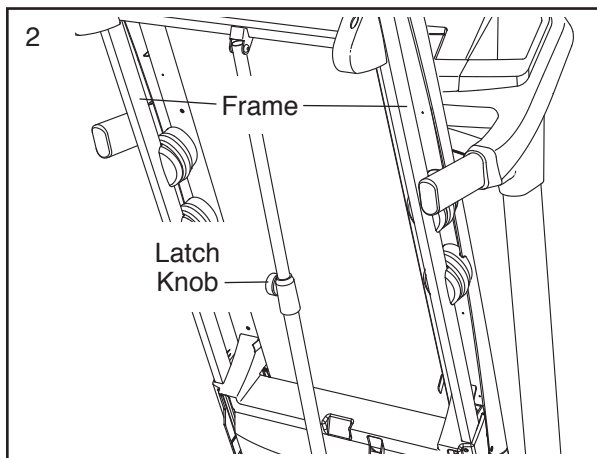

To protect the floor or carpet, place a mat under the treadmill. Keep the treadmill out of direct sunlight. Do not leave the treadmill in the storage position in temperatures above 85° F (30° C).

HOW TO MOVE THE TREADMILL

Before moving the treadmill, fold it as described at the left. **CAUTION: Make sure that the latch knob is locked in the storage position. Moving the treadmill may require two people.**

1. Hold the frame and one of the handrails, and place one foot against a wheel.

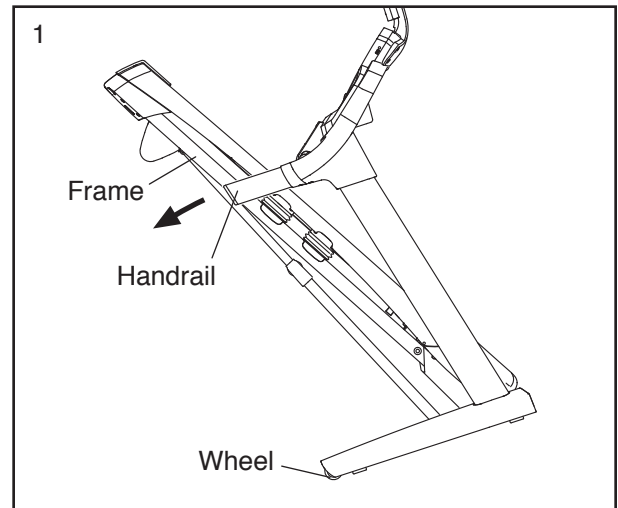

2. Pull back on the handrail until the treadmill will roll on the wheels, and carefully move it to the desired location. **CAUTION: Do not move the treadmill without tipping it back, do not pull on the frame, and do not move the treadmill over an uneven surface.**
3. Place one foot against a wheel, and carefully lower the treadmill.

HOW TO LOWER THE TREADMILL FOR USE

1. **See drawing 2.** Hold the upper end of the treadmill frame with your right hand. Then, pull the latch knob to the left. **IMPORTANT: Do not turn the latch knob.** If necessary, push the frame forward slightly. Pivot the frame downward a few inches, and release the latch knob.
2. **See drawing 1 at the left.** Hold the metal frame firmly with both hands, and lower it to the floor. **CAUTION: Do not hold the frame by the plastic foot rails, and do not drop the frame. Bend your legs and keep your back straight.**

TROUBLESHOOTING

Most treadmill problems can be solved by following the simple steps below. Find the symptom that applies, and follow the steps listed. If further assistance is needed, see the front cover of this manual.

SYMPTOM: The power does not turn on

- Make sure that the power cord is plugged into a surge suppressor, and that the surge suppressor is plugged into a properly grounded outlet (see page 18). Use only a surge suppressor that meets all of the specifications described on page 18.
IMPORTANT: The treadmill is not compatible with GFCI-equipped outlets and may not be compatible with AFCI-equipped outlets.
- After the power cord has been plugged in, make sure that the key is inserted into the console.
- Check the power switch located on the treadmill frame near the power cord. If the switch protrudes as shown, the switch has tripped. To reset the power switch, wait for five minutes and then press the switch back in.

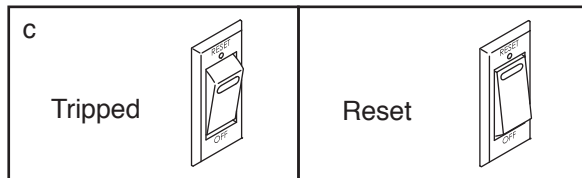

SYMPTOM: The power turns off during use

- Check the power switch (see the drawing above). If the switch has tripped, wait for five minutes and then press the switch back in.
- Make sure that the power cord is plugged in. If the power cord is plugged in, unplug it, wait for five minutes, and then plug it back in.

- Remove the key from the console, and then reinsert it.
- If the treadmill still will not run, please see the front cover of this manual.

SYMPTOM: The console displays remain lit when you remove the key from the console

- The console features a display demo mode, designed to be used if the treadmill is displayed in a store. If the screen shows a preset presentation when you remove the key, the demo mode is turned on. To turn off the demo mode, hold down the Stop button for a few seconds. If the demo mode is still on, see step 6 on page 29 to turn off the demo mode.

SYMPTOM: The displays of the console do not function properly

- Remove the key from the console and **UNPLUG THE POWER CORD**. Remove the three #8 x 1/2" Screws (1) and the two #8 x 3/4" Screws (2). Carefully pivot the Motor Hood (65) off.

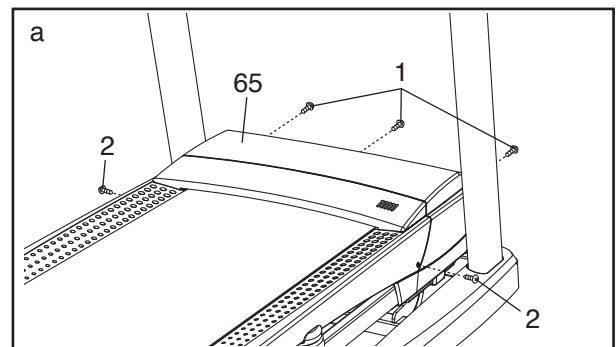

Locate the Reed Switch (52) and the Magnet (50) on the left side of the Pulley (49). Turn the Pulley until the Magnet is aligned with the Reed Switch. **Make sure that the gap between the Magnet and the Reed Switch is about 1/8 in. (3 mm).** If necessary, loosen the #8 x 3/4" Tek Screw (14), move the Reed Switch slightly, and then retighten the Screw. Reattach the Motor Hood (not shown) and run the treadmill for a few minutes to check for a correct speed reading.

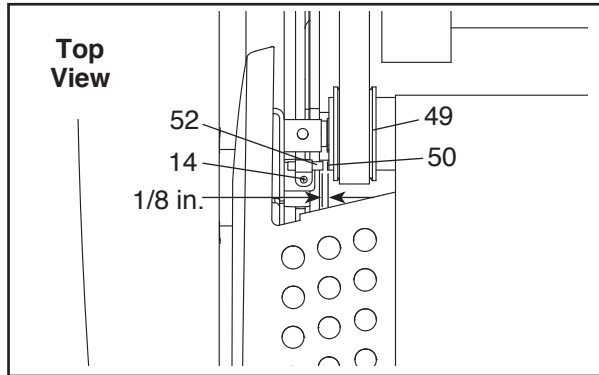

SYMPTOM: The incline of the treadmill does not change correctly

- a. Calibrate the incline system (see step 4 on page 30).

SYMPTOM: The walking belt slows when walked on

- a. Use only a surge suppressor that meets all of the specifications described on page 18.
- b. If the walking belt is overtightened, treadmill performance may decrease and the walking belt may become damaged. Remove the key and **UNPLUG THE POWER CORD.** Using the hex key, turn both idler roller screws counterclockwise, 1/4 of a turn.

When the walking belt is properly tightened, you should be able to lift each edge of the walking belt 2 to 3 in. (5 to 7 cm) off the walking platform. Be careful to keep the walking belt centered. Then, plug in the power cord, insert the key, and run the treadmill for a few minutes. Repeat until the walking belt is properly tightened.

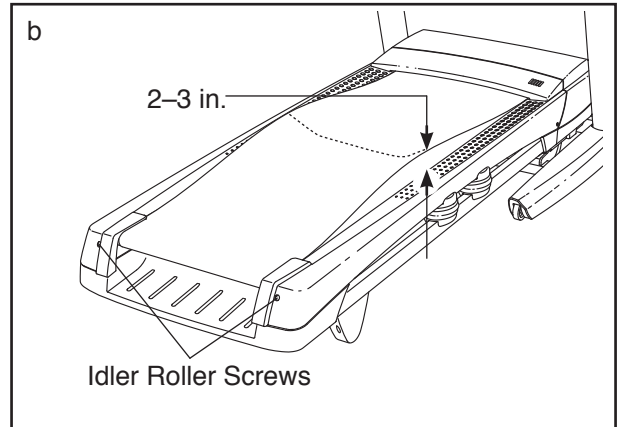

- c. Your treadmill features a walking belt coated with high-performance lubricant. **IMPORTANT: Never apply silicone spray or other substances to the walking belt or the walking platform unless instructed to do so by an authorized service representative. Such substances may deteriorate the walking belt and cause excessive wear.** If you suspect that the walking belt needs more lubricant, see the front cover of this manual.
- d. If the walking belt still slows when walked on, see the front cover of this manual.

SYMPTOM: The walking belt is off-center or slips when walked on

- a. **If the walking belt is off-center**, first remove the key and **UNPLUG THE POWER CORD**. **If the walking belt has shifted to the left**, use the hex key to turn the left idler roller screw clockwise 1/2 of a turn; **if the walking belt has shifted to the right**, turn the left idler roller screw counterclockwise 1/2 of a turn. Be careful not to overtighten the walking belt. Then, plug in the power cord, insert the key, and run the treadmill for a few minutes. Repeat until the walking belt is centered.

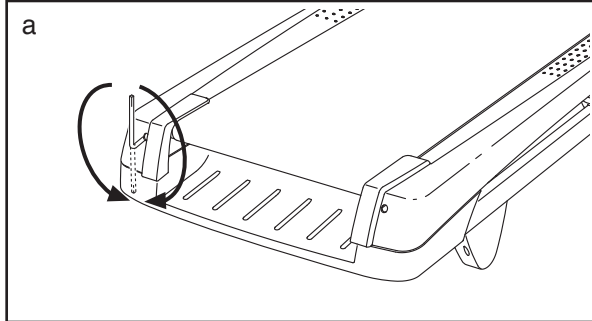

- b. **If the walking belt slips when walked on**, first remove the key and **UNPLUG THE POWER CORD**. Using the hex key, turn both idler roller screws clockwise, 1/4 of a turn. When the walking belt is correctly tightened, you should be able to lift each edge of the walking belt 2 to 3 in. (5 to 7 cm) off the walking platform. Be careful to keep the walking belt centered. Then, plug in the power cord, insert the key, and carefully walk on the treadmill for a few minutes. Repeat until the walking belt is properly tightened.

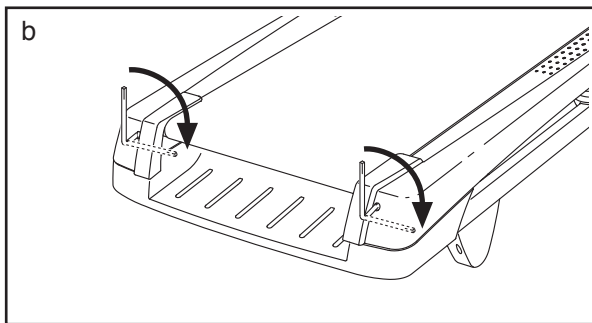

SYMPTOM: The iFit Live mode does not function correctly

- a. If the iFit Live mode is not functioning correctly, make sure that the treadmill has the most current firmware available (see step 3 on page 30).

SYMPTOM: The treadmill will not connect to the wireless network

- a. Make sure that the wireless settings on your console are correct (see step 4 on page 31).
- b. Make sure that the settings for your wireless network are correct.
- c. If you still have questions, see the front cover of this manual.

SYMPTOM: The television is not receiving a signal

- a. Make sure that the correct TV or AV source is selected. See step 2 on page 33 to select a television source.
- b. Make sure that the antenna cable, CATV cable, AV cable, or HDMI cable is connected securely to the treadmill or the 15" digital TV. See page 19 to connect a CATV cable to the treadmill or page 20 to connect an AV cable or HDMI cable to the TV.
- c. Scan for broadcast or cable signals. See step 4 on page 35 to scan for signals.
- d. Due to an FCC requirement, analog signals are no longer broadcast over the air in the United States as of June 12, 2009. If you wish to view television signals through an antenna, you must have an antenna capable of receiving digital signals. Cable television has not been affected.

SYMPTOM: The volume cannot be turned up

- a. If there is no sound coming from the television, make sure that the television audio is not muted.
- b. If there is no sound coming from the television, make sure that the audio wire is not plugged into the audio jack on the console.

SYMPTOM: The television needs to be cleaned

- a. **UNPLUG THE POWER CORD.** To clean the television, wipe the television and screen using a soft cloth with a small amount of soft detergent. Do not use a polishing cloth, solvent, or any type of propellant or chemical detergent such as alcohol or benzene.

SYMPTOM: Television reception is poor

- a. Make sure that the television settings are set correctly. See HOW TO ADJUST THE TELEVISION SETTINGS on page 35.
- b. For the television to operate properly, good reception is necessary. If you are using an antenna, make sure that it is properly connected and adjusted for optimal reception. (See HOW TO CONNECT AN ANTENNA on page 19.)
- c. Check for the problems listed at the right and follow the applicable instructions.

- Ignition (black spots or horizontal streaks that appear or a picture that flutters or drifts)—Usually this is caused by interference from automobile ignition systems, neon lamps, electric drifts, or other electric appliances. Try changing the position of the treadmill or other electric appliances to correct the problem.
- Ghosts—Ghosts are caused by the television signal following two paths—one is the direct path and the other is reflected from tall buildings, hills, or other objects. Change the direction or position of the antenna to improve reception.
- Blue Screen—If the treadmill is located in the fringe area of a television station where the signal is weak, the picture may be of poor quality or a blue screen may appear. If the signal is weak, it may be necessary to install an external antenna to improve the picture.
- Fading—If blocks of the picture are missing, the picture moves around the screen, or the picture disappears, the signal may be weak. Change the direction or position of the antenna to improve reception. Make sure the television settings are set correctly (see HOW TO ADJUST TELEVISION SETTINGS on page 35). Do not use a splitter.

Note: If one of these problems appears when the cable from a CATV company is connected, the problem may be caused by the cable company broadcast.

EXERCISE GUIDELINES

⚠️ WARNING: Before beginning this or any exercise program, consult your physician. This is especially important for persons over age 35 or persons with pre-existing health problems.

The heart rate monitor is not a medical device. Various factors may affect the accuracy of heart rate readings. The heart rate monitor is intended only as an exercise aid in determining heart rate trends in general.

These guidelines will help you to plan your exercise program. For detailed exercise information, obtain a reputable book or consult your physician. Remember, proper nutrition and adequate rest are essential for successful results.

EXERCISE INTENSITY

Whether your goal is to burn fat or to strengthen your cardiovascular system, exercising at the proper intensity is the key to achieving results. You can use your heart rate as a guide to find the proper intensity level. The chart below shows recommended heart rates for fat burning and aerobic exercise.

165	155	145	140	130	125	115	♥♥
145	138	130	125	118	110	103	♥
125	120	115	110	105	95	90	♥
<hr/>							
20	30	40	50	60	70	80	

To find the proper intensity level, find your age at the bottom of the chart (ages are rounded off to the nearest ten years). The three numbers listed above your age define your “training zone.” The lowest number is the heart rate for fat burning, the middle number is the heart rate for maximum fat burning, and the highest number is the heart rate for aerobic exercise.

Burning Fat—To burn fat effectively, you must exercise at a low intensity level for a sustained period of time. During the first few minutes of exercise, your body uses carbohydrate calories for energy. Only after the first few minutes of exercise does your body begin to use stored fat calories for energy. If your goal is to burn fat, adjust the intensity of your exercise until your heart rate is near the lowest number in your training zone. For maximum fat burning, exercise with your heart rate near the middle number in your training zone.

Aerobic Exercise—If your goal is to strengthen your cardiovascular system, you must perform aerobic exercise, which is activity that requires large amounts of oxygen for prolonged periods of time. For aerobic exercise, adjust the intensity of your exercise until your heart rate is near the highest number in your training zone.

WORKOUT GUIDELINES

Warming Up—Start with 5 to 10 minutes of stretching and light exercise. A warm-up increases your body temperature, heart rate, and circulation in preparation for exercise.

Training Zone Exercise—Exercise for 20 to 30 minutes with your heart rate in your training zone. (During the first few weeks of your exercise program, do not keep your heart rate in your training zone for longer than 20 minutes.) Breathe regularly and deeply as you exercise—never hold your breath.

Cooling Down—Finish with 5 to 10 minutes of stretching. Stretching increases the flexibility of your muscles and helps to prevent post-exercise problems.

EXERCISE FREQUENCY

To maintain or improve your condition, complete three workouts each week, with at least one day of rest between workouts. After a few months of regular exercise, you may complete up to five workouts each week, if desired. Remember, the key to success is to make exercise a regular and enjoyable part of your everyday life.

PART LIST

Model No. PFTL20511.0 R0612A

Key No.	Qty.	Description	Key No.	Qty.	Description
1	21	#8 x 1/2" Screw	64	1	Short Hex Key
2	57	#8 x 3/4" Screw	65	1	Motor Hood
3	1	3/8" x 2" Bolt	66	1	Hood Accent
4	2	5/16" x 1 1/4" Bolt	67	2	Incline Frame Spacer
5	4	5/16" x 1" Screw	68	1	Incline Motor Sensor
6	1	3/8" x 1 3/4" Bolt	69	1	Incline Motor
7	4	3/8" x 2 3/4" Screw	70	1	Incline Frame
8	4	3/8" x 1 1/4" Screw	71	2	Frame Spacer
9	2	#10 x 3/4" Screw	72	1	Controller
10	7	#8 x 1/2" Ground Screw	73	1	Controller Plate
11	4	5/16" Star Washer	74	2	Hood Post
12	2	3/8" Nut	75	1	Power Switch
13	4	3/8" Star Washer	76	1	Power Cord
14	17	#8 x 3/4" Tek Screw	77	2	Grommet
15	2	Idler Roller Screw	78	1	Belly Pan
16	1	3/8" x 1 1/2" Bolt	79	1	Left Upright Cover
17	2	3/8" x 1 3/4" Wheel Bolt	80	1	Right Upright Cover
18	2	#8 x 1 3/4" Screw	81	1	Upright Wire
19	9	#8 x 7/16" Screw	82	1	Left Base Cover
20	2	5/16" Motor Screw	83	1	Right Base Cover
21	2	1/2" x 2 1/4" Bolt	84	2	Handrail Cap
22	2	3/8" x 1" Bolt	85	1	Left Handrail Cover
23	4	5/16" x 1 3/4" Shoulder Bolt	86	1	Right Handrail Cover
24	1	1/4" x 1" Screw	87	1	Right Handrail
25	4	#8 x 1" Screw	88	1	Left Handrail
26	2	1/4" Washer	89	1	Left Upright
27	2	1/4" Lock Washer	90	1	Right Upright
28	4	#8 x 3/4" Belly Pan Screw	91	2	Warning Decal
29	1	3/8" x 2" Hex Head Bolt	92	4	Base Pad
30	4	5/16" Platform Flat Washer	93	1	Crossbar
31	2	5/16" Cage Nut	94	1	Base
32	2	1/2" Nut	95	1	Right Wheel Cap
33	6	3/8" Jam Nut	96	1	Left Wheel Cap
34	4	5/16" Nut	97	2	Wheel
35	7	1/4" Star Washer	98	1	Key/Clip
36	4	1/4" x 1/2" Screw	99	2	Cable Tie
37	1	Left Front Isolator Top	100	1	Chest Strap
38	2	Rear Isolator Top	101	1	Sensor
39	4	Isolator	102	1	3/16" x 7/32" Hex Key
40	4	Isolator Bottom	103	1	Console
41	1	Right Front Isolator Top	104	1	Console Frame
42	1	Left Foot Rail	105	1	Ground Wire
43	1	Caution Decal	106	2	Console Clamp
44	1	Walking Platform	107	1	Left Tray
45	1	Walking Belt	108	1	Right Tray
46	2	Belt Guide	109	1	Console Base
47	2	Foot Rail Track	110	1	Power Supply Bracket
48	4	Cable Tie	111	3	Hood Clip
49	1	Drive Roller/Pulley	112	2	#10 x 3/4" Flat Head Screw
50	1	Magnet	113	4	5/16" Flat Washer
51	1	Reed Switch Clip	114	4	#8 x 1/2" Machine Screw
52	1	Reed Switch	115	4	M4 x 12mm Screw
53	1	Storage Latch	116	4	1/4" x 3/4" Screw
54	1	Drive Motor	117	1	Wire Cover
55	1	Motor Belt	118	1	TV Bracket
56	1	Frame	119	1	TV
57	2	Rear Foot	120	1	TV Trim
58	1	Frame Endcap Cover	121	1	TV Remote Control
59	4	Rubber Cushion	122	1	Upright Coaxial Cable
60	1	Right Foot Rail	123	4	Stand-Off
61	1	Idler Roller	124	1	Power Supply
62	1	Frame Endcap	*	-	User's Manual
63	1	Hex Key			

Note: Specifications are subject to change without notice. For information about ordering replacement parts, see the back cover of this manual. *These parts are not illustrated.

EXPLODED DRAWING B

Model No. PFTL20511.0 R0612A

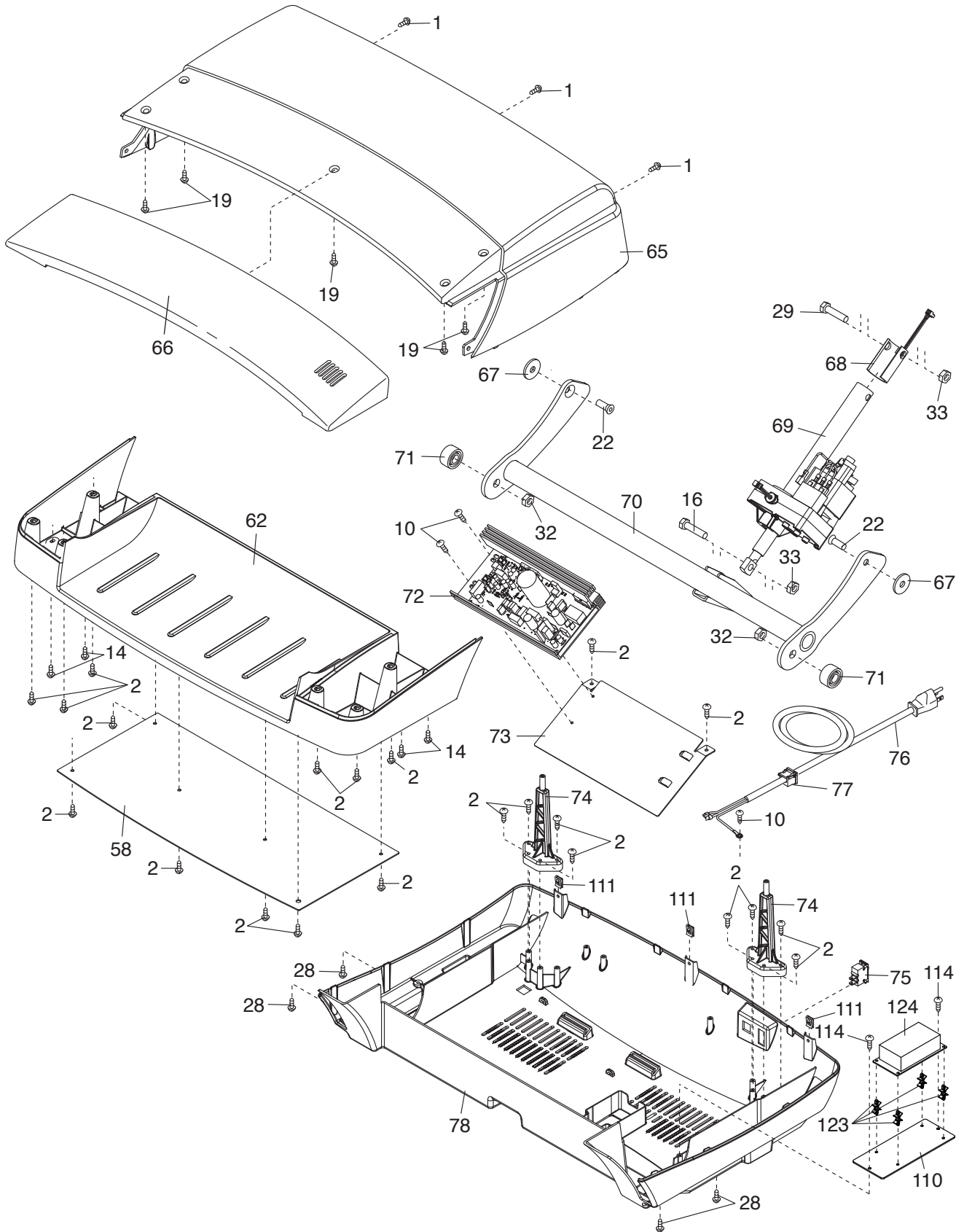

EXPLODED DRAWING C

Model No. PFTL20511.0 R0612A

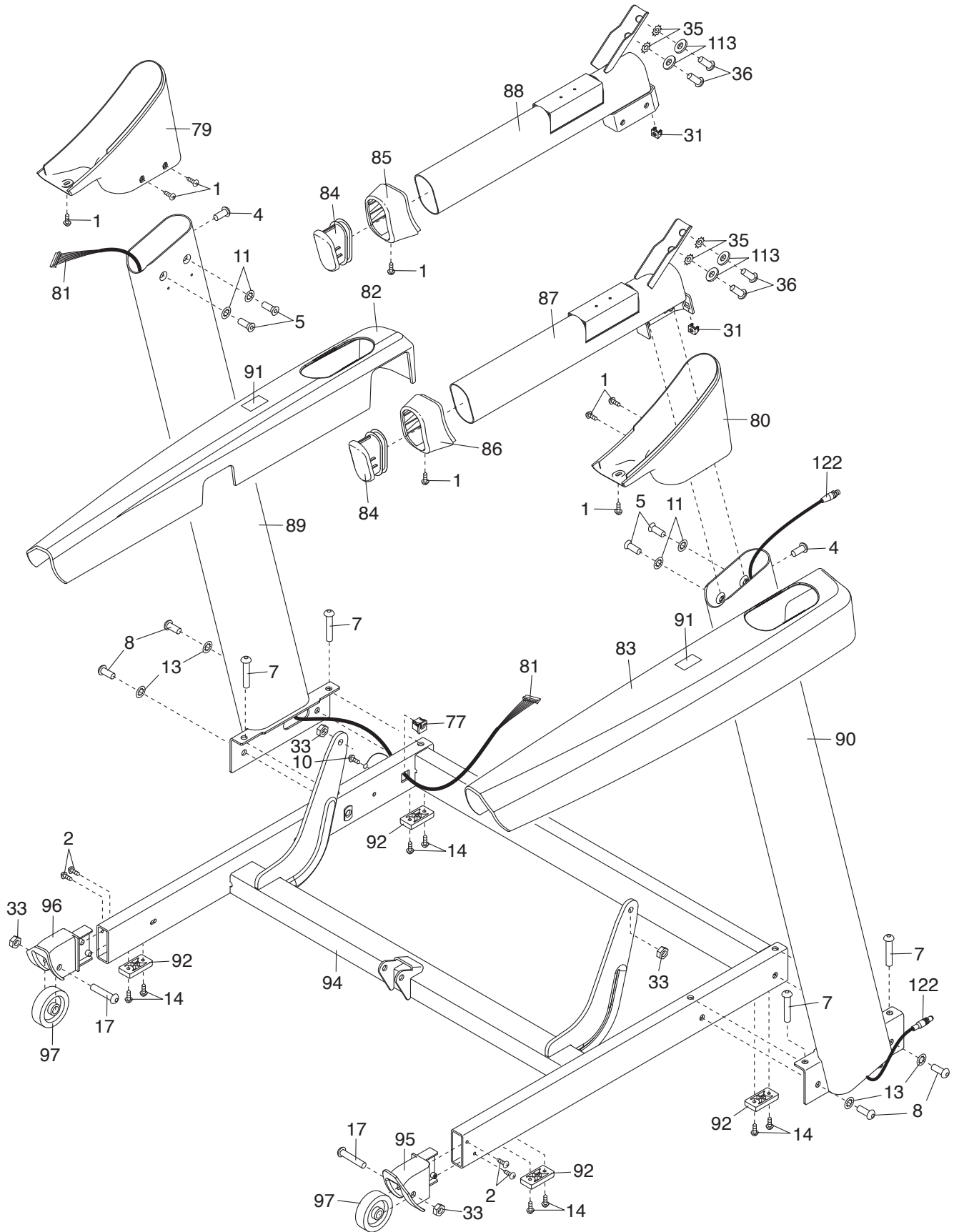

EXPLODED DRAWING D

Model No. PFTL20511.0 R0612A

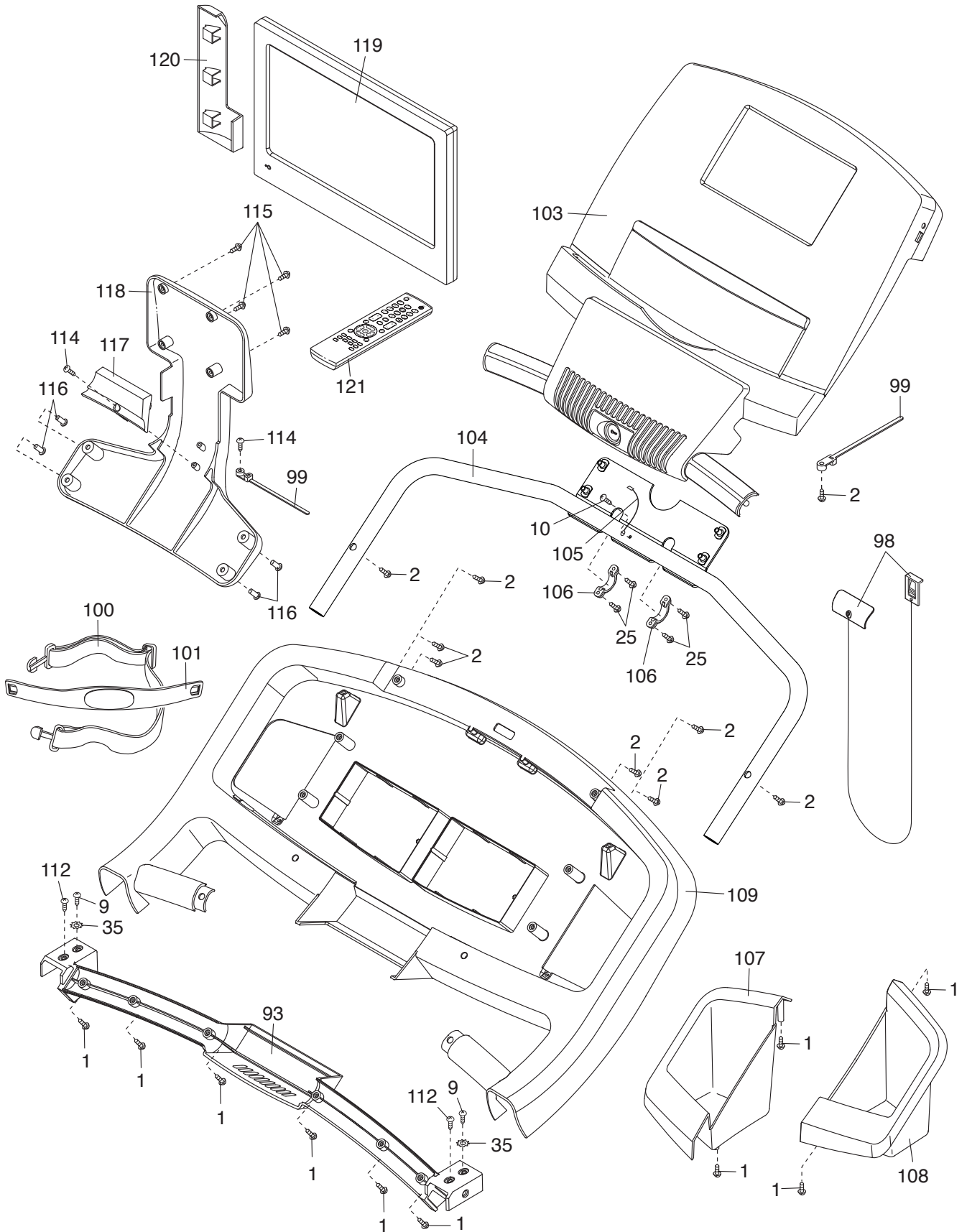

ORDERING REPLACEMENT PARTS

To order replacement parts, please see the front cover of this manual. To help us assist you, be prepared to provide the following information when contacting us:

- the model number and serial number of the product (see the front cover of this manual)
- the name of the product (see the front cover of this manual)
- the key number and description of the replacement part(s) (see the PART LIST and the EXPLODED DRAWING near the end of this manual)

LIMITED WARRANTY

IMPORTANT: You must register this product within 30 days of the purchase date to avoid added fees for service needed under warranty. Go to www.proformservice.com/registration.

ICON Health & Fitness, Inc. (ICON) warrants this product to be free from defects in workmanship and material, under normal use and service conditions. The frame, drive motor, and walking platform are warranted for a lifetime. Parts and electronics are warranted for five (5) years from the date of purchase. Labor is warranted for two (2) years from the date of purchase.

This warranty extends only to the original purchaser (customer). ICON's obligation under this warranty is limited to repairing or replacing, at ICON's option, the product through one of its authorized service centers. All repairs for which warranty claims are made must be preauthorized by ICON. If the product is shipped to a service center, freight charges to and from the service center will be the customer's responsibility. If replacement parts are shipped while the product is under warranty, the customer will be responsible for a minimal handling charge. For in-home service, the customer will be responsible for a minimal trip charge. This warranty does not extend to freight damage to the product. This warranty will automatically be voided if the product is used as a store display model, if the product is purchased or transported outside the USA, if all instructions in this manual are not followed, if the product is abused or improperly or abnormally used, or if the product is used for commercial or rental purposes. No other warranty beyond that specifically set forth above is authorized by ICON.

ICON is not responsible or liable for indirect, special, or consequential damages arising out of or in connection with the use or performance of the product; damages with respect to any economic loss, loss of property, loss of revenues or profits, loss of enjoyment or use, or costs of removal or installation; or other consequential damages of any kind. Some states do not allow the exclusion or limitation of incidental or consequential damages. Accordingly, the above limitation may not apply to the customer.

The warranty extended hereunder is in lieu of any and all other warranties, and any implied warranties of merchantability or fitness for a particular purpose are limited in their scope and duration to the terms set forth herein. Some states do not allow limitations on how long an implied warranty lasts. Accordingly, the above limitation may not apply to the customer.

This warranty provides specific legal rights; the customer may have other rights that vary from state to state.

ICON Health & Fitness, Inc., 1500 S. 1000 W., Logan, UT 84321-9813