

WEIGHT = 271.1 lb
LENGTH = 59"
WIDTH = 50"
HEIGHT = 51"
PAGE 1 OF 11

HAMMER STRENGTH EQUIPMENT

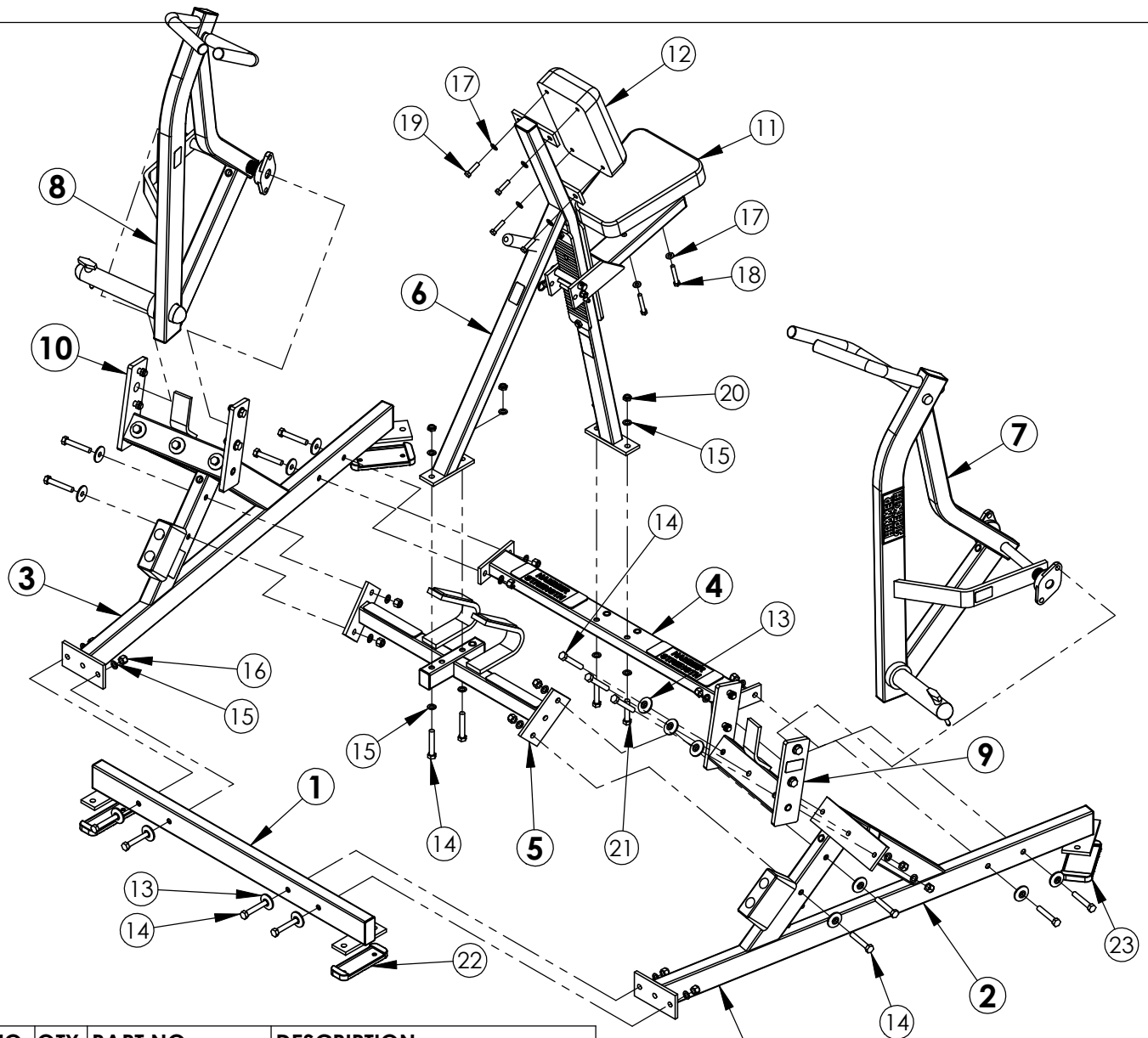

ITEM NO.	QTY.	PART NO.	DESCRIPTION
1	1	ILROW-CFX-0	ASSY, ILROW, FRONT X-MEM
2	1	ILROW-CSFL-0	ASSY, ILROW, LEFT SF
3	1	ILROW-CSFR-0	ASSY, ILROW, RIGHT SF
4	1	ILROW-CBX-0	ASSY, ILROW, BACK FRAME
5	1	ILROW-CTX-0	ASSY, ILROW, FOOT REST
6	1	ILROW-CST-0	ASSY, ILROW, SEAT FRAME
7	1	ILROW-CMAL-2	ASSY, ILROW, LEFT MARM
8	1	ILROW-CMAR-2	ASSY, ILROW, RIGHT MARM
9	1	ILROW-CWBL-0	ASSY, ILROW, LEFT WORKBOX
10	1	ILROW-CWBR-0	ASSY, ILROW, RIGHT WORKBOX
11	1	U-12-5	SEAT PAD
12	1	U-ROW	ROW CHEST PAD
13	18	H-BACK-WASH	BACKING WASHER
14	20	HHB.5X3	1/2 X 3 BOLT
15	26	WASH.5STAR	1/2" INTERNAL LOCK WASHER
16	18	NUT.5LOCK	1/2 DIA THICK LOCK NUT
17	6	WASH.375SAE	3/8" SAE FLAT WASHER
18	2	HHB.375X2.5	STEEL BOLT 3/8 X 2.5
19	4	HHB.375X1.5	STEEL BOLT 3/8 X 1.5
20	4	NUT.5JAMLOCK	1/2 THIN LOCK NUT
21	2	HHB.5X2.5	1/2 X 2 1/2 BOLT
22	2	MM-8	2 X 6 FLANGE RUBBER SLIPPER
23	2	MM-9	3 X 6 FLANGE RUBBER SLIPPER

**HAMMER STRENGTH EQUIPMENT
ILROW-CBX-0, ASSY, ILROW, BACK FRAME**

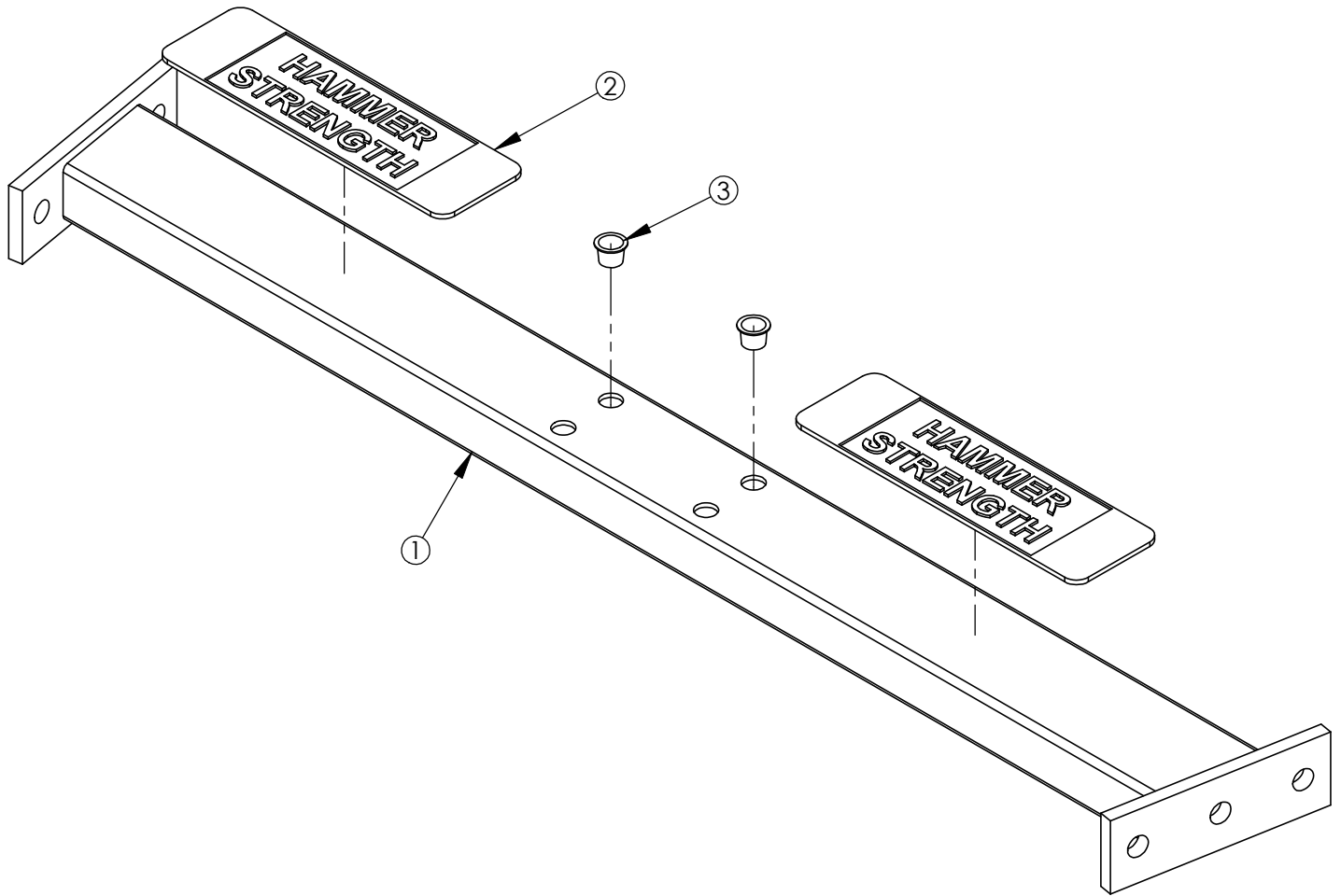

ITEM NO.	QTY.	PART NO.	DESCRIPTION
1	1	ILROW-BX-0	WLDMT, ILROW, BACK FRAME
2	2	H-NONSKID 3X9	PLASTIC NON SKID STRIP 3 X 9
3	2	H-HPLUG (REG)	9/16IN HOLE PLUG

WEIGHT = 14 LB
 LENGTH = 37"
 WIDTH = 6"
 HEIGHT = 2"

HAMMER STRENGTH EQUIPMENT
ILROW-CFX-0, ASSY, ILROW, FRONT X-MEM

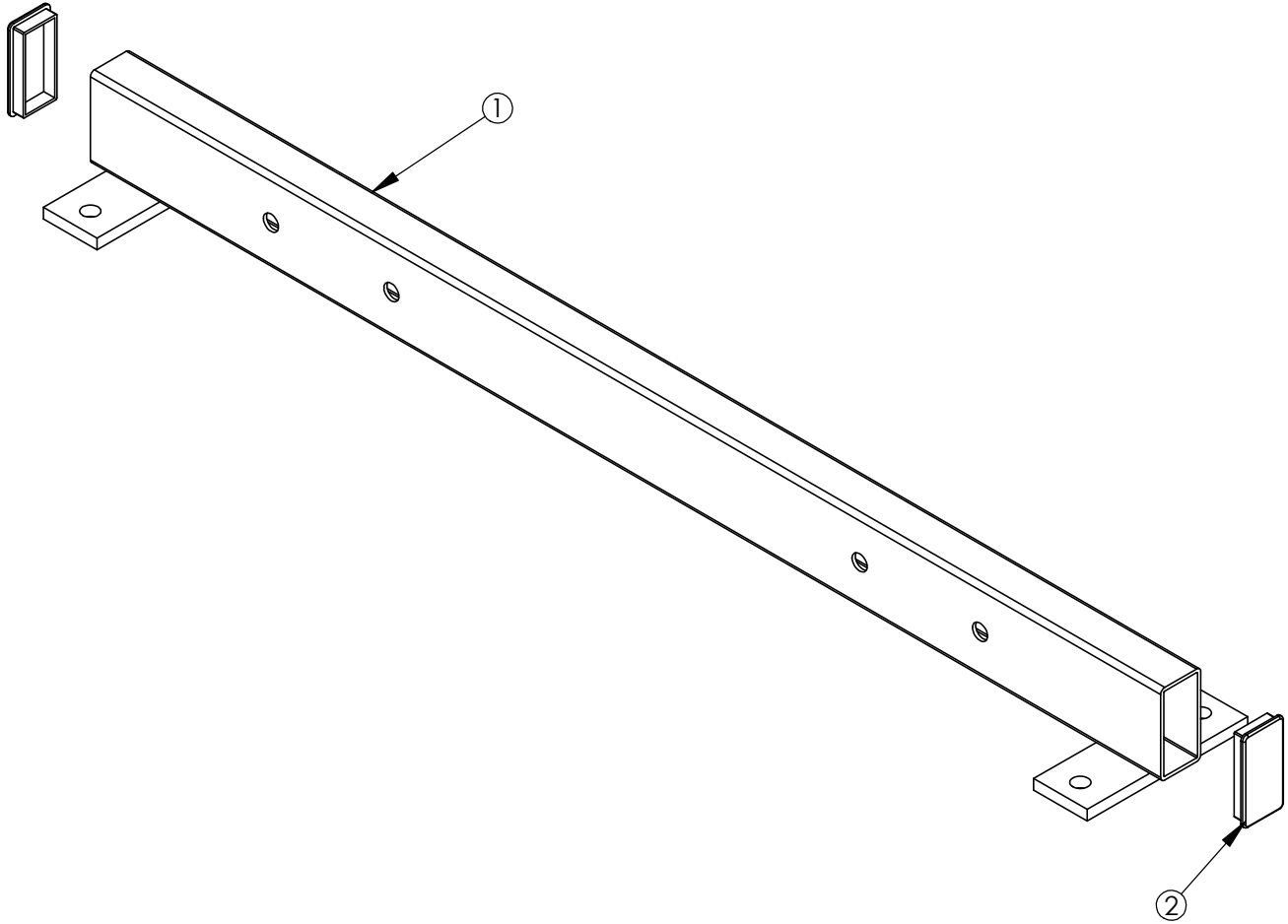

ITEM NO.	QTY.	PART NO.	DESCRIPTION
1	1	ILROW-FX-0	Front Frame
2	2	RC1530-1Q1	1 1/2 X 3 End Cap

WEIGHT = 14 lb
 LENGTH = 40 1/4"
 WIDTH = 6"
 HEIGHT = 3 3/8"

**HAMMER STRENGTH EQUIPMENT
ILROW-CMAL-2, ASSY, ILROW, LEFT MARM**

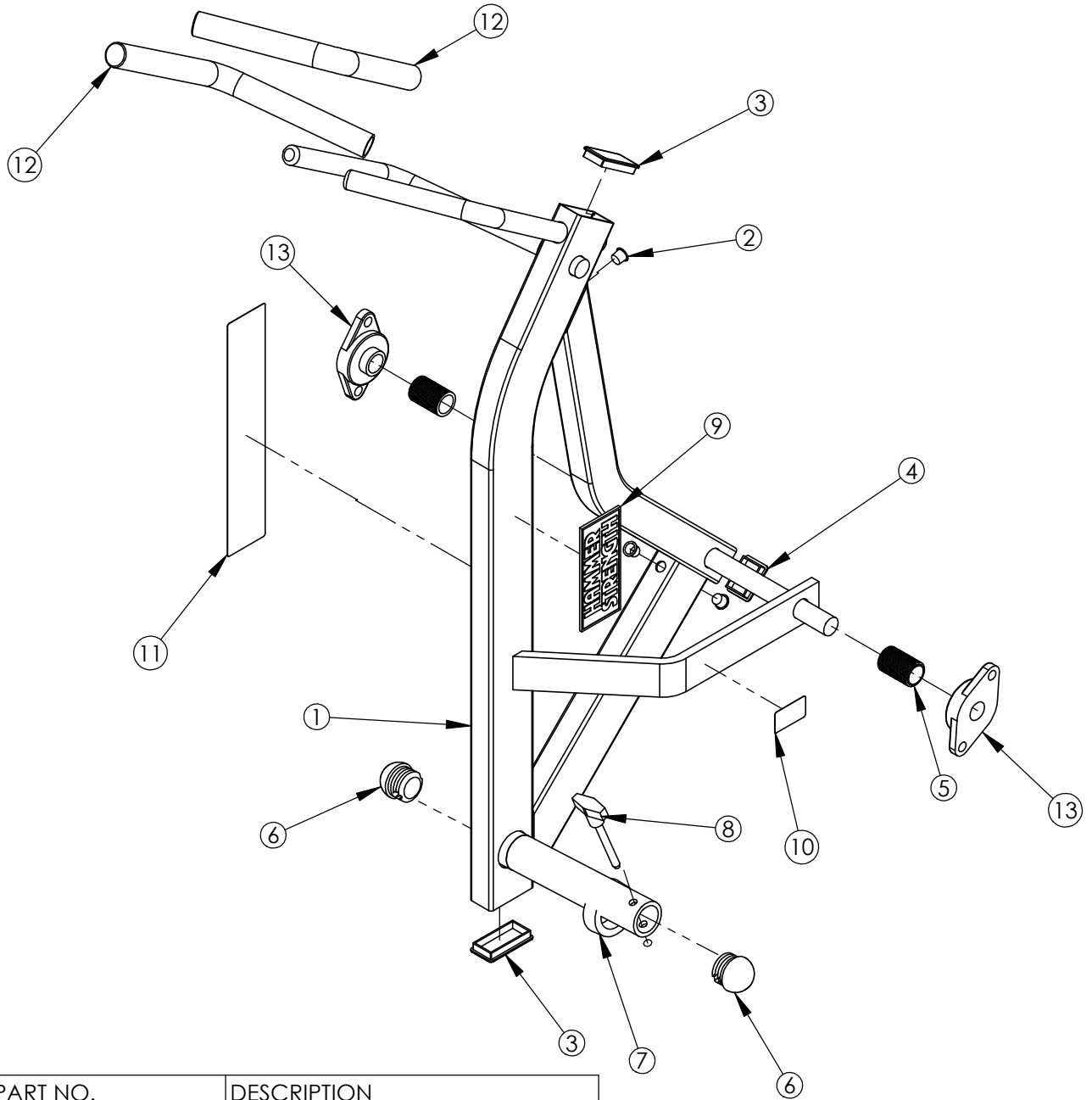

ITEM NO.	QTY.	PART NO.	DESCRIPTION
1	1	ILROW-MAL-1	WLDMT, ILROW, LEFT MARM
2	3	H-HPLUG (REG)	9/16IN HOLE PLUG
3	2	RC1530-1Q1	CAP:1-1/2 X 3 RECTANGLE PLUG
4	1	RC1520-1Q1	CAP:1-1/2 X 2 RECTANGLE PLUG
5	2	ACCORDIAN	SHAFT GUARD
6	2	RUBCAP1-2	RUBBER CAP #1
7	1	H-RUBRNG	MM5 RING
8	1	SELECTOR PIN-3	SELECTOR PIN 3 IN.
9	1	H-NAME PLATE	NAMEPLATE (45156-P)
10	1	8773701	STAY CLEAR DECAL
11	1	IDRW	PRODUCT DECAL
12	2	H-GRIP	HANDLE GRIPS (.938X16)
13	2	H-BEAR-SML	SMALL BEARING

WEIGHT = 42.2 LB
 LENGTH = 22"
 WIDTH = 43 1/2"
 HEIGHT = 20 1/2"

HAMMER STRENGTH EQUIPMENT
ILROW-CSFL-0, ASSY, ILROW, LEFT SF

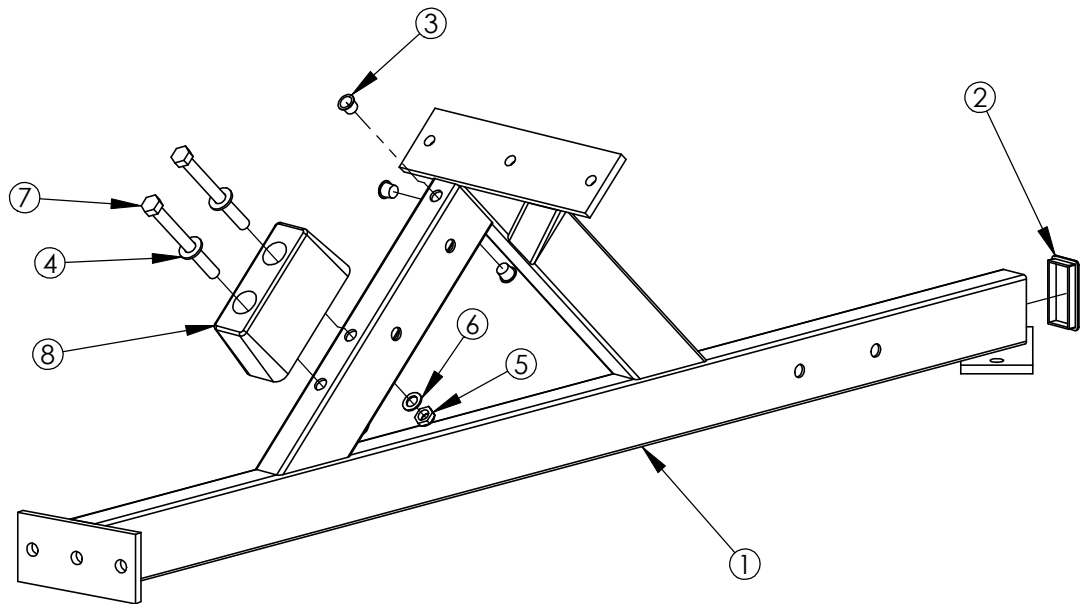

ITEM NO.	QTY.	PART NO.	DESCRIPTION
1	1	ILROW-SFL-0	WLDMT, ILROW, LEFT SIDE FRAME
2	1	RC1530-1Q1	CAP:1-1/2 X 3 RECTANGLE PLUG
3	3	H-HPLUG (REG)	9/16IN HOLE PLUG
4	2	WASH.5SAE	1/2" SAE FLAT WASHER
5	2	NUT.5JAMLOCK	1/2 THIN LOCK NUT
6	2	WASH.5STAR	1/2" INTERNAL LOCK WASHER
7	2	HHB.5X5	1/2 X 5 BOLT
8	1	H-BUMP-LGE	LARGE BUMPER (VEN# MM1)

WEIGHT = 35 lb
 LENGTH = 58"
 WIDTH = 14 1/4"
 HEIGHT = 16 1/2"

**HAMMER STRENGTH EQUIPMENT
ILROW-CST-0, ASSY, ILROW, SEAT FRAME**

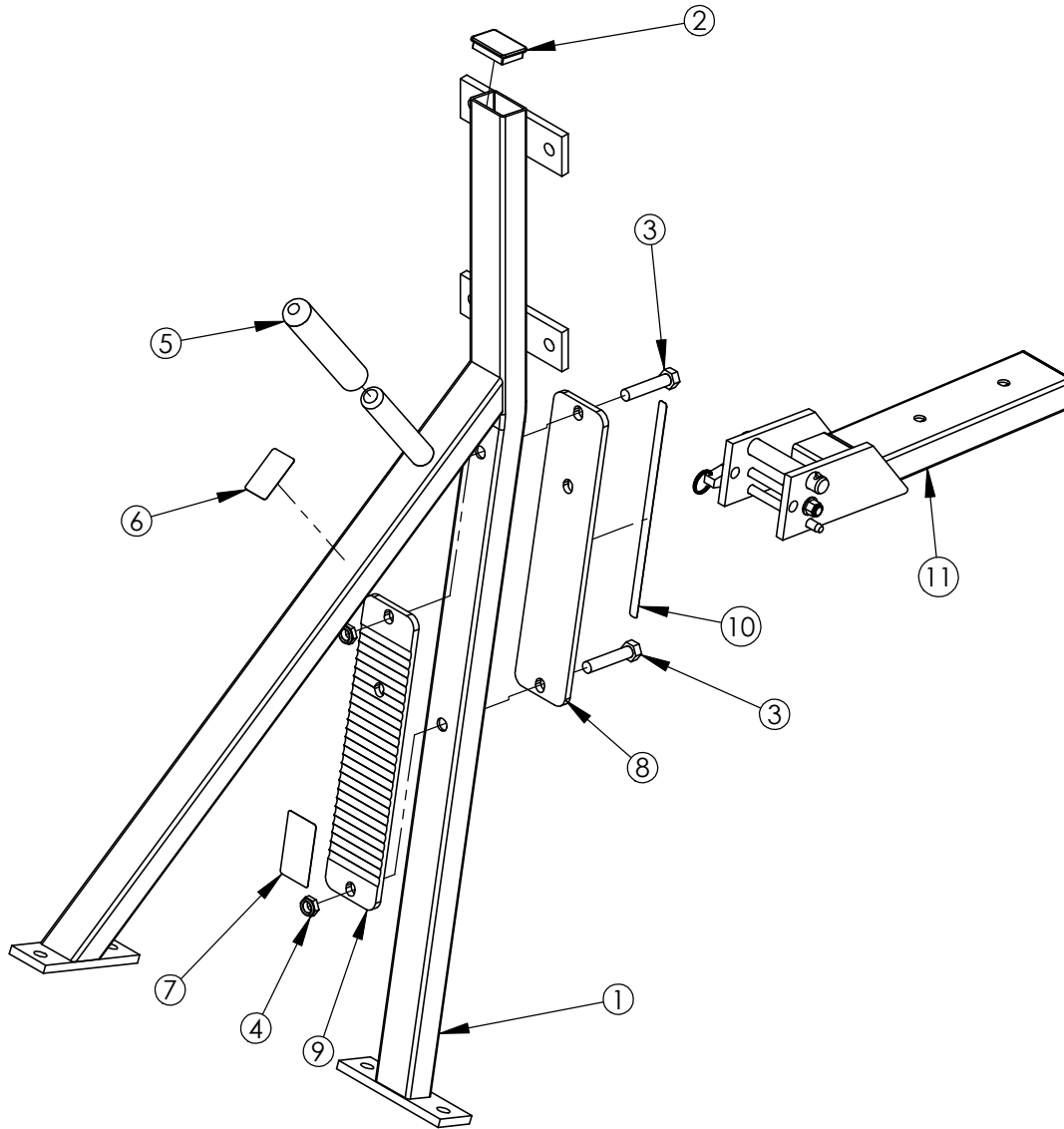

ITEM NO.	QTY.	PART NO.	DESCRIPTION
1	1	ILROW-ST-0	WLDMT, ILROW, SEAT FRAME
2	1	RC1520-1Q1	CAP:1-1/2 X 2 RECTANGLE PLUG
3	2	HHB.5X2.5	1/2 X 2 1/2 BOLT
4	2	NUT.5JAMLOCK	1/2 THIN LOCK NUT
5	1	H-GRIP	HANDLE GRIPS (.938X16)
6	1	STAY CLEAR	STAY CLEAR DECAL
7	1	SERIAL NUMBER	SERIAL NUMBER
8	1	H-SEATRCKS-N	PLASTIC SEAT GUIDES (PP229) NEW)
9	1	H-SEATRCKS-RIB	SEATRACK BACK
10	1	SEAT NUMBER	SEAT ADJ. NUMBER
11	1	CSTD-ST-1	ASSY, STD ST

WEIGHT = 35 LB
 LENGTH = 41"
 WIDTH = 6"
 HEIGHT = 48 5/8"

**HAMMER STRENGTH EQUIPMENT
ILROW-CTX-0, ASSY, ILROW, FOOT REST**

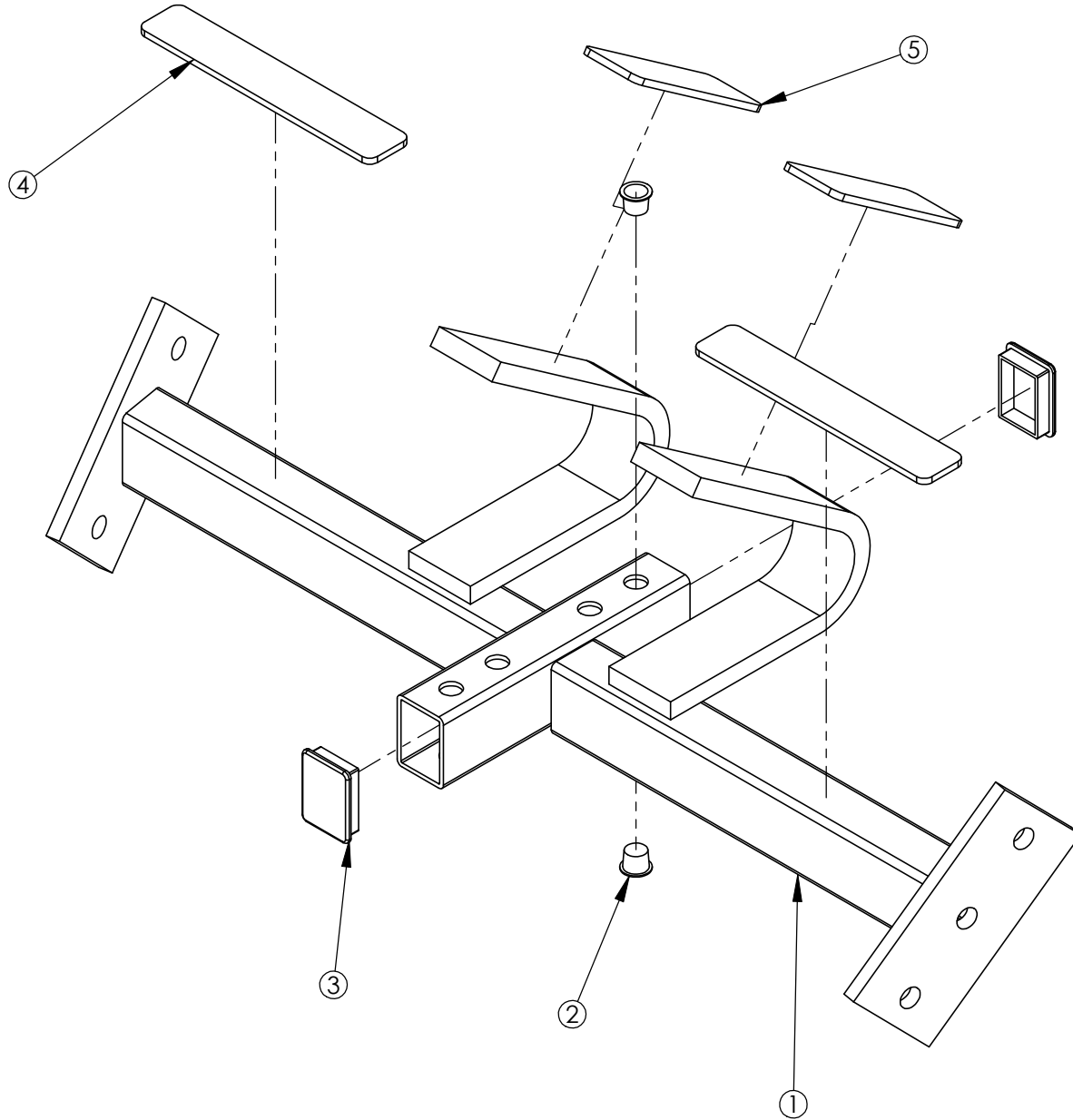

ITEM NO.	QTY.	PART NO.	DESCRIPTION
1	1	ILROW-TX-0	WLDMT, ILROW, FOOT REST
2	2	H-HPLUG (REG)	9/16IN HOLE PLUG
3	2	RC1520-1Q1	CAP:1-1/2 X 2 RECTANGLE PLUG
4	2	H-PLATE-G1	SMALL PLATE GUARD
5	2	H-PLATE-G2(CUT)	Medium Plate Guard

WEIGHT = 20 LB
 LENGTH = 10 3/8"
 WIDTH = 28 1/2"
 HEIGHT = 10 1/2"

HAMMER STRENGTH EQUIPMENT
ILROW-CWBL-0, ASSY, ILROW, LEFT WORKBOX

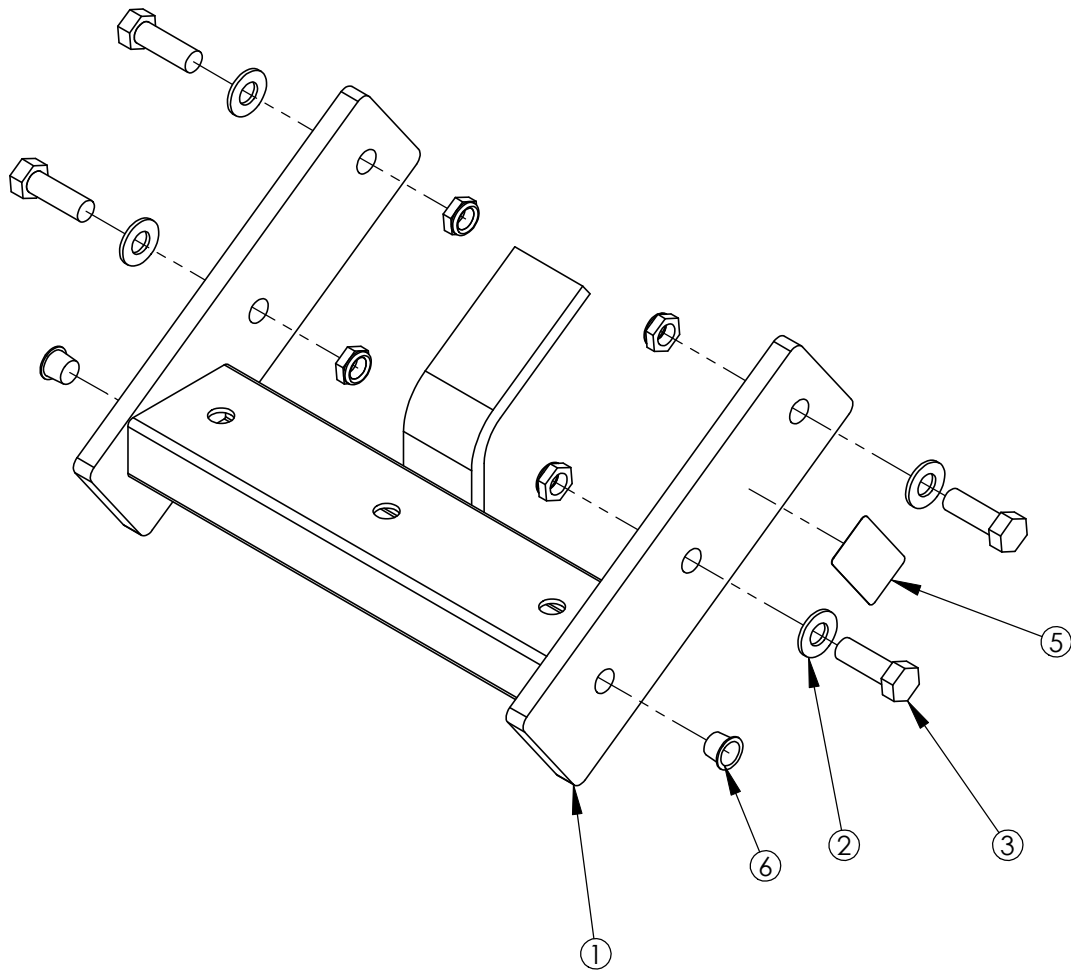

ITEM NO.	QTY.	PART NO.	DESCRIPTION
1	1	ILROW-WB-0	WLDMT, ILROW, WORKBOX
2	4	WASH.5SAE	1/2" SAE FLAT WASHER
3	4	HHB.5X1.5	BOLT, HEX HEAD 1/2 X 1-1/2
4	4	NUT.5JAMLOCK	1/2 THIN LOCK NUT
5	1	STAY CLEAR	STAY CLEAR DECAL
6	2	H-HPLUG (REG)	9/16IN HOLE PLUG

WEIGHT = 14LB
 LENGTH = 14 1/2"
 WIDTH = 3"
 HEIGHT = 10"

HAMMER STRENGTH EQUIPMENT
CSTD-ST-1: ASSY, STD ST

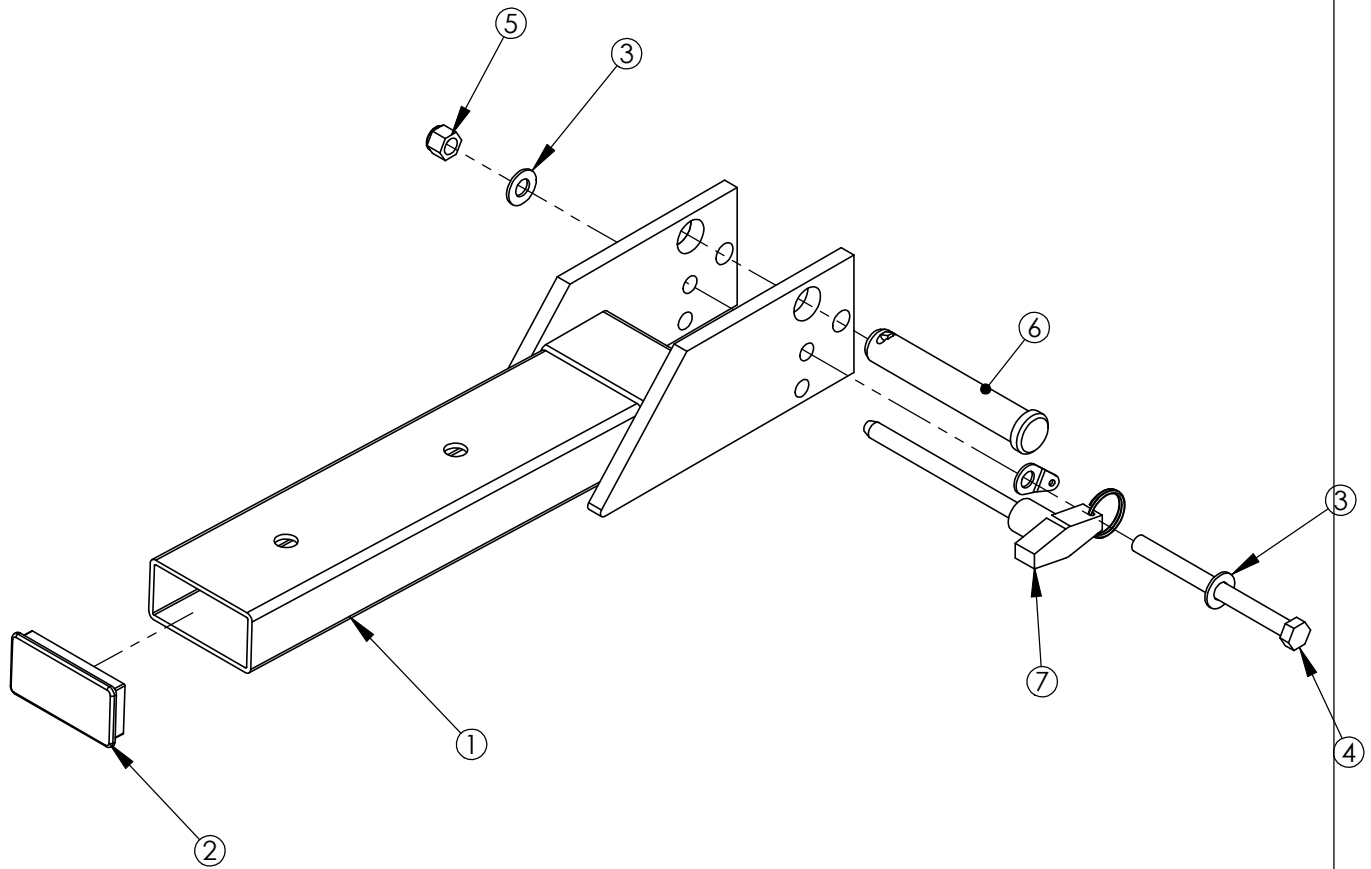

ITEM NO.	QTY.	PART NO.	DESCRIPTION
1	1	STD-ST	Standard Seat #1
2	1	RC1530-1Q1	CAP:1-1/2 X 3 RECTANGLE PLUG
3	2	WASH.375SAE	3/8" SAE FLAT WASHER
4	1	HHB.375X4.5	STEEL BOLT 3/8 X 4.5
5	1	NUT.375LOCK	3/8 THICK LOCK NUT
6	1	STD SEAT PIN	LONG SEAT PIN (HDADJ)
7	1	SELECTPIN	ASSY, STD SEAT SELECTOR PIN

WEIGHT = 9 lb
 LENGTH = 17"
 WIDTH = 4 3/4"
 HEIGHT = 3"

**HAMMER STRENGTH EQUIPMENT
H-HORN-ASSY: WEIGHT HORN ASSEMBLY**

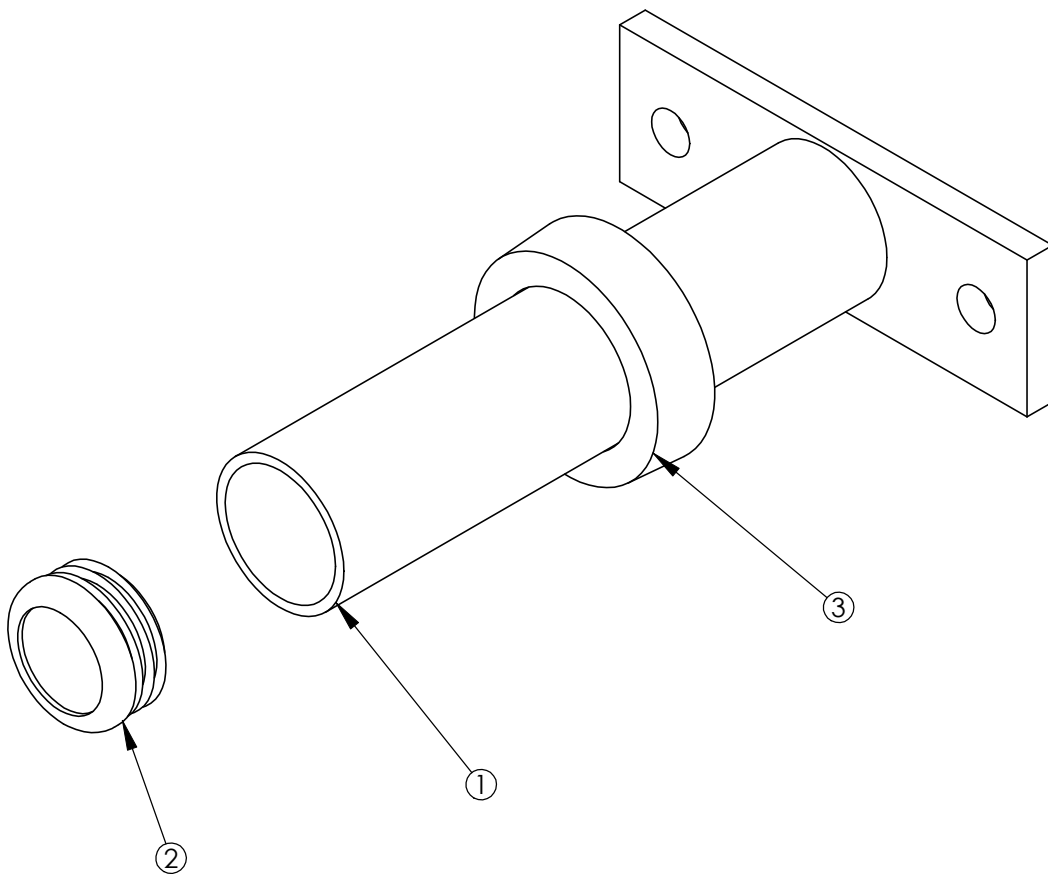

ITEM NO.	QTY.	PART NO.	DESCRIPTION
1	1	H-HORN	WLDMT, WEIGHT HORN
2	1	8078001	CAP, END 1.75 DIA RD 14-20 GA
3	1	H-RUBRNG	MM5 RING

WEIGHT = 3 1/4 lb
 LENGTH = 8 5/8"
 WIDTH = 6"
 HEIGHT = 3"