

WEIGHT = 371 lb
LENGTH = 45"
WIDTH = 69"
HEIGHT = 69"

HAMMER STRENGTH EQUIPMENT ILWC EXPLODED

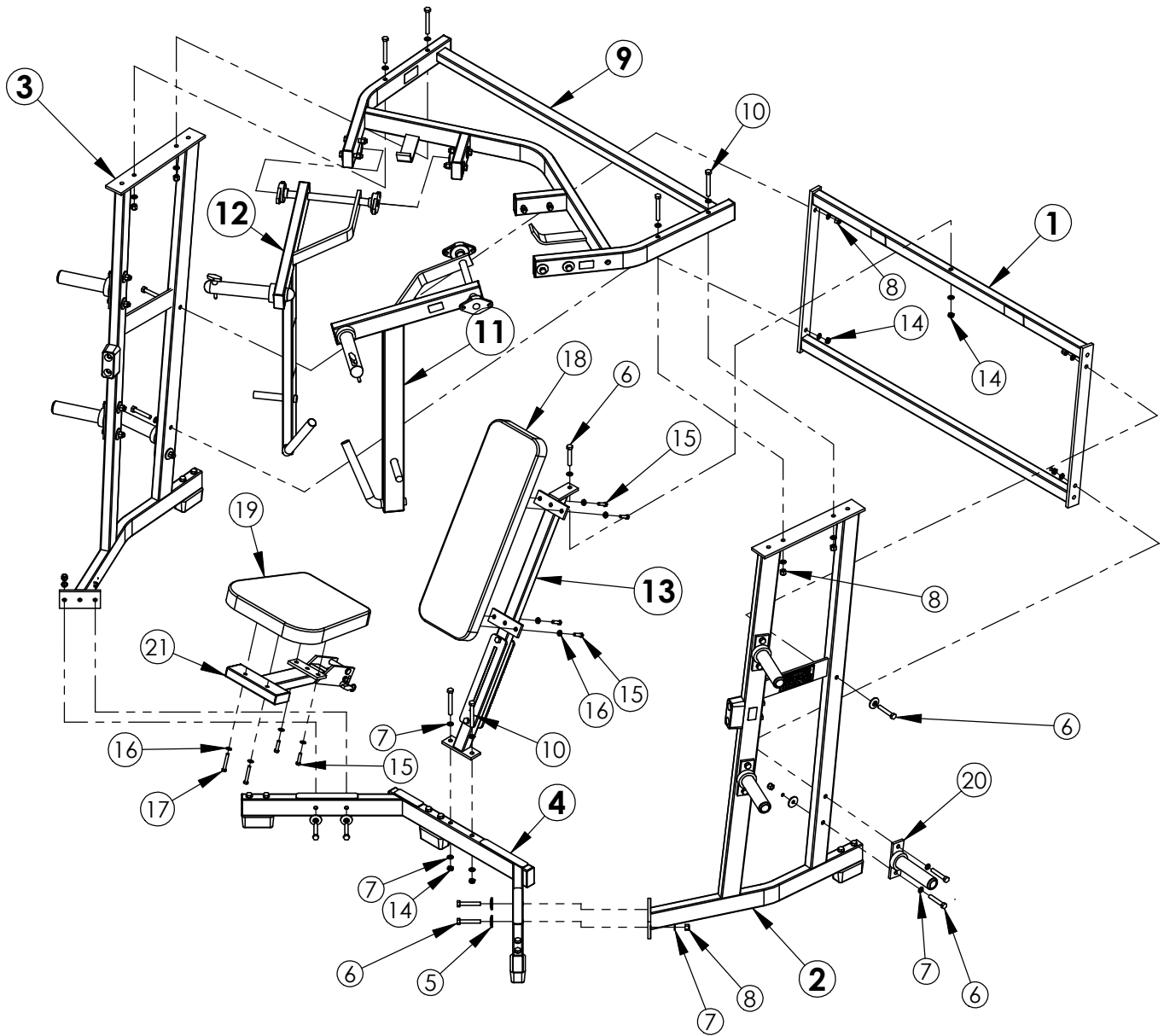

ITEM NO.	QTY.	PART NO.	DESCRIPTION
1	1	ILWC-CBX-0	ASSY, ILWC, BOTTOM X-FRAME
2	1	ILWC-CSFL-1	ASSY, ILWC, LEFT SIDE FRAME
3	1	ILWC-CSFR-1	ASSY, ILWC, RIGHT SIDE FRAME
4	1	ILWC-CFX-0	ASSY, ILWC, FRONT X-FRAME
5	16	H-BACK-WASH	BACKING WASHER
6	19	HHB.5X3	1/2 X 3 BOLT
7	34	WASH.5STAR	1/2" INTERNAL LOCK WASHER
8	20	NUT.5LOCK	1/2 DIA THICK LOCK NUT
9	1	ILWC-CTX-0	ASSY, ILWC, WORKBOX
10	6	HHB.5X4	1/2 X 4 BOLT
11	1	ILWC-CMAL-3	ASSY, ILWC, LEFT MARM
12	1	ILWC-CMAR-3	ASSY, ILWC, RIGHT MARM
13	1	ILWC-CST-0	ASSY, ILWC, SEAT FRAME
14	5	NUT.5JAMLOCK	1/2 THIN LOCK NUT
15	6	HHB.375X1.5	STEEL BOLT 3/8 X 1.5
16	8	WASH.375SAE	3/8" SAE FLAT WASHER
17	2	HHB.375X2.5	STEEL BOLT 3/8 X 2.5
18	1	U-33-19	BACK PAD
19	1	U-16-11	16X11 PAD
20	6	H-HORN-ASSY	ASSY, WEIGHT HORN
21	1	CSTD-ST3-1	ASSY, STD SEAT #3

**HAMMER STRENGTH EQUIPMENT
 ILWC-CBX-0, ASSY, ILWC, BOTTOM X-FRAME**

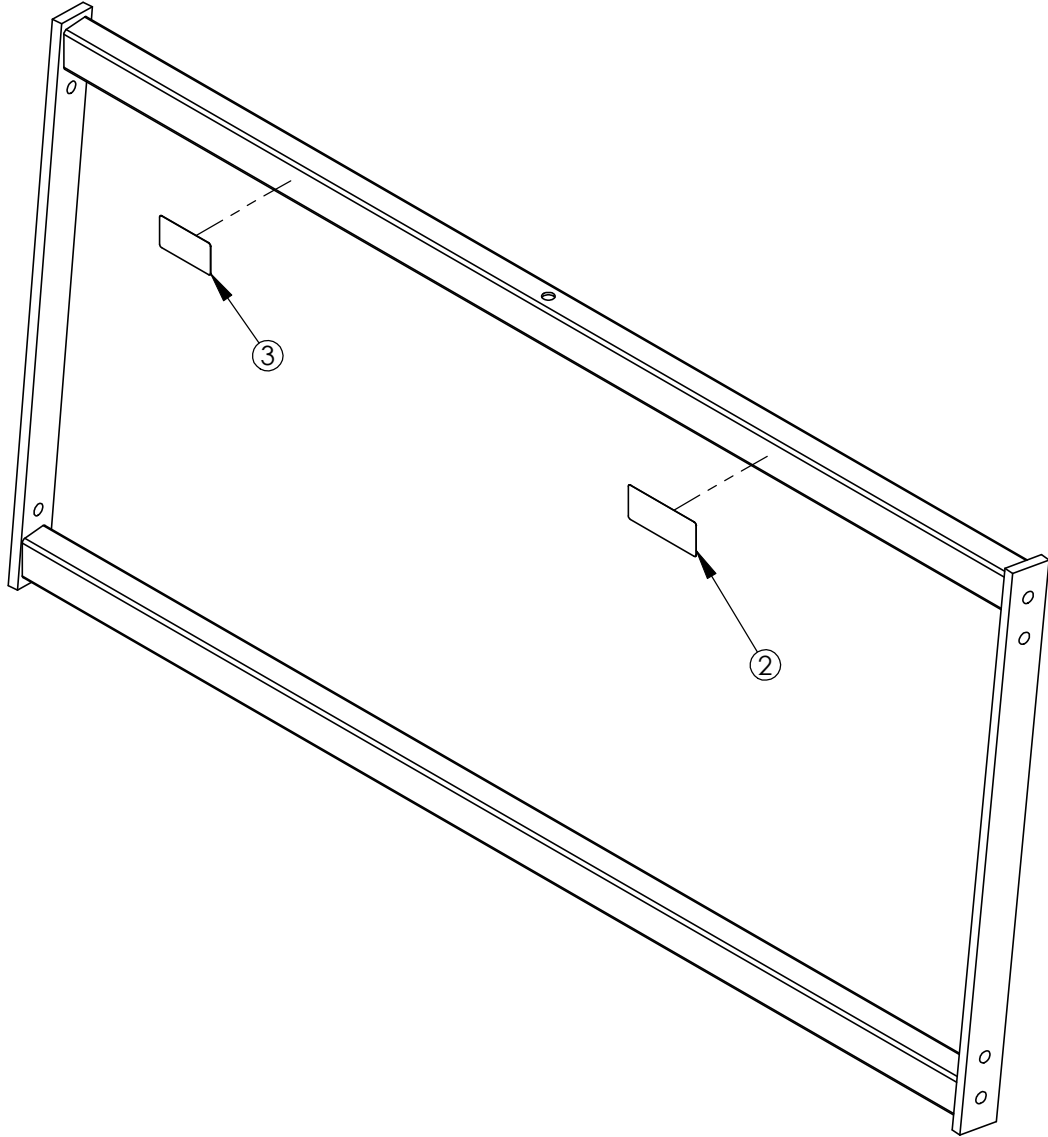

WEIGHT = 40 lb
 LENGTH = 56 1/2"
 WIDTH = 27 1/2"
 HEIGHT = 2"

ITEM NO.	QTY.	PART NO.	DESCRIPTION
2	1	8773701	ASTM LABEL
3	1	PATENT	PATENT DECAL

HAMMER STRENGTH EQUIPMENT
ILWC-CFX-0, ASSY, ILWC, FRONT X-FRAME

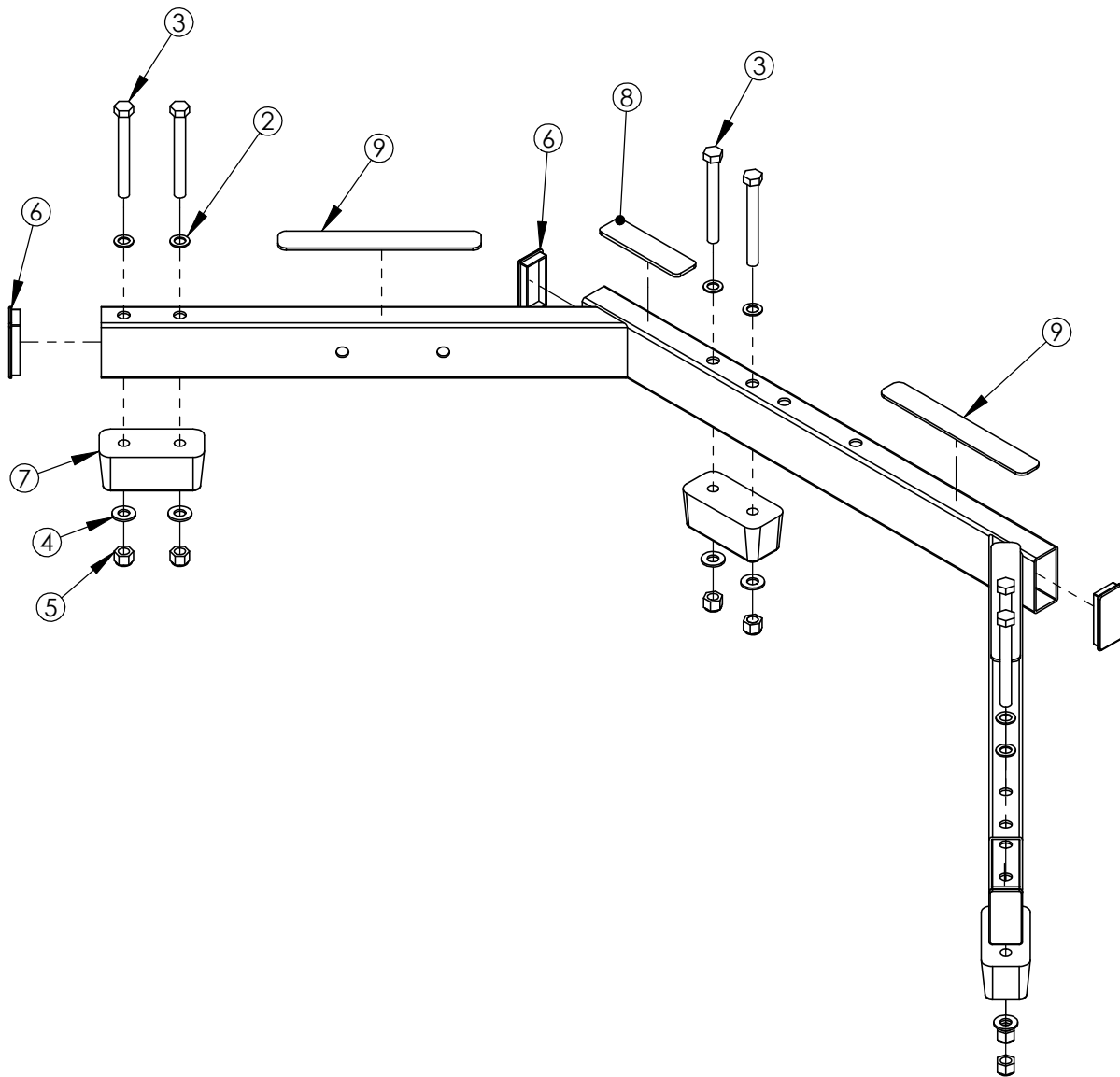

ITEM NO.	QTY.	PART NO.	DESCRIPTION
2	6	WASH.5STAR	1/2" INTERNAL LOCK WASHER
3	6	HHB.5X4.5	1/2 X 4 1/2 BOLT
4	6	WASH.5SAE	1/2" SAE FLAT WASHER
5	6	NUT.5LOCK	1/2 DIA THICK LOCK NUT
6	4	RC1530-1Q1	CAP:1-1/2 X 3 RECTANGLE PLUG
7	3	H-BUMP-MED	MM2 MEDIUM
8	1	H-PLATE-G1	SMALL PLATE GUARD
9	3	NONSKID 1 X 9	PLASTIC NON SKID STRIP 1 X 9

WEIGHT = 26 lb
 LENGTH = 58 1/4"
 WIDTH = 18 1/8"
 HEIGHT = 5 1/8"

**HAMMER STRENGTH EQUIPMENT
ILWC-CMAL-3, ASSY, ILWC, LEFT MARM**

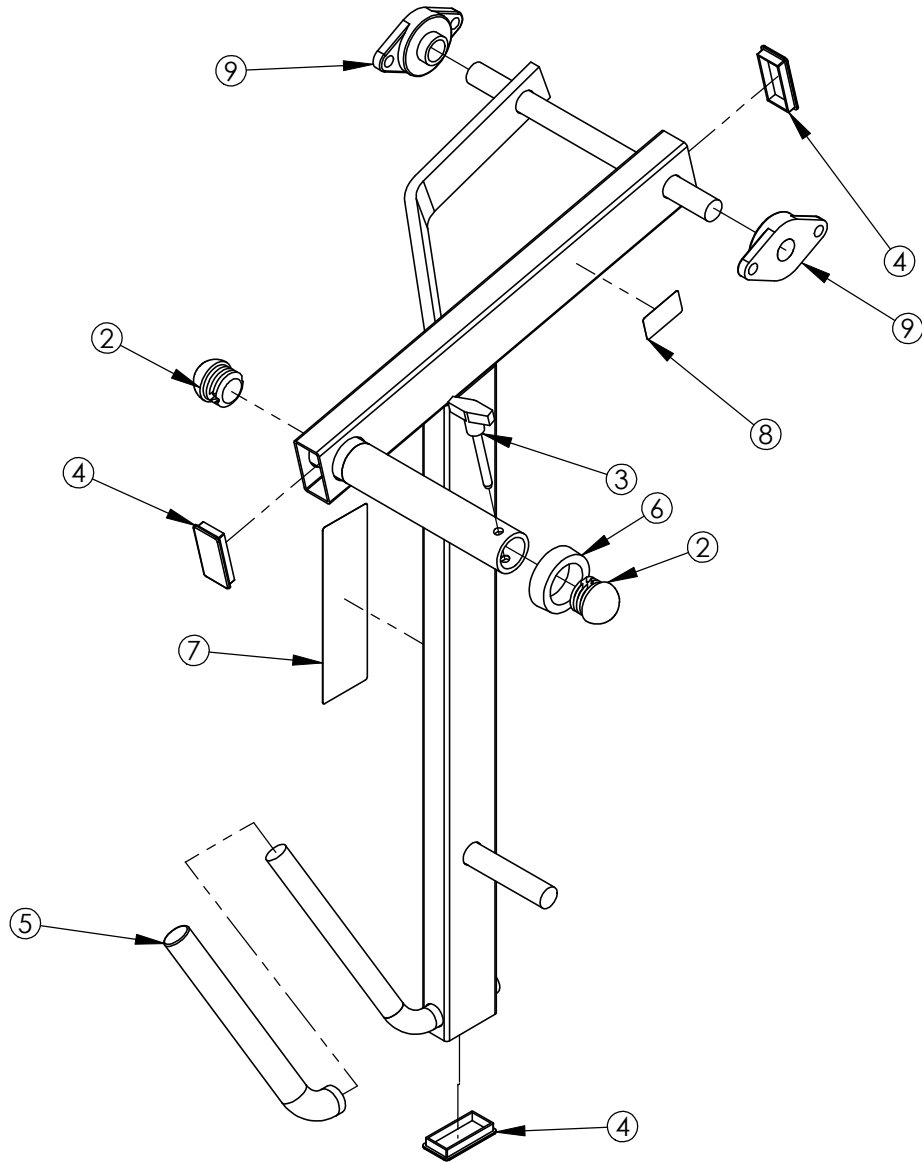

ITEM NO.	QTY.	PART NO.	DESCRIPTION
2	2	RUBCAP1-2	RUBBER CAP #1
3	1	SELECTOR PIN-3	SELECTOR PIN 3 IN.
4	3	RC1530-1Q1	CAP:1-1/2 X 3 RECTANGLE PLUG
5	1	H-GRIP	HANDLE GRIPS (.938X16)
6	1	H-RUBRNG	MM5 RING
7	1	IDWC	PRODUCT DECAL
8	1	STAY CLEAR	STAY CLEAR DECAL
9	2	H-BEAR-SML	SMALL BEARING

WEIGHT = 34 LB
 LENGTH = 22 5/8"
 WIDTH = 39"
 HEIGHT = 21 3/4"

HAMMER STRENGTH EQUIPMENT
ILWC-CSFL-1, ASSY, ILWC, LEFT SIDE FRAME

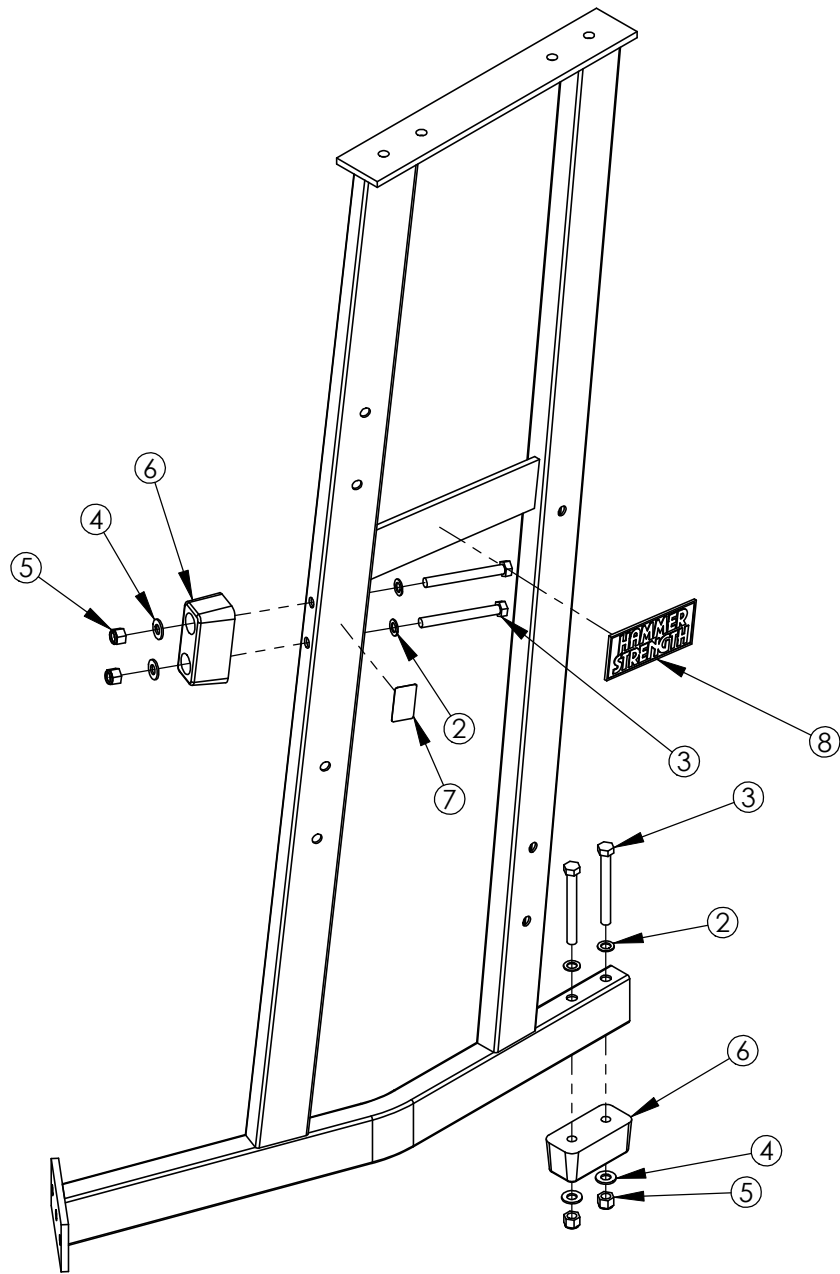

ITEM NO.	QTY.	PART NO.	DESCRIPTION
2	4	WASH.5STAR	1/2" INTERNAL LOCK WASHER
3	4	HHB.5X4.5	1/2 X 4 1/2 BOLT
4	4	WASH.5SAE	1/2" SAE FLAT WASHER
5	4	NUT.5LOCK	1/2 DIA THICK LOCK NUT
6	2	H-BUMP-MED	MM2 MEDIUM
7	1	STAY CLEAR	STAY CLEAR DECAL
8	1	H-NAME PLATE	NAMEPLATE (45156-P)

WEIGHT = 58 lb
 LENGTH = 36 7/8"
 WIDTH = 65 3/4"
 HEIGHT = 10 1/8"

**HAMMER STRENGTH EQUIPMENT
ILWC-CST-0, ASSY, ILWC, SEAT FRAME**

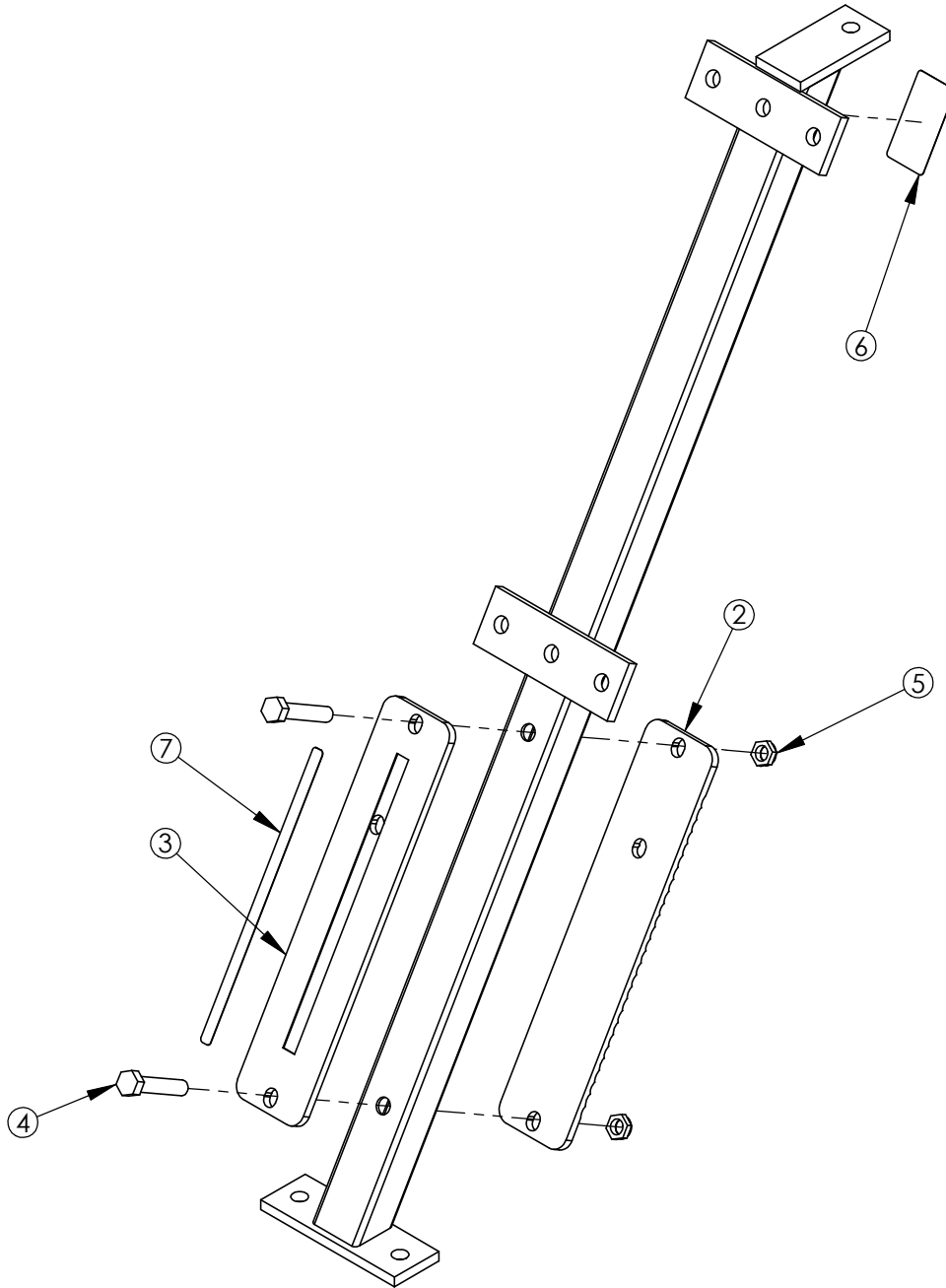

ITEM NO.	QTY.	PART NO.	DESCRIPTION
2	1	H-SEATRCKS-RIB	SEATRACK BACK
3	1	H-SEATRCKS-N	PLASTIC SEAT GUIDES (PP229) NEW)
4	2	HHB.5X2.5	1/2 X 2 1/2 BOLT
5	2	NUT.5JAMLOCK	1/2 THIN LOCK NUT
6	1	SERIAL NUMBER	SERIAL NUMBER
7	1	SEAT NUMBER	SEAT ADJ. NUMBER

WEIGHT = 16.5 lb
 LENGTH = 43 1/8"
 WIDTH = 6"
 HEIGHT = 4"

HAMMER STRENGTH EQUIPMENT ILWC-CTX-0, ASSY, ILWC, WORKBOX

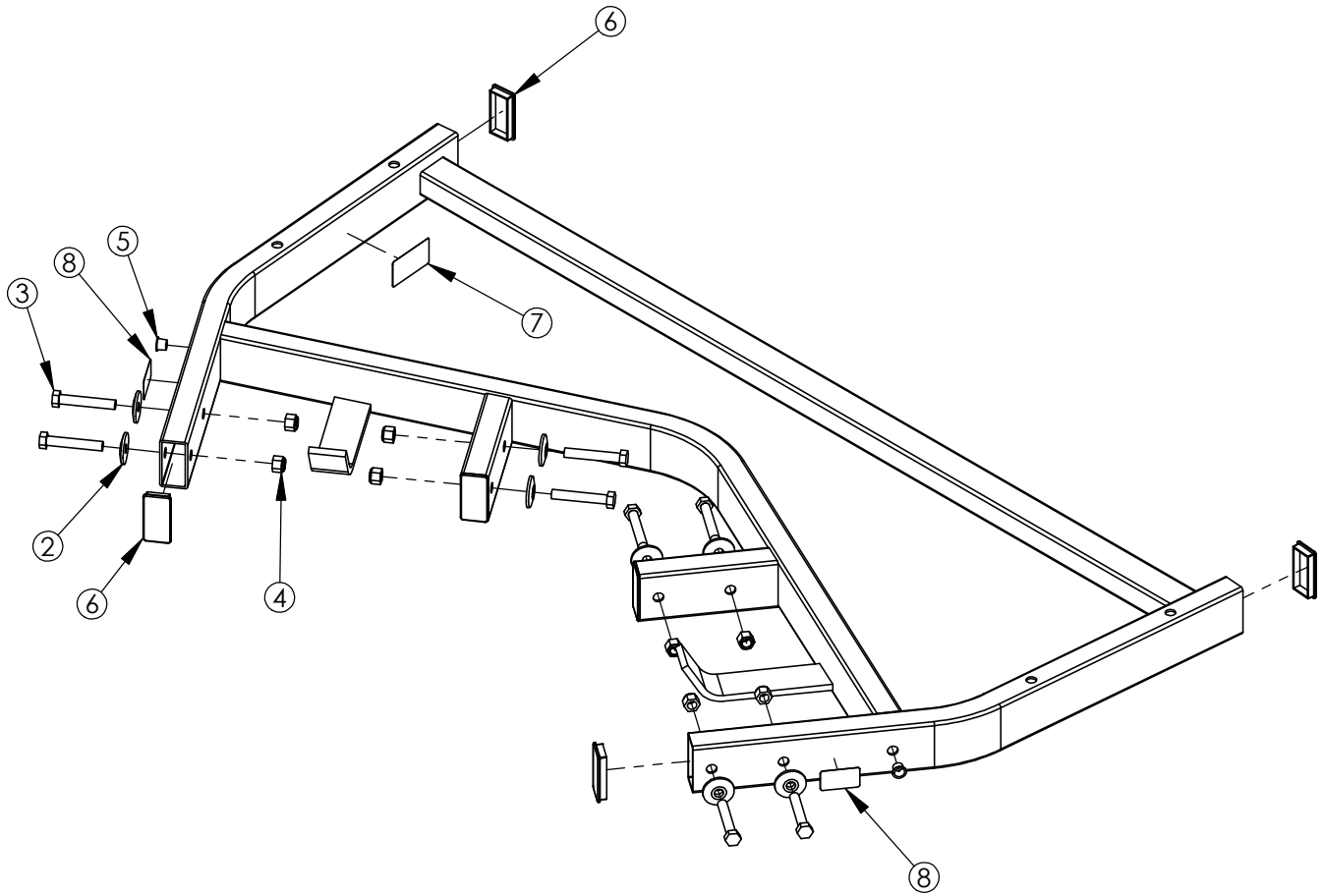

ITEM NO.	QTY.	PART NO.	DESCRIPTION
2	8	H-BACK-WASH	BACKING WASHER
3	8	HHB.5X3	1/2 X 3 BOLT
4	8	NUT.5LOCK	1/2 DIA THICK LOCK NUT
5	2	H-HPLUG (REG)	9/16IN HOLE PLUG
6	6	RC1530-1Q1	CAP:1-1/2 X 3 RECTANGLE PLUG
7	1	PATENT	PATENT DECAL
8	2	STAY CLEAR	STAY CLEAR DECAL

WEIGHT = 59 lb
 LENGTH = 60 3/8"
 WIDTH = 31 1/4"
 HEIGHT = 3 1/8"

**HAMMER STRENGTH EQUIPMENT
CSTD-ST3-1, ASSY, STD SEAT #3**

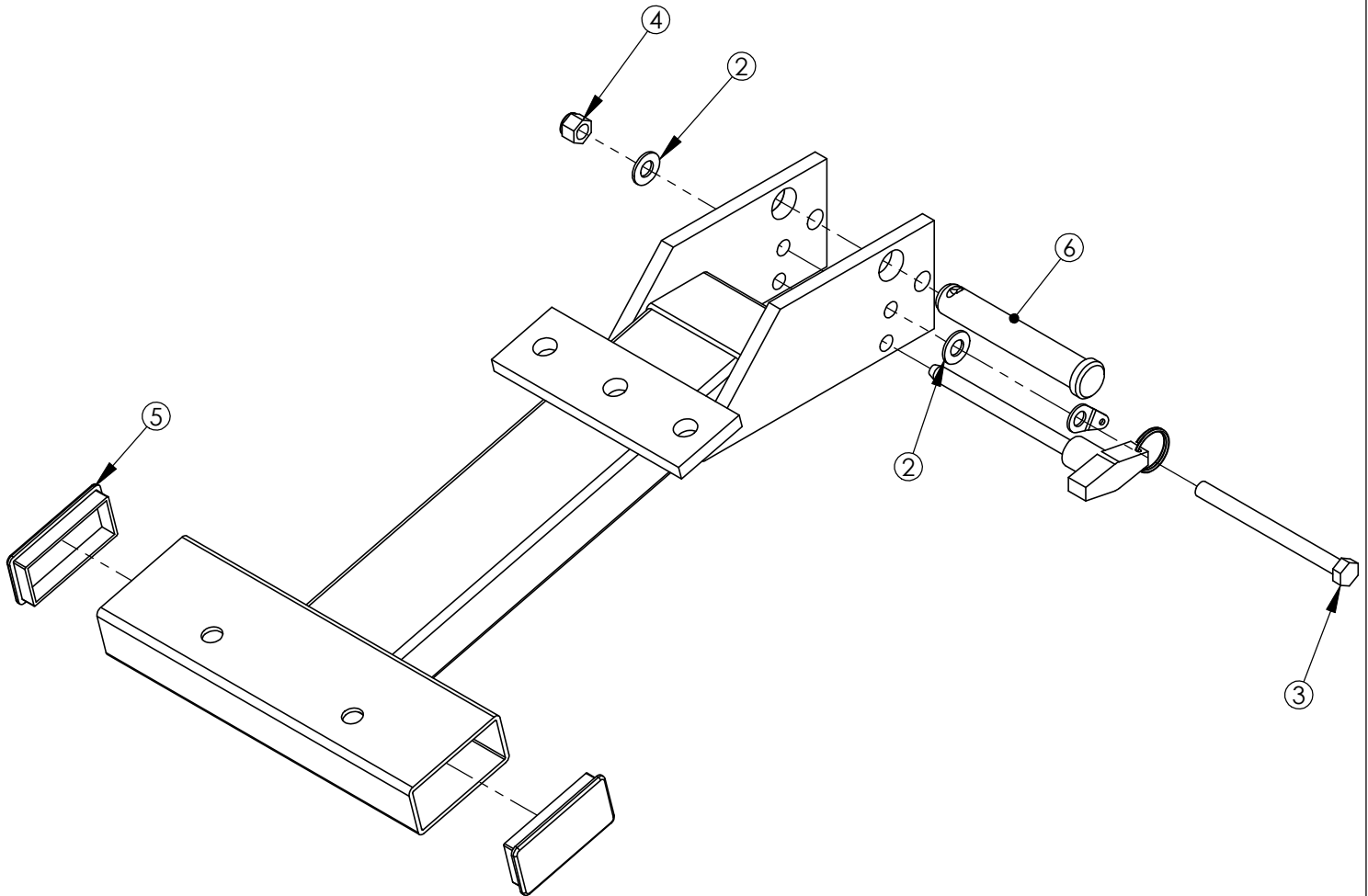

ITEM NO.	QTY.	PART NO.	DESCRIPTION
2	2	WASH.375SAE	3/8" SAE FLAT WASHER
3	1	HHB.375X4.5	STEEL BOLT 3/8 X 4.5
4	1	NUT.375LOCK	3/8 THICK LOCK NUT
5	2	RC1530-1Q1	CAP:1-1/2 X 3 RECTANGLE PLUG
6	1	STD SEAT PIN	STD SEAT PIN
7	1	SELECTPIN	ASSY, STD SEAT SELECTOR PIN

WEIGHT = 13 lb
 LENGTH = 20 1/2"
 WIDTH = 10 1/4"
 HEIGHT = 4 1/4"

**HAMMER STRENGTH EQUIPMENT
H-HORN-ASSY, ASSY, WEIGHT HORN**

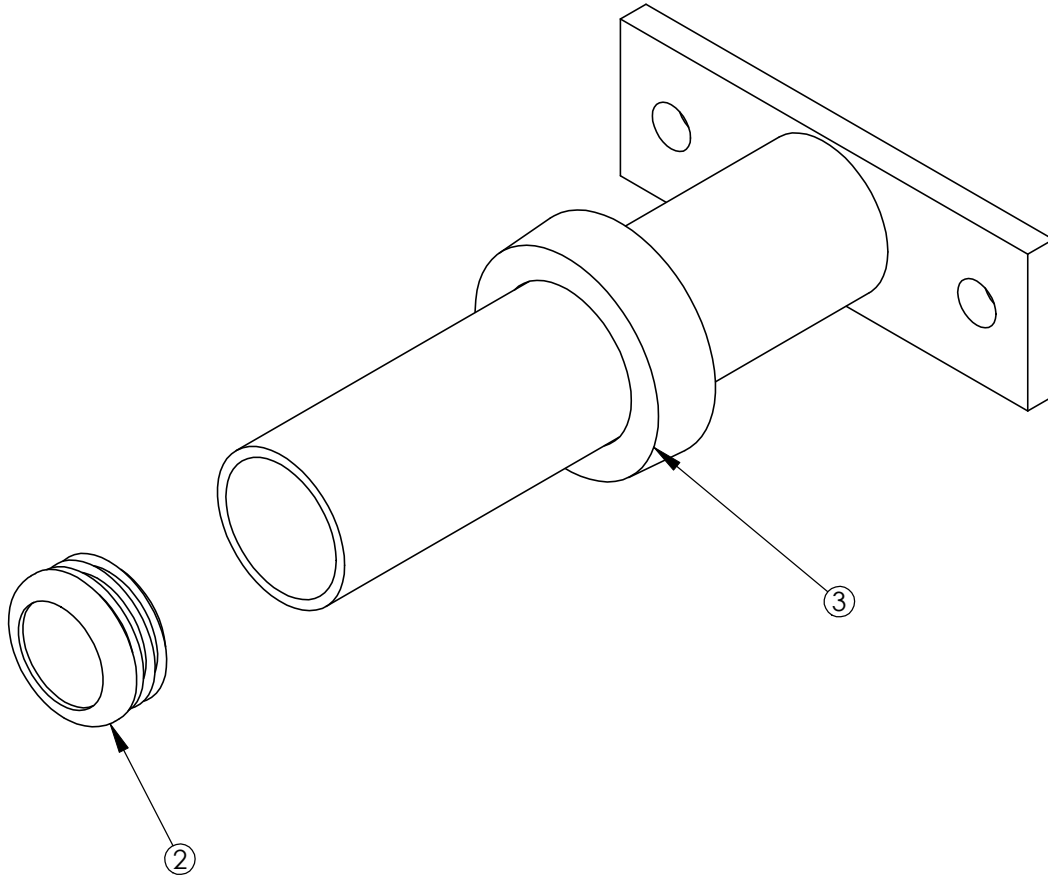

WEIGHT = 3 1/4 lb
 LENGTH = 8 5/8"
 WIDTH = 6"
 HEIGHT = 3"

ITEM NO.	QTY.	PART NO.	DESCRIPTION
2	1	8078001	CAP, END 1.75 DIA RD 14-20 GA
3	1	H-RUBRNG	MM5 RING