

PARABODY®

220 GYM SYSTEM

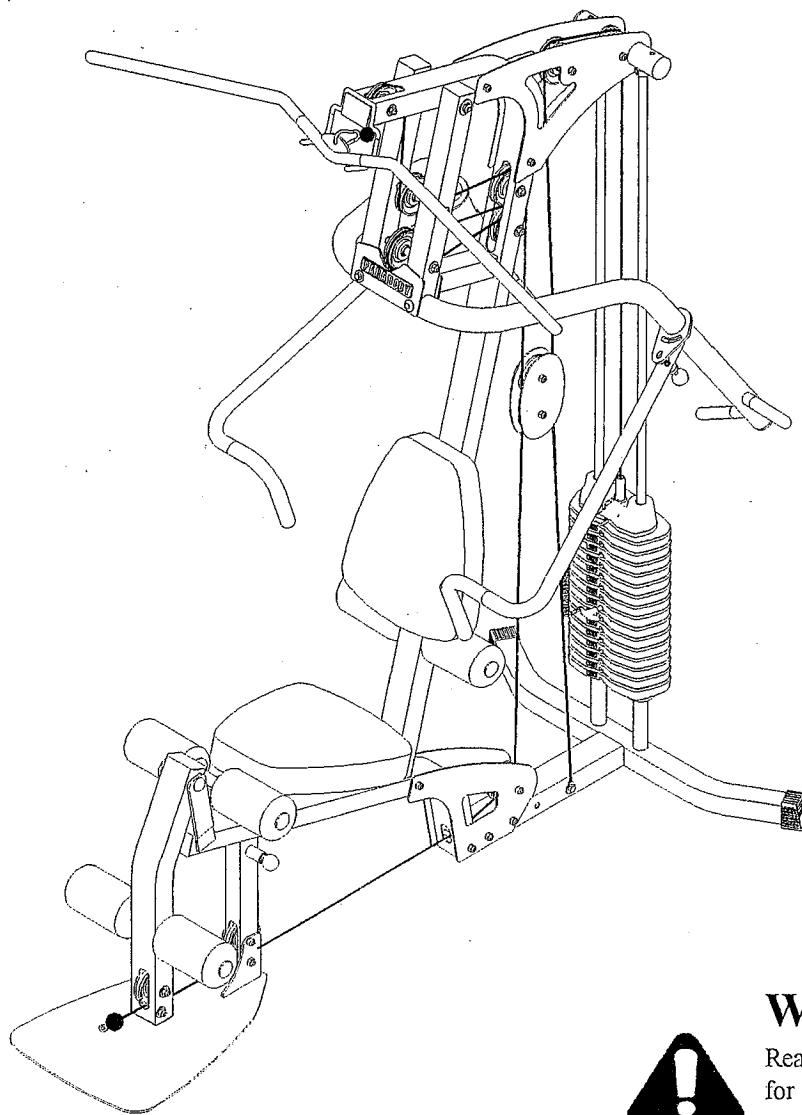

WARNING:

Read and follow all directions for each step to insure proper assembly of this product.



USER'S GUIDE

TABLE OF CONTENTS

Safety Statement.....	2	Parts list.....	5
General Notes.....	3	Assembly Instructions.....	6-21
Tools Required.....	3	General Maintenance.....	22
Gym Layout.....	4	Warranty Statement.....	23
		Product Services.....	24
		Insert-Registration Card	

IMPORTANT SAFETY INFORMATION



THERE IS A RISK ASSUMED BY INDIVIDUALS WHO USE THIS TYPE OF EQUIPMENT. TO MINIMIZE RISK FOLLOW THESE RULES!

1. Before using, read all the warnings and instructions on the use of this machine. Use only for intended exercise. **DO NOT** modify the machine.
2. Obtain a medical exam before beginning any exercise program.
3. Keep body and clothing free of all moving objects.
4. Inspect the machine before use. **DO NOT** use it if it appears damaged. **DO NOT** attempt to fix a broken or jammed machine. Notify your authorized ParaBody dealer before use and have repairs made by an authorized service technician.
5. Be certain that weight pin is completely inserted. Use only the pin provided by the manufacturer. If unsure, call your authorized ParaBody dealer.
6. Never pin the weights or prop plate into an elevated position. **DO NOT** use the machine if found in this condition. **DO NOT** attempt to fix. Notify your authorized ParaBody dealer.
7. Inspect cables and their connections before using machine. Pay particular attention to the cable ends. **DO NOT** attempt to fix. Notify your authorized ParaBody dealer before use and have repairs made by an authorized service technician.
8. Make sure all spring loaded pull pins are fully engaged in the adjustment position and fully tighten thumbscrew before use.
9. Children must not be allowed near this machine. Supervise teenagers.

NOTE: In a continual effort to improve our products, specifications are subject to change
© 2001 Life Fitness, a division of Brunswick Corporation. All rights reserved.
ParaBody is a trademark of Brunswick Corporation

www.parabody.com

IMPORTANT NOTES

Please note:

- * Thank you for purchasing the ParaBody 220 Gym System. Please read these instructions thoroughly and keep them for future reference.
- * This product must be assembled on a flat, level surface to assure its proper function. DO NOT securely tighten any frame connections until the entire frame has been assembled, unless otherwise stated.

Tools Required for Assembly

- * Rubber mallet or hammer
- * 3/4" wrench
- * 9/16" wrench
- * Ratchet with 3/4" and 9/16" sockets
- * 5/32" Allen wrench
- * Adjustable wrench
- * Tape measure

Bolt Length Ruler

NOTE: BOLT LENGTH IS MEASURED FROM THE UNDERSIDE OF THE HEAD OF THE BOLT.

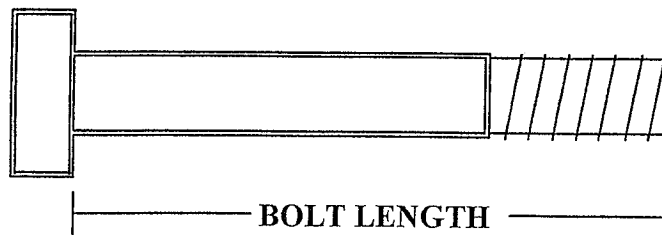

BOLT LENGTH RULER:

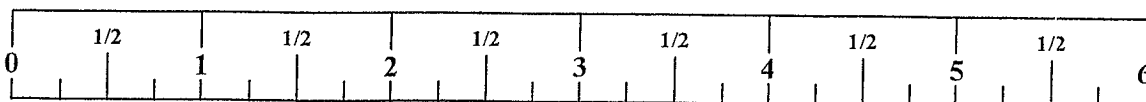

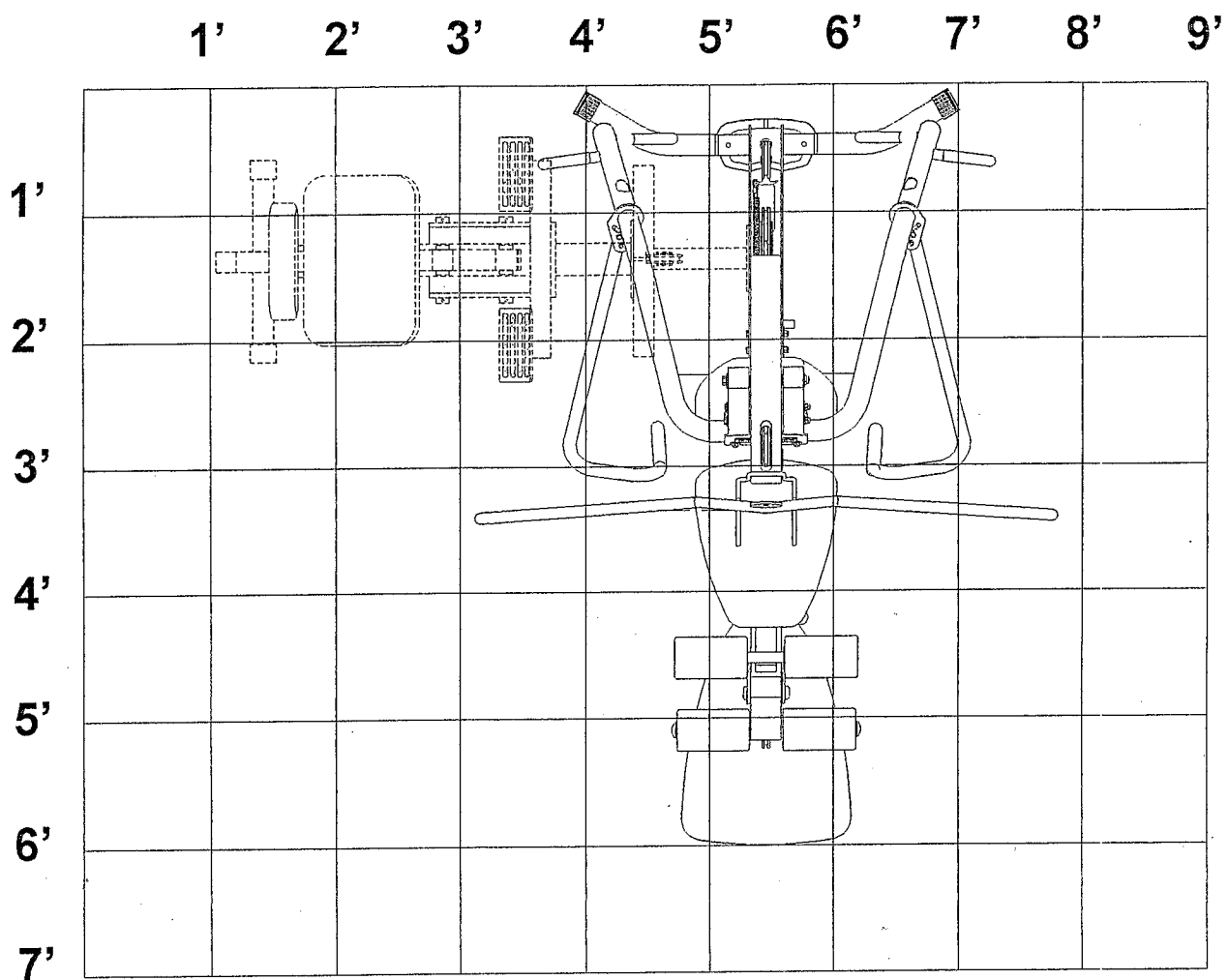

1 Square = 1' X 1'

Minimum Required Usable Space

Length = 82 inches (208.5 cm) 6' 10"
 Width = 71 inches (180.5 cm) 5' 11"
 Height = 83 inches (211 cm) 6' 11"

Dimensions Including Leg Press (optional)

Length = 82 inches (208.5 cm) 6' 10"
 Width = 108 inches (180.5 cm) 9' 0"

PARTS LIST

KEY	PART #	DESCRIPTION	QTY	KEY	PART #	DESCRIPTION	QTY
1	7005008	FRAME	1	31	3223323	3/8 X 8" BOLT	2
2	7005708	BASE	1	32	3102917	1/2 X 4" BOLT	1
3	6994608	BASE PLATE	2	33	3202104	1/2 X 8" BOLT	1
4	7005308	BOOM PLATE LEFT	1	34	3102802	3/8" LOCK NUT	25
5	7005208	BOOM PLATE RIGHT	1	35	3102804	1/2" LOW HT LOCK NUT	2
6	7005408	PRESS HANDLE RIGHT	1	36	3102501	3/8" FLAT WASHER	17
7	7005508	PRESS HANDLE LEFT	1	37	3102502	1/2" FLAT WASHER	2
8	6999708	PRESS ARM	1	38	3102503	3/4" FLAT WASHER	2
9	7005108	PRIMARY PIVOT	1	39	3108901	3/4" PLASTIC WASHER	2
10	7005808	SEAT ADJUST	1	40	6020601	1/2" FLANGE BEARING	6
11	7005608	LEG PEDESTAL	1	41	6480301	3/8 X 9/16" FLANGE SPACER	2
12	6940808	PULLEY PLATE	2	42	6480302	3/8 X 1-1/16" FLANGE SPACER	8
13	6994721	SEAT PAD	2	43	6122701	3/8 X 1" LG SPACER	6
14	6549301	3/4 X 17" TUBE	3	44	6122705	3/8 X 1-3/16" LG SPACER	4
15	6194601	4 X 7" ROLLER PAD	6	45	7012102	WEIGHT STACK SPACER	2
16	6523401	72-3/8" GUIDE ROD	2	46	3108002	WEIGHT STACK CUSHION	2
17	7006202	ERGO BAR	1	47	3110005	5/16 X 2" ROLL PIN ASSEMBLY	2
18	7015701	WEIGHT STACK SHAFT	1	48	3103302	SHAFT COLLAR	2
19	6953702	HEAD PLATE	1	49	6996901	3/8" LOCKING SPRING PIN	2
20	7014101	LAT CABLE	1	50	6412001	3/8" SPRING PIN	1
21	7014201	LOW CABLE	1	51	6972201	WEIGHT SELECTOR PIN	1
22	6939202	WEIGHT PLATE	15	52	6145801	3-PRONG KNOB	1
23	6382301	WEIGHT PLATE BUSHING 10 CT	3	53	6595101	ADJUSTABLE GLIDE	1
24	3116201	3-1/2" PULLEY	12	54	3105401	STARLOCK COLLAR	6
25	6409101	ANKLE STRAP	1	55	6866601	RH CAP	2
26	6075906	CHAIN	1	56	6866801	1/2" RHCAP HOLDER WASHER	2
27	3102924	3/8 X 1-3/4" BOLT	2	57	3103801	SNAP LINK	2
28	3102922	3/8 X 2-3/4" BOLT	4	58	6416601	PARAGLIDES (QTY 8)	1
29	3102904	3/8 X 3" BOLT	4	60	3221702	E - RING	1
30	3102905	3/8 X 3-3/4" BOLT	15	61	6978101	WEIGHT STACK LABEL	1
				62	7071802	FOOTPLATE	1

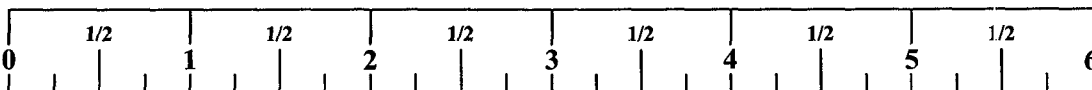

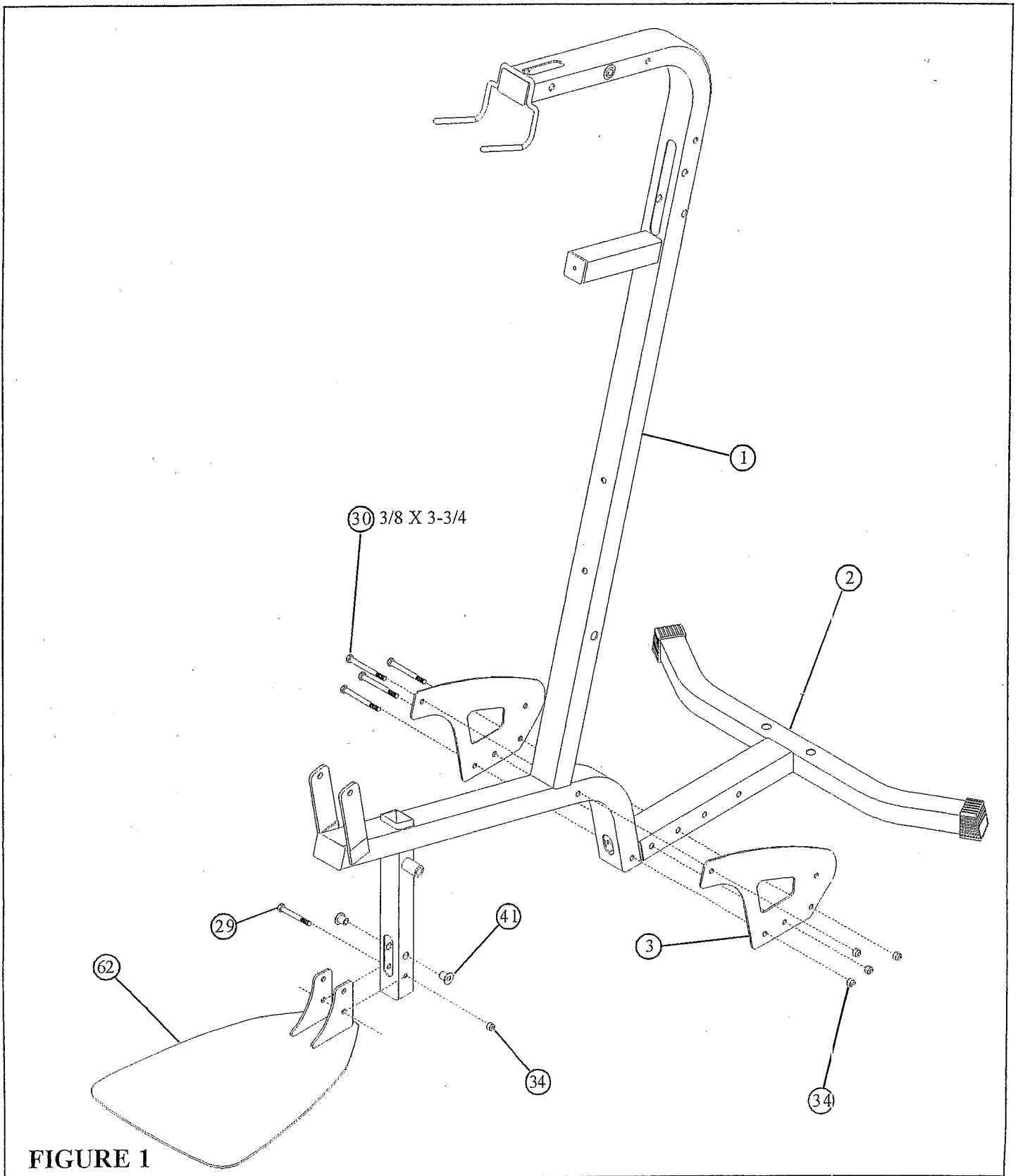

FIGURE 1

STEP 1:

- **LOOSELY** assemble two BASE PLATES (3) to the FRAME (1) and BASE (2) using four 3/8 X 3-3/4" BOLTS (30) and four 3/8" LOCK NUTS (34). See FIGURE 1.
- Insert two 3/8 x 9/16" FLANGE SPACERS (21) into the upper holes in the FRAME (1) as shown in figure 1
- **LOOSELY** assemble the FOOTPLATE (62) to the lower holes in the FRAME (1) using one 3/8 x 3" BOLT (29) and one 3/8 LOCKNUT (34)

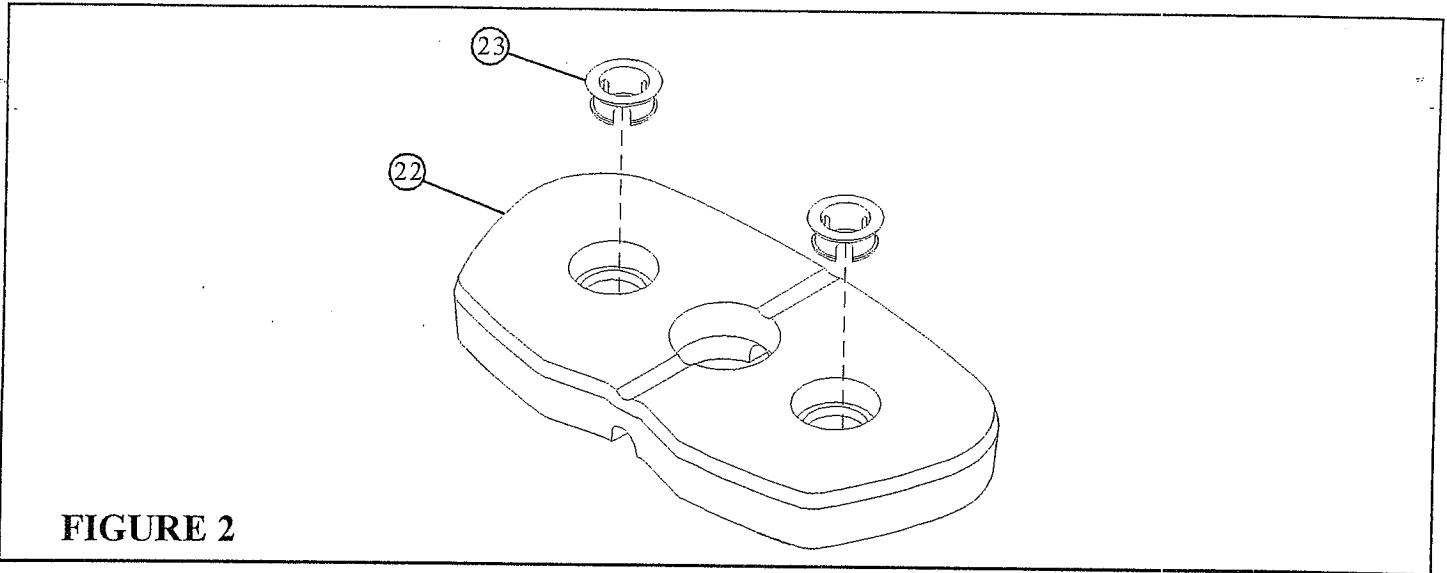

FIGURE 2

STEP 2:

- Insert two WEIGHT PLATE BUSHINGS (23) into each of the fifteen WEIGHT PLATES (22) as shown in FIGURE 2.

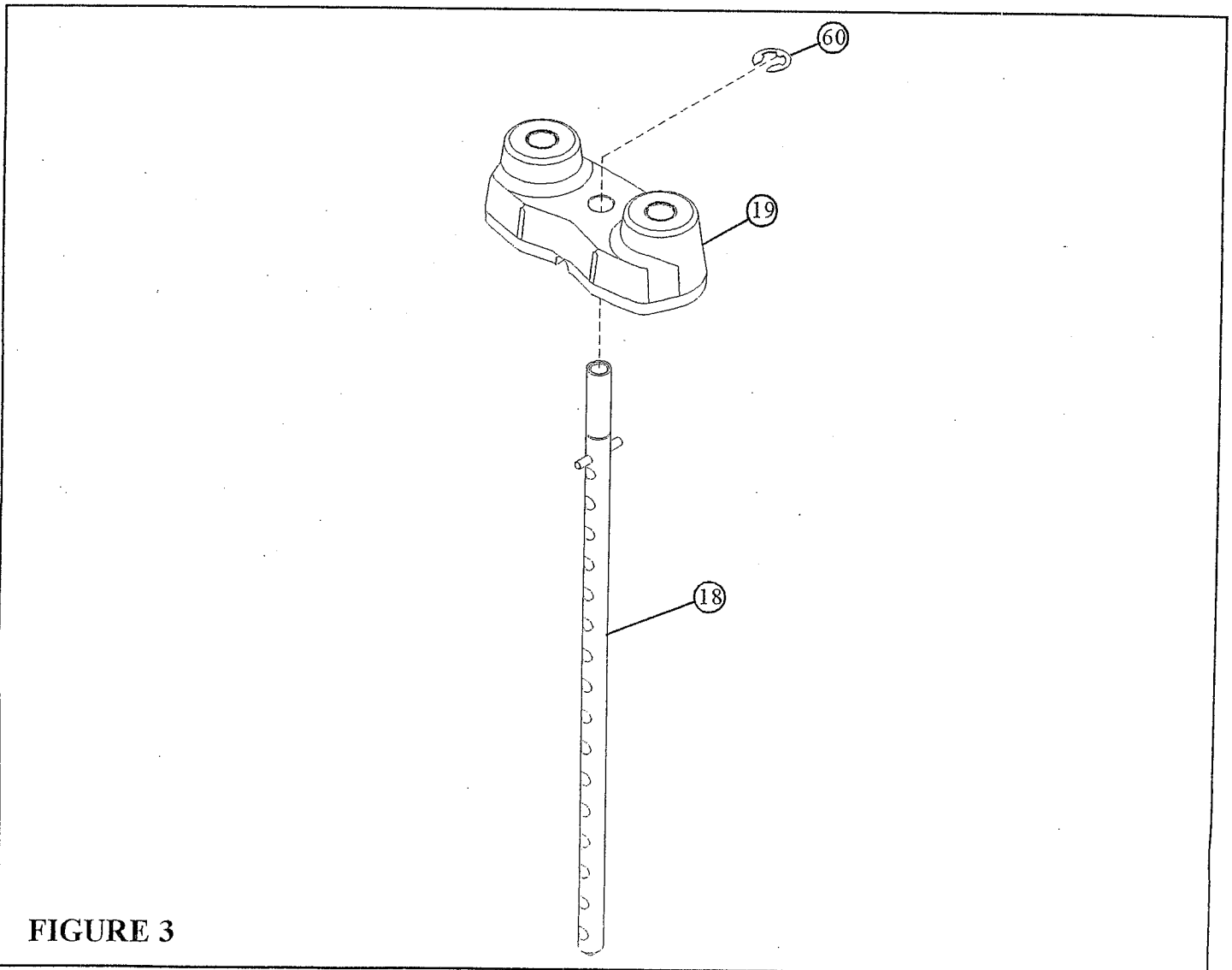

FIGURE 3

STEP 3:

- Slide the WEIGHT PLATE SHAFT (18) thru the hole in the HEAD PLATE (19), and lock in place using one E-RING (60) as shown in FIGURE 3.



STEP 4:

- Insert two GUIDE RODS (16) into the BASE (2) as shown on FIGURE 4. (NOTE: Lubricate GUIDE RODS (16) with silicon or teflon spray available at most hardware stores.)
- Slide the following items in order down each GUIDE ROD (16), one WEIGHT STACK SPACER (45), one 3/4" FLAT WASHER (38) and one WEIGHT STACK CUSHION (46)
- Using **EXTREME CARE** slide all fifteen WEIGHT PLATES (22) down the GUIDE RODS (16) onto the WEIGHT STACK CUSHIONS (46). Make sure that the keyholes of the WEIGHT PLATES (22) are all facing the right way.
- Slide the head plate assembly down GUIDE RODS (16) onto the weight stack.
- Slide one SHAFT COLLAR (48) down each GUIDE ROD (16).

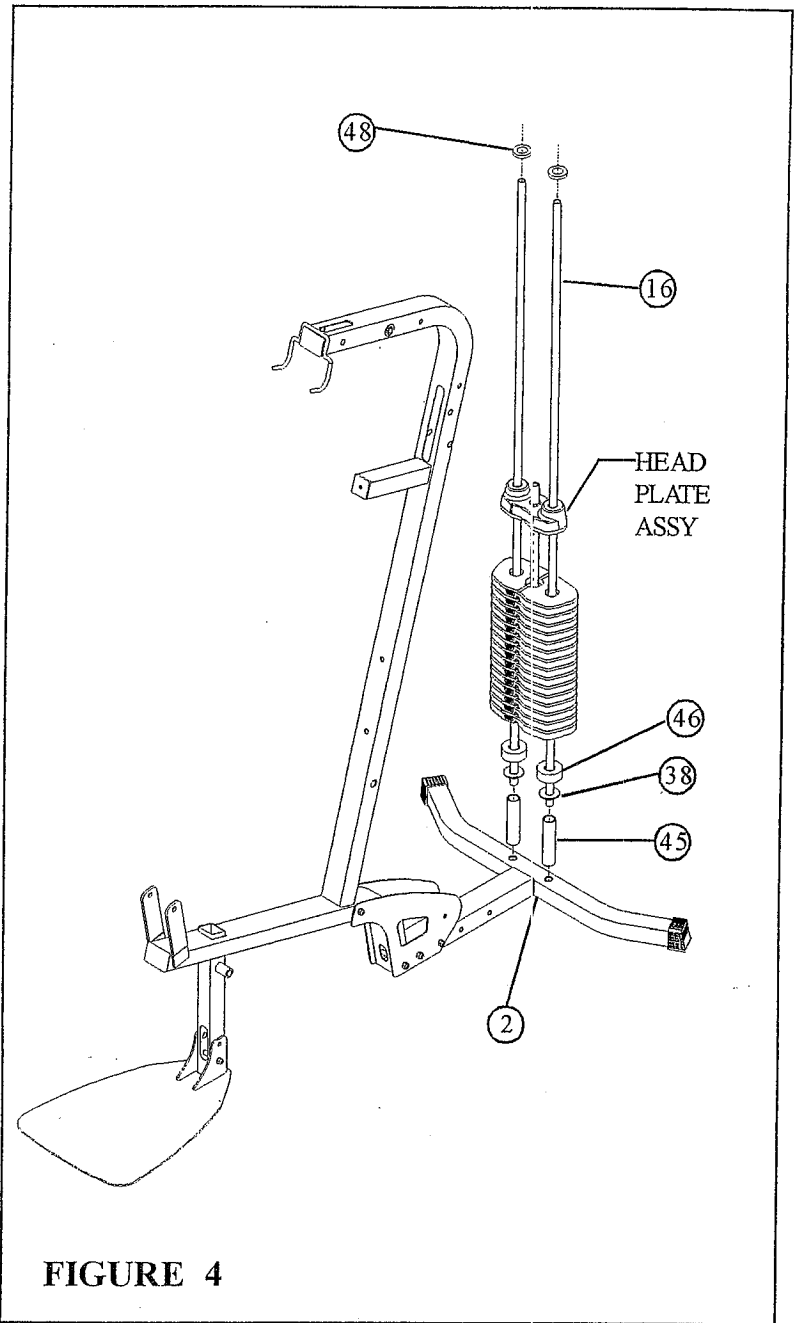

FIGURE 4

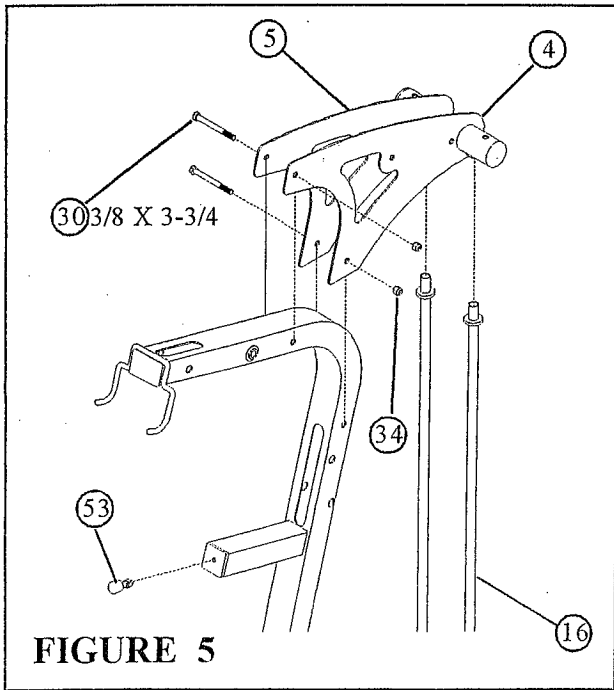

FIGURE 5

STEP 5:



- Carefully slide the RIGHT (5) and LEFT (4) BOOM PLATES onto the GUIDE RODS (16) as shown in FIGURE 5 and loosely assembly BOOM PLATES (5), (4) to frame (1) using two 3/8 x 3-3/4" BOLTS (30) and two 3/8" LOCK NUT (34) [CAUTION MUST BE TAKEN NOT TO PULL GUIDE RODS (16) OUT OF BASE (2)]
- Screw ADJUSTABLE GLIDE (53) approximately 1/2" into FRAME (1) and tighten jam nut securely as shown

FIGURE 6

STEP 6:

- Insert two 1/2" FLANGE BEARINGS (40) into the LEFT PRESS HANDLE (7) as shown in FIGURE 6
- Using hammer tap one 5/16 X 2" ROLL PIN (47) thru LEFT PRESS HANDLE (7) until it is flush with other side of HANDLE as shown in FIGURE 6
- Repeat STEP 6 for the RIGHT PRESS ARM HANDLE (6)

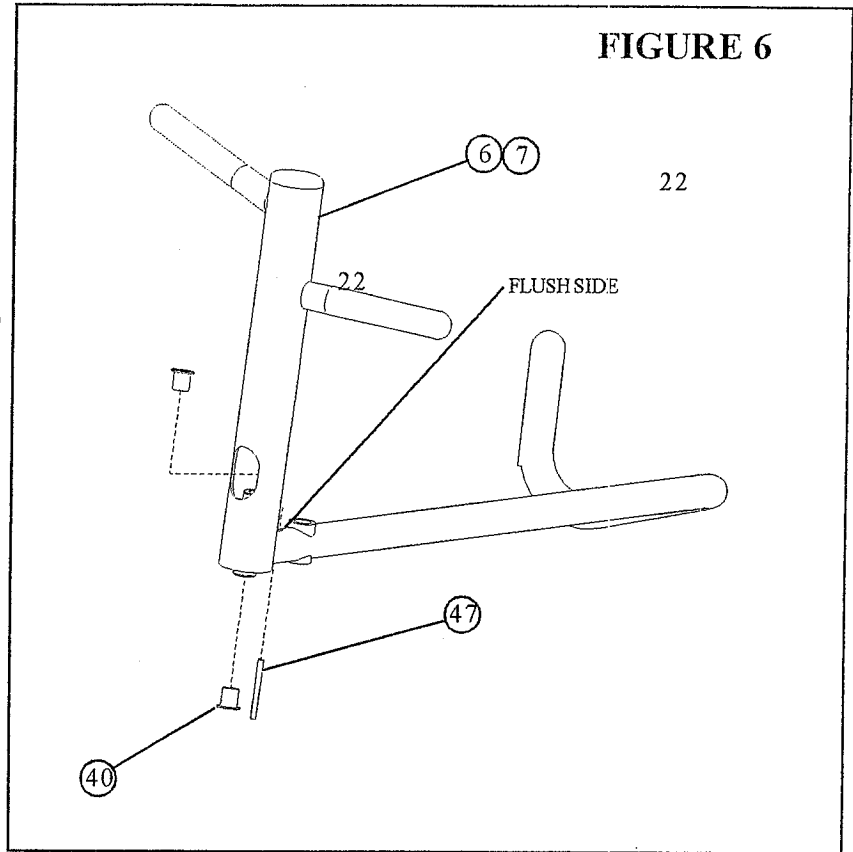

STEP 7:

- Place LEFT PRESS HANDLE (7) onto PRESS ARM (8). Make sure that the 5/16 X 2" ROLL PIN (47) passes into the slot located in the plate of the PRESS ARM (8)
- Once in place secure and tighten the LEFT PRESS HANDLE (7) to PRESS ARM (8) using one 3/8" WASHER (36) and one 3/8" LOCK NUT (34)
- IMPORTANT! Do not overtighten: PRESS ARM should rotate freely
- Repeat STEP 7 for the RIGHT PRESS ARM HANDLE (6)

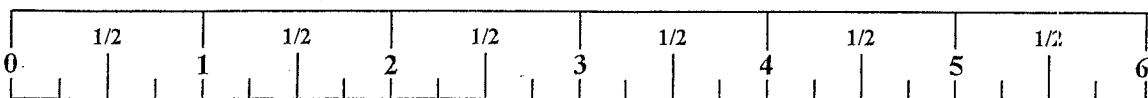
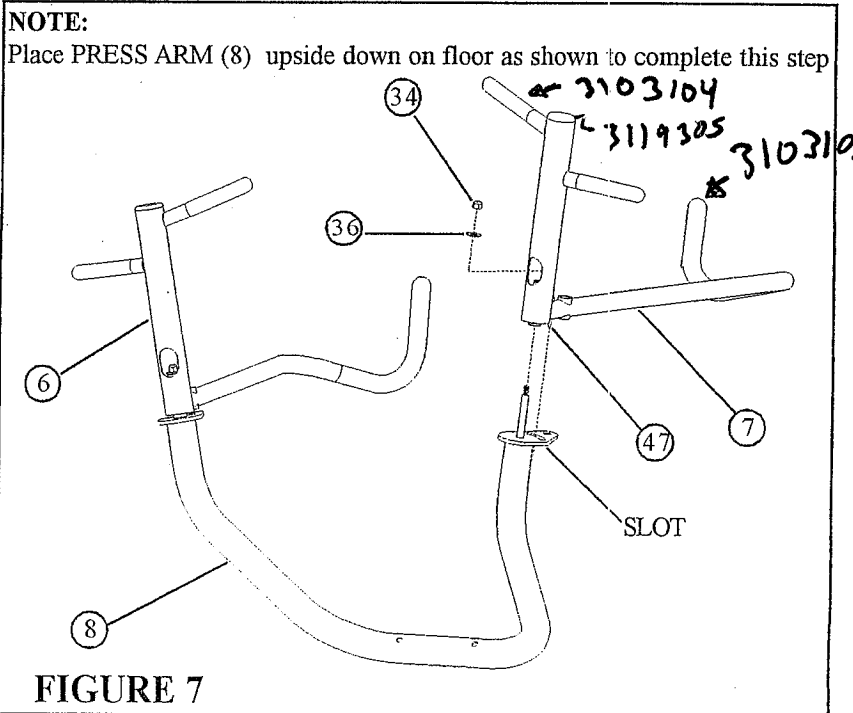

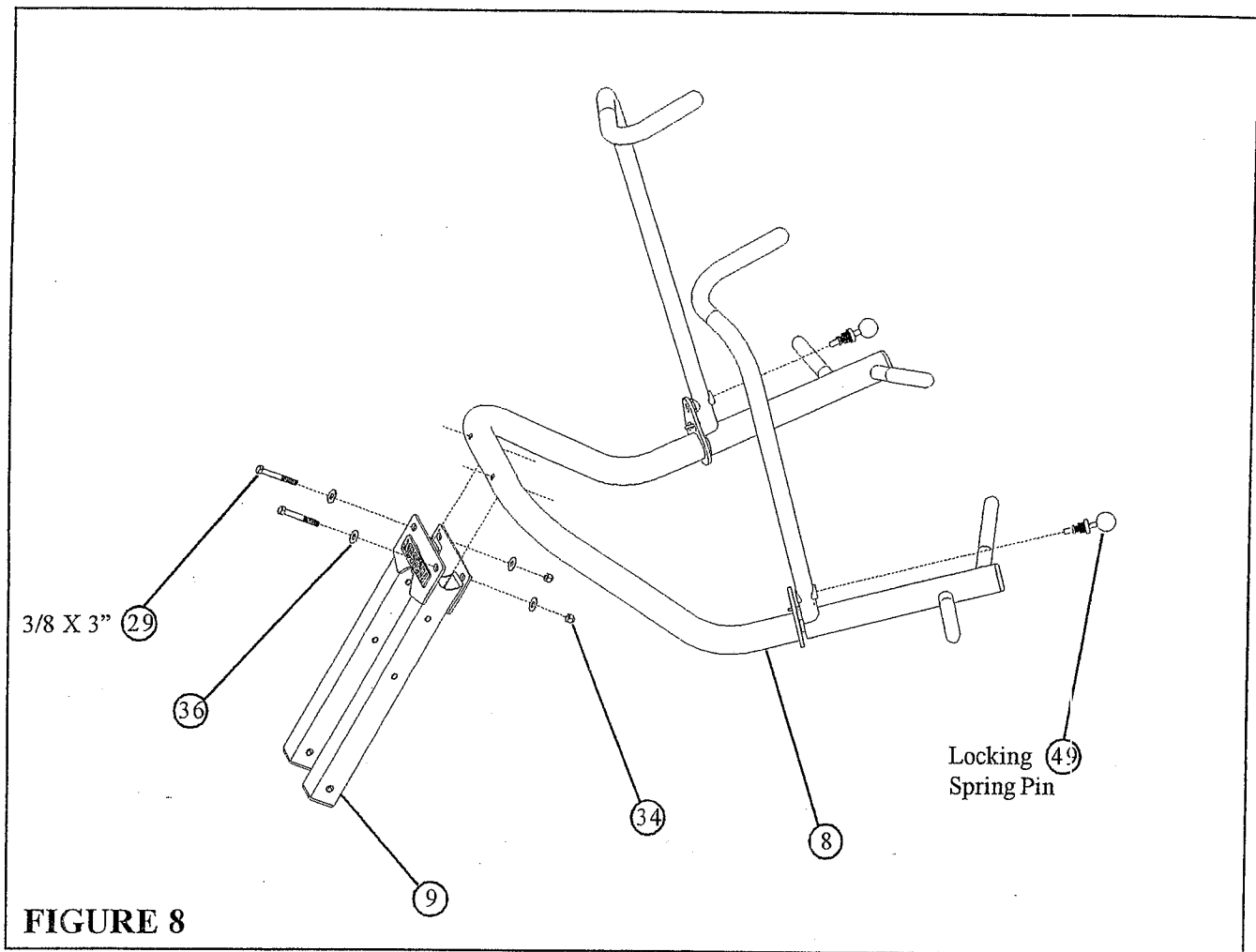

STEP 8:

- Place PRESS ARM (8) into PRIMARY PIVOT (9) and securely tighten using two 3/8 X 3" BOLTS (29), four 3/8" FLAT WASHERS (36) two 3/8" LOCK NUTS (34)
- Insert and tighten two 3/8" LOCKING SPRING PINS (49) into PRESS HANDLES (6), (7).
- Lock PRESS ARMS (6), (7) into place using 3/8" LOCKING SPRING PINS (49)
- To disengage LOCKING SPRING PINS (49), pull out and twist 1/4 turn.

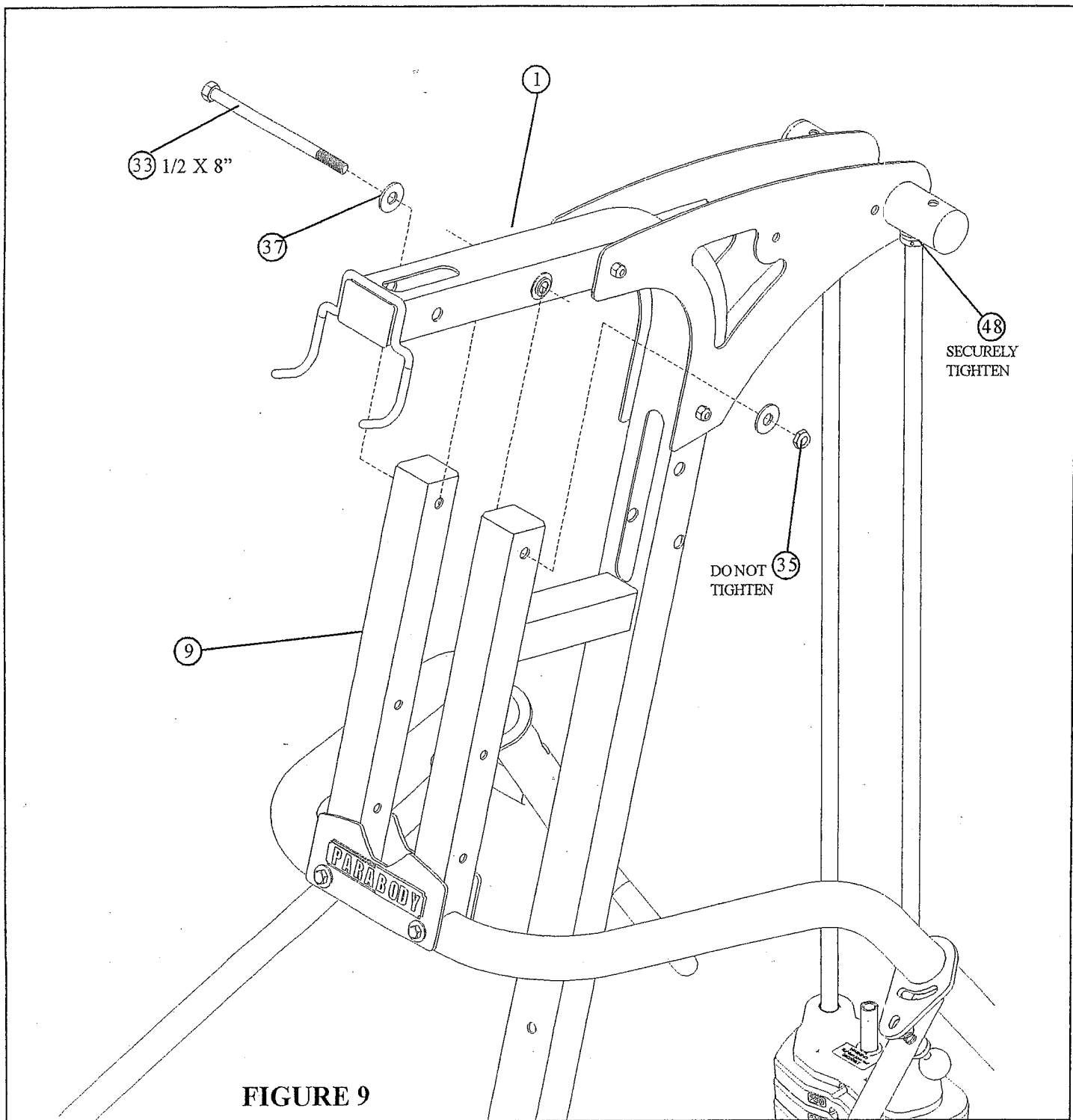
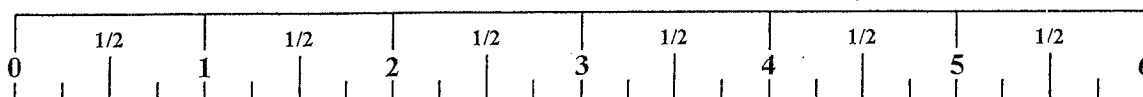

FIGURE 9

STEP 9

- **SECURELY TIGHTEN ALL FRAME CONNECTION BEFORE PROCEEDING TO NEXT STEP**
- **SECURELY TIGHTEN** top of both SHAFT COLLARS (48) flush to bottom of both BOOM PLATES (4),(5)
- Assemble the PRIMARY PIVOT (9) of the PRESS ARM ASSEMBLY to the top of the FRAME (1) using 1/2 X 8" BOLT (33), two 1/2" FLAT WASHERS (37) and 1/2" LOW HT LOCK NUT (35). **IMPORTANT! DO NOT TIGHTEN YET**



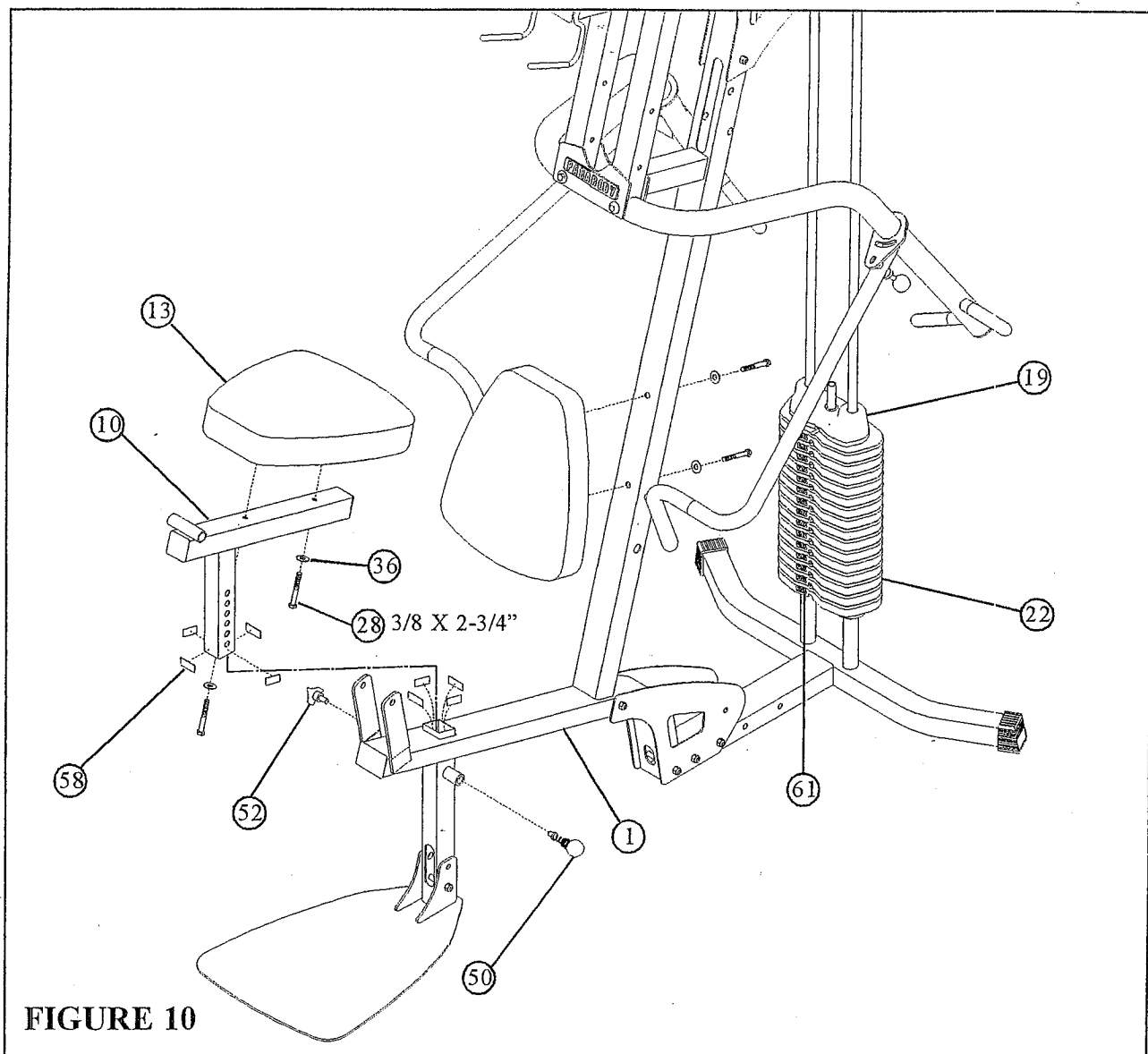

FIGURE 10

STEP 10:

- Apply WEIGHT STACK LABELS (61) to WEIGHTS (22) and HEAD PLATE (19) as shown in FIGURE 10. Begin with number one at the HEAD PLATE (19) with larger numbers in consecutive order towards bottom of weight stack.
- Apply four PARAGLIDES (58) to the **INSIDE** of the tube of FRAME (1) as shown. Apply the remaining four PARAGLIDES (58) to the **OUTSIDE** and **FLUSH TO BOTTOM** of tube located on SEAT ADJUSTMENT (10)
- Securely assemble one SEAT PAD (13) to the SEAT ADJUSTMENT (10) using two 3/8 X 2-3/4" BOLTS (28) and two 3/8" WASHERS (36) as shown.
- Securely assemble one SEAT PAD (13) to the FRAME (1) using two 3/8 X 2-3/4" BOLTS (28) and two 3/8" WASHERS (36) as shown.
- Gently insert SEAT ADJUSTMENT (10) into tube located on FRAME (1)
DO NOT FORCE THE SEAT ADJUSTMENT IN. THIS MAY CAUSE THE PARAGLIDES TO TEAR.
- Securely tighten the SPRING PIN (50) to the FRAME (1) and hand tighten the THREE PRONG KNOB (52)

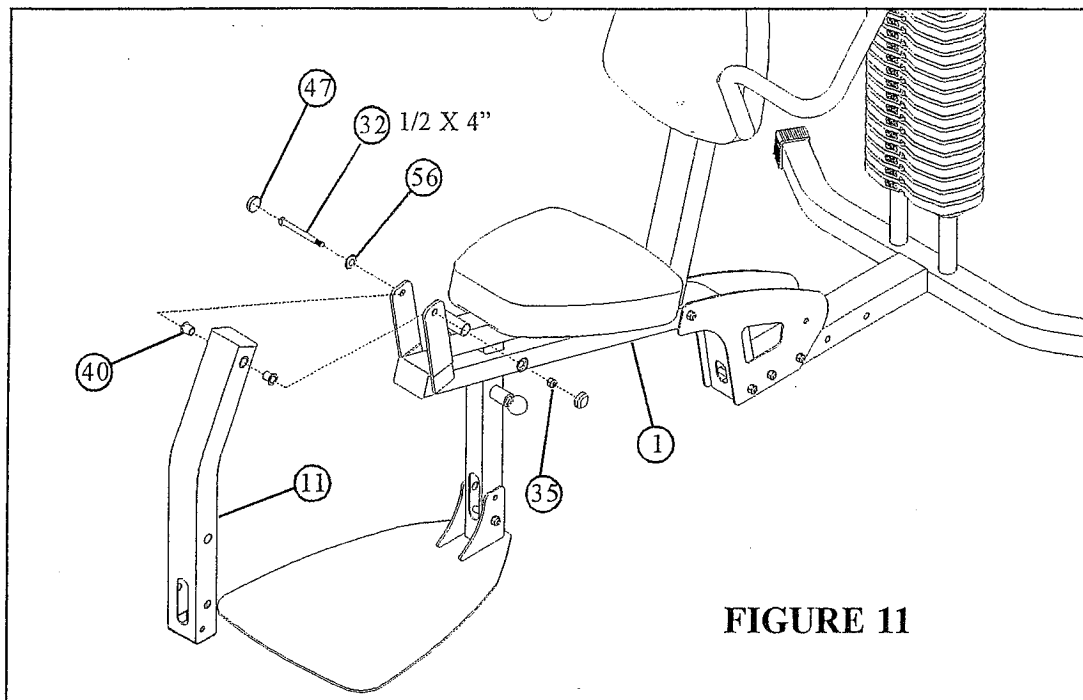

FIGURE 11

STEP 11:

- Insert two 1/2" FLANGE BEARINGS (40) into LEG PEDESTAL (11) as shown.
- Assemble the LEG PEDESTAL (11) to the FRAME (1) using one 1/2 X 4" BOLT (32), two RH WASHERS (56) and one 1/2" LOW HT LOCK NUT (35)
- Assemble two RH CAPS (47) to the 1/2" RH WASHERS (56) as shown in FIGURE 11

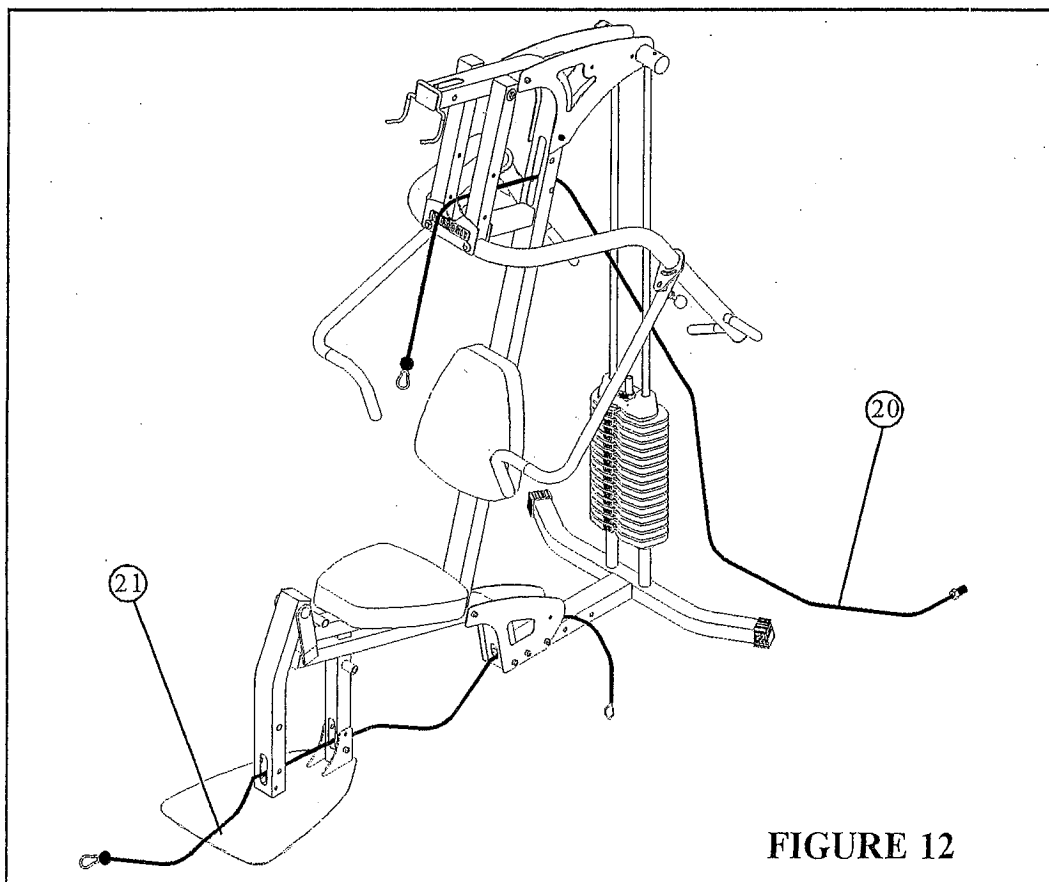
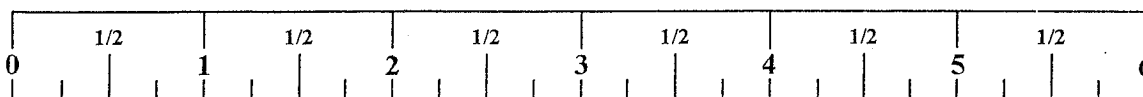

FIGURE 12

STEP 12:

- Route LAT CABLE (20) and LOW CABLE (21) as shown in FIGURE 12



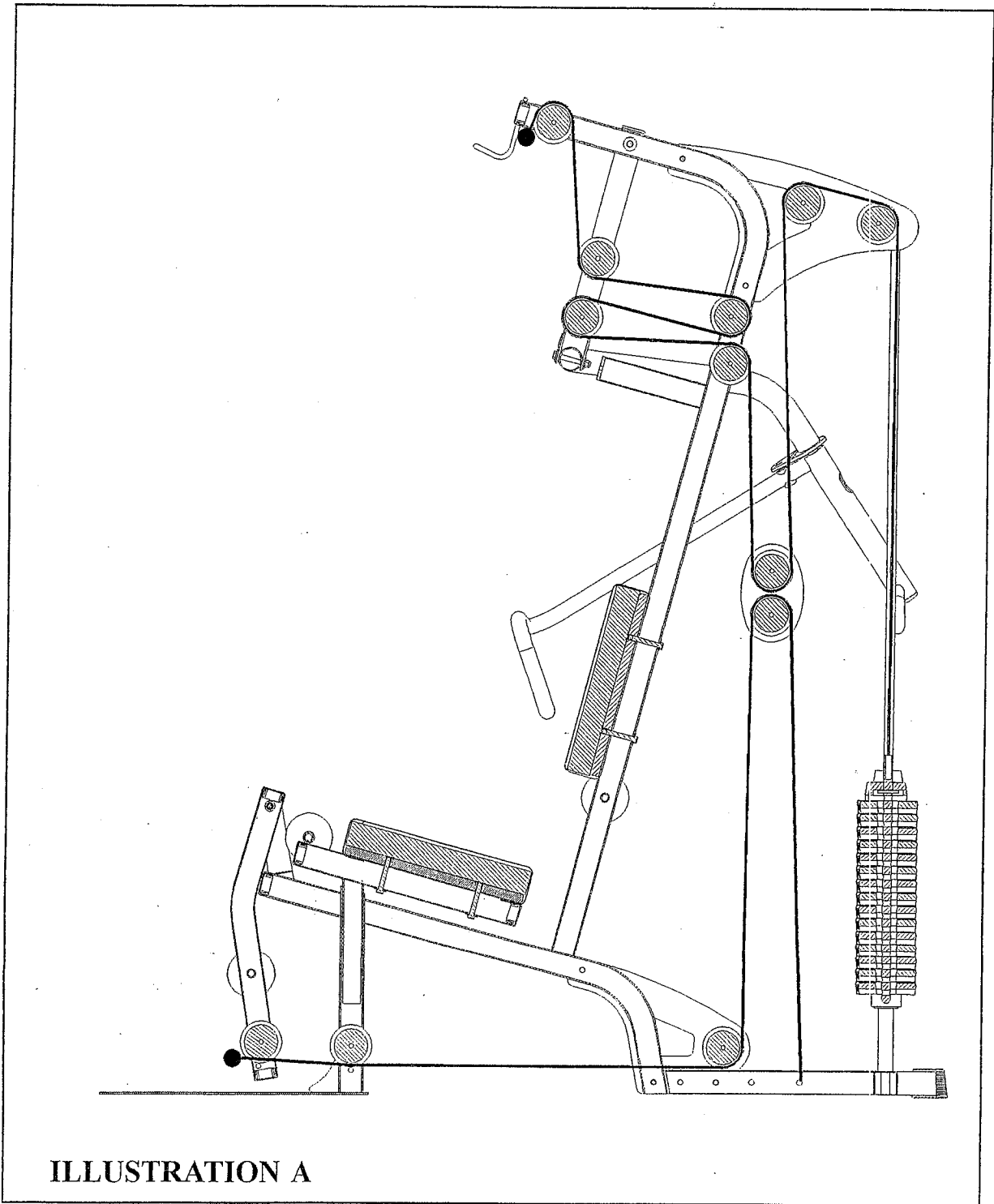

ILLUSTRATION A

- ILLUSTRATION "A" used as cable routing reference for steps 13-16

NOTE: IF YOU PURCHASED A LEG PRESS, PLEASE REFER TO THE CABLE ROUTING INSTRUCTIONS INCLUDED WITH THE LEG PRESS KIT

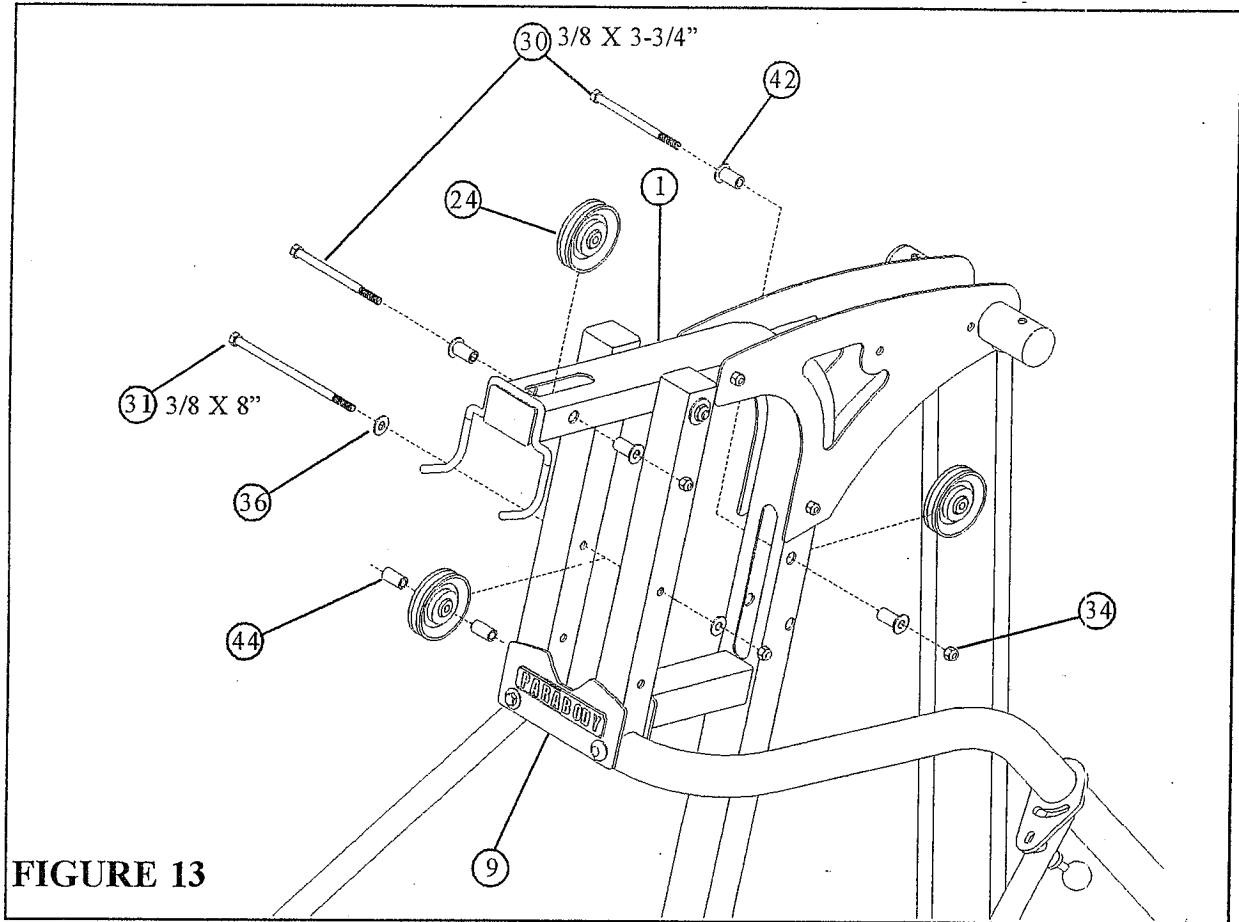
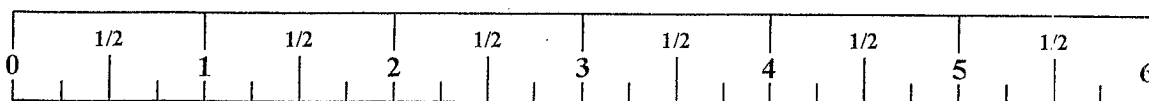

FIGURE 13

STEP 13:

- Refer to cable ILLUSTRATION "A" on page 11 for cable routing while installing pulleys.
- Assemble two 3-1/2" PULLEYS (24) into FRAME (1) using two 3/8 X 3-3/4" BOLTS (30), four 3/8 X 1-1/16" FLANGE SPACERS (42) and two 3/8" LOCK NUTS (34) and tighten securely.
- Assemble one 3-1/2" PULLEY (24) into PRIMARY PIVOT (9) upper hole using one 3/8 X 8" BOLT (31), two 3/8" FLAT WASHERS (36), two 3/8 X 1-3/16" SPACERS (44) and one 3/8" LOCK NUT (34) and tighten securely



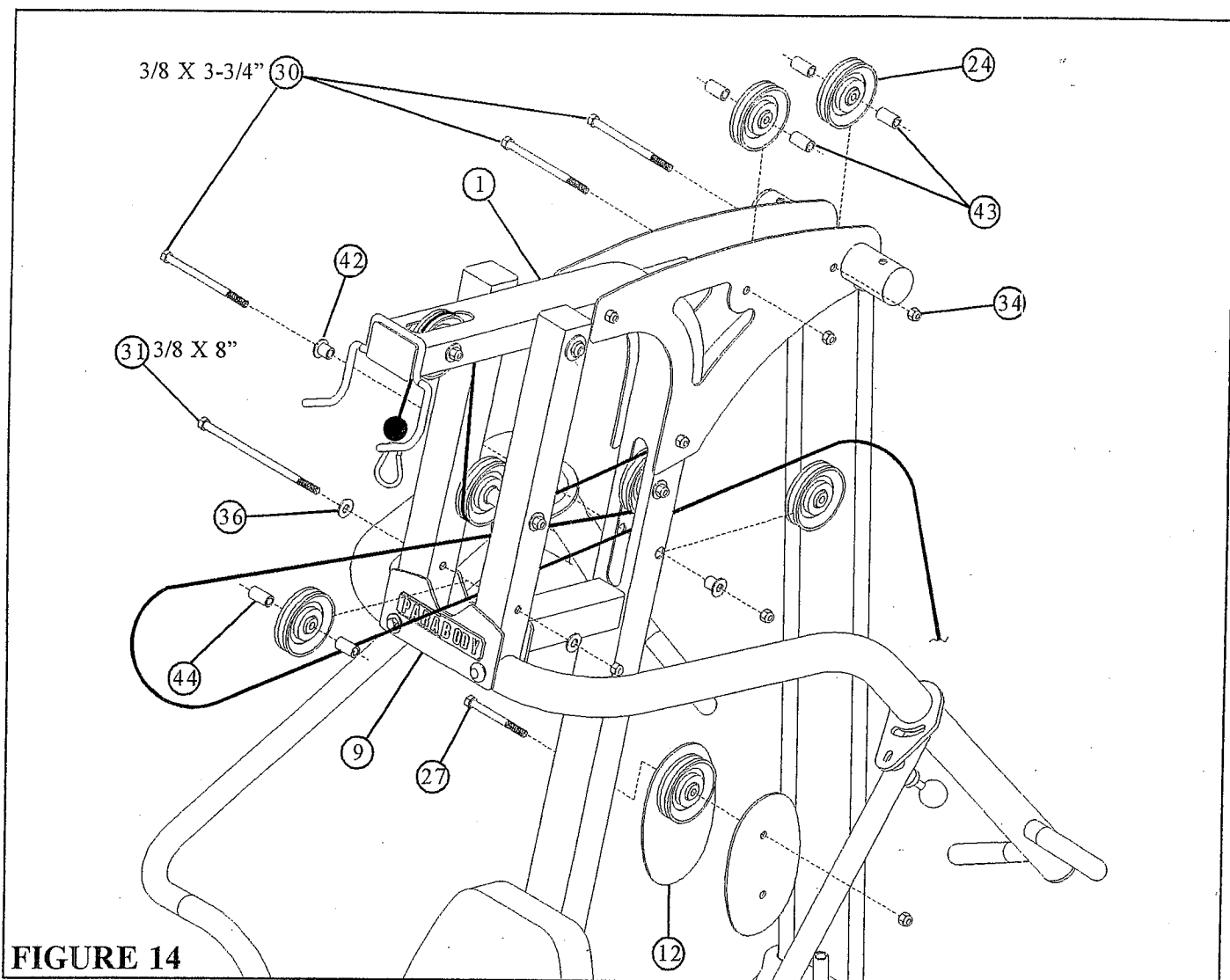
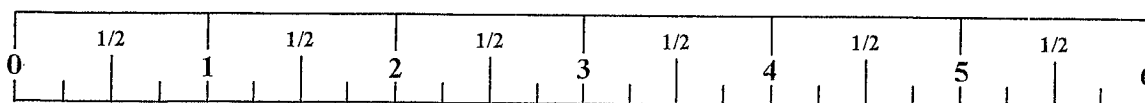

FIGURE 14

STEP 14:

- Refer to cable ILLUSTRATION "A" on page 11 for cable routing while installing pulleys.
- Assemble one 3-1/2" PULLEY (24) into the PRIMARY PIVOT (9) lower hole using one 3/8 X 8" BOLT (31), two 3/8" FLAT WASHERS (36), two 3/8 X 1-3/16" SPACERS (44) and one 3/8" LOCK NUT (34) and tighten securely.
- Assemble one 3-1/2" PULLEY (24) to the FRAME (1) using one 3/8 X 3-3/4" BOLT (30), two 3/8 X 1-1/16" FLANGE SPACERS (42), one 3/8" LOCK NUT (34) and tighten securely
- Loosely assemble one 3-1/2" PULLEY (24) between PULLEY PLATES (12) using one 3/8 X 1-3/4" BOLT (27) and one 3/8" LOCK NUT (34).
- Assemble two 3-1/2" PULLEYS (24) between the left and right BOOM PLATES (4) and (5) using two 3/8 X 3-3/4" BOLTS (30), four 3/8 X 1" SPACERS (43) and two 3/8" LOCK NUTS (34)



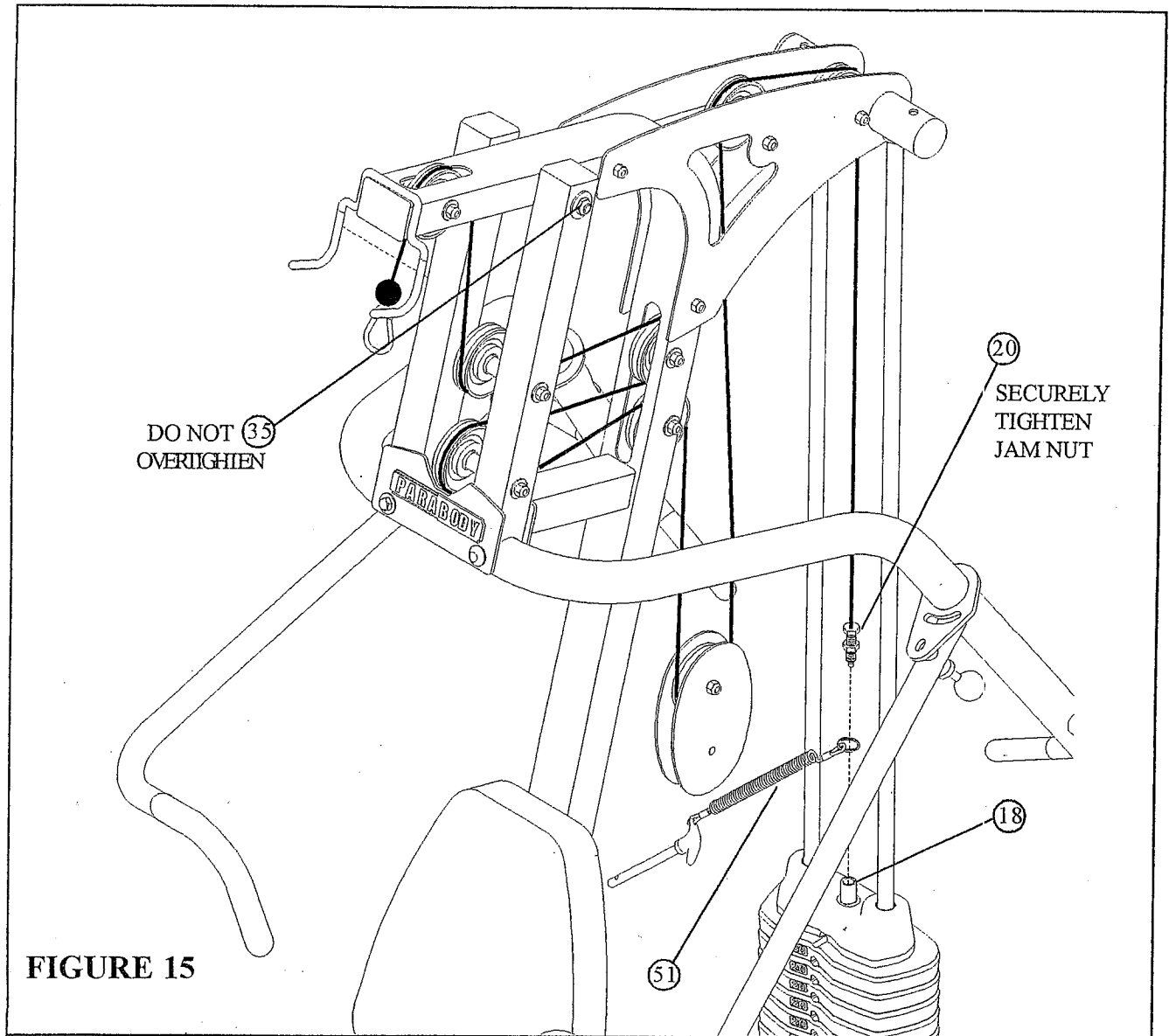
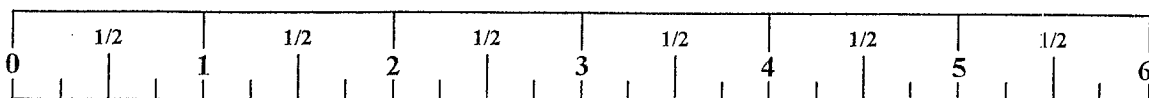
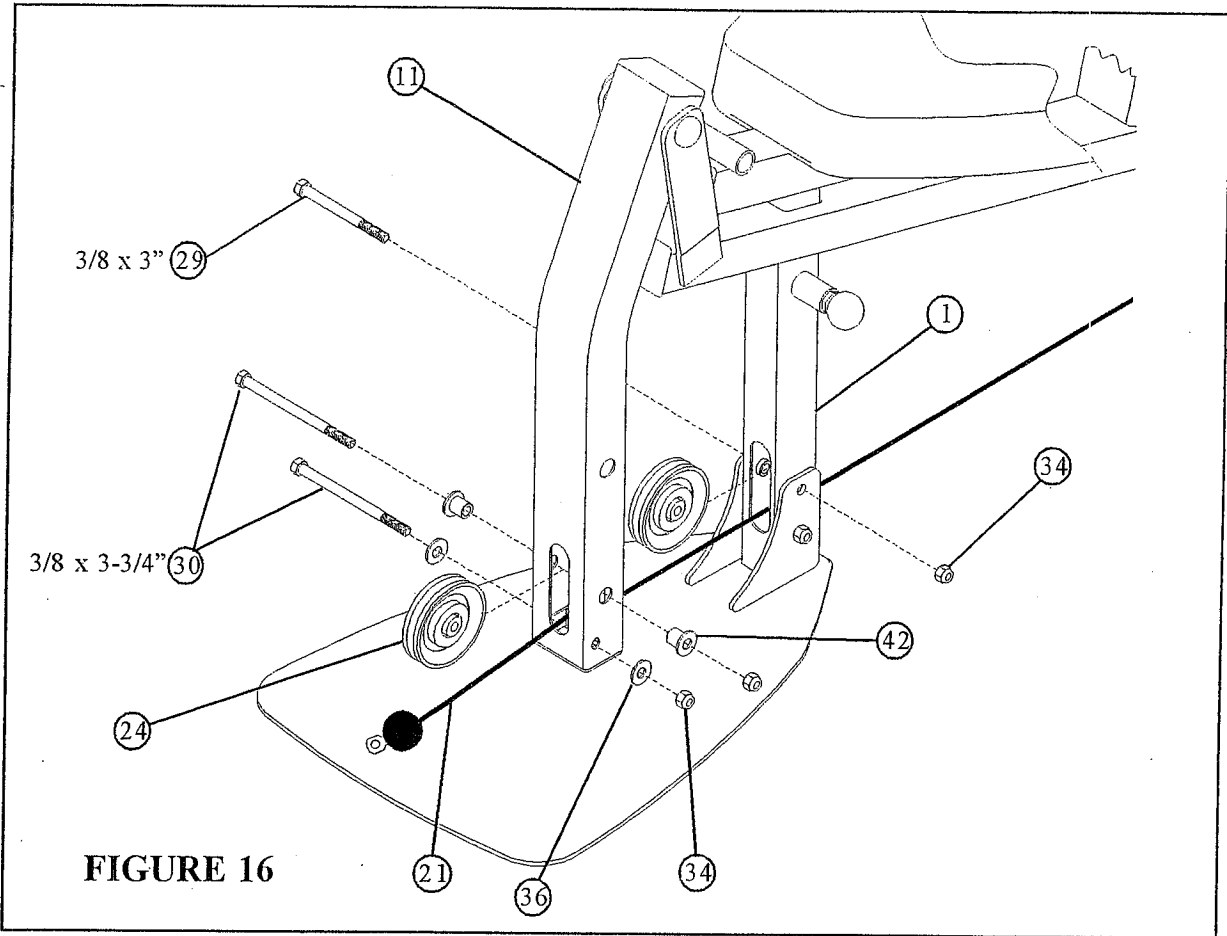

FIGURE 15

STEP 15

- Slip ring of WEIGHT SELECTOR PIN (51) down WEIGHT STACK SHAFT (18) and insert pin into one of the weights
- Screw end of LAT CABLE (20) into top of PLATE SHAFT (18) and securely tighten JAM NUT as shown in FIGURE 15
- Securely tighten 1/2" LOCK NUT (55) on PRIMARY PIVOT of PRESS ARM (9).
IMPORTANT! DO NOT OVERTIGHTEN: PRESS ARM SHOULD ROTATE FREELY.





STEP 16:

- Refer to cable ILLUSTRATION "A" on page 11 for cable routing while installing pulleys.
- [CABLE MUST BE POSITIONED BETWEEN PULLEY AND LOWER BOLT ASSEMBLY ON LEG PEDESTAL (11) AND FRAME (1)]
- Securely assemble the ball end of the LOW CABLE (21) and one 3-1/2" PULLEY (24) to the LEG PEDESTAL (11) using two 3/8 X 3-3/4" BOLTS (30), two 3/8" X 1-1/16" FLANGE SPACERS (42), two 3/8" WASHERS (64), and two 3/8" LOCKNUTS (34). (NOTE: The LEG CABLE (91) should be routed over the retaining bolt as shown in FIGURE 16.)
- Securely assemble one 3-1/2" PULLEY (24) to the FRAME (1) using one 3/8 X 3" BOLTS (29), and one 3/8" LOCKNUT (63). (NOTE: The LEG CABLE (91) should be routed over the retaining bolt as shown in FIGURE 16.)

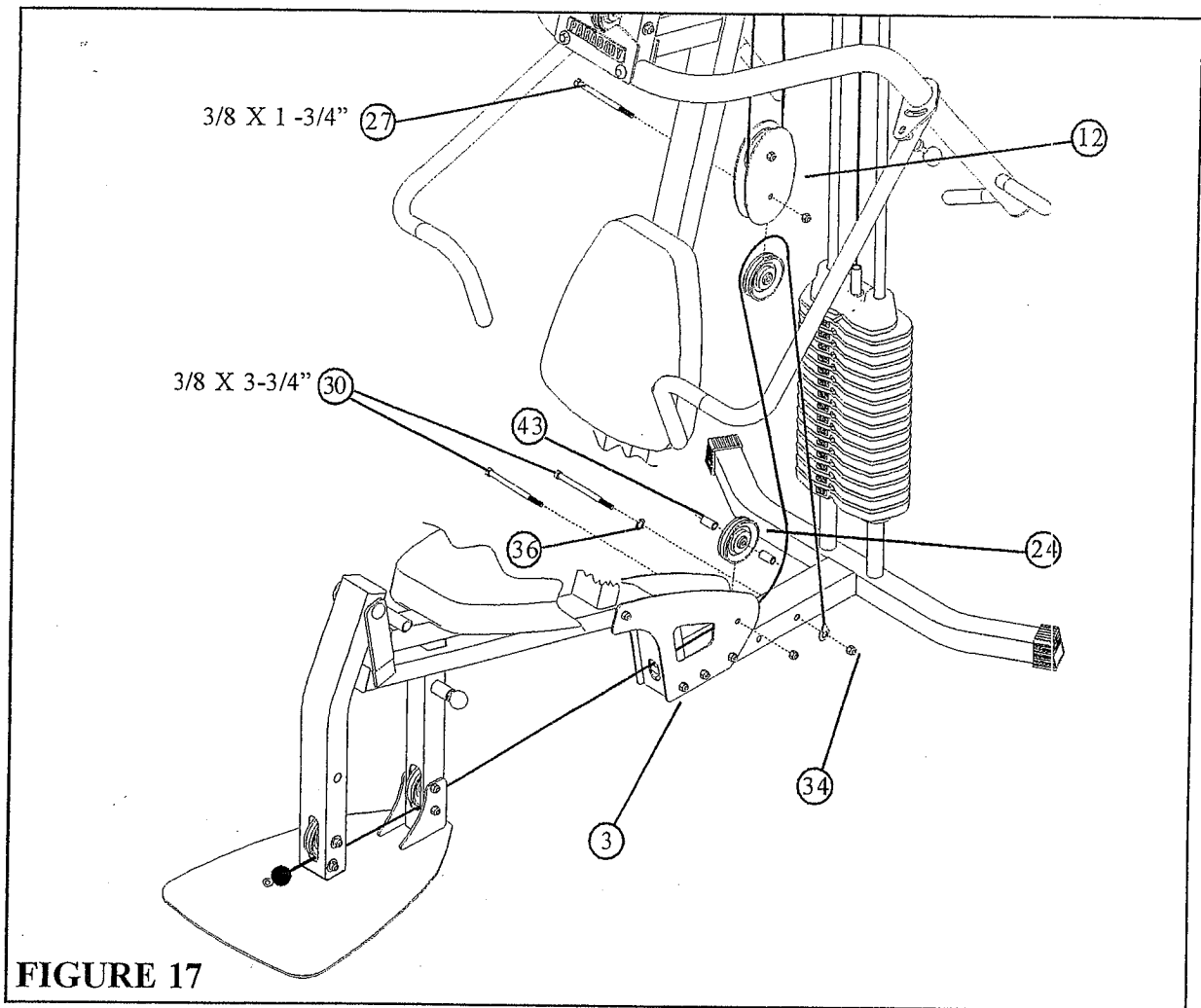
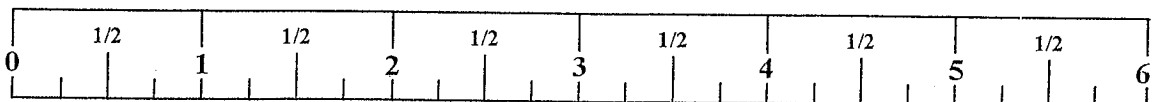

FIGURE 17

STEP 17:

- Refer to cable **ILLUSTRATION "A"** on page 11 for cable routing while installing pulleys.
- Assemble one 3-1/2" **PULLEY (24)** between **BASE PLATES (3)** using one 3/8 X 3-3/4" **BOLT (30)**, two 3/8 X 1" **SPACERS (43)**, one 3/8" **LOCK NUT (34)** and tighten securely.
- Loosely assemble one 3-1/2" **PULLEY (24)** between the **PULLEY PLATES (12)** using one 3/8 X 1-3/4" **BOLT (27)**, and one 3/8" **LOCK NUT (34)**.
- Secure end of **LOW CABLE (21)** using one 3/8 x 3-3/4 **BOLT (30)**, one 3/8" **FLAT WASHER (36)** one 3/8" **LOCK NUT (34)** as shown in **FIGURE 17**
- Tighten both 3-1/2" **PULLEYS (24)** located on **PULLEY PLATES (12)**



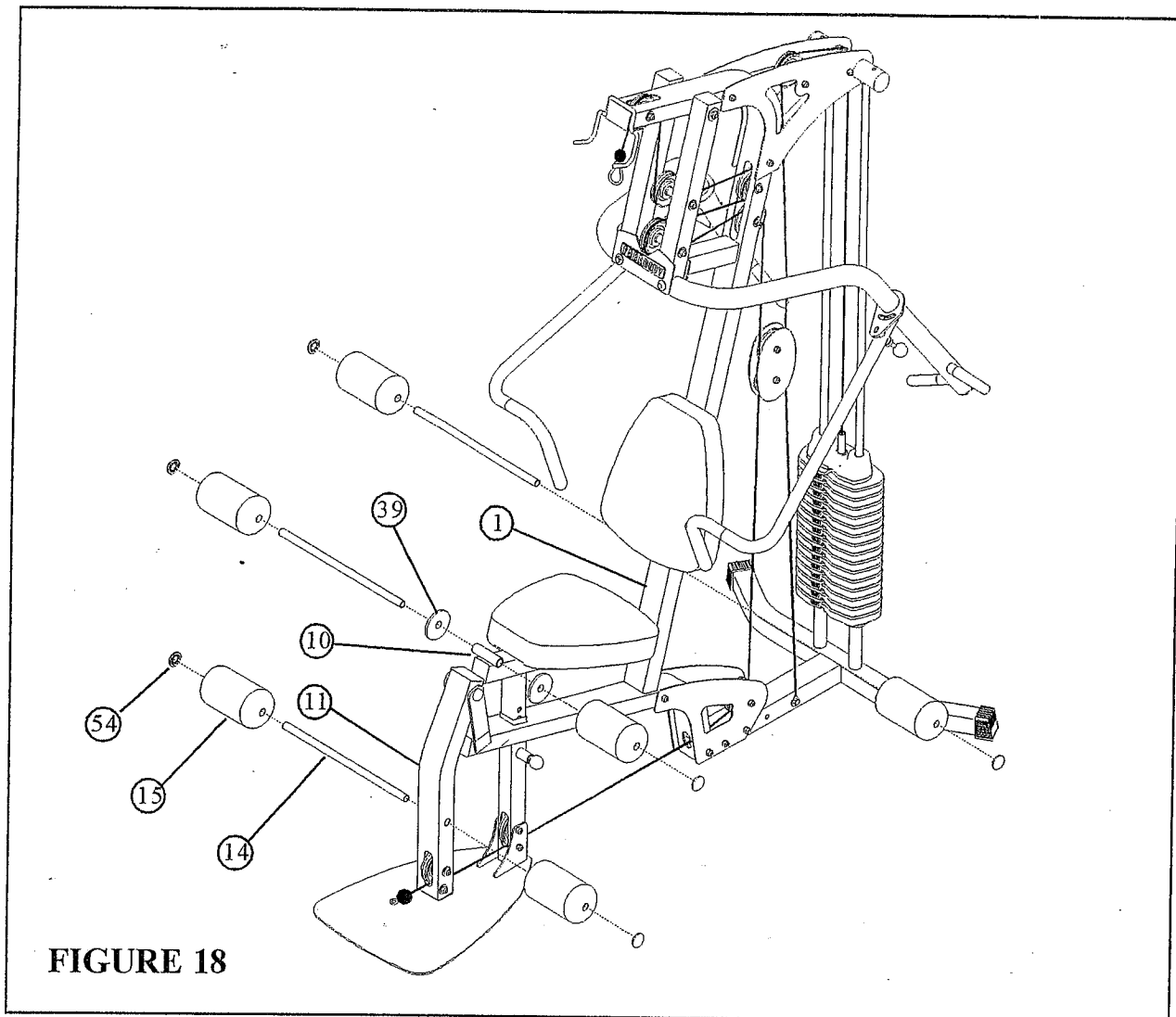
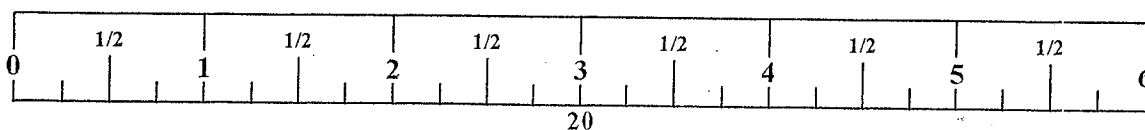

FIGURE 18

STEP 18:

- Attach two 4 X 7" ROLLER PADS (15) to the LEG PEDESTAL (11) using one 3/4 X 17" TUBE (14) and two 3/4" STARLOCK COLLARS (54) as shown in FIGURE 18.
- Attach two 4 X 7" ROLLER PADS (15) to the SEAT ADJUST (10) using one 3/4 X 1" TUBE (14), two PLASTIC WASHERS (39) and two 3/4" STARLOCK COLLARS (54) as shown in FIGURE 18.
- Attach two 4 X 7" ROLLER PADS (15) to the FRAME (1) using one 3/4 X 17" TUBE (14) and two 3/4" STARLOCK COLLARS (52) as shown in FIGURE 18.



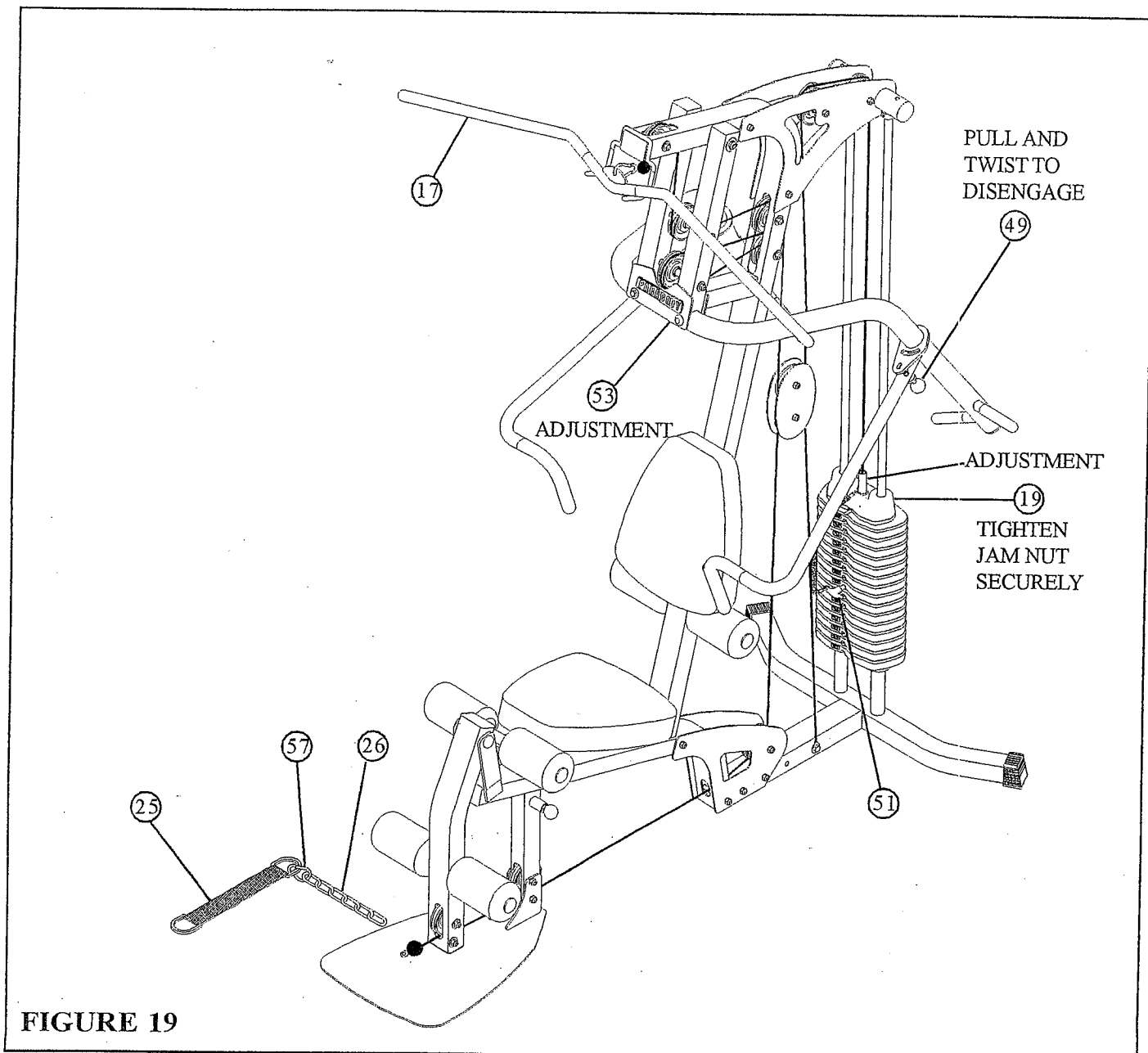

FIGURE 19

STEP 19:

- If upon completion of assembly, the HEAD PLATE (19) does not sit on top of the first WEIGHT PLATE (22), push the HEAD PLATE (19) down, insert the WEIGHT SELECTOR PIN (51) and perform several repetitions at the press station. This will relax the cable system and prevent the HEAD PLATE (19) from lifting up. See FIGURE 19
- If after completing previous step, the HEAD PLATE (19) still does not sit on top of the first WEIGHT PLATE (22) or if there is excess slack in the cable system, adjust the threaded end of the LAT CABLE (20) and ADJUSTABLE GLIDE (53) accordingly and retighten the jam nuts. See figure 19
- For maximum performance, the HEAD PLATE (19) should just barely sit on the top WEIGHT PLATE (22)
- Attach the ERGO BAR (17) to the ball end of LAT CABLE (20) using one SNAP LINK (57) as shown in FIGURE 19.
- Attach the ANKLE STRAP (25) to the 12 LINK CHAIN (26) using one SNAP LINK (57) as shown in FIGURE 19

Thank you for purchasing the ParaBody 220 Gym System. If unsure of proper use of equipment, call your local ParaBody distributor or call the ParaBody customer service department at (800) 328-9714

MAINTENANCE

Please note:

- * We recommend cleaning your product (pads and frame) on a regular basis, using warm soapy water. Touch-up paint can be purchased from your ParaBody customer service representative at (800) 328-9714.

- * Inspect equipment daily. Tighten all loose connections and replace worn parts immediately. Failure to do so may result in serious injury

- * Lubricate guide rods with a teflon based (or equivalent) lubricant on a regular basis

*** PLEASE RECORD THE INFORMATION REQUESTED BELOW. IN THE EVENT YOU MAY NEED SERVICE YOU WILL BE ASKED FOR THIS INFORMATION. REMEMBER TO FILL OUT YOUR WARRANTY REGISTRATION CARD AND MAIL BACK.**

MODEL # _____

SERIAL # _____

DATE OF PURCHASE: _____

DEALERS NAME: _____

DEALERS PHONE # _____

Thank you for purchasing the ParaBody 220 Gym System.

LIMITED WARRANTY

ParaBody extends the following LIMITED WARRANTY to the original owner of the ParaBody products. The Warranty terms apply to IN HOME USE ONLY.

1. **LIMITED WARRANTY ON FRAME AND WELDS.** If the frame of the ParaBody product or a weld should crack or break, it will be repaired or replaced by ParaBody. Terms: Lifetime – for so long as the Customer owns the ParaBody product.
2. **LIMITED WARRANTY ON PARTS.** If the following parts are defective in material or workmanship, ParaBody will supply replacement parts: all bolts, nuts, washers, bearings, bushings, pulleys, thumbscrews, collars, cable retaining clips, adjustable pre-stretch slides, roller pad shafts, allen head bolts, weight selector pin, weight stack shaft, set screws, protector caps, adjustment chain, center pin, plunger, spring and knob. Terms: Lifetime – for so long as the Customer owns the ParaBody product.
3. **LIMITED WARRANTY ON CABLES AND UPHOLSTERY.** If the coated cables or upholstery are defective in material or workmanship, ParaBody will repair or replace them, at its option. Terms: Three (3) years.
4. **CONDITIONS AND EXCEPTIONS.** Any product misuse, abuse or alteration, any attempt to repair by a person other than an authorized ParaBody Service Center, any improper assembly, accident, or any other condition resulting from occurrences beyond the control of ParaBody will void this Limited Warranty.
5. **REPLACEMENT AND REPAIR EXPENSES.** ParaBody will provide only replacement parts or repair under this warranty. The Owner is responsible for all other costs. Such costs may include, but are not limited to: a. labor charges for service, removal, repair or reinstallation of the ParaBody product or any component part; b. shipping, delivery, handling and administrative charges for returning parts to ParaBody; and c. all necessary or incidental costs related to installation of the replacement parts.
6. **SHIPPING.** If shipping by the Owners is deemed necessary (in sole discretion of ParaBody), parts should be shipped in their original carton or equivalent packaging, fully insured with shipping charges prepaid. ParaBody will not assume any responsibility for any loss or damage incurred in shipping.
7. **CLAIM PROCEDURES.** If service on your ParaBody product is required during the warranty period, please contact our Customer Service Department at 1-800-328-9714 for instructions regarding returning or replacing parts. Please have available the following information: (i) the dealer's name; (ii) the date of purchase; (iii) the serial # (s) of your product (the serial number location is called out on the final assembly drawing included with your assembly instruction); (iv) a description of the nature of the problem.
8. **OWNER'S RIGHT.** This Limited Warranty gives you specific legal rights. You may also have other rights, which vary depending on local law.
9. **LIMITATION OF IMPLIED WARRANTIES.** All implied warranties, except to the extent prohibited by applicable law, shall have no greater duration than the warranty period set forth above. There are no warranties which extend beyond the description in this Limited Warranty. Because local laws do not allow limitations on how long an implied warranty lasts, the above limitations may not apply to you.
10. **DISCLAIMER.** No other express warranty has been made or will be made on behalf of ParaBody with respect to any ParaBody product or the operation, repair or replacement of any ParaBody product. ParaBody shall not be responsible for injury, loss of use of the ParaBody product, inconvenience, loss or damage to personal property, whether direct or indirect, and incidental or consequential damages, so the above limitation or exclusion may not apply to you.

NOTES:

LIFE FITNESS CONSUMER DIVISION

14150 Sunfish Lake Blvd. Ramsey Minnesota, 55303 U.S.A.

Tel: 763.323.4500 Fax: 763.323.4797

800.328.9714 (Toll-free within the U.S. and Canada)

www.parabody.com

INTERNATIONAL OFFICES

Life Fitness Atlantic BV
Atlantic Headquarters
Bijdorpplein 25-31
2992 LB Barendrecht
The Netherlands
Phone: (180) 646 666
Fax: (180) 646 703

Life Fitness EUROPE GmbH
Siemensstrasse 3
85716 Unterschleissheim
Germany
Phone: (089) 31 77 51-0
Fax: (089) 31 77 51 99

Life Fitness Italia S.R.L.
Via Elvas 92
39042 Bressanone
Italy
Phone: 39 (472) 835-470
Fax: 39 (472) 833-150

Life Fitness Asia Pacific Limited
Room 2610, Miramar Tower
132 Nathan Road, Tsimshatsui
Kowloon, Hong Kong
Phone: (852) 2891-6677
Fax: (852) 2575-6001

Life Fitness (UK) Ltd.
Queen Adelaide
Ely, Cambs CB7 4UB
United Kingdom
Phone CSS: (01353) 665507
Fax CSS: (01353) 666719

Life Fitness Benelux N.V.
Bijdorpplein 25-31
2992 LB Barendrecht
The Netherlands
Phone: 31 (180) 64 66 69
Fax: 31 (180) 64 66 99

Life Fitness Japan
8/F, Nippon Brunswick Building
5-27-7 Sendagaya
Shibuya-Ku, Tokyo 151-0051
Japan
Phone: 81 (3) 3359-4309
Fax: 81 (3) 3359-4307

Life Fitness Do Brazil
Al. Rio Negro, 433-Predio 2-Sala 2
3º andar (Confab)
Aplhavelle-Barueri-Sao Paulo
CEP: 06454-904
Brazil
Phone: 55 (11)7295-2217
Fax: 55 (11) 7295-2218