

Introduction

Welcome to the world of **STAR TRAC**. In your hands is the **STAR TRAC Elliptical Edge Service Manual**. This manual is designed to be easy to use, providing detailed instructions on how to service and maintain the Elliptical Edge.

We highly recommend that you read the entire manual prior to performing any maintenance or repair procedure. The information on the following pages will enable you to begin easily, quickly and safely.

Contents

How to Use the Manual	1.2
Precautions	1.3
Product Support Assistance	1.4
Tools and Materials	1.5
Elliptical Edge Overview	1.7

THIS IS NOT AN OWNER'S MANUAL. This Service Manual is intended for use by qualified repair technicians as a guide to diagnose and correct service problems.

The Service Manual is divided into six sections. Each section is provided with its own Table of Contents to assist in locating specific topics and procedures. Titles and major headings are located at the top of every page.

The Service Manual contains the following sections:

Section 1: Introduction - Provides a general overview of the Elliptical Edge, outlines safety precautions to be observed when performing maintenance or repair, and lists tools and materials required.

Section 2: Preventive Maintenance Schedules - Outlines periodic preventive maintenance checks and services; provides detailed procedures for specific maintenance tasks.

Section 3: Diagnostics - Describes how to access and use built-in diagnostic and customizing features and capabilities.

Section 4: Troubleshooting - Provides information designed to help diagnose and correct equipment problems. Troubleshooting information is arranged in a Symptom - Probable Cause - Suggested Remedy format.

Section 5: Parts Replacement - Provides step-by-step illustrated procedures to remove and install authorized in-field replacement parts.

Section 6: Parts Breakdown - Contains an illustrated listing of all parts and assemblies contained in the Elliptical Edge.

Precautions

The following general precautions apply whenever performing any maintenance or parts replacement procedure on the Elliptical Edge:

1. Read each procedure COMPLETELY before starting any work. Give particular attention to all NOTES, CAUTIONS and/or WARNINGS.
2. If the optional external wall powered power pack is used with the unit, MAKE SURE the power pack is unplugged from the wall before starting any work.
3. When disconnecting cable connectors, ALWAYS pull on the connector itself, NEVER the wires.



Product Support Assistance

PRODUCT SUPPORT DEPARTMENT

STAR TRAC Product Support Department sets the industry standard in Customer Service and Technical Assistance world wide. Providing superior product support and customer service is at the very heart of STAR TRAC's business philosophy. This commitment to service has been a major contributor to STAR TRAC's success and growth in the worldwide fitness equipment industry.

Technical Assistance

- When purchasing a part or requesting technical assistance, please contact our Product Support Department: CALL TOLL-FREE: 1-800-535-4634 or 800-503-1221 US and CANADA or 714-669-1660.
- When placing a call, please have the following information available:
 1. STAR TRAC model.
 2. STAR TRAC serial number.
 3. Problem statement/symptom.

After Hours Voicemail Direct

- CALL TOLL-FREE: 1-800-486-4736
- When placing a call, please have the following information available:
 1. STAR TRAC model.
 2. STAR TRAC serial number.
 3. Problem statement/symptom.
 4. Return phone number and contact name.

Fax Requests

- Domestic and international: FAX 714-669-0739
- When Placing the fax, please supply the following information:
 1. STAR TRAC model.
 2. STAR TRAC serial number.
 3. Problem statement/symptom.
 4. Return phone fax number and contact name.
 5. Purchase order or reference number.
 6. Part description and quantity.
 7. Ship to/bill to.

Product Support Documentation Access

Web page <http://www.startrac.com/support/>

Docufacts CALL TOLL FREE: 1-800-429-3228 ext. 640 US and Canada or 714-253-3878 for a list of Product Support Procedures and Bulletins.

Tools and Materials

The following tools and materials are required to perform adjustment and parts replacement procedures for the Elliptical Edge:

TOOUMATERIAL	USED FOR
Flat head screwdriver	Shuttle Adjustment
Phillips head screwdriver	Communication Cable Replacement Display Power Cable Replacement Cable Harness Replacement Local Control Board Replacement Battery Replacement Shuttle Replacement Skate Rail Replacement Stride Belt Replacement Transmission Bearings Replacement Crank Bearings replacement
5/64-in. Allen Wrench	Crank Bearings Replacement
3/32-in. Allen Wrench	Display Panel Replacement Communication Cable Replacement Display Power Cable Replacement Transmission Bearings Replacement
7/64-in. Allen Wrench	Crank Bearings Replacement
1/8-in. Allen Wrench	Skate Rail Replacement Stride Belt Replacement
5/32-in. Allen Wrench	Shuttle Replacement Skate Rail Replacement
3/16-in. Allen Wrench	Stride Belt Replacement Crank Bearings Replacement
1/2-in open-end wrench	Cable Harness Replacement
9/16-in. open-end wrench	Transmisstion Bearings Replacement Crank Bearings Replacement
3/16-in. socket wrench	Shuttle Replacement Skate Rail Replacement
7/16-in. socket wrench*	Skate Rail Replacement Stride Belt Replacement
1/2-in. socket wrench*	Skate Rail Replacement Stride Belt Replacement

Tools and Materials

TOOUMATERIAL	USED FOR
9/16-in. socket wrench	Transmission Bearings Replacement Crank Bearings Replacement
Needle-nose clippers	Cable Harness Replacement
Needle-nose pliers	Skate Rail Replacement
External Retainer Ring Pliers (13/32-1-in. with 0.051 tip diameter)	Crank Bearings Replacement
Rubber Mallet	Transmission Bearings Replacement Crank Bearings Replacement
Belt tensioner gauge	Transmission Bearings Replacement Crank Bearings Replacement
Tape	Communication Cable Replacement Display Power Cable Replacement
Tie Straps	Cable Harness Replacement

Elliptical Edge Overview

THIS INFORMATION TO BE PROVIDED UPON RECEIPT OF THEORY OF OPERATION SOURCE DATA AND BLOCK DIAGRAM.

Preventive Maintenance Schedules

Performing regular scheduled preventive maintenance is essential in keeping your Elliptical Edge in top operating condition. Without preventive maintenance, normal wear and tear may cause cumulative effects, such as misalignment and early replacement of parts.

This section provides a list of factory-recommended preventive maintenance requirements, along with detailed procedures for performing each task.

Contents

Preventive Maintenance Chart	2.2
Shuttle Alignment	2.3
Stride Belt Adjustment	2.4
Crank Belt Adjustment	2.5

Preventive Maintenance Chart

The Preventive Maintenance Chart lists the scheduled maintenance tasks for the Elliptical Edge. The chart lists the time interval when each procedure should be performed, and provides the general steps necessary to perform the task. In some cases, the chart references detailed maintenance procedures provided later in the section.

D = Daily; W = Weekly; Q = Quarterly (depending on the amount of use, Quarterly procedures may need to be performed more frequently).

INTERVAL			PROCEDURE
D	W	Q	
•			Clean dust and dirt from the unit using a soft, clean cloth dampened with a non-abrasive liquid cleaner. Give particular attention to the display panel, handrails and heart rate grips (if used).
•			Clean dust, dirt, oils or other contaminants from inside the skate rails (the shuttle tracks), and on the shuttle rollers, using a soft, clean cloth and a non-abrasive liquid cleaner. If needed, remove stubborn accumulations by scrubbing with a soft-bristle brush (such as a toothbrush). NEVER use a wire brush or any abrasive material to clean the skate rails or shuttle rollers. <i>IMPORTANT: Regular cleaning of the skate rails and shuttle rollers is CRITICAL to proper operation of the unit. Accumulations of dust and dirt on the skate rails or shuttle rollers can result in rough operation, misalignment of the shuttles and excessive wear on the skate rails and shuttle rollers.</i>
	•		Vacuum the floor under and around the unit. MAKE SURE that the unit is at its maximum elevation when vacuuming (or move the unit to another location).
	•		Check the display panel and handrails to ensure they are securely attached to the unit. Retighten the screws as needed.
	•		Inspect the Sport Utility Display panel for evidence of wear. Contact STAR TRAC Customer Support if replacement of the Sport Utility Display panel is necessary.
		•	Check each shuttle for misalignment or excessive sideplay. Realign the shuttles as needed (see Shuttle Alignment, page 2.3).
		•	Check each stride belt for proper tension. Adjust the stride belt tension as needed (see Adjusting Stride Belt Tension, page 2.4).
		•	Check the crank belt for proper tension. Adjust the crank belt tension as needed (see Adjusting Crank Belt Tension, page 2.5).

Shuttle Alignment

Misaligned shuttles can cause rough operation, excessive noise during use, and uneven or early wear of the skate rails and shuttle rollers.

The center rollers on each shuttle are equipped with eccentric cams which allow the shuttles to be adjusted to remove sideplay.

Tools Required:

Flat head screwdriver

Check the shuttle alignment:

1. Grasp the shuttle with one hand, and rock the shuttle from side to side on the skate rail.
2. There should be little or no evidence of movement (sideplay). The shuttle rollers should fit snugly inside the skate rails.
3. If excessive sideplay is noted, realignment of the shuttle(s) is necessary.

Realign the shuttle(s):

1. Grasp the shuttle with one hand, and rock the shuttle from side to side on the skate rail. Determine whether one or both sides of the shuttle show signs of excessive sideplay.
2. Using flat head screwdriver, rotate the shuttle center roller screw a quarter turn clockwise. Recheck the shuttle for sideplay.
3. If sideplay has increased, adjust the roller screw counterclockwise. If sideplay has decreased, continue to adjust the roller screw, a quarter turn at a time, until sideplay has been removed.

Check and adjust the tension of each stride belt separately.

Tools Required:

Phillips head screwdriver
1-in. open-end wrench

Check the stride belt tension:

1. Hold the skate rail with one hand so it does not move.
2. With your other hand, try to move the shuttle back and forth along the skate rail.
3. If the shuttle DOES NOT move, stride belt tension does not need to be adjusted. If the shuttle DOES move, stride belt tension must be adjusted.

Adjust stride belt tension:

1. Using Phillips head screwdriver, remove the four Phillips head screws from the rear shroud filler panel.
2. Remove the panel from the rear shroud.
3. Using 1-in. open-end wrench, adjust the stride belt pulley nut clockwise, as needed, to increase stride belt tension.

Recheck the shuttle for movement along the skate rail. Continue to adjust the stride belt pulley nut until proper stride belt tension is obtained.
5. Position the rear shroud filler panel on the rear shroud.
6. Using Phillips head screwdriver, secure the filler panel to the rear shroud with the four Phillips head screws.

Crank Belt Adjustment

Tools Required:

Phillips head screwdriver
9/16-in. open-end wrench
Belt tensioner gauge

Remove the front shroud:

1. Using Phillips head screwdriver, remove the eight Phillips head screws from the front shroud.
2. Lift the front shroud off the unit.

Check the crank belt tension:

1. Using belt tensioner gauge, check that crank belt tension is 80 pounds.
2. If a belt tensioner gauge is not available, check the crank belt tension by pressing down hard on top of the belt, midway between the transmission idler pulley and the crank pulley. The belt should deflect between 3/8-in.-1/2-in. (9.5-12.5 mm).
3. If crank belt tension is less than 80 pounds, the crank belt must be adjusted.

Re-tension the crank belt:

1. Using 9/16-in. open-end wrench, loosen the transmission idler tension nut to allow adjustment of the transmission idler tension bolt.
1. Using 9/16-in. open-end wrench, tighten the transmission idler tension bolt to increase crank belt tension.
2. Using belt tensioner gauge to check crank belt tension, continue to tighten the transmission idler tension bolt to achieve 80 pounds tension.
 - If a belt tensioner gauge is not available, check the crank belt tension by pressing down hard on top of the belt, midway between the transmission idler pulley and the crank pulley. The belt should deflect between 3/8-in.-1/2-in. (9.5-12.5 mm).
3. Once the correct crank belt tension is obtained, tighten the transmission idler tension nut **SECURELY** using 9/16-in. open-end wrench.

Install the front shroud:

1. Install the front shroud in position on the unit.
2. Using Phillips head screwdriver, secure the front shroud to the unit with the eight Phillips head screws.

Diagnosics

The Elliptical Edge contains several customizing and diagnostics features. The customizing feature allows you to tailor unit operation to suit your particular needs. Diagnostics features let you view accumulated data related to machine usage, and check critical operating parameters as an aid in maintenance and troubleshooting.

These features include:

- Diagnostic LEOs - Provide an indication of the operating status of the Load Control Board (LCB) and the alternator.
- Display Maintenance Mode - Displays start-up and shut-down service messages as a result of self-test or when scheduled periodic maintenance is required.
- Display Settings Mode - Lets you modify certain operating and display settings for the unit.
- Service Settings Mode - Displays accumulated statistical data related to machine usage.
- Service Messages - Display during machine use if certain electrical failures or out-of-tolerance conditions are detected.
- System Measurements Mode - Lets you monitor critical electrical parameters under both idle and in-use conditions.

Contents

Diagnostic LEDs	:.....	3.2
Display Maintenance Mode		3.3
Display Settings Mode		3.4
Service Settings Mode		3.6
Service Messages	:.....	3.7
System Measurements Mode	~.....	3.8

The Load Control Board (LCB) is equipped with three diagnostic LEOs. These LEOs provide indications of the operating status of the LCB and the alternator.

The LCB diagnostic LEOs function as follows:

LED	FUNCTION
D2	This Led provides a steady series of flashes, at 20-per-second, indicating communication between the LCB and the display panel is functional. If this LED is off or flashes erratically, replacement of the LCB, the display panel or the communication cable may be required.
D3	This LED provides a steady series of flashes, at one-per-second, indicating the LCB microprocessor is functional and the loop circuit is operating. If this LED is off or flashes erratically, replacement of the LCB may be required.
D13	This LED is normally off. If alternator output voltage exceeds 19 volts, the LED lights steady on. This condition will also cause the "Needs Service" message to display (see Display Maintenance Mode for details).

NOTE: The diagnostic LEOs provide a general indication of certain equipment malfunctions. Refer to Section 4, Troubleshooting to aid in locating the most likely cause of the problem.

Display Maintenance Mode

The Elliptical Edge displays start-up or shutdown service messages if a display code is detected during use, or when periodic maintenance is due.

Service Messages at Start-up

The unit performs a self-test at the beginning of every workout. The self-test is initiated as soon as operation of the unit begins, and continues throughout the duration of the workout. **If** a failure in an electronic circuit or component is detected, one of the following messages will display:

Key Down	One or more keys on the keypad(s) are stuck in the depressed (on) position; maintenance service is required. Call Star Trac Customer Support for assistance.
Needs Service	Self-test has detected an electronic component failure; maintenance service is required. Call Star Trac Customer Support for assistance. Specific service messages describing the equipment malfunction or failure can be accessed and viewed using the Service Settings feature. Additional troubleshooting information is provided in Section 4.

Service Message at Shutdown

The Elliptical Edge displays a "Time for Service" message when a periodic (preventive) maintenance procedure is due. This message displays for 2-3 seconds at the end of a workout session. Call Star Trac Customer Support for assistance. Preventive maintenance procedures are outlined in Section 2.

The Display Settings Mode lets you view and modify several unit settings, which affect the way the machine operates during a workout. Use the keypad to enter the Display Settings Mode, view the current settings and make any desired changes.

To enter the Display Settings Mode:

1. Press and hold the "Enter", "0" and "1" keys at the same time.
2. While continuing to hold the "Enter" and "0" keys; release the "1" key. The unit will beep once, and the message "Display Settings" will show in the upper information display.
3. Release the "Enter" and "0" keys.

Once the unit is in the Display Settings Mode, use the keypad to select and enter changes to unit settings:

KEY	FUNCTION
"Scroll" Key	Press the "Scroll" key to scroll through the display settings and select the setting you wish to view or change (for each setting, the current value is displayed in the upper information window). Pressing and holding the "Scroll" key will scroll continuously through the available settings.
"Up-Down Arrow" Keys	Use the "Up-Down Arrow" keys to scroll through the available values for the setting and to select a new value. When a new value for the setting has been selected, press the "Scroll" key to save the new value and advance to the next setting.
	<i>NOTE: To return display settings to their original values after changes have been made and saved, you must MANUALLY re-enter the factory-default settings.</i>
"Enter" Key	Press the "Enter" key to exit the Display Settings Mode and return to the standard operating mode.

Display Settings Mode

The following display settings may be changed using the keypad as previously described:

SETTING	DESCRIPTION	DEFAULT VALUE
Maximum Work Time	Sets the maximum workout time, in minutes.	60 minutes
Heart Rate	Enables/disables the Polar heart rate pickup	Polar
Units	Sets the units display to English or Metric: <ul style="list-style-type: none"> • English - distance is displayed in tenths of a mile; speed is displayed in miles-per-hour; weight is displayed in pounds • Metric - distance is displayed in tenths of a kilometer; speed is displayed in kilometers-per-hour; weight is displayed in kilograms. 	English
Weight	Sets the weight displayed as default when a preset program is selected. This value is a default only; users are prompted to enter their actual weight (used for calculating total calories burned).	155

NOTE: When setting metric units, weight must be set at 70 kg.

The Elliptical Edge records and stores usage data which may be used as an aid in maintaining the unit and diagnosing malfunctions. The Service Settings Mode lets you view this usage data, as well as software version numbers and the serial number and date of manufacture for the unit.

To enter the Service Settings Mode:

1. Press and hold the "Enter", "0" and "2" keys at the same time.
2. While continuing to hold the "Enter" and "0" keys, release the "2" key. The unit will beep once, and the message "Service Settings" will show in the upper information display.
3. Release the "Enter" and "0" keys.

Once the unit is in the Service Settings Mode, use the keypad to view service settings, service messages, or system measurements:.

The following stored data may be viewed while in the Service Settings Mode:

ITEM	DESCRIPTION
Display Version	Version of software currently installed in the display.
LCB Version	Version of software currently installed in the Load Control Board.
Serial#	Serial number of the unit.
Manufacture Date	Unit manufacture date (displayed as DDMMYY).
Workout Hours	Total number of operating hours accumulated on the unit to date.
Workout Distance	Total number of distance units accumulated on the machine to date. Distance units are displayed in either miles or kilometers (depending on the "Units" selection (English or Metric) chosen in "Display Settings").
Battery Hours	Total number of hours the battery has been used under power (displayed in thousands of hours). Need to reset to zero when battery replaced.
Last Keystrokes	Displays the last five keys pressed prior to a software or system failure.

Service Messages

The Elliptical Edge self-test function monitors the electronics while a workout is in progress. If a malfunction or failure in a monitored circuit occurs during a workout, the "Needs Service" message displays (as described in Display Maintenance Mode), and a specific service message is set. Service message can be accessed and viewed from the Service Settings Mode.

To view Service Messages:

- On entering the Service Settings Mode, press the "S" key while in "service settings". "Service message" will display in the upper information display.
- Press the "Scroll" key to view service messages (if any have been set). Pressing and holding the "Scroll" key will advance through all service messages.
- Press the "Enter" key to exit Service Messages and return to the Service Settings Mode.

The following service messages may be set by the self-test function:

MESSAGE	DEFINITION
No Communication	A communication failure has occurred between the upper display and the Load Control Board (LCB). Communications cable or LCB replacement may be required.
No Alternator Output	The alternator is not producing an output voltage (the unit will not provide a load/workout to the user). Alternator, load resistor or alternator cable harness replacement may be required.
Alternator Field Open	The alternator field has an open circuit. Alternator, alternator cable harness or LCB replacement may be required.
No Load	The alternator is working, but the unit is not providing a load (workout) to the user. Alternator cable harness or LCB replacement may be required.
Low Battery	The battery charge voltage is low. This may be a result of low usage. The battery can be recharged either by operating the machine by connecting the external wall-powered power pack and the machine is in use for several hours. With the machine not in use the recharging of the battery will take 24 hours to reach full charge. NOTE: <i>If the "Low Battery" message is set frequently, battery replacement or charging system service may be required.</i>

The System Measurements Mode lets you measure critical voltages in the battery/alternator circuits, under both idle and operating conditions.

To enter the System Measurements Mode:

- On entering the Service Settings Mode, press the "8" key while in "service settings". "Measurements" will display in the upper information display.
- Press the "Scroll" key to view the system measurements available.
- Press the "Enter" key to exit the System Measurements Mode and return to the Service Settings Mode.

Once the unit is in the System Measurements Mode, use the [Arrow Keys] to select the desired system measurement.

The following voltage measurements may be taken while in the System Measurements Mode:

MEASUREMENT	DESCRIPTION
Battery Voltage	<p>Measures and displays battery output voltage while the unit is idle. Output voltage for a normal battery should range between 6.2-7.7 volts.</p> <ul style="list-style-type: none"> • Output voltage below 6.2 volts indicates a low battery charge or a damaged battery. • Output voltage above 7.7 volts indicates a fault in the Load Control Board.
Alternator Voltage	<p>Measures and displays alternator output voltage while the unit is in use. To check the alternator output voltage:</p> <ul style="list-style-type: none"> • Pedal the unit at a speed above 1.5 miles-per-hour. • Alternator output voltage should range between 11.5-13.5 volts. Voltages outside this range indicate a fault in the Load Control Board.
Wall Power	<p>Measures and displays the voltage delivered to the unit from an optional external wall-powered power pack while the unit is idle. An acceptable power pack voltage will range between 11.0-18.0 voltage. The power pack should be replaced if the voltage is outside this range.</p>
Load Voltage	<p>Measures and displays the voltage generated across the workout loading resistor while the unit is in use. To measure the load voltage:</p> <ul style="list-style-type: none"> • Pedal the unit at a speed above 1.5 miles-per-hour. • Load voltage should range between 1.0-10.0 volts. Voltages outside this range indicate a fault in the Load Control Board. A lower voltage indicates a high resistance which is normal.

Troubleshooting

The Elliptical Edge incorporates built-in self-test and diagnostic features which assist in diagnosing electrical system problems. **Section 3: Diagnostics** contains the procedures for using these self-test and diagnostic features.

This section contains troubleshooting information for mechanical problems which may occur as a result of normal usage of the Elliptical Edge. Troubleshooting information is presented in chart form. The Troubleshooting Chart identifies symptoms of problems which may occur, lists the most probable cause(s) for the problem, and provides suggested remedies to return the unit to operating condition.

Contents

Troubleshooting Chart

4.2

Troubleshooting Chart

SYMPTOM	PROBABLE CAUSE	SUGGESTED REMEDY
Shuttle is loose (forward and backward movement on skate rail)	1. The stride belt is worn or has stretched.	1. Adjust the stride belt tension (see Stride Belt Adjustment, page 2.4)
		2. Replace the stride belt (see Stride Belt Replacement, page 5.18)
	2. The clutch bearing is slipping.	1. Replace the transmission assembly (see Transmission Bearings Replacement, page 5.20)
		2. Replace the transmission shaft (see Transmission Bearings Replacement, page 5.20)
Shuttle is loose (up and down movement or sideplay on skate rail)	1. The shuttle out of adjustment	1. Adjust the shuttle's eccentric rollers (see Shuttle Adjustment, page 2.3)
	2. The shuttle rollers are worn	1. Adjust the shuttle's eccentric rollers (see Shuttle Adjustment, page 2.3)
		2. Replace the shuttle (see Shuttle Replacement, page 5.13)
Front of skate rail falls rapidly with little or no resistance	1. The crank belt is loose or worn.	1. Re-tension the crank belt as needed (see Crank Belt Adjustment, page 2.5)
		2. Replace the crank belt (NO PROCEDURE RECEIVED FOR CRANK BELT REPLACEMENT)
	2. The alternator belt is loose or worn.	1. Retension the alternator belt as needed (NO PROCEDURE RECEIVED FOR ALTERNATOR BELT RETENSIONING)
		2. Replace the alternator belt (NO PROCEDURE RECEIVED FOR ALTERNATOR BELT REPLACEMENT)

Crank Belt Adjustment

SYMPTOM	PROBABLE CAUSE	SUGGESTED REMEDY
Crank pulley makes excessive noise during use	1. The crank pulley is loose on the crank shaft.	1. Tighten the crank pulley Allen screws (see Crank Bearings Replacement, page 5.22)
Shuttle makes noise as it move along skate rail	1. There is dirt or debris build-up on the shuttle rollers.	1. Clean the shuttle rollers (see Preventive Maintenance Chart, page 2.2)
	2. There is dirt or debris build-up in the skate rail tracks.	1. Clean the skate rails (see Preventive Maintenance Chart, page 2.2)

Parts Replacement

This section contains parts replacement procedures for assemblies and components of the Elliptical Edge which are authorized for in-field replacement. Parts should be replaced **ONLY** when indicated by diagnosis and troubleshooting. There are no parts which are to be replaced as a part of scheduled preventive maintenance.

Contents

Display Panel Replacement..	5.2
Communication Cable Replacement	5.3
Display Power Cable Replacement	5.5
Cable Harness Replacement	5.7
LCB Replacement	5.9
Battery Replacement	5.11
Shuttle Replacement	5.12
Skate Rail Replacement	5.15
Stride Belt Replacement	5.2
Transmission Bearings Replacement	5.24
Crank Bearings Replacement	5.27

Tools Required:

3/32-in. Allen Wrench

Remove the display panel:

NOTE: Use one hand to support the display panel during removal.

NOTE: DO NOT pull on the wires when disconnecting the cable from the display panel.

1. Using 3/32-in. Allen wrench, remove the seven Allen screws from the back of the display panel. BE SURE to support the display panel after the Allen screws have been removed.
2. CAREFULLY disconnect the communication cable from display panel connector J4 and the display power cable from display panel connector J7, by grasping and pulling the cable connectors.
3. Remove the display panel.

Install the display panel:

NOTE: Use one hand to support the display panel during installation.

NOTE: The cable connectors are keyed to prevent improper connection.

1. Place the display panel in position on the unit. BE SURE to support the display panel until the Allen screws have been installed.
2. CAREFULLY connect the communication cable and power cable to the display panel. MAKE SURE the connectors are properly aligned when reconnecting. DO NOT force the connectors.
 - Connect the communication cable to display panel connector J4.
 - Connect the display power cable to display panel connector J7.
3. Using 3/32-in. Allen wrench, secure the display panel to the frame with the seven Allen screws. Tighten the Allen screws firmly. DO NOT OVERTIGHTEN.

Communication Cable Replacement

Tools and Materials Required:

Phillips head screwdriver
3/32-in. Allen wrench
Tape

Remove the front shroud:

1. Using Phillips head screwdriver, remove the eight Phillips head screws from the front shroud.
2. Lift the front shroud off the unit.

Disconnect the communication cable from the LeB:

1. CAREFULLY disconnect the communication cable from LCB connector J1 by grasping and pulling the cable connector. See Diagram 8

NOTE: DO NOT pull on the wires when disconnecting the communication cable from the LeB.

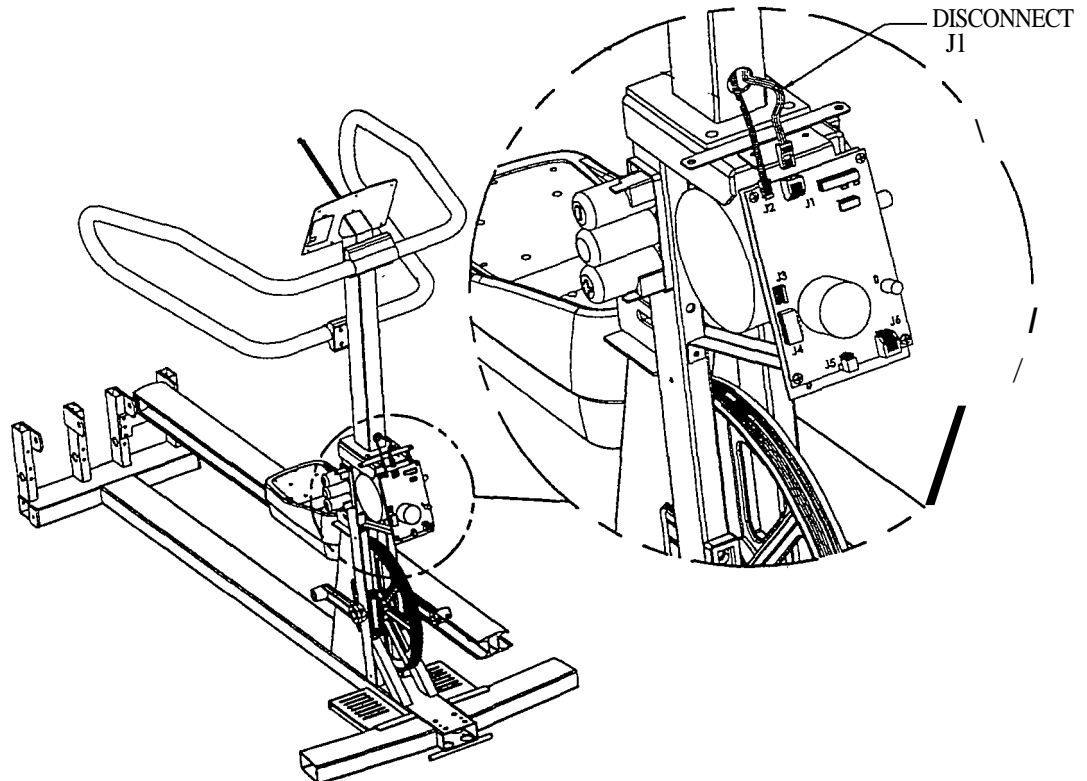

Diag.B

Remove the display panel:

1. Using 3/32-in. Allen wrench, remove the seven Allen screws from the back of the display panel. BE SURE to support the display panel after the Allen screws have been removed.

NOTE: Use one hand to support the display panel during removal.

NOTE: DO NOT pull on the wires when disconnecting the cables from the display panel.

NOTE: To prevent the display power cable from falling through the display neck opening, tape the display power cable to the top of the display neck.

NOTE: Use one hand to support the display panel during installation.

NOTE: The cable connectors are keyed to prevent improper connection.

NOTE: The cable connector is keyed to prevent improper connection.

2. CAREFULLY disconnect the communication cable from display panel connector J4 and the display power cable from display panel connector J7, by grasping and pulling the cable connectors.
3. Remove the display panel.

Install the communication cable:

1. Tape one end of the new communication cable to the bottom (LCB end) of the old communication cable.
2. Using the old communication cable as a routing guide, GENTLY pull the new communication cable up through the display neck. The communication cable should route smoothly and easily through the display neck. DO NOT force the cable through the neck.
3. Remove the tape and separate the new communication cable from the old communication cable.

Install the display panel:

1. Place the display panel in position on the unit. BE SURE to support the display panel until the Allen screws have been installed.
2. CAREFULLY connect the communication cable and power cable to the display panel. MAKE SURE the connectors are properly aligned when reconnecting. DO NOT force the connectors.
 - Connect the communication cable to display panel connector J4.
 - Connect the display power cable to display panel connector J7.
3. Using 3/32-in. Allen wrench, secure the display panel to the frame with the seven Allen screws. Tighten the Allen screws firmly. DO NOT OVERTIGHTEN.

Connect the communication cable to the LCB:

1. CAREFULLY connect the communication cable to LCB connector J1. MAKE SURE the connector is properly aligned when reconnecting. DO NOT force the connector.

Install the front shroud:

1. Install the front shroud in position on the unit.
2. Using Phillips head screwdriver, secure the front shroud to the unit with the eight Phillips head screws.

Display Power Cable Replacement

Tools and Materials Required:

Phillips head screwdriver
3/32-in. Allen wrench
Tape

Remove the front shroud:

1. Using Phillips head screwdriver, remove the eight Phillips head screws from the front shroud.
2. Lift the front shroud off the unit.

Disconnect the display power cable from the LeB:

1. CAREFULLY disconnect the display power cable from LCB connector J2 by grasping and pulling the cable connector. **See Diagram C.**

NOTE: DO NOT pull on the wires when disconnecting the communication cable from the LeB.

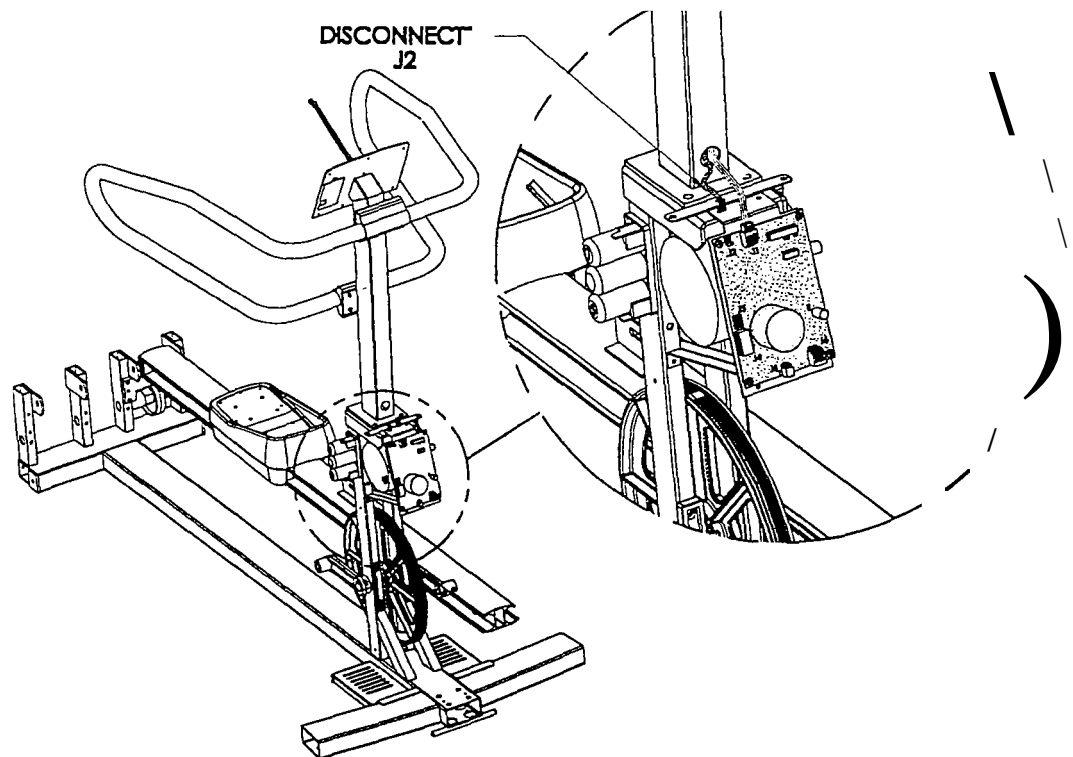

Diag. C

Remove the display panel:

1. Using 3/32-in. Allen wrench, remove the seven Allen screws from the back of the display panel. BE SURE to support the display panel after the Allen screws have been removed.

NOTE: Use one hand to support the display panel during removal.

NOTE: DO NOT pull on the wires when disconnecting the cables from the display panel.

NOTE: To prevent the communication cable from falling through the display neck opening, tape the communication cable to the top of the display neck.

E: Use one hand support the display panel during installation.

NOTE: The cable connectors are keyed to prevent improper connection.

NOTE: The cable connector is keyed to prevent improper connection.

2. CAREFULLY disconnect the communication cable from display panel connector J4 and the display power cable from display panel connector J7, by grasping and pulling the cable connectors.
3. Remove the display panel.

Install the display power cable:

1. Tape one end of the new display power cable to the bottom (LCB end) of the old display power cable.
2. Using the old display power cable as a routing guide, GENTLY pull the new display power cable up through the display neck. The display power cable should route smoothly and easily through the display neck. DO NOT force the cable through the neck.
3. Remove the tape and separate the new display power cable from the old display power cable.

Install the display panel:

1. Place the display panel in position on the unit. BE SURE to support the display panel until the Allen screws have been installed.
2. CAREFULLY connect the communication cable and power cable to the display panel. MAKE SURE the connectors are properly aligned when reconnecting. DO NOT force the connectors.
 - Connect the communication cable to display panel connector J4.
 - Connect the display power cable to display panel connector J7.
3. Using 3/32-in. Allen wrench, secure the display panel to the frame with the seven Allen screws. Tighten the Allen screws firmly. DO NOT OVERTIGHTEN.

Connect the display power cable to the LCB:

1. CAREFULLY connect the display power cable to LCB connector J2. MAKE SURE the connector is properly aligned when reconnecting. DO NOT force the connector.

Install the front shroud:

1. Install the front shroud in position on the unit.
2. Using Phillips head screwdriver, secure the front shroud to the unit with the eight Phillips head screws.

Cable Harness Replacement

Tools Required:

Phillips head screwdriver
1/2-in. open-end wrench
Needle-nose clippers
Tie straps (20 req'd)

Remove the front shroud:

1. Using Phillips head screwdriver, remove the eight Phillips head screws from the front shroud.
2. Lift the front shroud off the unit.

Disconnect the cable harness from the LeB:

1. CAREFULLY disconnect the following cables from the LCB by grasping and pulling the cable connectors: **See Diagram D.**
 - Disconnect the battery cable from LCB connector J3.
 - Disconnect the alternator/load resistor cable LCB connector J4.
 - Disconnect the external power cable LCB connector J5.

NOTE: DO NOT pull on the wires when disconnecting the cables from the LeB.

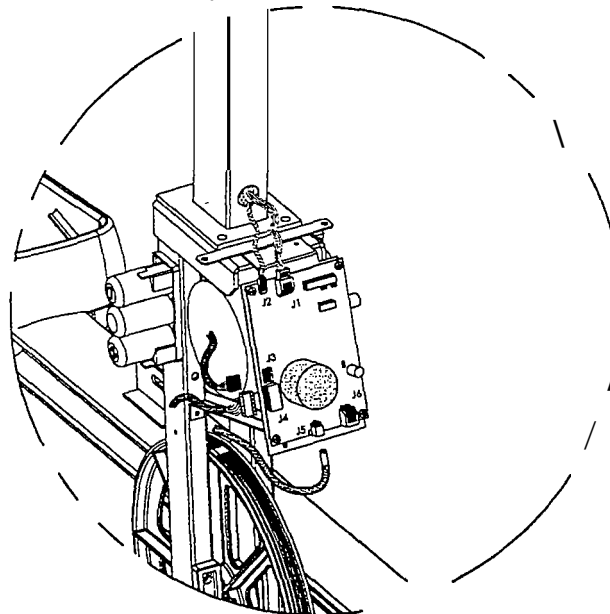

Diag. D

Disconnect the cable harness from the alternator:

1. Using 1/2-in. open-end wrench, disconnect the following wires from the alternator terminals:
 - Disconnect the two red wires from the alternator B terminal.
 - Disconnect the black wire from the alternator E terminal.

NOTE: Note the location of the 20 tie straps to aid in reinstallation

- Disconnect the yellow wire from the alternator EXC terminal.
 - Disconnect the white wire from the alternator P terminal.
 - Disconnect the green wire from the alternator S terminal.
2. Using needle-nose clippers, cut and remove the 20 tie straps securing the cable harness to the frame; remove the cable harness.
 3. Separate the red (+) and black (-) battery cables from the cable harness.

Remove the load resistor:

1. Using Phillips head screwdriver, remove the two Phillips head screws securing the load resistor to the frame; remove the load resistor.

Install the load resistor:

1. Using Phillips head screwdriver, secure the new load resistor to the frame with two Phillips head screws. **TIGHTEN THE SCREWS SECURELY.**

Connect the cable harness to the alternator:

1. Reroute the new cable harness and the red (+) and black (-) battery cables along the frame. Use the 20 tie straps to secure the cable harness and battery cables to the frame at the locations noted during removal.
2. Using 1/2-in. open end wrench, connect the following wires to the alternator terminals: **TIGHTEN THE WIRE CONNECTION SECURELY.**
 - Connect the two red wires to the alternator B terminal.
 - Connect the black wire to the alternator E terminal.
 - Connect the yellow wire to the alternator EXC terminal.
 - Connect the white wire to the alternator P terminal.
 - Connect the green wire to the alternator S terminal.

Connect the cable harness to the LCB:

1. **CAREFULLY** connect the following cables to the LCB. **MAKE SURE** the connectors are properly aligned when reconnecting. **DO NOT** force the connectors.
 - Connect the battery cable to LCB connector J3.
 - Connect the alternator/load resistor cable to LCB connector J4.
 - Connect the external power cable to LCB connector J5.

Install the front shroud:

1. Install the front shroud in position on the unit.
2. Using Phillips head screwdriver, secure the front shroud to the unit with the eight Phillips head screws.

NOTE: The cable connectors are keyed to prevent improper connection.

Load Control Board Replacement

Tools Required:

Phillips head screwdriver

Remove the front shroud panel:

1. Using Phillips head screwdriver, remove one Phillips head screw from the front shroud panel. Remove the front shroud panel to gain access to the LCB.

Remove the LeB:

1. CAREFULLY disconnect the following cables from the LCB by grasping and pulling the cable connectors: **See Diagram E.**
 - Disconnect the communication cable from LCB connector J1.
 - Disconnect the display power cable from LCB connector J2.
 - Disconnect the battery cable from LCB connector J3.
 - Disconnect the alternator/load resistor cable from LCB connector J4.
 - Disconnect the external power cable from the connector J5.
 - Disconnect the Fitlinxx cable from LCB connector J6.

NOTE: DO NOT pull on the wires when disconnecting the cables from the LeB.

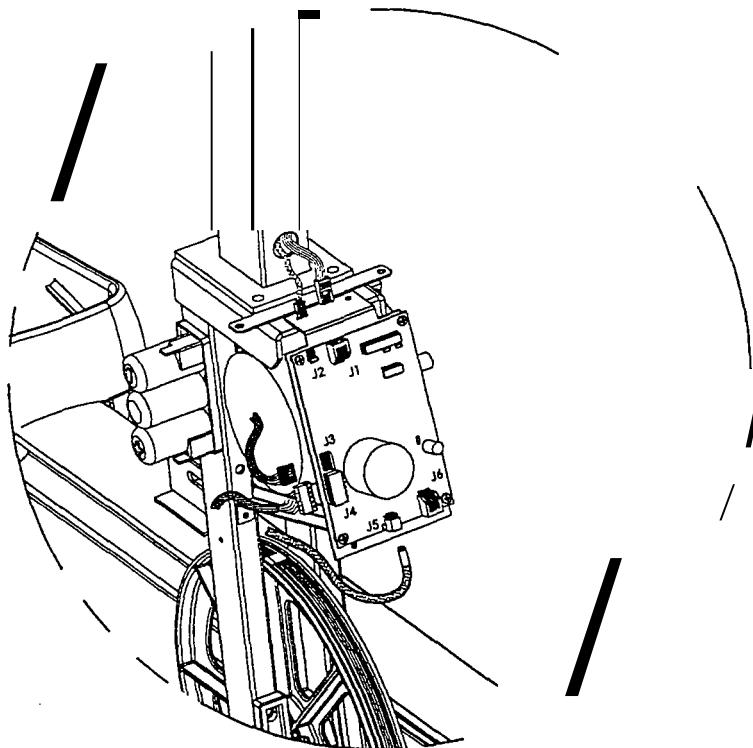

Diag. E

NOTE: Use one hand to support the LCa when removing the bottom Phillips head screw from the LCa.

2. Using Phillips head screwdriver, remove the two top Phillips head screws securing the LCB to the frame.
3. Using Phillips head screwdriver, remove the bottom Phillips head screw securing the LCB to the frame. Remove the LCB.

Install the LeB:

NOTE: Use one hand to support the LCa while installing the three Phillips head screws.

1. Support the new LCB in position on the frame. Using Phillips head screwdriver, install the top two Phillips head screws securing the LCB upper bracket to the frame. Install the bottom Phillips head screw securing the LCB lower bracket to the frame. Tighten the three screws firmly. **DO NOT OVERTIGHTEN.**
2. **CAREFULLY** connect the following cables to the LCB. **MAKE SURE** the connectors are properly aligned when reconnecting,. **DO NOT** force the connectors.
 - Connect the communication cable to LCB connector J1.
 - Connect the display power cable to LCB connector J2.
 - Connect the battery cable to LCB connector J3.
 - Connect the alternator/load resistor cable to LCB connector J4.
 - Connect the external power cable to LCB connector J5.
 - Connect the Fitlinxx cable to LCB connector J6.

NOTE: The cable connectors are keyed to prevent improper connection.

Install the front shroud panel:

1. Position the front shroud panel on the front shroud.
2. Using Phillips head screwdriver, secure the front shroud panel to the front shroud with one Phillips head screw.

Battery Replacement

Tools Required:

Phillips head screwdriver

Remove the front shroud:

1. Using Phillips head screwdriver, remove the eight Phillips head screws from the front shroud.
2. Lift the front shroud off the unit.

Remove the battery:

1. CAREFULLY disconnect the black (-) and red (+) lead wires from the battery terminals by grasping and pulling the wire connectors.
2. Using Phillips head screwdriver, remove the two screws securing the battery to the frame; remove the battery. **See Diagram F.**

NOTE: DO NOT pull on the wires when disconnecting from the battery.

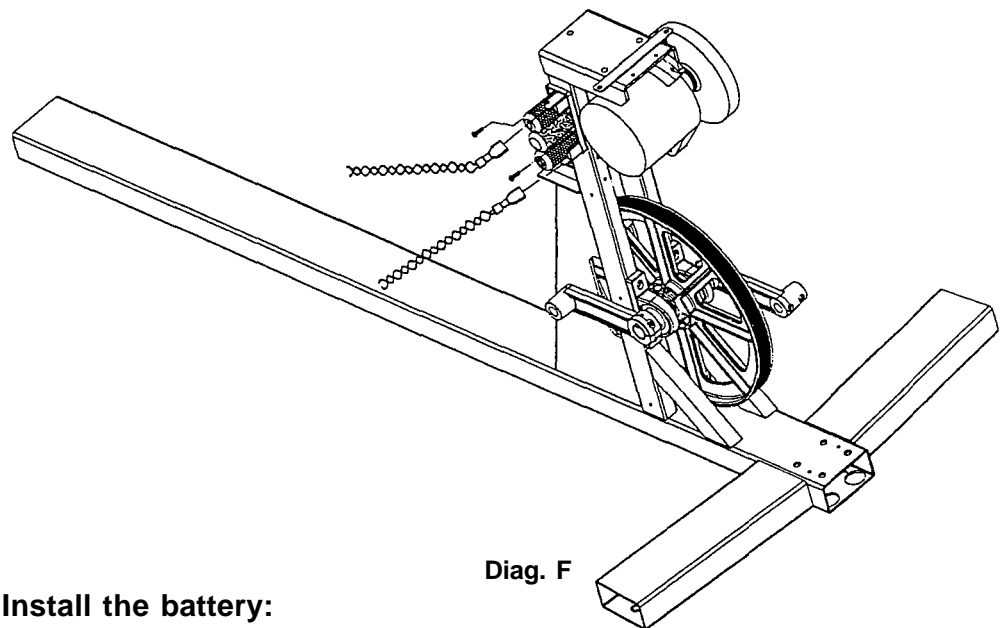

Diag. F

Install the battery:

1. Position the new battery on the frame. Using Phillips head screwdriver, install the two Phillips head screws through the battery to secure the battery to the frame. **TIGHTEN THE SCREWS FIRMLY.**
2. Connect the lead wires to the battery:
 - Connect the black (-) lead wire to the top battery terminal marked (-)
 - Connect the red (+) lead wire to the bottom battery terminal marked (+).

NOTE: When installing the battery, make sure the negative (-) terminal is positioned at the top.

Install the front shroud:

1. Install the front shroud in position on the unit.
2. Using Phillips head screwdriver, secure the front shroud to the unit with the eight Phillips head screws.

Shuttle Replacement

NOTE: Remove and install ONLY ONE shuttle at a time.

Tools Required:

Phillips head screwdriver
Needle nose plier
Flat head screwdriver
½-in Hex head socket
3/16-in. socket wrench
5/32-in. Allen wrench

Remove the front shroud:

1. Using Phillips head screwdriver, remove the eight Phillips head screws from the front shroud.
2. Lift the front shroud off the unit.

Remove the shuttle:

1. Slide the shuttle completely forward on the skate rail.
2. Using 3/16-in. hex head socket wrench, remove the four screws (from underneath the shuttle) securing the footpad to the shuttle. Remove the footpad.
3. Using 3/16-in. hex head socket wrench, remove the four screws (at the rear of the shuttle) securing the shuttle to the capture plates.
4. Using needle nose pliers, CAREFULLY pull the two cotter pins out from the belt tension pulley (at the rear of the unit). See Diagram G.
5. Using needle nose pliers, CAREFULLY pull the belt tension anchor pin out from the belt tension pulley. See Diagram H.

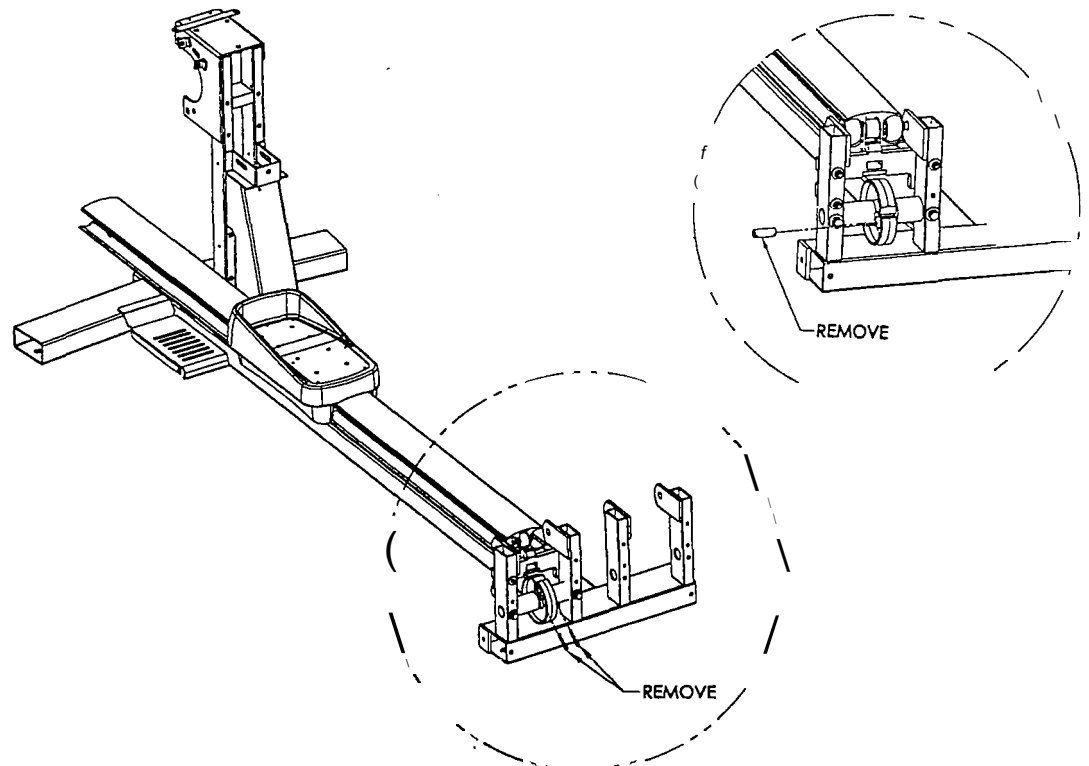

NOTE: Adjust the position of the skate rail as needed to allow removal of the crank arm shaft.

NOTE: MAKE SURE the two Allen screws engage the flats on the crank arm shaft.

NOTE: You may need to adjust the shuttle to remove excess side-play (see Section 2 for details).

6. Using 1/2-in. hex head socket wrench and 1/2-in. open-end wrench, remove the front stride belt pulley (and bolt) from inside the skate rail. **See Diagram I.**

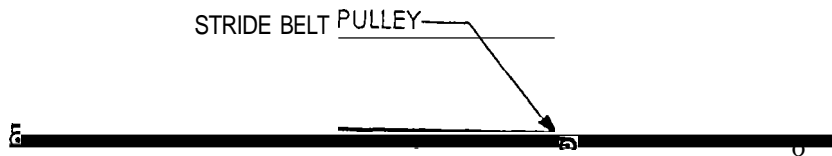

7. Using 5/32-in. Allen wrench, remove the two Allen screws from the crank arm. **See Diagram J.**

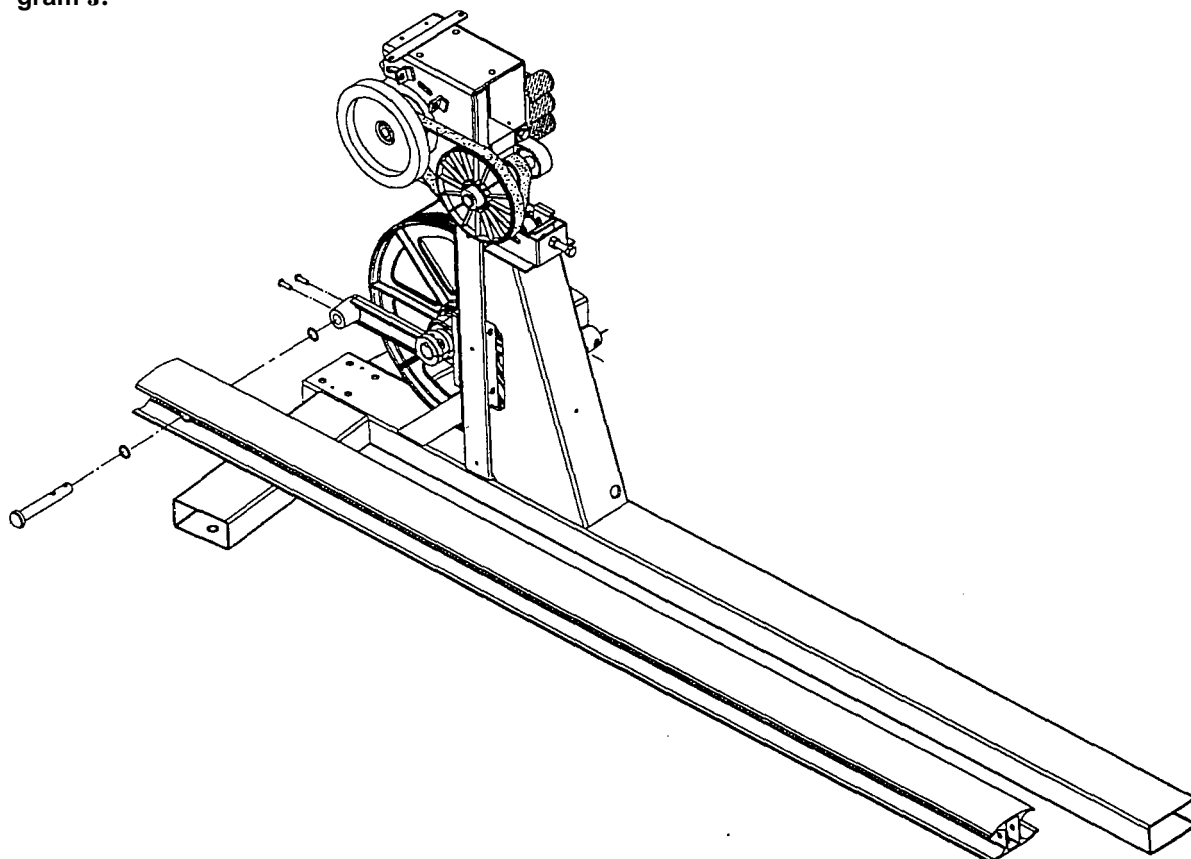

5. CAREFULLY slide the crank arm shaft and two nylon washers out of the skate rail. BE CAREFUL notto lose the two nylon washers.
6. Slide the shuttle forward and off of the skate rail.

Shuttle Replacement

Install the shuttle:

1. Slide the new shuttle on from the front of the skate rail.
2. Slide the shuttle along the skate rail and align the holes in the back of the shuttle with the holes in the captive plates.
3. Using 3/16-in. hex head socket wrench, secure the shuttle to the capture plates with the four screws. **TIGHTEN THE SCREWS SECURELY.**
4. Install one nylon washer on the crank arm shaft. **CAREFULLY** insert the crank arm shaft through the skate rail, then install the remaining nylon washer on the crank arm shaft.
5. Insert the crank arm shaft through the crank arm.
6. Rotate the crank arm shaft, as needed, until the flats on the shaft are aligned with the holes in the crank arm.
7. Using 5/32-in. Allen wrench, install the two Allen screws in the crank arm. **TIGHTEN THE SCREWS SECURELY.**
8. Install the front stride belt pulley through the stride belt and rail. Using 1/2-in socket head and a 1/2-in open end wrench, secure the front stride belt pulley to the skate rail with the bolt. **TIGHTEN THE SOLT SECURELY.**
9. Insert the belt tension anchor pin in the belt tension pulley through the loop in the stride belt. Install the two cotter pins in the belt tension anchor pin.
10. Place the footpad in position on the shuttle. Using 3/16-in. hex head socket wrench, install the four Allen screws (from underneath the shuttle) to secure the footpad to the shuttle. **TIGHTEN THE SCREWS SECURELY.**

NOTE: MAKE SURE the two Allen screws engage the flats on the crank arm shaft.

NOTE: You may need to adjust the shuttle to remove excess side-play (see Section 2 for details).

Install the front shroud:

1. Install the front shroud in position on the unit.
2. Using Phillips head screwdriver, secure the front shroud to the unit with the eight Phillips head screws.

Skate Rail Replacement

NOTE: Remove and install ONLY ONE skate rail at a time.

Tools Required:

Phillips head screwdriver
7/16-in. socket wrench
1/2-in. socket wrench
1/2-in. open-end wrench
3/16-in. Allen wrench
5/32-in. Allen wrench
1/8-in. Allen wrench
Needle nose pliers

Remove the front shroud:

1. Using Phillips head screwdriver, remove the eight Phillips head screws from the front shroud.
2. Lift the front shroud off the unit.

Remove the rear shroud:

1. Using Phillips head screwdriver, remove the eight Phillips head screws from the rear shroud.
2. Lift the rear shroud off the unit.

Remove the skate rail:

1. Slide the shuttle completely forward on the skate rail.
2. Using 3/16-in. hex head socket wrench, remove the four screws (from underneath the shuttle) securing the footpad to the shuttle. Remove the footpad.
3. Using 3/16-in. hex head socket wrench, remove the four screws (at the rear of the shuttle) securing the shuttle to the capture plates.
4. Using needle nose pliers, CAREFULLY pull the section of the stride belt containing the capture plates out through the access hole in the side of the skate rail.
5. Using 1/8-in. Allen wrench, remove the three Allen screws from the top capture plate, and separate the capture plates from the stride belt. **See Diagram K.**

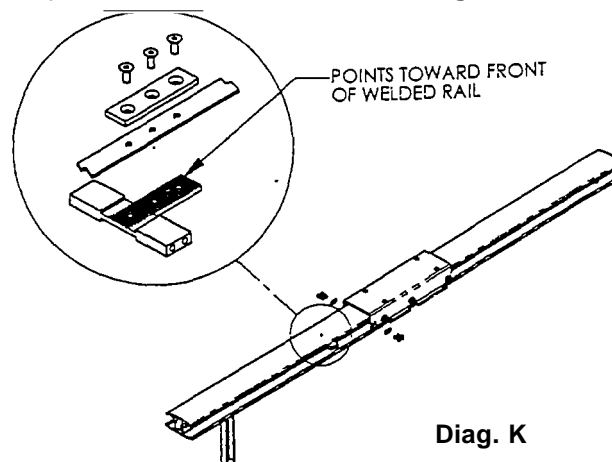

- Using needle nose pliers, CAREFULLY pull the two cotter pins out from the belt tension pulley (at the rear of the unit). See Diagram L.
- Using needle nose pliers, CAREFULLY pull the belt tension anchor pin out from the belt tension pulley. See Diagram M.

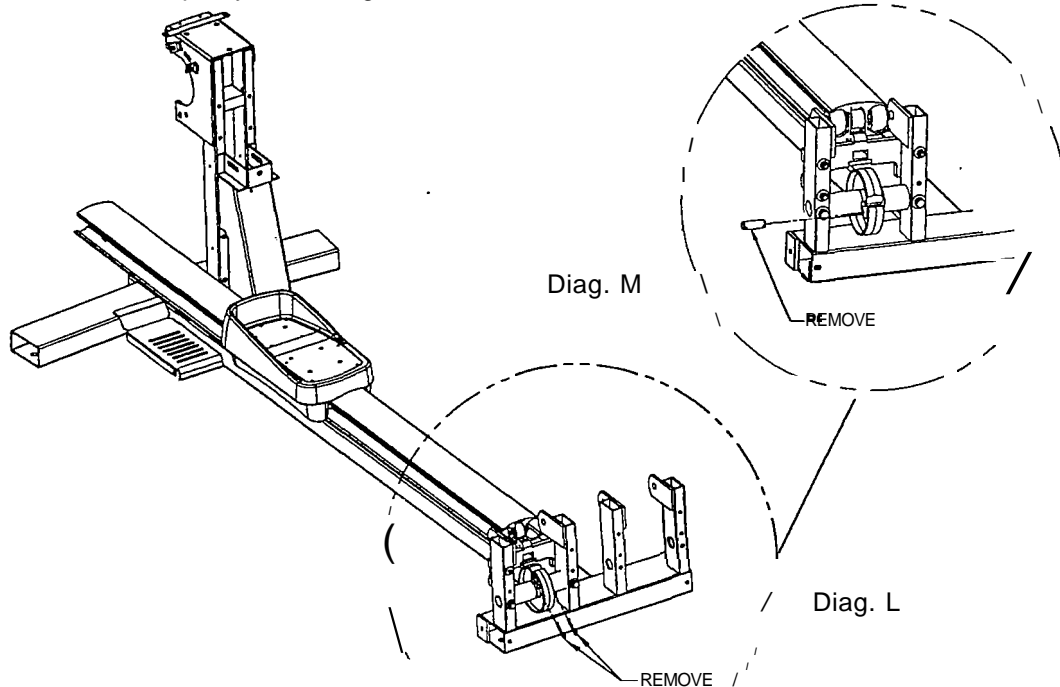

- Using 7/16-in. hex head socket wrench and 3/16-in. Allen wrench, remove the top two bolts from the belt guide bracket. Once the bolts are removed, CAREFULLY dislodge the stride belt from the groove in the guide bracket. See Diagram N.

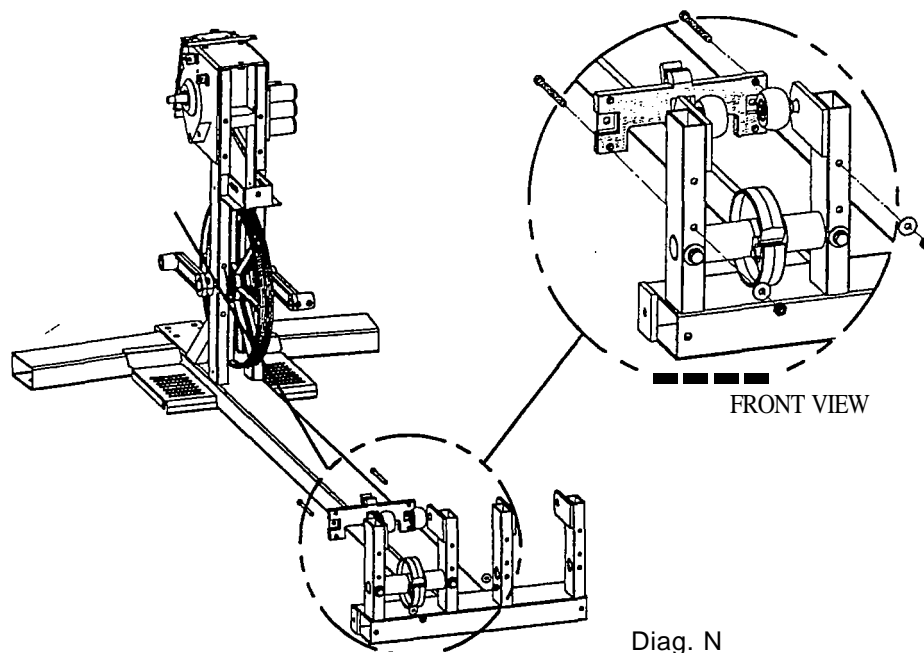

Skate Rail Replacement

9. Using 1/2-in. hex head socket wrench and 1/2-in. open-end wrench, remove the rear stride belt pulley (and bolt) from the skate rail. **See Diagram O.**

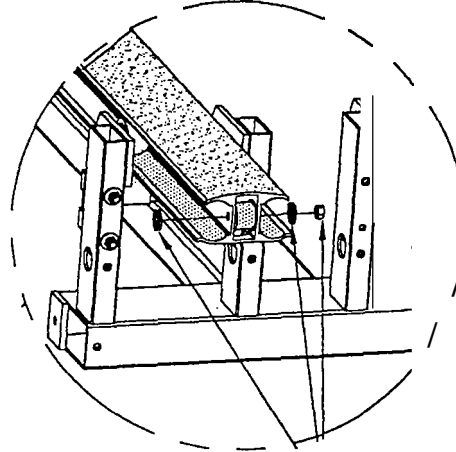

Diag.O

10. Using 1/2-in. hex head socket wrench and 1/2-in. open-end wrench, remove the front stride belt pulley (and bolt) from inside the skate rail. **See Diagram P.**

STRIDE BELT PULLEY



Diag. P

NOTE: Adjust the position of the skate rail as needed to allow removal of the crank arm shaft.

11. Pull the stride belt out through the back of the skate rail.
12. Using 5/32-in. Allen wrench, remove the two Allen screws from the crank arm.
13. **CAREFULLY** slide the crank arm shaft and two nylon washers out of the skate rail. **BE CAREFUL** not to lose the two nylon washers. **See Diagram Q.**

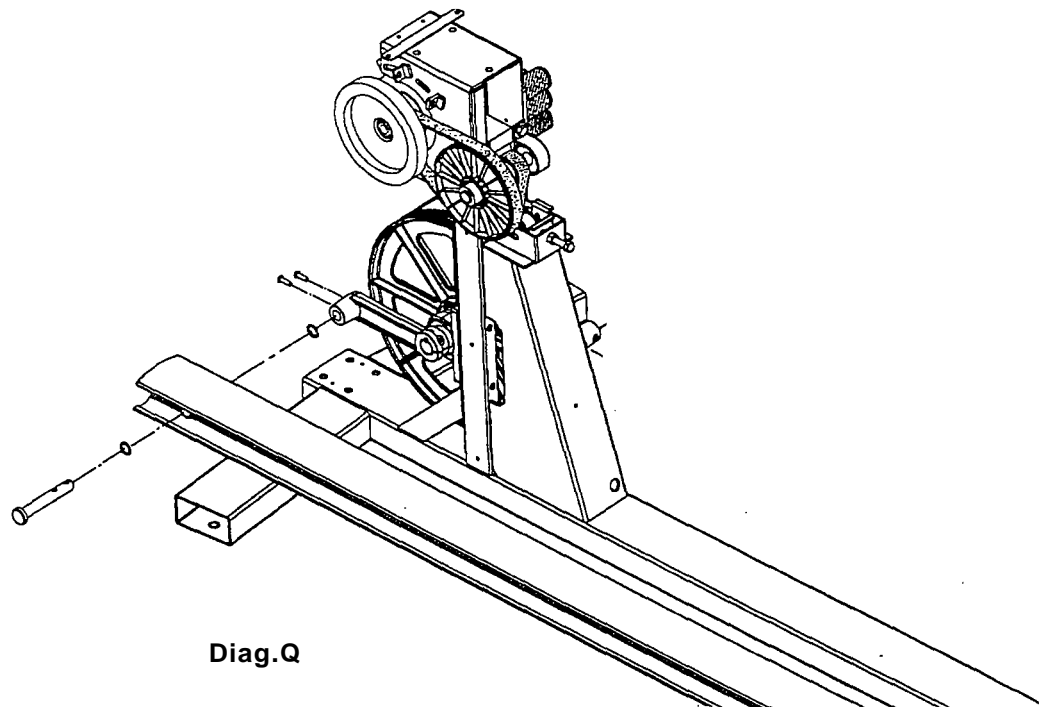

Diag.Q

14. CAREFULLY slide the skate rail off the frame by pushing the skate rail forward and off the front end.
15. Slide the shuttle off of the skate rail.

Reinstall the skate rail:

1. Slide the shuttle onto the skate rail.
2. Slide the skate rail on from the front of the frame, engaging the skate rail with the rollers attached to the rear of the frame.
3. Install one nylon washer on the crank arm shaft. CAREFULLY insert the crank arm shaft through the skate rail, then install the remaining nylon washer on the crank arm shaft.
4. Insert the crank arm shaft through the crank arm.
5. Rotate the crank arm shaft, as needed, until the flats on the shaft are aligned with the holes in the crank arm.
6. Using 5/32-in. Allen wrench, install the two Allen screws in the crank arm. **TIGHTEN THE SCREWS SECURELY.**
7. Using 1/2-in. hex head socket wrench, secure the skate rail to the rear frame with two bolts. **TIGHTEN THE BOLTS SECURELY.**
8. Insert the stride belt into the skate rail (from the rear end) and route the stride belt through the skate rail. **MAKE SURE** the belt is straight when installed in the skate rail.
9. Install the front stride belt pulley in the stride belt. Using 1/2-in. hex head socket wrench and 1/2-in. open end wrench, secure the front stride belt pulley to the skate rail with the bolt. **TIGHTEN THE BOLT SECURELY.**
10. Install the rear stride belt pulley in the stride belt. Using 1/2-in. hex head socket wrench and 1/2-in. open end wrench, secure the rear stride belt pulley to the skate rail with the bolt. **TIGHTEN THE BOLT SECURELY:**
11. Slide the shuttle forward on the skate rail until the shuttle rests against the front stride belt pulley.
12. Using needle nose pliers, CAREFULLY pull the section of the stride belt with the three holes out through the access hole in the side of the skate rail.
13. Assemble the capture plates on the stride belt, aligning the holes in the capture plates with the holes in the stride belt.
14. Using 1/8-in. Allen wrench, secure the capture plates to the stride belt with the three Allen screws. Insert the stride belt and capture plate back inside the skate rail.
15. Remove any extra slack from the stride belt by GENTLY pulling the stride belt out the rear of the skate rail. **MAKE SURE** the stride belt is tight around both the front and rear stride belt pulleys.
16. Insert the exposed end of the stride belt through the groove in the belt guide bracket.
17. Using 7/16-in. hex head socket wrench and 3/16-in. Allen wrench, secure the belt guide bracket to the frame with the two bolts. **TIGHTEN THE BOLTS SECURELY.**
18. Slide the shuttle back along the skate rail and align the four holes in the rear of the shuttle with the four holes in the capture plate.

NOTE: MAKE SURE the two Allen screws engage the flats on the crank arm shaft.

NOTE: When installing the stride belt in the skate rail, the punched holes in the belt face up, the arrows point to the rear of the skate rail.

Skate Rail Replacement>

NOTE: It may be necessary to adjust stride belt tension following skate rail replacement (see Section 2 for details).

NOTE: You may need to adjust the shuttle to remove excess side-play (see Section 2 for details).

19. Using 3/16-in. hex head socket wrench, secure the shuttle to the capture plate with the four screws. **TIGHTEN THE SCREWS SECURELY.**
20. Route the free end of the stride belt around the belt tension pulley, and insert through the pulley opening.
21. Insert the belt tension anchor pin in the belt tension pulley through the loop in the stride belt. Install the two cotter pins in the belt tension anchor pin
22. Place the footpad in position on the shuttle. Using 3/16-in. hex head socket wrench, install the four Allen screws (from underneath the shuttle) to secure the footpad to the shuttle. **TIGHTEN THE SCREWS SECURELY.**

Install the rear shroud:

1. Install the rear shroud in position on the unit.
2. Using Phillips head screwdriver, secure the rear shroud to the unit with the eight Phillips head screws.

Install the front shroud:

1. Install the front shroud in position on the unit.
2. Using Phillips head screwdriver, secure the front shroud to the unit with the eight Phillips head screws.

Tools Required:

Phillips head screwdriver
7/16-in. socket or open-end wrench
1/2-in. socket wrench
1/2-in. open-end wrench
3/16-in. Allen wrench
1/8-in. Allen wrench
Needle nose pliers

NOTE: Remove and install ONLY ONE stride belt at a time.

Remove the rear shroud:

1. Using Phillips head screwdriver, remove the eight Phillips head screws from the rear shroud.
2. Lift the rear shroud off the unit.

Remove the stride belt:

1. Using needle nose pliers, CAREFULLY pull the two cotter pins out from the belt tension pulley (at the rear of the unit).
2. Using needle nose pliers, CAREFULLY pull the belt tension anchor pin out from the belt tension pulley. See Diagram R.

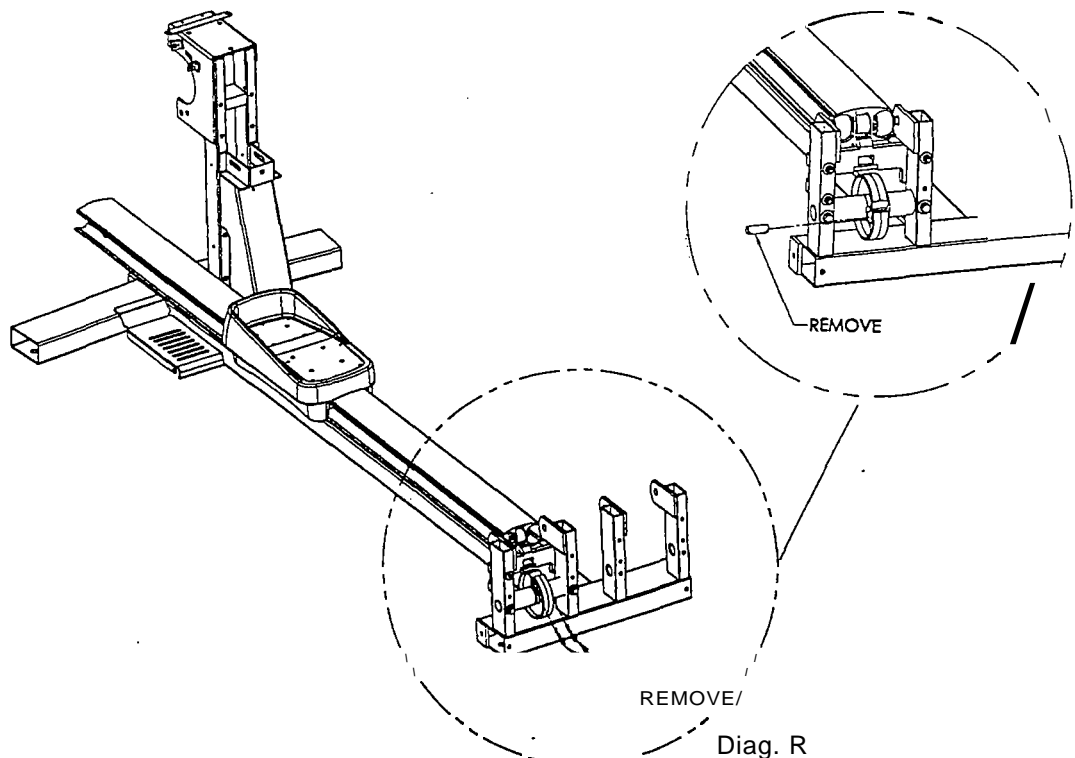

Stride Belt Replacement,

- Using 7/16-in. hex head socket wrench and 3/16-in. Allen wrench, remove the top two bolts from the belt guide bracket. Once the bolts are removed, CAREFULLY dislodge the stride belt from the groove in the guide bracket. See **Diagram S**.

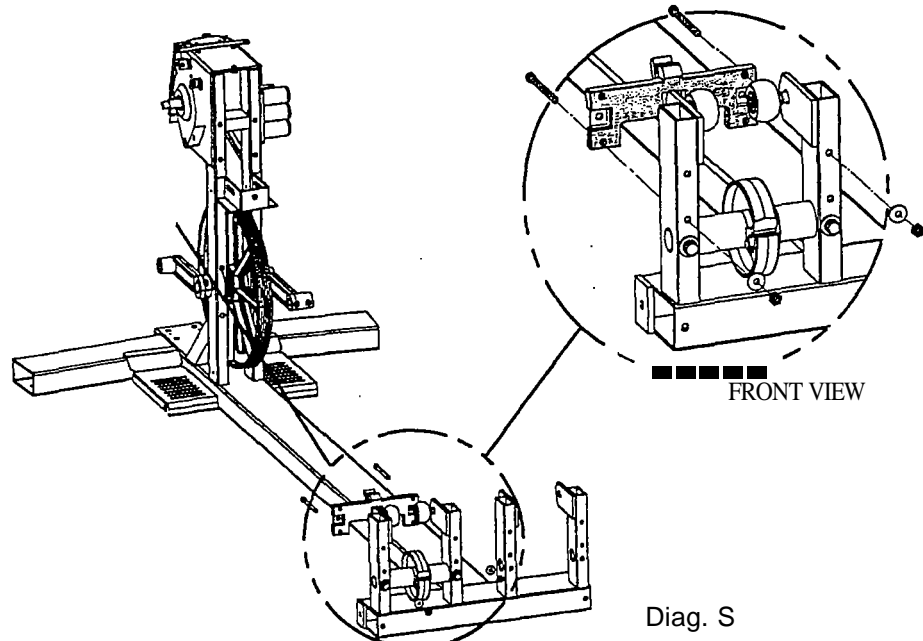

- Using 1/2-in. hex head socket wrench and 1/2-in. open-end wrench, remove the rear stride belt pulley (and bolt) from inside the skate rail. See **Diagram T**.

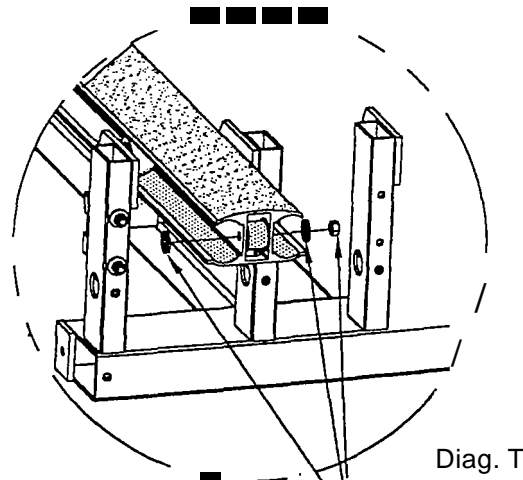

- Using 3/16-in. hex head socket wrench, remove the four screws (from underneath the shuttle) securing the footpad to the shuttle. Remove the footpad.
- Using 3/16-in. hex head socket wrench, remove the four screws (at the rear of the shuttle) securing the shuttle to the capture plates.
- Using needle nose pliers, CAREFULLY pull the section of the stride belt containing the capture plates out through the access hole in the side of the skate rail.

- Using 1/8-in. Allen wrench, remove the three Allen screws from the top capture plate, and separate the capture plates from the stride belt. See Diagram U.

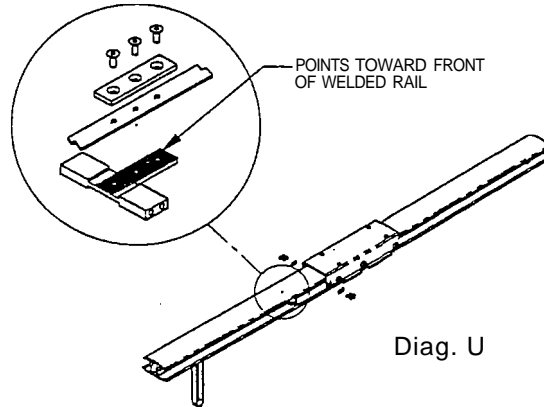

Diag. U

- Using 1/2-in. hex head socket wrench and 1/2-in. open-end wrench, remove the front stride belt pulley (and bolt) from inside the skate rail. See Diagram V.

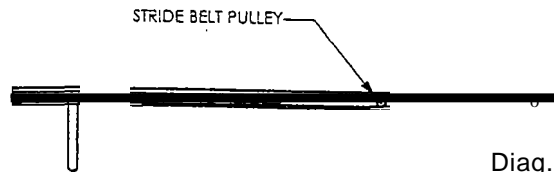

Diag. V

- Pull the stride belt out through the back of the skate rail.

Install the stride belt:

- Insert the stride belt into the skate rail (from the rear end) and route the stride belt through the skate rail. **MAKE SURE** the belt is straight when installed in the skate rail. See Diagram W.



Diag. W

- Install the front stride belt pulley in the stride belt. Using 1/2-in. hex head socket wrench and 1/2-in. open end wrench, secure the front stride belt pulley to the skate rail with the bolt. **TIGHTEN THE BOLT SECURELY.**
- Install the rear stride belt pulley in the stride belt. Using 1/2-in. hex head socket wrench and 1/2-in. open end wrench, secure the rear stride belt pulley to the skate rail with the bolt. **TIGHTEN THE BOLT SECURELY.**
- Slide the shuttle forward on the skate rail until the shuttle rests against the front stride belt pulley.
- Using needle nose pliers, **CAREFULLY** pull the section of the stride belt with the three

NOTE: When installing the stride belt in the skate rail, the punched holes in the belt face up, the arrows point to the rear of the skate rail.

Stride Belt Replacement

holes out through the access hole in the side of the skate rail.

6. Assemble the capture plates on the stride belt, aligning the holes in the capture plates with the holes in the stride belt.
7. Using 1/8-in. Allen wrench, secure the capture plates to the stride belt with the three Allen screws. Insert the stride belt and capture plate back inside the skate rail.
8. Remove any extra slack from the stride belt by GENTLY pulling the stride belt out the rear of the skate rail. MAKE SURE the stride belt is tight around both the front and rear stride belt pulleys.
9. Insert the exposed end of the stride belt through the groove in the belt guide bracket.
10. Using 7/16-in. hex head socket wrench and 3/16-in. Allen wrench, secure the belt guide bracket to the frame with the two bolts. TIGHTEN THE BOLTS SECURELY.
11. Slide the shuttle back along the skate rail and align the four holes in the rear of the shuttle with the four holes in the capture plate.
12. Using 3/16-in. hex head socket wrench, secure the shuttle to the capture plate with the four screws. TIGHTEN THE SCREWS SECURELY.
13. Route the free end of the stride belt around the belt tension pulley, and insert through the pulley opening.
14. Insert the belt tension anchor pin in the belt tension pulley through the loop in the stride belt. Install the two cotter pins in the belt tension anchor pin
15. Place the footpad in position on the shuttle. Using 3/16-in. hex head socket wrench, install the four Allen screws (from underneath the shuttle) to secure the footpad to the shuttle. TIGHTEN THE SCREWS SECURELY.

NOTE: It may be necessary to adjust stride belt tension following belt replacement (see Section 2 for details).

NOTE: You may need to adjust the shuttle to remove excess side-play (see Section 2 for details).

Install the rear shroud

1. Install the rear shroud in position on the unit.
2. Using Phillips head screwdriver, secure the rear shroud to the unit with the eight Phillips head screws.

Tools Required:

Phillips head screwdriver
9/16-in. socket wrench
9/16-in. open-end wrench
3/32-in. Allen wrench
Rubber mallet
Belt tensioner gauge

Remove the front shroud:

1. Using Phillips head screwdriver, remove the eight Phillips head screws from the rear shroud.
2. Lift the rear shroud off the unit.

Remove the transmission assembly:

1. Using 9/16-in. open-end wrench, loosen the transmission idler tension nut and bolt so the crank belt is completely loose. See Diagram X.

NOTE: If needed, GENTLY tap the transmission pulley with a rubber mallet to remove from the transmission shaft.

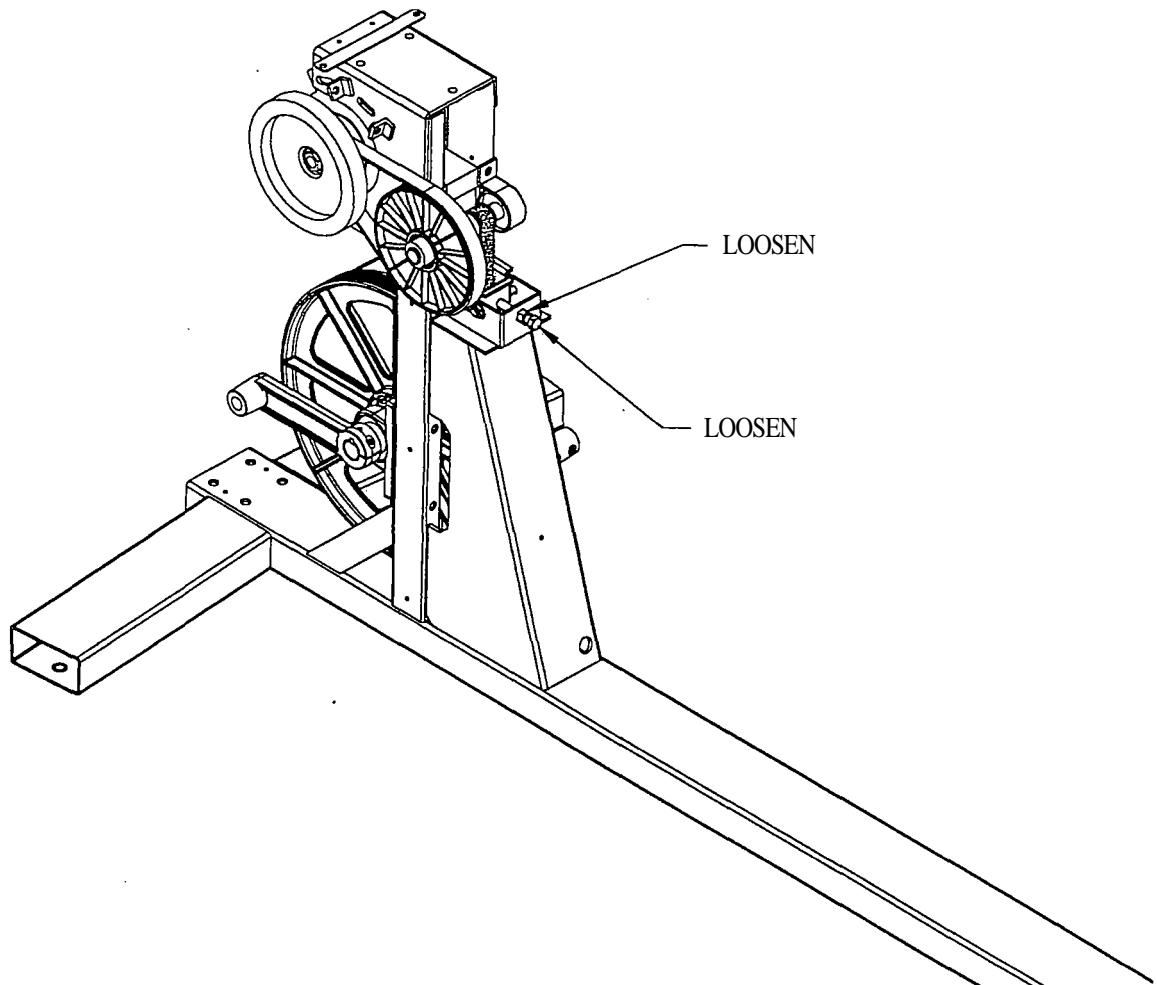

Transmission Bearings Replacement

2. Loosen the alternator belt from the transmission pulley. Using 3/32-in. Allen wrench, loosen the two Allen screws on the alternator pulley, and GENTLY slide the alternator pulley and key off the transmission shaft. BE CAREFUL not to lose the alternator pulley key, See Diagram Y.

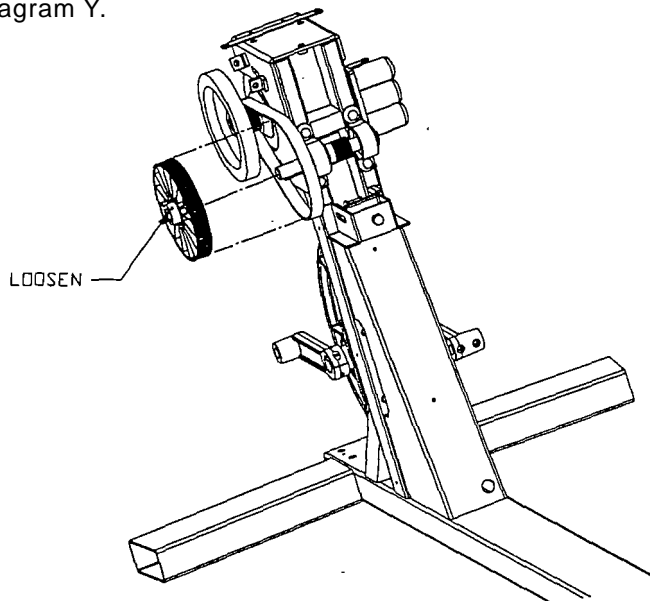

3. Using 9/16-in. hex head socket wrench and 9/16-in. open-end wrench, remove the four bolts and nuts securing the transmission shaft pillow blocks to the frame. CAREFULLY remove the transmission assembly from the frame. See Diagram Z.

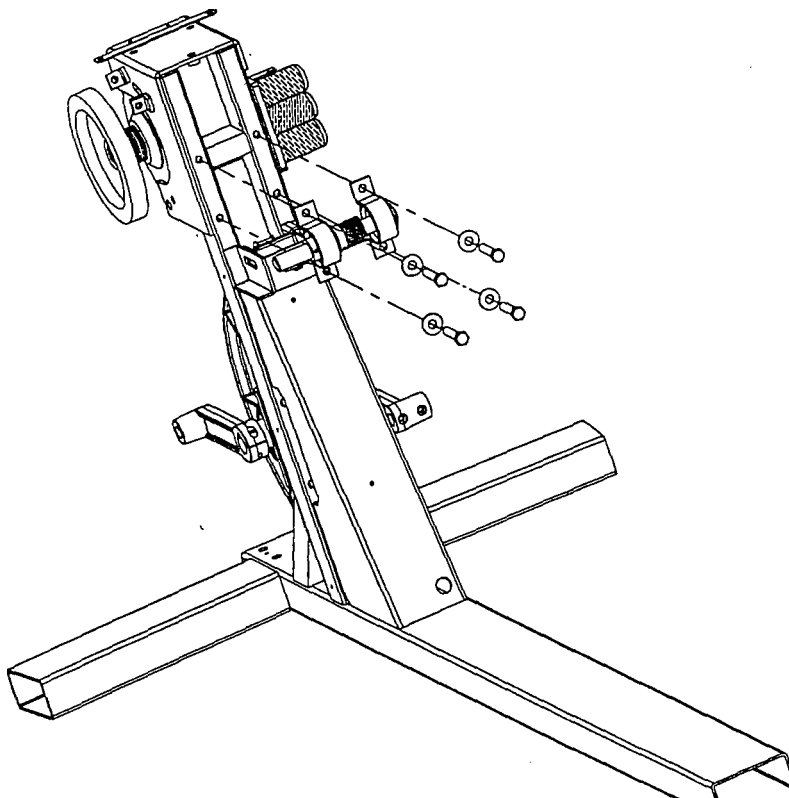

NOTE: Support the free end of the crank belt to keep it from falling inside the frame.

4. Using 3/32-in. Allen wrench, loosen the Allen screws in the transmission shaft pillow blocks and gently slide the pillow blocks of the transmission shaft.
5. Using 3/32-in. Allen wrench, loosen the Allen screw or the transmission idler pulley and gently slide the transmission idler pulley of the transmission shaft. **BE CAREFUL** not to lose the transmission idler pulley key.

Install the transmission assembly:

1. Install the transmission idler pulley key on the transmission shaft, then **GENTLY** slide the transmission idler pulley onto the transmission shaft.
2. Using 3/32-in. Allen wrench, tighten the Allen screw on the transmission idler pulley firmly. **DO NOT OVERTIGHTEN THE ALLEN SCREW.**
3. Install the two pillow blocks on the transmission shaft with the Allen screws facing outward (toward the ends of the transmission shaft). **MAKE SURE** the Allen screws in the pillow blocks align with the flats on the transmission shaft.
4. Using 3/32-in. Allen wrench, tighten the pillow block Allen screws firmly. **DO NOT OVERTIGHTEN THE ALLEN SCREWS.**
5. Insert the transmission assembly through the crank belt and position the transmission assembly in place on the frame. **MAKE SURE** the crank belt is properly positioned on the transmission idler pulley.
6. Using 9/16-in. hex head socket wrench and 9/16-in. open-end wrench, secure the transmission assembly to the frame with the four bolts and nuts. **TIGHTEN THE NUTS SECURELY.**
7. **GENTLY** slide the alternator pulley and key onto the transmission shaft.
8. Using 3/32-in. Allen wrench, tighten the two Allen screws on the alternator pulley. Pull the alternator belt into place on the alternator pulley.

Re-tension the transmission pulley:

1. Using 9/16-in. open-end wrench, tighten the transmission idler tension bolt to increase crank belt tension.
2. Using belt tensioner gauge to check crank belt tension, continue to tighten the transmission idler tension bolt to achieve 80 pounds tension.
 - If a belt tensioner gauge is not available, check the crank belt tension by pressing down hard on top of the belt, midway between the transmission idler pulley and the crank pulley. The belt should deflect between 3/8-in.-1/2-in. (9.5-12.5 mm).
3. Once the correct crank belt tension is obtained, tighten the transmission idler tension nut **SECURELY** using 1/2-in. open-end wrench.

Install the front shroud:

1. Install the front shroud in position on the unit.
2. Using Phillips head screwdriver, secure the front shroud to the unit with the eight Phillips head screws.

NOTE: If needed, back off the transmission idler tension nut to allow proper adjustment of the transmission idler pulley.

Tools Required:

Phillips head screwdriver
9/16-in. socket wrench
9/16-in. open-end wrench
7/64-in. Allen wrench
5/64-in. Allen wrench
3/16-in. Allen wrench
Rubber mallet
Belt tensioner gauge
External Retainer Ring Pliers (13/32-1-in. with 0.51-in. tip diameter)

Remove the front shroud:

1. Using Phillips head screwdriver, remove the eight Phillips head screws from the rear shroud.
2. Lift the rear shroud off the unit.

NOTE: Remove ONLY ONE skate rail at a time.

Remove the skate rails from the crank arms:

1. Using 5/32-in. Allen wrench, remove the two Allen screws from the crank arm.
2. CAREFULLY slide the crank arm shaft and two nylon washers out of the skate rail. BE CAREFUL not to lose the two nylon washers.

Remove the crank assembly:

1. Using 9/16-in. open-end wrench, loosen the transmission idler tension nut and bolt so the crank belt is completely loose.
2. Using 3/16-in. Allen wrench, loosen the two crank arm Allen screws. GENTLY slide the two crank arms and keys off of the crank shaft. BE CAREFUL not to lose the crank arm keys. See Diagram A1.

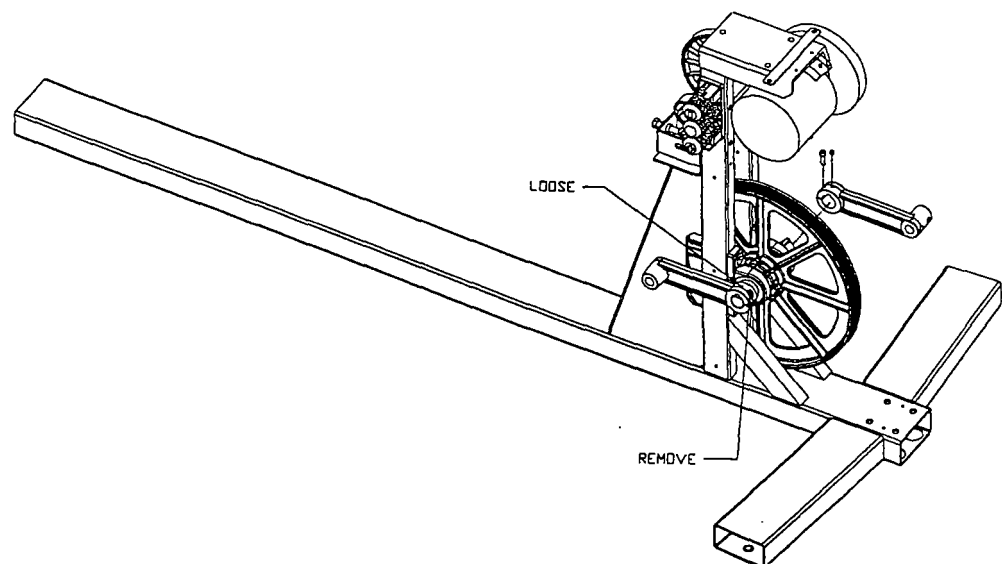

Crank Bearings Replacement

- Loosen the crank belt from the crank pulley. Using 9/16-in. hex head socket wrench and 9/16-in. open-end wrench, remove the four bolts, washers and nuts securing the crank assembly to the frame. CAREFULLY remove the crank assembly from the frame. See Diagram 81.

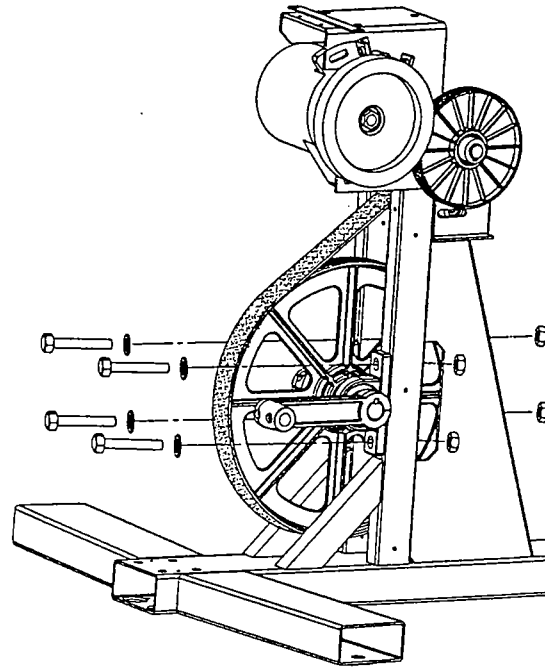

NOTE: If necessary, GENTLY tap the crank pulley to aid in removing the crank pulley from the crank shaft.

NOTE: If necessary, GENTLY tap the crank pulley keys into place with a rubber mallet.

Disassemble the crank assembly:

- Using 5/64-in. Allen wrench, loosen the Allen screws on the two pillow blocks. GENTLY slide the two pillow blocks off of the crank shaft.
- Using external retainer ring pliers, remove the two retainer rings from the grooves on the crank shaft.
- CAREFULLY remove the crank pulley and the two crank pulley keys from the crank shaft. BE CAREFUL not to lose the two crank pulley keys.

Assemble the crank assembly:

- Install the crank pulley on the crank shaft, aligning the two keyways in the crank pulley with the keyways in the crank shaft.
- GENTLY insert the two crank pulley keys into the crank shaft key slots. DO NOT force the keys into place.
- Using external retainer ring pliers, install the two retainer rings in the grooves on the crank shaft (on either side of the crank pulley).
- Install the two pillow blocks on the crank shaft with the Allen screws facing outward (toward the ends of the crank shaft). MAKE SURE the Allen screws in the pillow blocks align with the flats on the crank shaft.

NOTE: MAKE SURE the crank belt is properly positioned before tightening the crank pulley screws.

5. Using 5/64-in. Allen wrench, tighten the pillow block Allen screws just until snug against the crank shaft. **DO NOT OVERTIGHTEN THE SCREWS.**

Install the crank assembly:

1. Insert the crank assembly through the crank belt and position the crank assembly in place on the frame.
2. Using 9/16-in. hex head socket wrench and 9/16-in. open-end wrench, secure the crank assembly to the frame with the four bolts, washers and nuts. **TIGHTEN THE NUTS SECURELY.**
3. **GENTLY** slide the two crank arms onto the crank shaft, aligning the key slots in the crank arm with the key slots in the crank shaft. Insert the two crank arm keys into the crank shaft key slots.
4. Using a straight edge ruler, line up the crank belt with the transmission idler pulley by adjusting the position of the crank pulley on the crank shaft as needed.
5. Using 7/64-in. Allen wrench, tighten the two crank pulley Allen screws to 80 in.-lbs.
6. Using 5/64-in. Allen wrench, tighten the two pillow block Allen screws to 34 in.-lbs.
7. Using 3/16-in. Allen wrench, tighten the two crank arm Allen screws (securing the crank arms to the crank shaft) to 80 in.-lbs.

Re-tention the transmission pulley:

1. Using 9/16-in. open-end wrench, tighten the transmission idler tension bolt to increase crank belt tension.
2. Using belt tensioner gauge to check crank belt tension, continue to tighten the transmission idler tension bolt to achieve 80 pounds tension.
 - If a belt tensioner gauge is not available, check the crank belt tension by pressing down hard on top of the belt, midway between the transmission idler pulley and the crank pulley. The belt should deflect between 3/8-in.-1/2-in. (9.5-12.5 mm).
3. Once the correct crank belt tension is obtained, tighten the transmission idler tension nut **SECURELY** using 9/16-in. open-end wrench.

NOTE: Install ONLY ONE skate rail at a time.

Install the skate rails on the crank arms:

1. Install one nylon washer on the crank arm shaft. **CAREFULLY** insert the crank arm shaft through the skate rail, then install the remaining nylon washer on the crank arm shaft.
2. Insert the crank arm shaft through the crank arm.
3. Rotate the crank arm shaft, as needed, until the flats on the shaft are aligned with the holes in the crank arm.
4. Using 5/32-in. Allen wrench, install the two Allen screws in the crank arm. **TIGHTEN THE SCREWS SECURELY.**

NOTE: MAKE SURE the crank belt is properly positioned before tightening the crank pulley screws.

5. Using 5/64-in. Allen wrench, tighten the pillow block Allen screws just until snug against the crank shaft. **DO NOT OVERTIGHTEN THE SCREWS.**

Install the crank assembly:

1. Insert the crank assembly through the crank belt and position the crank assembly in place on the frame.
2. Using 9/16-in. hex head socket wrench and 9/16-in. open-end wrench, secure the crank assembly to the frame with the four bolts, washers and nuts. **TIGHTEN THE NUTS SECURELY.**
3. **GENTLY** slide the two crank arms onto the crank shaft, aligning the key slots in the crank arm with the key slots in the crank shaft. Insert the two crank arm keys into the crank shaft key slots.
4. Using a straight edge ruler, line up the crank belt with the transmission idler pulley by adjusting the position of the crank pulley on the crank shaft as needed.
5. Using 7/64-in. Allen wrench, tighten the two crank pulley Allen screws to 80 in.-lbs.
6. Using 5/64-in. Allen wrench, tighten the two pillow block Allen screws to 34 in.-lbs.
7. Using 3/16-in. Allen wrench, tighten the two crank arm Allen screws (securing the crank arms to the crank shaft) to 80 in.-lbs.

Re-tention the transmission pulley:

1. Using 9/16-in. open-end wrench, tighten the transmission idler tension bolt to increase crank belt tension.
2. Using belt tensioner gauge to check crank belt tension, continue to tighten the transmission idler tension bolt to achieve 80 pounds tension.
 - If a belt tensioner gauge is not available, check the crank belt tension by pressing down hard on top of the belt, midway between the transmission idler pulley and the crank pulley. The belt should deflect between 3/8-in.-1/2-in. (9.5-12.5 mm).
3. Once the correct crank belt tension is obtained, tighten the transmission idler tension nut **SECURELY** using 9/16-in. open-end wrench.

NOTE: Install ONLY ONE skate rail at a time.

Install the skate rails on the crank arms:

1. Install one nylon washer on the crank arm shaft. **CAREFULLY** insert the crank arm shaft through the skate rail, then install the remaining nylon washer on the crank arm shaft.
2. Insert the crank arm shaft through the crank arm.
3. Rotate the crank arm shaft, as needed, until the flats on the shaft are aligned with the holes in the crank arm.
4. Using 5/32-in. Allen wrench, install the two Allen screws in the crank arm. **TIGHTEN THE SCREWS SECURELY.**

STAR BY UH:SEN.INC.

TRAC ET FRAME ASSY.

Item No	Part Number	Description	Qty Per	Core
1	721-0023-2	Frame, Painted,et,s-grey	1	N
2	721-0002	Assy, Crank,et	1	N
3	721-0006	Assy, Roller,rear,et	4	N
4	721-0016	Assy, Rail,et	2	N
5	721-0003	Assy, Transmission,et	1	N
6	020-6051	Shaft, Pulley,tension	2	N
7	721-0030	Assy, Pulley/roller,tension	2	N
8	020-6049	Spacer, 1 Id X 1.5 Od X 1.61	2	N
9	020-6048	Spacer, 1 Id X 1.5 Od X 2.2 L	2	N
10	020-6050	Shaft, Belt,capture	2	N
11	721-0019	Assy; Alternator'	1	N
12	130-1652	Belt, Alternator,et	1	N
13	110-3099	Bolt, 1/4-20x1.25,hhcs All Thd	1	N
14	020-6055	Bracket, Adjustment,alt	1	N
15	020-6019	Shaft, Crank Arm,et	2	N
16	110-3100	Bolt, 3/8-16 X 3.5 Hhcs	5	N
17	120-0463	Washer 3/8 Flat	10	N
18	110-1830	Nut Hex 3/8 - 16 Nylon	5	N
19	110-3102	Bolt, 5/16-18 X 2.75 Hhcs	4	N
20	110-1871	Nut 5/16 -18	6	N
21	120-0480	Washer 5/16-18 Flat Cut x 7/8 00	16	N
22	110-3080	Screw, 5/16-18 X 1.50", Hhts	4	N
23	120-0495	Washer 5/16 Lock	4	N
24	140-0039	Fool Adjustable Leveler	4	N
25	110-1823	Nul Hex 1/2-13 X 5/16 LOCK NUT FOR ADJ.	4	N
26	020-6057	Guide, Shuttle Belt	2	N
27	130-1650	Idler, EI	1	N
28	020-6004	Adjustment, Idler Slide,et	1	N
29	110-3101	Bolt, 3/8-16 X 2.0hhcs,all Thd	1	N
30	110-1831	Nut 3/8 - 16 Kept	1	N
31	020-6064-01	Shuttle, Casted,left,et	1	N
32	020-6064-02	Shuttle, Casted,right,et	1	N
33	020-6065-01	Pad, Foot,left,et	1	N
34	020-6065-02	Pad, Foot,right,et	1	N
35	110-3097	Screw, 1/4-20 X 2.751, Shes	8	N
36	110-3098	Nut, 1/4-20 Nyloc	8	N
37	120-0410	Washer Flat 1/4"	8	N
38	120-0470	Washer 3/8" Lock	4	N
39	110-3096	Nut, 7/16-20,lock	4	N
40	140-3143	Hairpin, 3/8 To 1/2	4	N
41	020-6075	Wheel, 2.000 X .53id	2	N
42	120-3018	Spacer, 5/16id X 5/8ed X .3321	4	N
43	110-1515	Bolt,5/16-18 X 1.75"	2	N
44	130-1647	Roller, .312id X 1.10 Od X .80	2	N
45	110-1415	Axle Push Caps 1/2"	2	N
46	110-0477	Screw 1/4-20 X .75shcs	4	N
47	110-2180	Bolt 5/16 -18 X 1.0"	1	N
48	110-3103	Bolt, 1/2-13 X 2.0 Hhes	1	N
49	120-0630	WASHER FLAT 1/2" X 10 X7/8" 0.0..033	1	N
50	110-1824	Nut Heavy Hex 1/2 -13	1	N
51	120-2540	Washer Lock 3/8	1	N
52	120-3014	Spacer, Crank,et	4	N
53	110-3109	Screw, 10-24x.5,shes	8	N
54	120-0350	Lock Washer #10 Split	8	N
55	130-1666	Belt, Orive,et	1	N
56	140-3141	End Cap, 2 X 4	2	N

ET FRAME ASSY

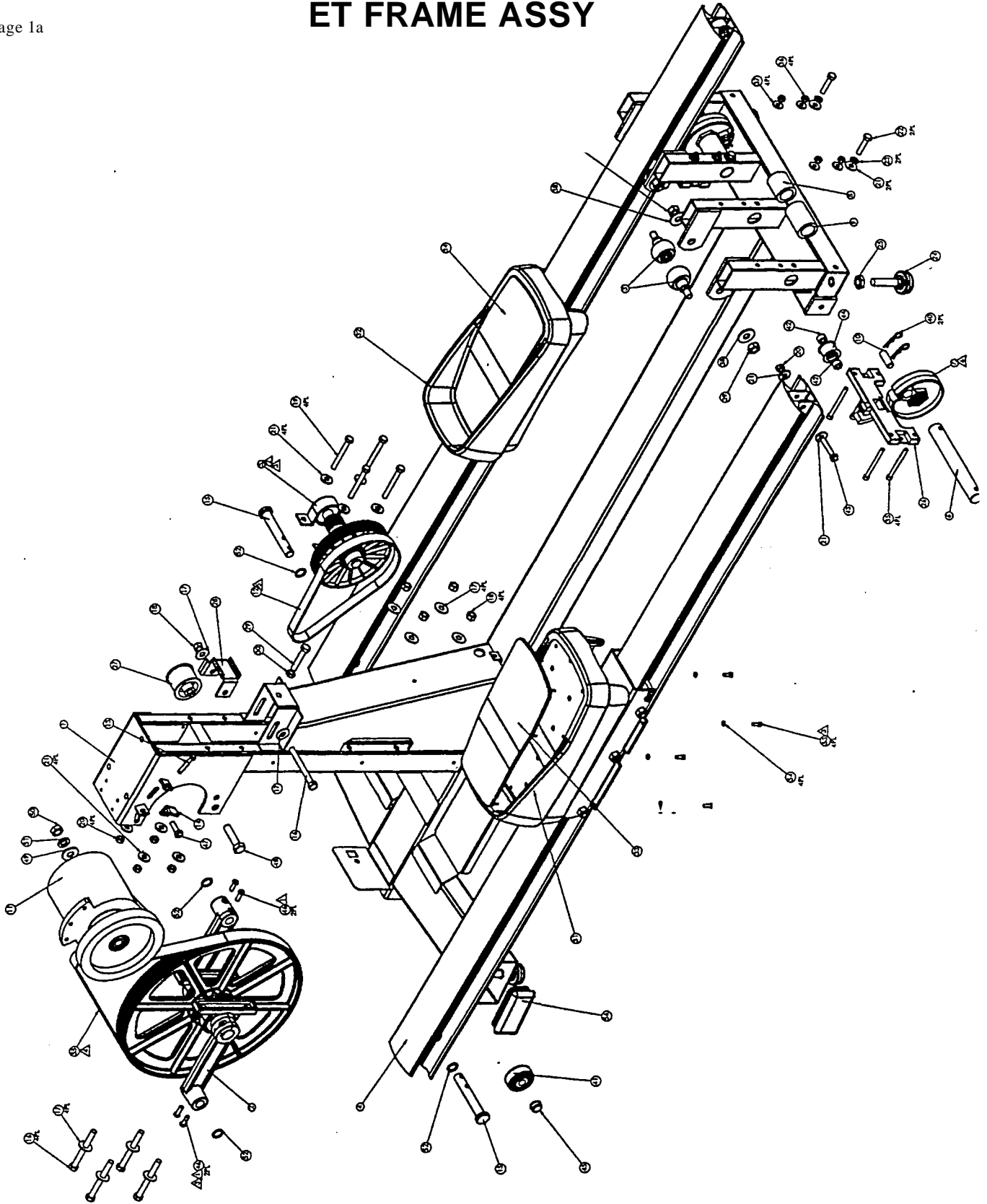

ET 4600

Page: 2

STAR BY UN/SEN. **INC.**
TRAC - **ELECT. KIT, ET**

Item No	Part Number	Description	Qty Per	Core
1	721-0023-2	Frame, Painted,et,s-grey	1	Y
2	721-0022	Assy, Mcb	1	Y
3	721-0012	Assy, Cable Mcb/res,et	1	N
4	020-6054	Brace, Bracket,mcB,et	1	N
5	110-3026	Screw 10 - 24 X .75"	8	N
6	240-6846	Conn, 8 Pos, In-line -	1	N
7	721-0013	Assy, Battery/therm,et	1	N
8	721-0032	Assy, Batltherm	1	N
9	220-0155	Cable, Ext Power/mcb	1	N
10	721-0034	Assy, Cable,fitlinx,et	1	N
11	140-0058	Tape, Shielding,die Cut,1.0 Od	1	N
12	140-0057	Tie Mount, 3/4,w/acrylic Adhes	6	N
13	140-0210	Tie Strap, 3.5"	10	N
14	140-0200	Tie Strap 5"	1	N
15	140-3128	Tie Strap, 8.0"	1	N
16	721-0019	Assy, Alternator	1	N
17	050-1739	Label, Id,et	1	N

ELECTRICAL KIT ET

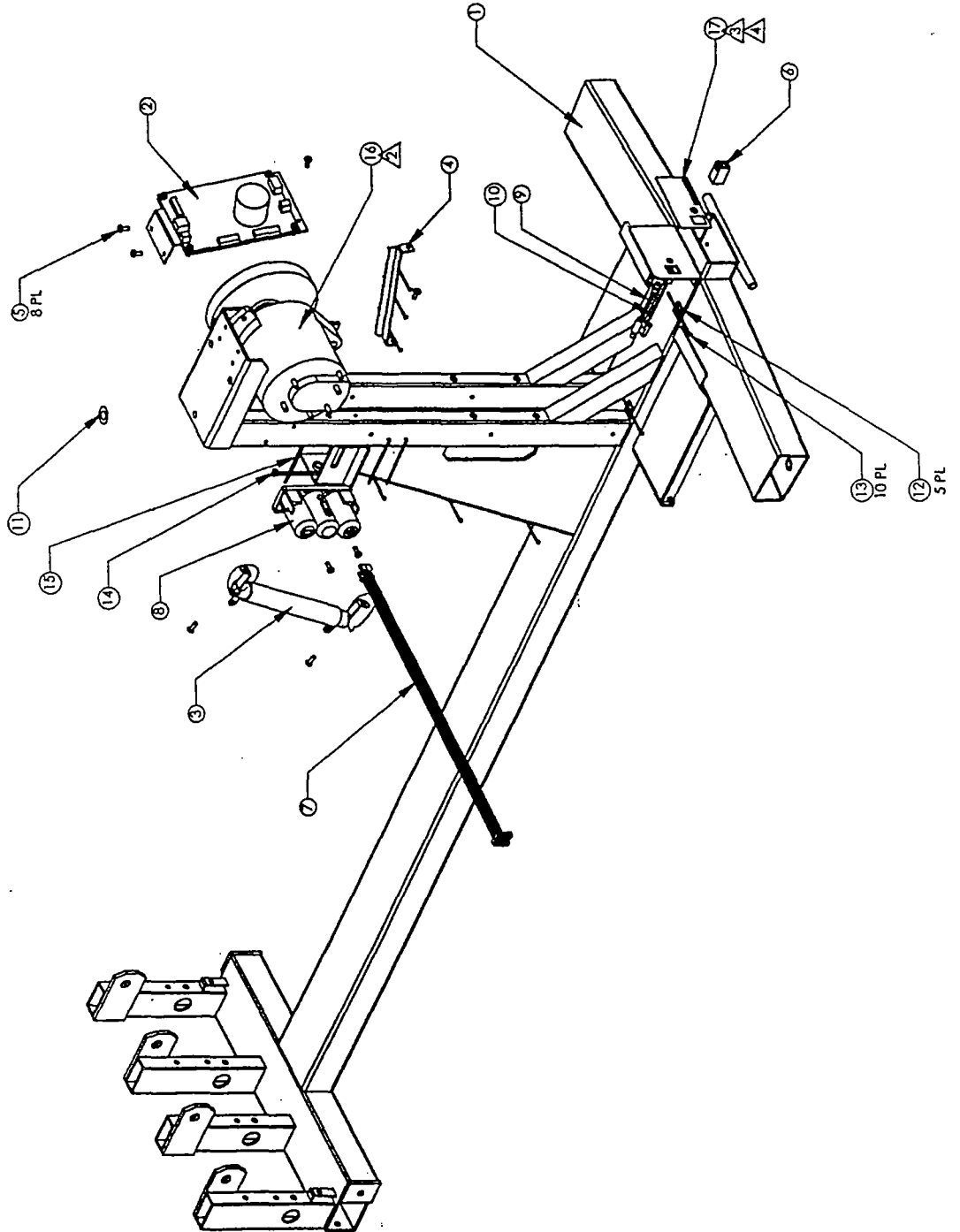
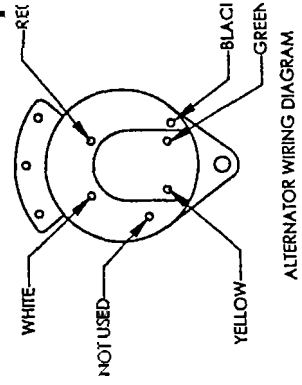



ET 4600

SHROUD KIT, ET

Item No	Part Number	Description	Qty Per	Core
1	721-0023-2	Frame, Painted,et,s-grey	1	N
2	020-6026	Shroud, Rear,et	1	N
3	020-6027	Shroud, Cheeks,et	1	N
4	020-6024	Shroud, Front-a,et	1	N
5	020-6023	Shroud, Collar,et	1	N
6	020-6025	Shroud, Front-b,et	1	N
7	020-6071	Handelbar, Rear Shroud,et	1	N
8	N/A			
9	140-3132	Fastener, U-type, #10-24	9	N
10	110-3106	Screws, 10-24 X 1.5 Pphms	8	N
11	110-3108	Screw, 5/16-18 X 1.00 Pphms	4	N
12	110-3107	Screw, 10-24 X 7/8 Rolok, Pphs	5	N
13	050-1737	Logo, Eliptical Edge	1	N
14	050-1738	Label, Shroud, Ee	2	N
15	020-6062	Bracket, Shroud,upper,et	1	N
16	110-3026	Screw 10 - 24 X .75"	2	N

SHROUD KIT ET

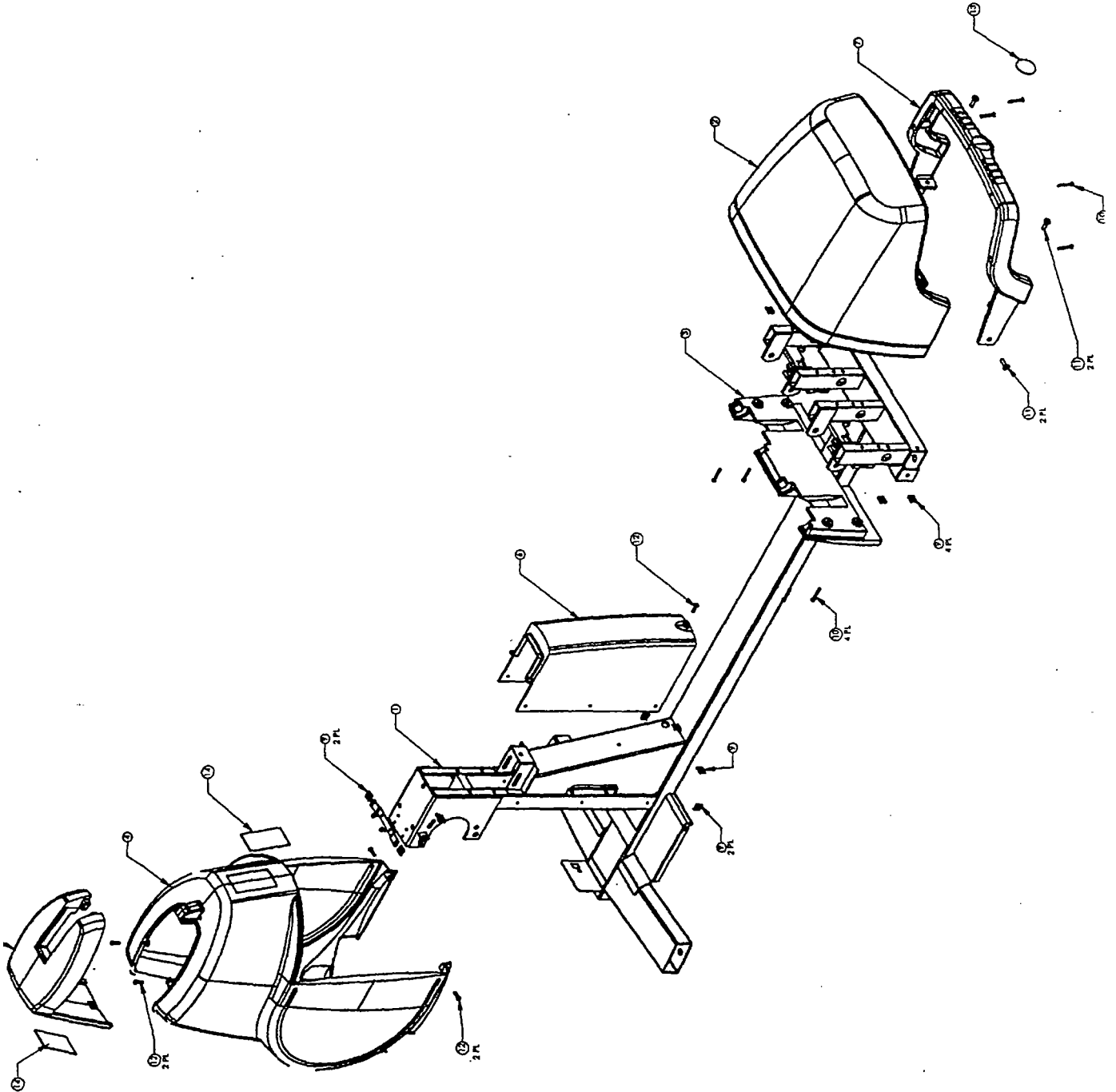



ET 4600

Page: 4

CRANK ASSY. ET

Item No	Part Number	Description	Qty Per	Core
1	020-4620	Shaft, Crank Pulley,et	1	N
2	020-6002	Crank Arm, Et	2	N
3	130-1671	Pillow Block, 1.0" id	2	N
4	140-3144	Key, 0.25 "sq X 1.25"	1	N
5	140-3145	Key, 0.25" Sq X 0.75"	2	N
6	140-3147	Snap Ring, .925 id	2	N
7	110-3104	Bolt, 1/4-20 X .75 Shes	2	N
8	110-3093	Screw, 1/4-20x.25,set,self Loc	2	N
9	020-6001	Pulley, Crank,cast	1	N
10	110-3110	Screw, 1/4-28 X .25,set,patch	2	N
99	721-0002	Assy, Crank,et	1	N

CRANK ASSY ET

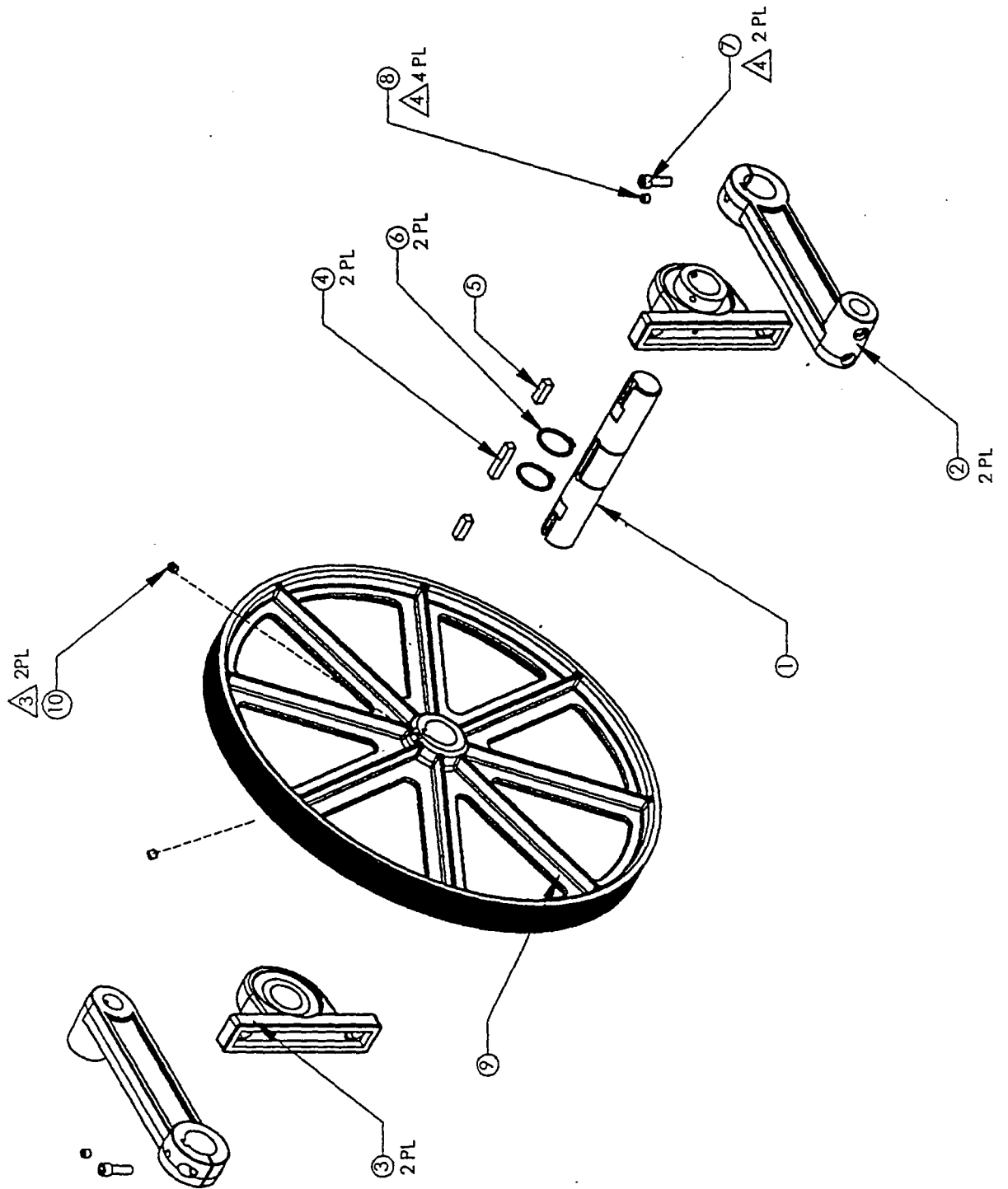



ET 4600

Page: 5

TRANSMISSION ASSY. ET

Item No	Part Number	Description	Qty Per	Core
1	020-4621	Shaft, Transmission,et	1	N
2	130-1651	Pillow Block, 3/4"	2	N
3	140-3146	Key, 3/16 X 1/4 X 1.20	2	N
4	130-1639	Pulley, 8j,6.0 Od X .75 Id	1	N
5	130-1640	Pulley, 10j,1.230d X'.75id	1	N
6	110-3093	Screw, 1/4-20x.25,set,selt Loc	1	N
7	110-3105	Screw, 10-32x.25,set,patch	2	N
99	721-0003	Assy, Transmission,et	1	N

Transmission Assy. ET

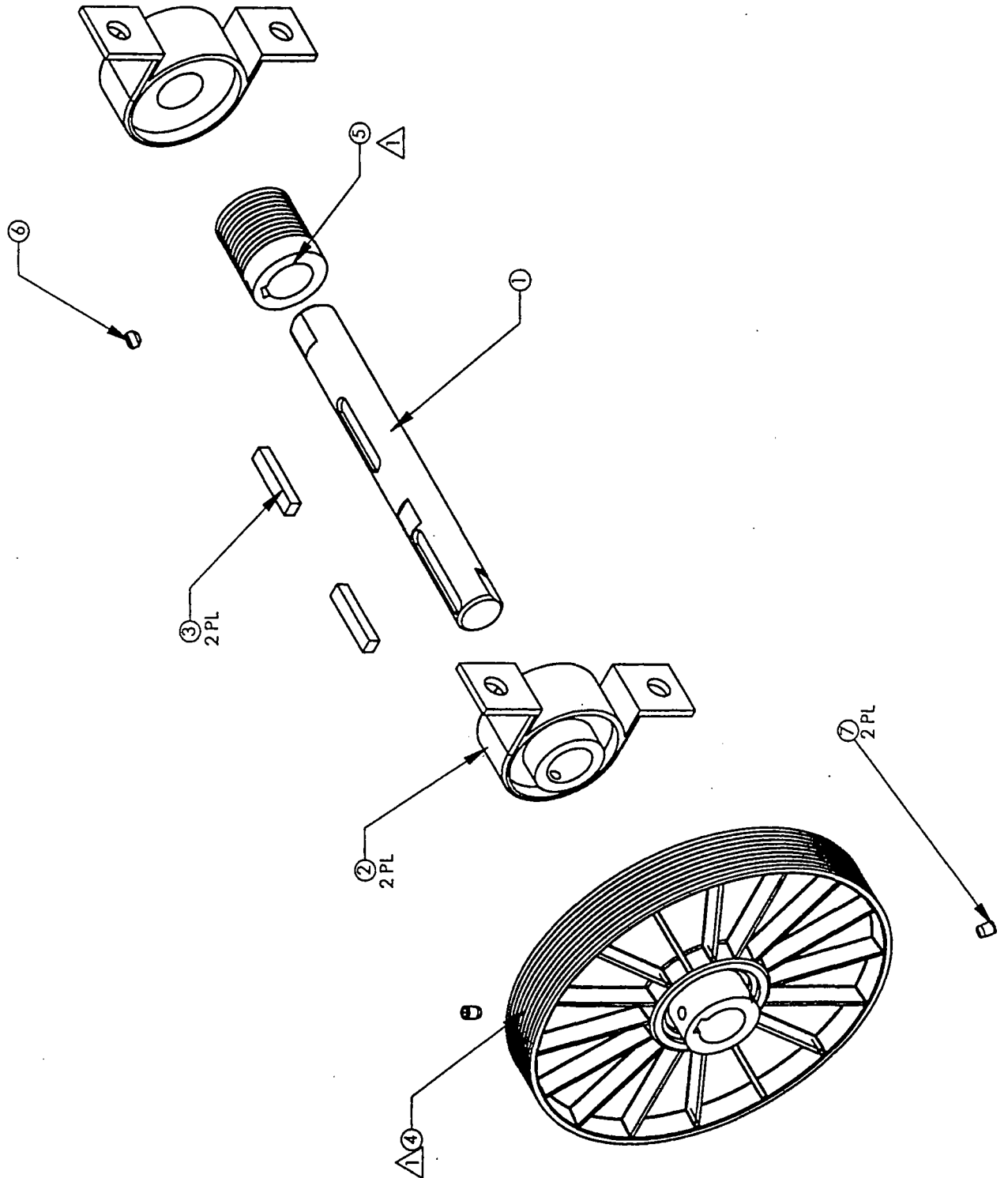



DISPLAY KIT ET

Item No	Part Number	Description	Qty Per	Core
1	020-6021-2	Housing, Display,greY,et	1	N
2	020-6022-2	Housing, Display,rear,greY,et	1	N
3	050-1733	Keypad, Left,eUcv	1	N
4	050-1734	Keypad, Center,eUcv	1	N
5	050-1735	Keypad, Right,eUcv	1	N
6	715-3320-01	Pcba, Display,upper,eUcv	1	N
7	715-3320-02	Pcba, Display,lower,eUcv	1	N
8	110-0020	Screw,4-40x1/4 Phil Pan	5	N
9	110-0250	Screw, 6-32 X 1/2" Rhms	3	N
10	120-3002	Washer #6	5	N
11	120-3021	Standoff, 8-32 X 1.125,m-f	7	N
12	721-0027	Cable, Disp. Brd, Connector,et	1	N
13	140-0665	Double Sided Tape	.1	N
14	711-1030	Polar Reciever	1	N
99	7-4600-MUSf	Kit, Display,eUcv,usa,met Gry	1	Y
99	7-4620-GUSf	Kit, Disp,pol,eUcv,usa,greY	1	Y
99	7-4620-MUS,	Assy, Display,greY,et	1	Y
99	7-4630-MUS;	Kit, Disp,c/p Hr,eUcv,usa,gry	1	Y

EE DISPLAY KIT

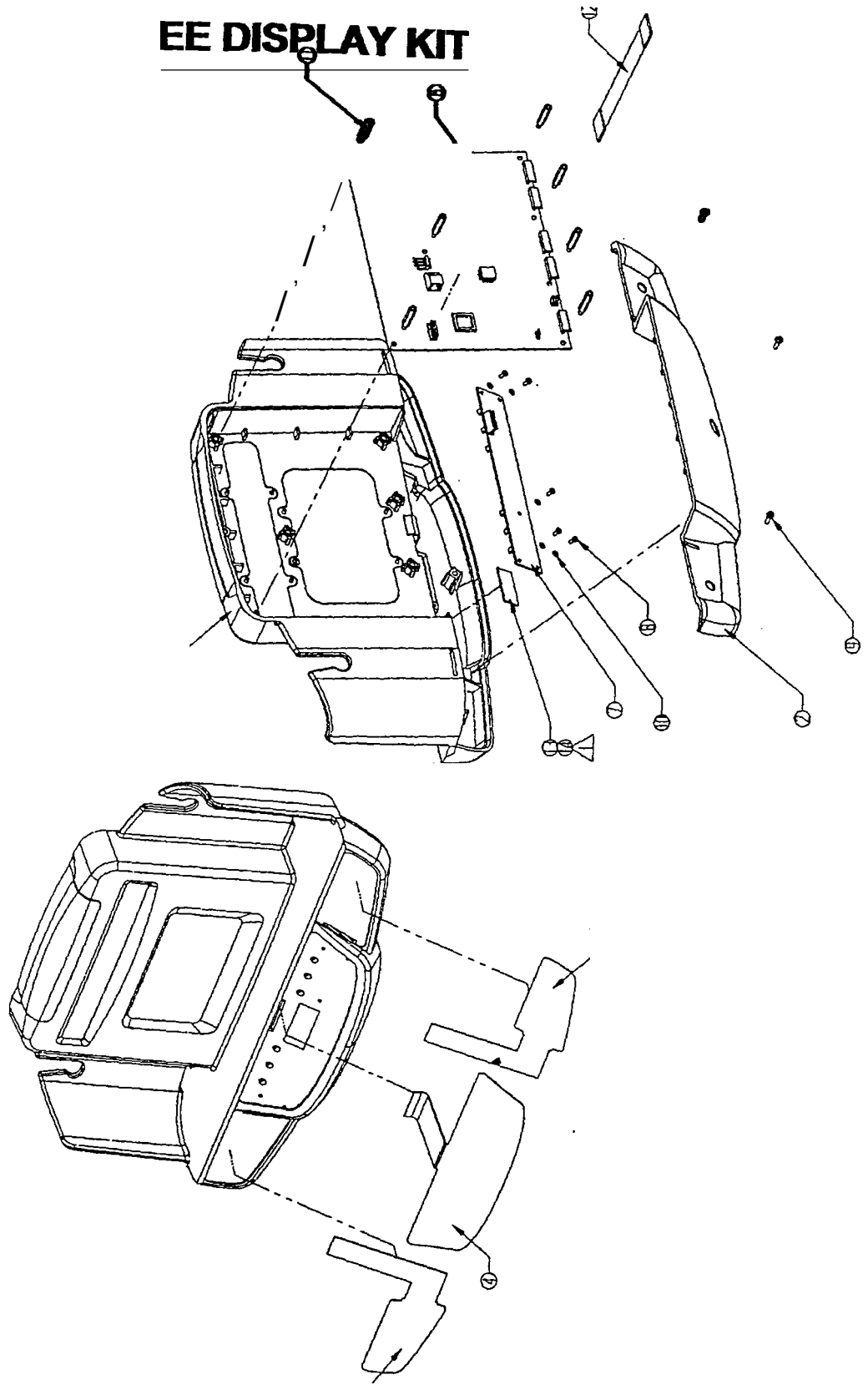



NECK / HANDRAIL KIT, ET

Item No	Part Number	Description	Qty Per	Core
1	721-0018-01	Assy, Rail,lt,et	1	N
2	721-0018-02	Assy, Rail,rt,et	1	N
3	721-0024-2	Neck, Painted,et,s-grey	1	N
4	020-6074	Plate, Cover,back,disp,s-grey	1	N
5	020-5035	Bracket, Handrail,attach,et	2	N
6	110-3090	Screw, 8-32 Hbhcs	8	N
7	110-3091	Screw, 1/3-20x2.25,shcs	4	N
8	110-3092	Screw, 5/16-18x.875, Bhscs	8	N
9	140-0054	Gasket, Emi, W/adhesive Back	.0	N
10	721-0010	Assy, Cable Display,power,et	1	N
11	721-0011	Assy, Cable Display,signal,et	1	N
12	721-0033	Assy, Conn,fitlinxlcadio,et	1	N
13	140-0058	Tape, Shielding,die Cut,1.0 Od	1	N
14	020-6063	Grommet, Neck,et	1	N

RAIL ASSEMBLY KIT

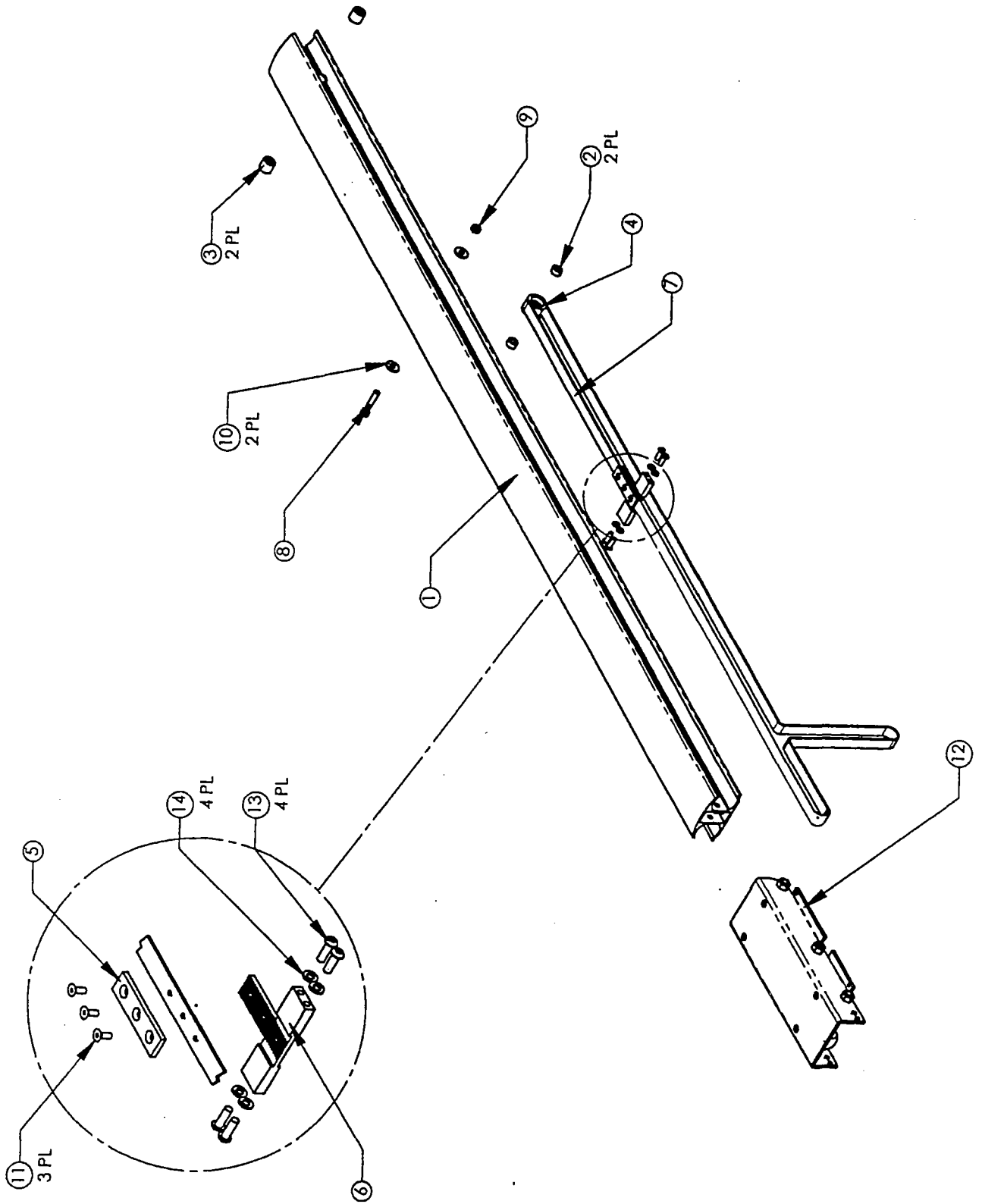



RAIL ASSY. ET

Item No	Part Number	Description	Qty Per	Core
1	721-0015	Weldment, Rail,et	1	N
2	120-3018	Spacer, 5/16id X 5/80d X .3321	2	N
3	130-1667	Bearing, Roller,5/8id X 13/16	2	N
4	130-1647	Roller, .312id X 1.10 Od X .80	1	N
5	020-6041	Plate; Capture,belt,et	1	N
6	020-6040	Plate, Connecting,belt,et	1	N
7	130-1648	Belt, Shuttle Rail,et	1	N
8	110-1515	Bolt,5/16-18 X 1.75"	1	N
9	110-1871	Nut 5/16 - 18	1	N
10	120-0480	Washer 5/16-18 Flat Cut x 7/8 00	2	N
11	110-3094	Screw, #10-32 X 1/2,fhss	3	N
12	721-0005	Assy, Shuttle,et	1	N
13	110-0477	Screw 1/4-20 X .75shcs	4	N
14	120-0420	Washer Lock 1/4" Split	4	N
99	721-0016	Assy, Rail,et	2	N

HANDRAIL KIT ET

